

HYDRAULIC ACCESSORIES



SELECT FROM A WIDE RANGE OF HYDRAULIC ACCESSORIES TO COMPLETE YOUR SYSTEM REQUIREMENTS

- Power Team offers the widest selection of pump-mounted, remote or in-line valves to control your hydraulic circuit requirements.
- A wide variety of hose types, sizes and configured arrangements in rubber or polyurethane
- High pressure fittings, gauges, and other miscellaneous accessories to fit your needs





	Section	Page Content	Pages
	Introduction	Choosing the Right Valve and Circuit Schematics	113-114
	Valves	Valve Selection / Pump Options Pump-Mounted Hydraulic Pump Accessories Remote-Mounted In-Line	115-116 117-124 125-126 127-128 129-131
	Fluids	Standard Hydraulic Oil, Flame Out [®] , Bio Degradable, Low Temperature	132
	Pump Accessories	Motor Controls, Sub-plates, Air Filter / Regulator / Lubricator, Pressure Switch, Air Control Valves, Oil Cooler Kits, Reservoir Breather Kits, Casters, Fluid Level / Temp. Gauge, Foot Control Guard, Magnetic Strip, Seal Kits, Carts / Roll Cages, Reservoirs	133-134
	Hoses	Rubber, Wire-Braid Polyurethane Non-Conductive	135-137
	Couplers	Quick-Connect, Flush Face	138
	Gauges	Heavy-Duty Hydraulic Digital and Analog	139-142
	Manifolds	Standard Blocks Blocks with Valves	143
	Fittings	Connectors, Couplings, Crosses, Elbows, Tees, Swivels, Special Adapters	144



SELECTING THE RIGHT VALVE:

Step 1: What is the tool requirement for valve control - single or double-acting?

Step 2: Determine how you intend to plumb the valve in hydraulic circuit - mounted or remote?

Step 3: How will you operate it - manual or remote? What type of directional control is needed?

VALVE SIZING CONSIDERATIONS:

- Will the valve be used with single or double-acting cylinders?
- Will the valve be mounted on the pump, away from the pump or directly into the hydraulic lines?
- Will the valve be manually-operated or is remote control preferred?
- Is independent control of multiple cylinders, or hydraulic tools preferred?
- What directional control and pressure control valve functions are needed for the application?
- Note: Basic valve types include manually-operated, air or solenoid-operated and pilot-operated. Special application valves for pre-stressing and post-tensioning are also offered. Consult valve selection chart on pages 115-116 for listings of all Power Team valves.

DIRECTIONAL CONTROL VALVES

2-WAY, 2-POSITION

(FOR CONTROL OF SINGLE-ACTING CYLINDERS)

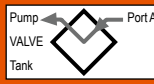
POSITION 1	CENTER POSITION	POSITION 2
 <p>Oil goes from pump to cylinder. Pressure is held from valve to cylinder when pump is shut-off.</p>	None	 <p>Oil goes from cylinder to pump. Pressure is released to reservoir when motor is turned off.</p>



3-WAY, 2-POSITION

(FOR CONTROL OF SINGLE-ACTING CYLINDERS)

POSITION 1	CENTER POSITION	POSITION 2
 <p>Oil goes from pump to cylinder and holds when pump is shut-off. Return line to reservoir is blocked.</p>	None	 <p>Cylinder retracts, oil returns to reservoir.</p>

3-WAY, 3-POSITION

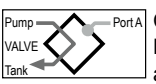
(FOR CONTROL OF SINGLE-ACTING CYLINDERS)

POSITION 1	CENTER POSITION	POSITION 2
 <p>Oil goes from pump to cylinder and holds when pump is shut-off. Return line to reservoir is blocked.</p>	 <p>Cylinder pressure is held. Pump can remain running and oil returns to reservoir.</p>	 <p>All oil is open to reservoir through return line.</p>



IN-LINE HYDRAULIC VALVES

Load-Lowering Valve – Provides precision metering for controlled return of the cylinder piston.

Sequence Valve – Used when a cylinder in a multiple cylinder application must advance before any other.

Pressure Reducing Valve – Permits independent pressure control to two or more, clamping systems operated by a single power source.

Shut-off Valve – For fine metering of hydraulic oil. Several may be used to control multiple single-acting cylinders.

Check Valve – Permits flow of hydraulic oil in one direction only.

Pressure Relief Valve – Used at remote locations in a hydraulic circuit where maximum pressure requirements are less than the setting of the basic overload valve in the pump. Protects a hydraulic system against over pressurization.

Metering Valve – Restricts surges by restricting flow to a certain level. When flow subsides, valve reopens automatically. For systems using large cylinders or extended lengths of hose.



Pressure Regulator Valve – Permits external adjustment of operating pressures at various values below the internal relief valve setting of the pump.

CAUTION: To prevent sudden, uncontrolled descent of a load as it is being lowered, use a 9596 Load-Lowering Valve or 9720 Counter Balance Valve in conjunction with the directional valve used in your application.

DIRECTIONAL CONTROL VALVES

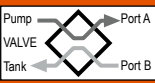

4-WAY, 2-POSITION

(FOR CONTROL OF SINGLE-ACTING CYLINDERS)

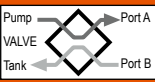

POSITION 1	CENTER POSITION	POSITION 2
 <p>Oil goes to the "extend" side of the cylinder. The oil from the "retract" side returns to reservoir. Cylinder holds with pump shut-off.</p>	None	 <p>Oil goes to the "retract" side of the cylinder, oil from the "extend" side returns to reservoir.</p>

4-WAY, 3-POSITION

(FOR CONTROL OF DOUBLE-ACTING CYLINDERS)

POSITION 1	CENTER POSITION	POSITION 2
 <p>Oil goes to the "extend" side of the cylinder, oil from the "retract" side returns to reservoir. Cylinder holds with pump shut-off.</p>	 <p>Holds pressure even if pump is running. Oil from pump goes through valve, back to reservoir.</p>	 <p>Oil goes to "retract" side of cylinder. Oil from "extend" side returns to the reservoir.</p>

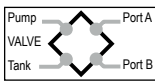
TYPICAL CENTERS

TANDEM CENTER	CLOSED POSITION	OPEN CENTER
 <p>Cylinder ports are blocked, oil from pump goes to reservoir. Used when pump remains running. Example: gasoline-driven pumps.</p>	 <p>Generally used when running multiple valves in series from one pump.</p>	 <p>Open Center used when holding is not a requirement, as when running two separate hydraulic tools such as cutters / crimpers.</p>

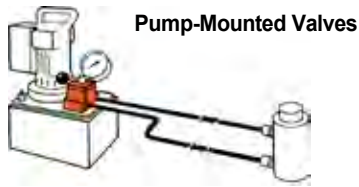

Order No.	Page No.	Cylinder* Applications	Operation	Valve Type	Volt	Advance / Return	Advance / Hold Return	**Posi-Check® Feature
9500	120	SA / DA	Manual	4-Way, 3-Pos. Tandem Center	—	No	Yes	No
9501	120	SA / DA	Manual	4-Way, 3-Pos. Closed Center	—	No	Yes	Yes
9502	119	SA	Manual	3-Way, 3-Pos. Closed Center	—	No	Yes	Yes
9504	118	SA / DA	Manual	3/4-Way, 2-Pos.	—	Yes	Yes	No
9506	120	DA	Manual	4-Way, 3-Pos. Tandem Center	—	No	Yes	Yes
9507	120	DA	Manual	4-Way, 3-Pos. Closed Center	—	No	Yes	Yes
9511	120	SA / DA	Manual	4-Way, 3-Pos. Open Center	—	Yes	Yes	No
9512	123	DA	Solenoid	4-Way, 3-Pos. Tandem Center	24	No	Yes	Yes
9513	123	DA	Solenoid	4-Way, 3-Pos. Tandem Center	115	No	Yes	Yes
9516	123	DA	Solenoid	4-Way, 3-Pos. Tandem Center	12	No	Yes	Yes
9517	118	SA	Manual	2-Way, 2-Pos.	—	No	Yes	No
9519	123	DA	Solenoid	4-Way, 3-Pos. Tandem Center	230	No	Yes	Yes
9520	119	SA	Manual	4-Way, 3-Pos. Tandem Center	—	No	Yes	Yes
9522	123	DA	Solenoid	4-Way, 3-Pos. Open Center	230	Yes	No	No
9523	123	SA	Pilot-Operated Solenoid	3-Way, 2-Pos.	230	Yes	No	No
9552	122	SA / DA	Solenoid	3/4-Way, 2-Pos.	230	Yes	No	No
9553	123	SA	Pilot-Operated Solenoid	3-Way, 2-Pos.	24	Yes	No	No
9569	122	SA	Solenoid	3-Way, 2-Pos.	24	No	Yes	No
9570	122	S.A.	Solenoid	3-Way, 2-Pos.	230	No	Yes	No
9572	122	SA / DA	Solenoid	3/4-Way, 2-Pos.	24	Yes	No	No
9579	122	SA	Solenoid	3-Way, 2-Pos.	115	No	Yes	No
9582	117	SA	Manual	3-Way, 2-Pos.	—	No	Yes	No
9584	117	SA	Manual	3-Way, 2-Pos.	—	No	Yes	No
9589	123	SA	Pilot-Operated Solenoid	3-Way, 2-Pos.	115	Yes	No	No
9590	123	DA	Solenoid	4-Way, 3-Pos. Open Center	115	Yes	No	No
9592	122	SA / DA	Solenoid	3/4-Way, 2-Pos.	115	Yes	No	No
9594	122	SA / DA	Air	3/4-Way, 2-Pos.	—	No	Yes	Yes
9599	121	SA	Pilot-Operated Solenoid	3-Way, 3-Pos. Tandem Center	24	No	Yes	Yes
9605	121	SA	Pilot-Operated Solenoid	3-Way, 3-Pos. Tandem Center	115	No	Yes	Yes
9609	121	SA	Manual	3-Way, 3-Pos. Tandem Center	—	No	Yes	No
9610	117	SA	Auto Pilot-Operated	3-Way, 2-Pos.	—	Yes	No	No
9610A	117	SA	Manual	2/3-Way, 2-Pos.	—	No	Yes	No
9615	123	DA	Solenoid	4-Way, 3 Pos. Open Center	24	Yes	No	No
9628	124	SA / DA	Manual	Post-Tensioning	—	Special	No	No
9632	124	SA / DA	Manual	Post-Tensioning	—	Special	No	No

Note:

* "SA" represents single-acting cylinders and "DA" represents double-acting cylinders.

** The Posi-Check® feature guards against pressure loss when shifting from "advance" to "hold" position.

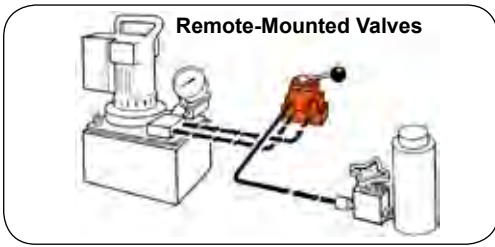

Order No.	Page No.	Cylinder Applications*	Operation	Valve Type	Volt	Advance / Return	Advance / Hold Return	**Posi-Check® Feature
9508	128	SA / DA	Manual	4-Way, 3-Pos. Closed Center	—	No	Yes	Yes
9509	128	SA / DA	Manual	4-Way, 3-Pos. Tandem Center	—	No	Yes	Yes
9514	128	DA	Solenoid	4-Way, 3-Pos. Tandem Center	115	No	Yes	Yes
9524	127	SA / DA	Solenoid	3/4-Way, 2-Pos.	230	No	Yes	No
9525	128	DA	Solenoid	4-Way, 3-Pos. Tandem Center	230	No	Yes	Yes
9526	128	SA	Solenoid	3-Way, 2-Pos.	230	No	Yes	No
9554	127	SA / DA	Solenoid	3/4-Way, 2-Pos.	24	No	Yes	No
9555	128	DA	Solenoid	4-Way, 3-Pos. Tandem Center	24	No	Yes	Yes
9556	128	SA	Solenoid	3-Way, 2-Pos.	24	No	Yes	No
9559	128	SA	Solenoid	3-Way, 2-Pos.	115	No	Yes	No
9593	127	SA / DA	Solenoid	3/4-Way, 2-Pos.	115	No	Yes	No
9595	127	SA / DA	Air	3/4-Way, 2-Pos.	—	No	Yes	No

Note:

* SA™ represents single-acting cylinders and "DA" represents double-acting cylinders.

** The Posi-Check® feature guards against pressure loss when shifting from "advance" to "hold" position.

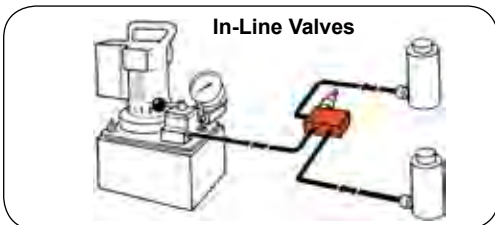

Order No.	Page No.	Cylinder Applications*	Operation	Valve Type
9575	131	SA	Manual	Shut-Off Valve
9580	131	SA	Automatic	One-Way Check Valve
9581	131	SA / DA	Automatic	Pilot-Operated Check Valve
9596	129	SA	Manual	Load-Lowering Valve
9597	129	SA / DA	Automatic	Sequence Valve
9608	129	SA / DA	Automatic	Pressure Reducing Valve
9623	131	SA / DA	Automatic	Pressure Relief Valve
9631	130	SA / DA	Automatic	Metering Valve
9633	130	SA / DA	Automatic	Pressure Regulator Valve
9720	129	SA / DA	Automatic	Counter Balance Valve
9721	129	SA / DA	Automatic	Counter Balance Valve
RV21278	130	—	Automatic	Relief Valve

Note:

* "SA" represents single-acting cylinders and "DA" represents double-acting cylinders.

3-WAY / 2-POSITION MANUAL VALVES

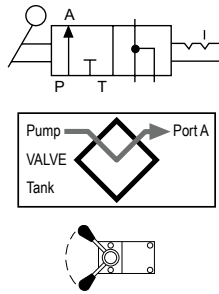
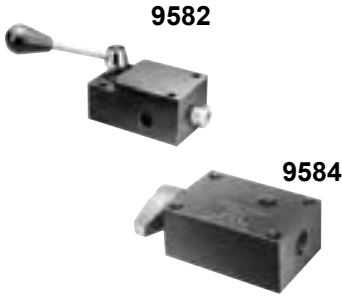

Applications: Single-acting cylinders.

Actuation: Lever-operated.

Functions: Cylinder piston "advance," "hold" and "return."

Used on these pumps: P460, PE17, PE21, PE30, PE46, PE55, and PE120 series.

Order No.	Description
9582	3-Way/2-Position manual valve. Wt., 1,1 kg.
9584	3-Way/2-Position manual valve "flipper" control. Wt.,0,8 kg.

3-WAY / 2-POSITION PILOT-OPERATED AUTOMATIC VALVES

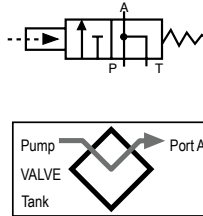

Applications: Single-acting cylinders.

Actuation: Pilot oil.

Functions: When pump is started, pilot oil automatically closes valve and directs oil to cylinder. When pump is stopped, valve automatically opens and oil returns to reservoir.

Used on these pumps: Furnished with pilot lines and adapters for PA55, PA90, PE30, PE55, and PE120 series.

Order No.	Description
9610	3-way/2-position pilot-operated automatic valve. Wt.,1,9 kg.

2/3-WAY/2-POSITION MANUAL/PILOT-OPERATED AUTOMATIC VALVE

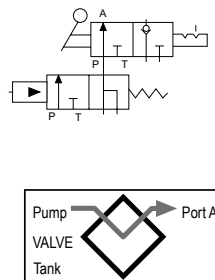

Applications: Manual operation for load lifting and holding with single-acting cylinders; automatic "dump" for operating hydraulic tools.

Actuation: Flipper lever/pilot oil.

Functions: With lever in closed position, valve will hold the load. When lever is "open," valve functions as a true automatic "dump" valve..

Used on these pumps: Furnished with pilot lines and adapters for PA55, PA90, PE30, PE55, and PE120 series. For application on other pumps, consult factory.

Order No.	Description
9610A	2/3-way/2-position manual/pilot-operated automatic valve. Wt., 2 kg.

CAUTION: To prevent sudden, uncontrolled descent of a load as it is being lowered, use a 9596 Load-Lowering Valve or 9720 Counter Balance Valve in conjunction with the directional valve used in your application.

IMPORTANT: Conversion kit 251528 must be used when mounting any of the valves on this page on PA17 or PE17 pumps.

IMPORTANT: When ordering any valve for a PE30 or PG30 series pump, 12,7 mm longer mounting screws are required. For valves 9504, 9584, 9610 and 9610A, order four 12001 cap screws. For valve 9582, order two 12001 and two 10856 cap screws.

2-WAY/2-POSITION MANUAL VALVE

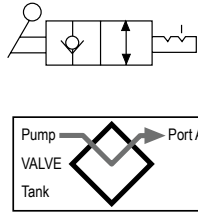

Applications: Single-acting cylinders.
Actuation: Flipper lever-operated.
Functions: Cylinder piston "advance," "hold" and "retract."
Used on these pumps: PE172 and PA172.

Order No.	Description
9517	2-way/2-position manual valve. Wt., 1,5 kg.

3/4-WAY/2-POSITION MANUAL VALVE

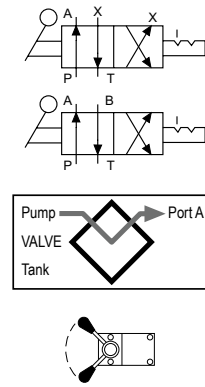
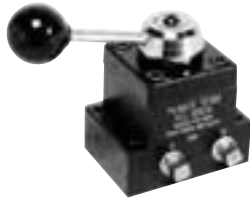

Applications: Single or double-acting cylinders.
Actuation: Lever-operated, detent-positioned.
Functions: Pos. 1 – Oil is directed to "advance" side of cylinder, oil from "retract" side goes to reservoir, cylinder "holds" with pump shut-off. Pos. 2 – Oil goes to "retract" side of cylinder, cylinder "holds" with pump shut-off. When using as a 3-way valve for single-acting cylinders, port "A" or "B" is plugged. See note below regarding plugging of ports and resulting heat build-up..
Used on these pumps: P460, PA6D, PA17, PA46, PA55, PA60, PE17, PE21, PE30, PE46, PE55, PE120, PE400, PQ60 and PQ120 series.

Order No.	Description
9504	3/4-way/2-position manual valve. Wt., 1,9 kg.

NOTE: 9504 can be remote-mounted with a 9510 sub-plate.

CAUTION: To prevent sudden, uncontrolled descent of a load as it is being lowered, use a 9596 Load-Lowering Valve or 9720 Counter Balance Valve in conjunction with the directional valve used in your application.
IMPORTANT: Conversion kit 251528 must be used when mounting any of the valves on this page on PA17 or PE17 pumps.
IMPORTANT: When ordering any valve for a PE30 or PG30 series pump, 12,7 mm longer mounting screws are required. For valves 9504, 9584, 9610 and 9610A, order four 12001 cap screws. For valve 9582, order two 12001 and two 10856 cap screws.
NOTE: Valves 9501, 9502, 9504 and 9507 can have a port blocked or have a closed center position. When a port is blocked and the valve is shifted to the blocked port, the pump will generate excessive heat. An electric or rotary air pump can either be turned off manually or with a pressure switch. Reciprocating air pumps may be adjusted to stall out and stop.

3-WAY/3-POSITION (CLOSED CENTER) NON-INTER FLOW MANUAL VALVE WITH POSI-CHECK®

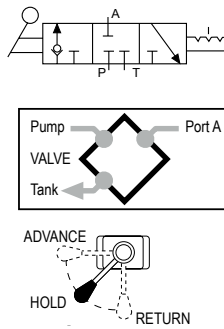
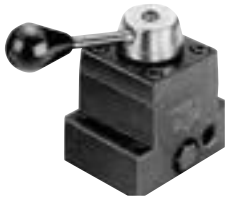

Applications: Single-acting cylinders.

Actuation: Lever-operated, detent-positioned.

Functions: Pos. 1 – Oil is directed from pump to cylinder and “holds” with pump shut-off, line to reservoir is blocked. Pos. 2 – All oil is open to reservoir through tank line. Center Pos. – Cylinder pressure is held, and pump should be shut-off.

Used on these pumps: P460, PA17, PA46, PA55, PA60, PE17, PE21, PE30, PE46, PE55, PE120, PE400, PQ60 and PQ120 series.

Order No.	Description
9502	3-way/3-position (closed center) manual valve. Wt., 1,9 kg.

NOTE: A pressure switch and/or gauge may be attached if desired. Also, the 9502 can be remote-mounted if a 9510 sub-plate is used.

Accessories

3-WAY/3-POSITION (TANDEM CENTER) MANUAL VALVE WITH POSI-CHECK® VALVE

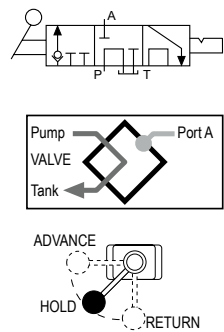

Applications: Single-acting cylinders.

Actuation: Lever-operated, detent-positioned.

Functions: “Advance,” “hold” and “return.” When shifted to “return” position, pump and cylinder return oil through their own separate return lines, allowing faster retraction of piston. The Posi-Check® feature guards against pressure loss when shifting from “advance” to “hold” position.

Used on these pumps: P460, PA17, PA46, PA55, PE17, PE21, PE30, PE46, PE55, PE120, PQ60, PQ120, PE400, PG30, PG55, PG120 and PG400 series.

Order No.	Description
9520	3-way/3-position (tandem center) manual valve. Wt., 2,3 kg.

CAUTION: To prevent sudden, uncontrolled descent of a load as it is being lowered, use a 9596 Load-Lowering Valve or 9720 Counter Balance Valve in conjunction with the directional valve used in your application.

NOTE: Valves 9501, 9502, 9504 and 9507 can have a port blocked or have a closed center position. When a port is blocked and the valve is shifted to the blocked port, the pump will generate excessive heat. An electric or rotary air pump can either be turned off manually or with a pressure switch. Reciprocating air pumps may be adjusted to stall out and stop.

NOTE: Gauge ports monitor pump pressure only, not pressure to the hydraulic cylinder(s).

IMPORTANT: Conversion kit 251528 must be used when mounting any of the valves on this page on PA17 or PE17 pumps.

IMPORTANT: When ordering any valve for a PE30 or PG30 series pump, 12,7 mm longer mounting screws are required. For valves 9502 and 9520, order four 12001 cap screws. For valve 9576, order four 17428 cap screws.

4-WAY/3-POSITION (TANDEM CENTER) VALVE WITH POSI-CHECK®

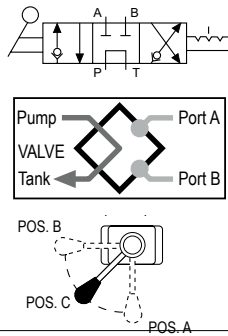

Applications: Single or double-acting cylinders.

Actuation: Lever-operated, detent-positioned.

Functions: "Advance," "hold" and "return." The Posi-Check® feature guards against pressure loss when shifting from "advance" to "hold" position.

Used on these pumps: P460, PA6D, PA17, PA46, PA55, PE17, PE21, PE30, PE46, PE55, PE84, PE120, PE400, PED, PG30, PG55, PG120, PG400, PQ60 and PQ120 series.

Order No.	Description
9506	4-way/3-position (tandem center) manual valve. Wt., 2,3 kg.

4-WAY/3-POSITION (TANDEM CENTER) AND (OPEN-CENTER) MANUAL VALVES

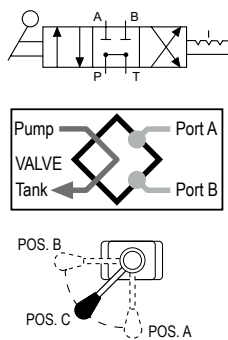

Applications: Single or double-acting cylinders.

Actuation: Lever-operated, detent-positioned.

Functions: The 9500 provides "advance," "hold" and "return." The 9511 (open center) valve can be used if holding is not a requirement, as when running two separate hydraulic tools. Provides "advance" and "return" only.

Used on these pumps: P460, PA17, PA46, PA55, PE17*, PE21, PE30, PE46, PE55, PE120, PE400, PG30, PG55, PG120, PG400, PQ60 and PQ120 series.

*Does not mount without 251528.

Order No.	Description
9500	4-way/3-position (tandem center) manual valve. Wt., 1,9 kg.
9511	4-way/3-position (open center) manual valve. Wt., 1,9 kg.

4-WAY/3-POSITION (CLOSED CENTER) MANUAL VALVE WITH POSI-CHECK®

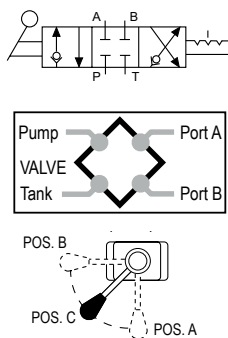

Applications: Single or double-acting cylinders.

Actuation: Lever-operated, detent-positioned.

Functions: Similar to 9506, but is a closed center valve with Posi-Check®. Generally used to operate multiple cylinders with a single pump. Provides "advance," "hold" and "return." The Posi-Check® feature guards against pressure loss when shifting from the "advance" to "hold" position. See note below regarding plugging of ports and resulting heat build-up.

Used on these pumps: P460, PA17, PA46, PA55, PA60, PA6D, PE17, PE21, PE30, PE46, PE55, PE120, PE400, PQ60 and PQ120 series.

Order No.	Description
9507	4-way/3-position (closed center) manual valve. Wt., 2,3 kg.

4-WAY/3-POSITION (CLOSED CENTER) MANUAL VALVE

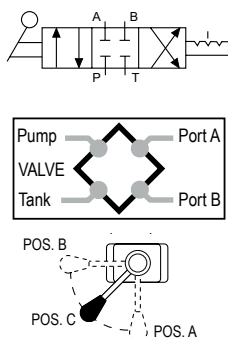
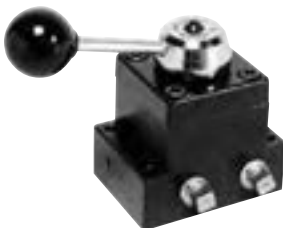

Applications: Single or double-acting cylinders.

Actuation: Lever-operated, detent-positioned.

Functions: "Advance," "hold" and "return." Closed center design makes valve suitable for operating multiple cylinders from a single pump. See note below regarding plugging of ports and resulting heat build-up.

Used on these pumps: P460, PA17, PA46, PA55, PA60, PE17, PE21, PE30, PE46, PE55, PE120, PE400, PQ60 and P120 series.

Order No.	Description
9501	4-way/3-position (closed center) valve. Wt., 1,9 kg.

NOTE: All valves on this page may be remote-mounted with a 9510 sub-plate. Valves 9501, 9502, 9504 and 9507 can have a port blocked or have a closed center position. When a port is blocked and the valve is shifted to the blocked port, the pump will generate excessive heat. An electric or rotary air pump can either be turned off manually or with a pressure switch. Reciprocating air pumps may be adjusted to stall out and stop.

3-WAY/3-POSITION (TANDEM CENTER) SOLENOID VALVES WITH POSI-CHECK®

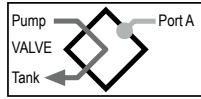
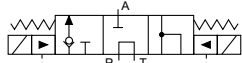

Applications: Single-acting cylinders.

Actuation: Solenoid-operated: 9605 is 115V, 50/60 Hz; 9599 is 24V, 50/60 Hz.

Functions: "Advance," "hold" and "return" positions. When in "advance," solenoid "B" is energized and oil goes from pump to cylinder through pressure port. In "return" position, solenoid "A" is energized and oil is directed from cylinder and pump to reservoir. With both solenoids de-energized, in "hold" position, oil from pump is directed back to reservoir while oil is checked in cylinder. The Posi-Check® feature holds load when shifting from "advance" to "hold" position.

Used on these pumps: Furnished with pilot lines and adapters for PE55, PE30 (carrying handles must be removed) and PE120 series. For application on other models, consult factory.

Order No.	Description
9605	3-way/3-position (tandem center) solenoid valve, 115V, 50/60 Hz. Wt., 6,4 kg.
9599	3-way/3-position (tandem center) solenoid valve, 24V, 50/60 Hz. Wt., 6,4 kg.

NOTE: Valves above are shipped without controls. Use 202777 remote hand control. Consult factory for field installation.

3-WAY/4-POSITION MANUAL PRESSURE COMPENSATED VALVE

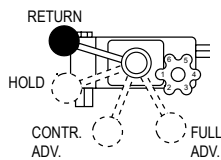
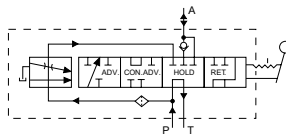

Applications: Single-acting cylinders. Primarily for use in testing soil, rock, concrete, asphalt and related engineering materials.

Actuation: Lever and adjustable, pressure compensated flow control valve.

Functions: Cylinder piston "return," "hold," "controlled advance" (pressure compensated) and "advance" (full flow). Will deliver a relatively constant flow regardless of pressure between 70 and 700 Bar.

Used on these pumps: PA17, PA46, PA55, PE17, PE21, PE30*, PE46, PE55, PE200, PE400, PG30*, PG55, PG120, PG400, PQ60 and PQ120 series. * NOTE: Adapter kit 252161 is required for mounting this valve to a PE30 or PG30 series pump.

Order No.	Description
9609	3-way/4-position manual pressure compensated valve. Wt., 4 kg.



Pressure compensated valve performance chart

Flow

Full flow position - 19 l (Ref.)
Metered advance position
1 l/min. (Max.)

Pressure

Min. working pressure - 70 bar.
Max. working pressure - 700 bar.
Max. valve case pressure - 35 bar.

Chart to the right reflects valve performance when "metered advance" position is selected.

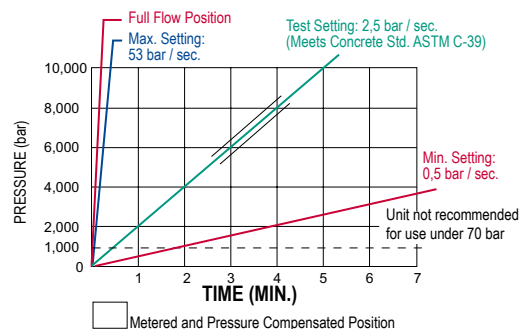

CAUTION: To prevent sudden, uncontrolled descent of a load as it is being lowered, use a 9596 Load-Lowering Valve or 9720 Counter Balance Valve in conjunction with the directional valve used in your application.

IMPORTANT: Conversion kit 251528 must be used when mounting the 9609 valve on PA17 or PE17 pumps.

IMPORTANT: When ordering any valve for a PE30 or PG30 series pump, 12,7 mm longer mounting screws are required. For valves 9500, 9501 and 9511, order four 12001 cap screws. For valve 9552, 9506, and 9507, order four 11956 cap screws. For valves 9599 and 9605, order four 251078 cap screws. For valve 9609, order four 10855 cap screws.

3-WAY/2-POSITION SOLENOID VALVE

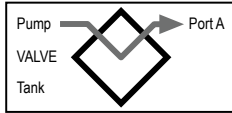
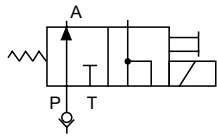

Applications: Single-acting cylinders.

Actuation: Solenoid-operated, 115V, 50/60 Hz.

Functions: Cylinder piston advances when solenoid is de-energized and pump is running. When solenoid is energized, oil is directed to reservoir, and piston returns. For "hold" position, pump is stopped with solenoid de-energized.

Used on these pumps: PE17, PE21, PE30, PE46, PE55, PE120, PE400, PQ60 and PQ120 series.

Order No.	Description
9579	3-way/2-position solenoid valve, 115V, 50/60 Hz., Wt. 4,4 kg
9569	3-way/2-position solenoid valve, 24V, 50/60 Hz., Wt. 4,4 kg
9570	3-way/2-position solenoid valve, 230V, 50/60 Hz., Wt. 4,4 kg

NOTE: Valves above are shipped without control switch. Use 202777 remote hand switch. When this valve is mounted, the pump must be equipped with an outlet check valve.

3/4-WAY/2-POSITION SOLENOID VALVES

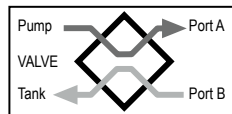
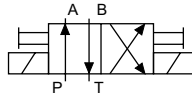

Applications: Single or double-acting cylinders. When used with single-acting cylinders, one port should be plugged.

Actuation: Solenoid-operated, 115V, 50/60 Hz.

Functions: Oil is directed to "extend" side of cylinder, oil from "retract" side goes to reservoir; cylinder "holds" with pump shut-off. Oil is directed to "retract" side of cylinder; oil from "extend" side goes to reservoir. **NOTE:** Cylinder will not "hold" in the "return" position with motor running or shut-off.

Used on these pumps: 9552, 9572 and 9592 are used with PE17, PE30 (with carrying handles removed), PE46, PE55, PE400, PQ60 and PQ120 series.

Order No.	Description
9592	3/4-way/2-position solenoid valve, 115V, 50/60 Hz., Wt. 6,6 kg
9552	3/4-way/2-position solenoid valve, 230V, 50/60 Hz., Wt. 6,6 kg
9572	3/4-way/2-position solenoid valve, 24V, 50/60 Hz., Wt. 6,6 kg

NOTE: Valves above are shipped without controls. The 9552, 9572 and 9592 can be used with the 304718 remote hand control.

NOTE: Ports are 1/4" NPTF.

AIR ACTUATED VALVE

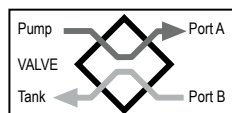
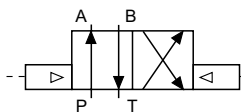

Applications: Single or double-acting cylinders. When used with single-acting cylinders, one port should be plugged.

Actuation: Air-operated.

Functions: Oil is directed to "extend" side of cylinder, oil from "retract" side goes to reservoir, cylinder "holds" with pump shut-off. Oil is directed to "retract" side of cylinder, oil from "extend" side goes to reservoir.

NOTE: Cylinder will not "hold" in the "return" position with motor running or shut-off.

Used on these pumps: PA17, PA46 and PA55 series.

Order No.	Description
9594	3/4-way/2-position solenoid valve, air-operated (minimum of 4 bar air pressure required). Wt., 5 kg.

NOTE: Valve above is shipped without controls. 9594 can be used with the 209593 remote hand control.

CAUTION: To prevent sudden, uncontrolled descent of a load as it is being lowered, use a 9596 Load-Lowering Valve or 9720 Counter Balance Valve in conjunction with the directional valve used in your application.

IMPORTANT: Conversion kit 251528 must be used when mounting any of the valves on this page on PA17 or PE17 pumps.

IMPORTANT: When ordering any valve for a PE30 or PG30 series pump, 12,7 mm longer mounting screws are required. For valves 9569, 9570 and 9579, order four 10856 cap screws. For valves 9552, 9572 and 9592, order four 12001 cap screws.

4-WAY/3-POSITION (OPEN CENTER) SOLENOID VALVE

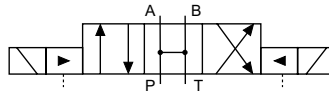

Applications: Double-acting cylinders.

Actuation: Solenoid-operated, 115V, 50/60 Hz.

Functions: "Advance," open center and "return" positions. Cylinder ports and pump port are open to reservoir in "neutral."

Used on these pumps: Furnished with pilot lines and adapters for PE30 (with carrying handles removed), PE55 and PE120 series. For other pump models, consult factory.

NOTE: A pressure switch and/or gauge may be attached if desired.

Order No.	Description
9590	4-way/3-position (open center) solenoid valve, 115 volt, 50/60 Hz., Wt. 7 kg.
9522	4-way/3-position (open center) solenoid valve, 230 volt, 50/60 Hz., Wt. 7 kg.
9615	4-way/3-position (open center) solenoid valve, 24 volt, 50/60 Hz., Wt. 7 kg.

4-WAY/3-POSITION (TANDEM CENTER) PILOT-OPERATED SOLENOID VALVE

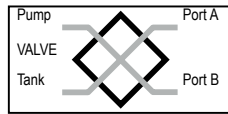
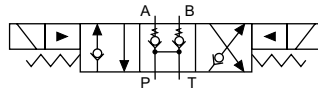

Applications: Double-acting cylinders.

Actuation: Solenoid-operated, 115V, 50/60 Hz.

Functions: "Advance," "hold" and "return." The Posi-Check® feature holds the load when shifting from the "advance" to the "hold" position.

Used on these pumps: PE17, PE21, PE30 (with carrying handles removed), PE46, PE55, PE120, PE400, PQ60 and PQ120 series.

NOTE: A gauge may be attached if desired.

Order No.	Description
9513	4-way/3-position (tandem center) solenoid valve, 115V, 50/60 Hz., Wt. 8,2 kg.
9512	4-way/3-position (tandem center) solenoid valve, 24V, 50/60 Hz., Wt. 8,2 kg.
9516	4-way/3-position (tandem center) solenoid valve, 12V, Wt. 8,2 kg. For use on the PG1204S and PG400 series pumps only.
9519	4-way/3-position (tandem center) solenoid valve, 230V, 50/60 Hz., Wt. 8,2 kg. Consult factory for field installation.

3-WAY/2-POSITION (PILOT-OPERATED, NORMALLY OPEN) SOLENOID VALVE

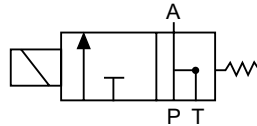

Applications: Single-acting cylinders.

Actuation: Solenoid-operated, 115V, 50/60 Hz.

Functions: "Advance" and "return."

Used on these pumps: Furnished with pilot lines and adapters for PE30 (with carrying handles removed), PE55 and PE120 series. For other pump models, consult factory.

NOTE: A pressure switch and/or gauge may be attached if desired.

Order No.	Description
9589	3-way/2-position (pilot-operated) solenoid valve, 115V, 50/60 Hz., Wt. 3,7 kg.
9523	3-way/2-position (pilot-operated) solenoid valve, 230V, 50/60 Hz., Wt. 3,7 kg.
9553	3-way/2-position (pilot-operated) solenoid valve, 24V, 50/60 Hz., Wt. 3,7 kg.

CAUTION: To prevent sudden, uncontrolled descent of a load as it is being lowered, use a 9596 Load-Lowering Valve or 9720 Counter Balance Valve in conjunction with the directional valve used in your application.

IMPORTANT: Conversion kit 251528 must be used when mounting the 9609 valve on PA17 or PE17 pumps.

IMPORTANT: When ordering any valve for a PE30 or PG30 series pump, 12,7 mm longer mounting screws are required. For valves 9513 and 9519, order four 11956 cap screws. For valves 9523, 9553 and 9589, order four 10855 cap screws. For valves 9522, 9590 and 9615, order four 10854 cap screws.

NOTE: Valves above are shipped without control switch.

4-WAY/3-POSITION (TANDEM CENTER) MANUAL VALVE

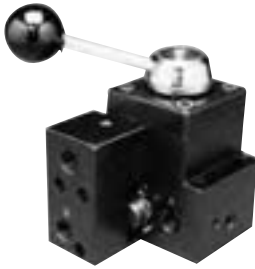

Designed for use with Power Team air, gas-line and electric powered hydraulic pumps.

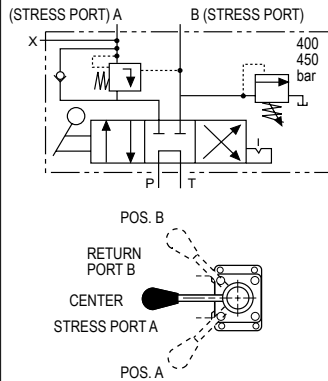

Applications: Single strand, double-acting stressing jacks with Power Wedge seater.

Actuation: Lever-operated, detent-positioned.

Operation:
With valve in center position, pump is started.

Cable is inserted into stressing tool, valve is placed in "A" position. "Pull" portion of stressing tool is pressurized to specified level for proper cable tensioning ("A" port is checked internally, can only be released by building pressure in "B" position).

Valve is placed in "B" position, which is pressure controlled and will not exceed 440 bar. "Return" portion of stressing tool is pressurized and will release "A" port when pressure reaches approximately one-half the "A" port pressure. "A" port remains open as long as this pressure differential is maintained.

Pump is stopped, valve is placed in "A" position, releasing "B" port pressure.

Used on these pumps: PA17*, PA46*, PA55, PE17*, PE21*, PE30, PE46*, PE55, PE60, PE120, PE400, PG30*, PG55, PG120, PG400, PQ60 and PQ120 series.

* These pumps may have reduced first flow stage characteristics due to internal valve restrictions.

Order No.	Description
9628	Post-tensioning valve for 700 Bar (max.) single-acting/Power Wedge seater. Wt., 2,4 kg.

"TWIN" 4-WAY/3-POSITION (TANDEM CENTER) MANUAL VALVE

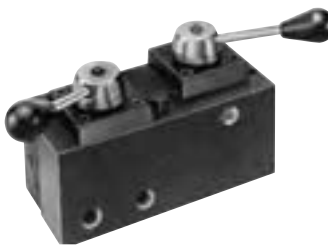

Pump-mounted, 6-position detented 5-way manual dual valve. Rated pressure to valve "A" is 700 Bar and valve "B" is 420 bar. Case pressure is 35 bar max.

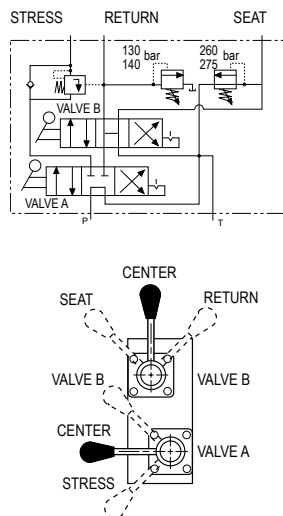

Applications: Multi-strand, double-acting stressing jacks with an auxiliary seating cylinder.

Actuation: Dual lever-operated, detent-positioned.

Operation:
With valves "A" and "B" in center position, pump is started, and cable is inserted into stressing tool.

Valve "A" is placed in "Stress" position and cylinder extends to tension cable. Pump pressure controls force exerted by tensioning cylinder in this position. "Stress" port is checked internally, and can only be released by building pressure in the valve "B" return position.

When desired cable tension is achieved, valve "A" is placed in valve "B" position and valve "B" in "Seat" position. Seating portion of cylinder will be pressurized to seating pressure controlled by "Seat" relief valve (factory set to 275 bar).

Valve "B" is shifted to "Return" position, which is pressure controlled and will not exceed 155 bar. "Return" portion of stressing tool should be pressurized and will release "Stress" port when pressure reaches 15% of "Stress" port pressure.

"Stress" port will remain open and cylinder will return as long as pressure differential is maintained. "Stress" and "Seat" ports are open to reservoir.

When cylinder has fully returned, both valves are shifted to "Center" position and oil will be directed to reservoir. Maximum pressure setting for the "Seat" relief valve is 420 bar.

Used on these pumps: PA17*, PA46*, PA55, PE17*, PE21*, PE30, PE46*, PE55, PE120, PE400, PG30*, PG55, PG120, PG400, PQ60 and PQ120 series.*

* These pumps may have reduced first flow stage characteristics due to internal valve restrictions.

Order No.	Description
9632	Post-tensioning valve for 700 Bar (max.) double-acting systems. Wt., 6,2 kg.

CAUTION: To prevent sudden, uncontrolled descent of a load as it is being lowered, use a 9596 Load-Lowering Valve or 9720 Counter Balance Valve in conjunction with the directional valve used in your application.

IMPORTANT: Conversion kit 251528 must be used when mounting any of the valves on this page on PA17 or PE17 pumps.

IMPORTANT: When ordering any valve for a PE30 or PG30 series pump, 12,7 mm longer mounting screws are required. For valves 9569, 9570 and 9579, order four 10856 cap screws. For valves 9552, 9572 and 9592, order four 12001 cap screws.

OIL COOLER KITS		
	Order No.	Description
	252511	Oil cooler kit designed for use with PE604T or PE604PT pumps with 115V. Wt., 2,3 kg.
	252512	Oil cooler kit designed for use with PE604T or PE604PT pumps with 220V. Wt., 2,3 kg.

FLUID LEVEL/TEMPERATURE GAUGE	
	Displays fluid level and temperature of hydraulic oil in reservoir. 0° - 100° C. 32 mm wide and 162 mm high.
Order No.	Description
350431	Fluid level/temperature gauge.

RESERVOIR BREATHER KITS		
	Order No.	Description
	206767	Reservoir breather kit designed for use on PA17, PA55, PE17, PE55, PE120, PG55, PG120, PQ60 and PQ120 series pumps. Wt., 0,6 kg.
	250175	Reservoir breather kit designed for use on PE21 and PE46 series pumps. These kits replace the reservoir filler cap when the pump is used in dusty and dirty environments. Wt., 0,6 kg.

CASTERS	
	50,8 mm diameter casters attach to the bottom of large reservoir for portability. Sold individually. Order the amount required.
Order No.	Description
10494	Single caster wheel. Wt., 0,1 kg.

FOOT CONTROL GUARD		
	Order No.	Description
	16339	Foot Guard for use with 10461 and 251660 foot controls.

MAGNETIC STRIP		
	Order No.	Description
	207762	Magnetic strip with adhesive back can be added to No. 25017, 202777, 202778 and 304718 hand controls. Provides 2,7 kg. of holding force. Wt., 50 g.

VITON™ * SEAL KITS			
	Order No.	Use With	Model
	300507	P12	All
	300472	P23, P55	All
	300510	P59	All
	300508	P157, P159, P300	A
	300690	P157, P159	B
	300696	P300	B
	300508	P157D, P159D, P300D	A
	300693	P157D, P159D	B
	300699	P300D	B

Viton™ seal kits Can be used in all "C" and "RH" series cylinders, as well as the P12, P55, P59, P157/ P159, P157D/P159D and P300/P300D series of hand pumps. These seals are required when fire resistant hydraulic fluids are used. Not required with Flame-Out® fluid.

* Viton™ is a trademark or registered trademark of The Chemours Company

UNIVERSAL PUMP CART



Mobilize your hydraulic pumps with the PC200. The rugged tubular frame can easily handle pumps weighing up to 91 kg. With 305 mm wheels, the cart rolls easily. Just load the pump onto the cart and wheel it right to the job. The universal mounting hole pattern lets you handle a wide variety of Power Team pumps.

Cart can be used with the following pumps: PA60, PA64 and PA554 air/hydraulic pumps; PE55 series, PE183-2 and PE184-2 electric/hydraulic pumps; PE21, PQ60 and PQ120 series "Quiet" pumps; PG55 series gas engine/hydraulic pumps; and pumps with optional 19 L- and 38 L reservoirs; Nos. RP50, RP51, RP101 and RP103.
(Shown with pump, pump not included)

Order No.	Description
PC200	Universal pump cart with 305 mm wheels. Wt., 12,2 kg.

PROTECTIVE PUMP ROLL CAGE



Safeguards pump, gas engine and valves on the job site. Horizontal bars provide convenient hand holds for carrying pump, a pick-up point permits lifting unit with an overhead crane or other device. Standard equipment on PG1203 and PG1204. Can be ordered as an option with any other gas, air, or electrically driven hydraulic pump equipped with a 19 liter reservoir.

NOTE: Refer to PG1203/PG1204 pump for details.

Order No.	Description
PC200RC	Roll cage for use with PC200. (Cannot be used on pumps with 38 liter reservoirs.) Wt., 16,3 kg.
RC2GAL	Roll cage for use with PA46, PA55, PE46, PE55 pumps with 9 liter reservoirs.
RC5	Roll cage for PG55 & PG120. For use with PG120 and PG 55 series pumps. Wt., 8,8 kg.

Large capacity reservoirs

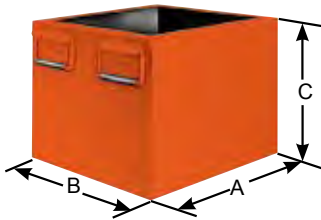

Reservoirs are equipped with drain plugs and all necessary conversion items.
Hydraulic oil is not included with reservoir kits. Please order separately.

Order No.	Cap. (l)	Usable Oil (l/min)	Use With	Size (mm.)		
				A	B	C
RP20**	7,6	7,1	PA6, PA50 series (models A-E)	292	241	165
RP20-F**	7,6	7,1	PA6 series (model F), PA 50 series (model F & G)	292	241	165
RP20M*	9,5	7,2	PA6, PA50 series (models A-E)	292	241	165
RP20M-F*	9,5	7,2	PA6 series (model F), PA50 series (model F & G)	292	241	165
RP21*	9,5	7,2	PE18 series	292	241	165
RP22†	9,5	7,1	PE55, PE120, PA55	292	241	165
RP50	19,0	18,4	PE55, PE120, PA55	457	317	216
RP51	19,0	18,4	PA46, PE21	457	317	216
RP100	37,9	35,1	PE55, PE120, PA55	457	317	368
RP101	37,9	35,1	PG55, PG120	457	317	368
RP103*	37,9	37,0	PQ60, PQ120	392	362	313
RP104	37,9	35,1	PA46, PE46, PE21	457	317	356

* Four mounting holes: 1/2"-20, for 50,4 mm diameter swivel casters (No. 10494)

** High density polyethylene reservoir.

† Aluminum reservoir.

METAL RESERVOIR CONVERSION KITS FOR PUMPS (INCLUDES GASKETS AND FASTENERS)

Pump Number	Metal Reservoir Order Number	Metal Reservoir Capacity (l)	Reservoir Wt. (kg)	Pump Number	Metal Reservoir Order Number	Metal Reservoir Capacity (l)	Reservoir Wt. (kg)	Pump Number	Metal Reservoir Order Number	Metal Reservoir Capacity (l)	Reservoir Wt. (kg)
PA6	213896	1,7	1,4	PA50	213896	1,7	1,4	PA174	213895	9,5	4,1
PA6A	213896	1,7	1,4	PA50R	213896	1,7	1,4	PE172	213895	9,5	4,1
PA6D	213896	1,7	1,4	PA6R	213896	1,7	1,4	PE172A	213895	9,5	4,1
PA6-2	213895	9,5	4,1	PA50R2	213895	9,5	4,1	PE172S	213895	9,5	4,1
PA6D2	213895	9,5	4,1	PA172	213895	9,5	4,1	PE174	213895	9,5	4,1

Model Shown:
9593

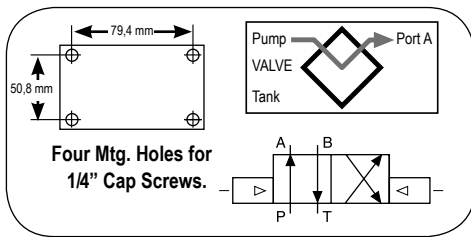

3/4-WAY / 2-POSITION SOLENOID ACTUATED VALVES

Application: Single or double-acting cylinders.

Actuation: 9593, 9524 and 9554 are solenoid-operated

Operation with single-acting cylinder: Either oil port "A" or "B" must be plugged on valve. With port "B" plugged, solenoid is energized to position "A," oil port "A" becomes pressurized. When solenoid is energized to position "B," oil port "A" becomes the return port.

Operation with multiple single-acting cylinders: A pressure line from one bank can be connected to oil port "A" and the other to oil port "B" on the valve. Sequence: When energized to position "A," oil port "A" becomes pressurized and clamps the fixture connected to oil port "A". Oil port "B" becomes a "return" port for cylinder connected to oil port "B," and retracts it. The opposite happens when solenoid "B" is energized.

Operation with double-acting cylinder: Port "A" is connected to "advance" port of cylinder, oil port "B" connects to cylinder "return" port. Solenoid is energized to position "A," oil port "A" becomes pressurized to extend cylinder piston. The opposite happens when solenoid "B" is energized. Valve does not hold in "retract" position.

NOTE: When using more than one valve on a pump, the tank port may require a check valve to permit inadvertent, momentary extension of a retracted cylinder.

NOTE: If pump is equipped with an internal outlet check, a "hold" position can be maintained with the pump shut-off.

Order No.	Description
9593	3/4-way 2-position, remote-mounted solenoid valve, 115V, 50/60 Hz., Prod. Wt. 7,0 kg.
9524	3/4-way 2-position, remote-mounted solenoid valve, 230V, 50/60 Hz., Wt. 7,0 kg.
9554	3/4-way 2-position, remote-mounted solenoid valve, 24V, 50/60 Hz., Wt. 7,0 kg.

Model Shown:
9595

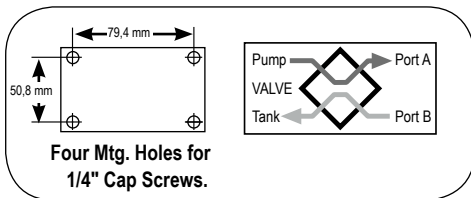

3/4-WAY / 2-POSITION AIR ACTUATED VALVES

Application: Single or double-acting cylinders.

Actuation: 9595 is air-operated.

Operation with single-acting cylinder: Either oil port "A" or "B" must be plugged on valve. With port "B" plugged, solenoid is energized to position "A," oil port "A" becomes pressurized. When solenoid is energized to position "B," oil port "A" becomes the return port.

Operation with multiple single-acting cylinders: A pressure line from one bank can be connected to oil port "A" and the other to oil port "B" on the valve. Sequence: When energized to position "A," oil port "A" becomes pressurized and clamps the fixture connected to oil port "A". Oil port "B" becomes a "return" port for cylinder connected to oil port "B," and retracts it. The opposite happens when solenoid "B" is energized.

Operation with double-acting cylinder: Port "A" is connected to "advance" port of cylinder, oil port "B" connects to cylinder "return" port. Solenoid is energized to position "A," oil port "A" becomes pressurized to extend cylinder piston. The opposite happens when solenoid "B" is energized. Valve does not hold in "retract" position.

NOTE: When using more than one valve on a pump, the tank port may require a check valve to permit inadvertent, momentary extension of a retracted cylinder.

NOTE: If pump is equipped with an internal outlet check, a "hold" position can be maintained with the pump shut-off.

Order No.	Description
9595	3/4-way 2-position, remote-mounted air-operated solenoid valve (minimum of 3,5 bar air pressure required), Prod. Wt. 5,2 kg.

CAUTION: To prevent sudden, uncontrolled descent of a load as it is being lowered, use a 9596 Load-Lowering Valve or 9720 Counter Balance Valve in conjunction with the directional valve used in your application.

CAUTION: The Posi-Check® feature will not hold the load when shifted directly A to B-B to A or from hold to A or B.

NOTE: Maximum tank line pressure for remote-mounted valves is 35 bar.

Model Shown:
9508

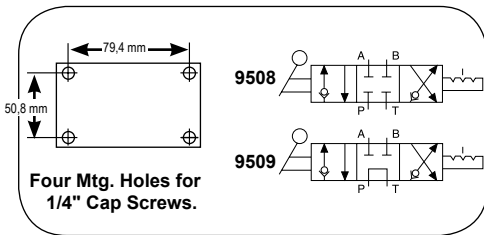
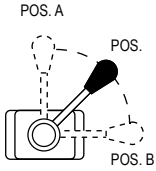

4-WAY / 3-POSITION (CLOSED CENTER) AND (TANDEM CENTER) MANUAL VALVES WITH POSI-CHECK®

Application: Single or double-acting cylinders. When used with single-acting cylinders, one port must be plugged. For double-acting cylinders, either port can be used to "advance" or "return."

Actuation: Lever-operated, detent-positioned.

Functions: The 9508 provides "advance," "hold" and "return" positions with all ports blocked (closed center) in the "hold" position. The 9509 has "advance," "hold" and "return" with tandem center (cylinder ports are blocked, pump remains running). Both valves have Posi-Check® feature to guard against pressure loss when shifting from "advance" to "hold."

Order No.	Description
9508	4-way 3-position (closed center) manual valve, including sub-plate for remote mounting. Wt., 2,9 kg.
9509	4-way 3-position (tandem center) manual valve, including sub-plate for remote mounting. Wt., 2,9 kg.

9508

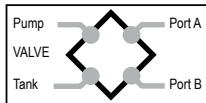

9509

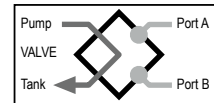

Model Shown:
9526

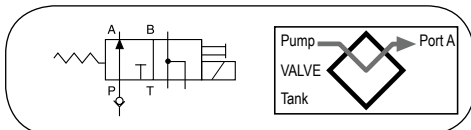

3-WAY / 2-POSITION SOLENOID VALVE

Application: Single-acting cylinders.

Actuation: Solenoid-operated, 115/230/24V, 50/60 Hz.

Function: Advances cylinder piston when solenoid is de-energized, and pump is running. When solenoid is energized, oil is directed back through valve "return" port and cylinder piston returns. To place cylinder in "hold" position, pump must be stopped or its flow held at the valve "pressure" port with the solenoid de-energized.

NOTE: Valve is equipped with a 9631 snubber valve in port "A." The line from the "return" port of the valve must be unrestricted (100 bar back pressure maximum) back to the reservoir.

IMPORTANT: A 9580 in-line check valve must be installed in the "pressure" port if the supply pump is not equipped with an outlet check valve.

NOTE: Valves above are shipped without control switch. Use 202777 remote hand switch.

Order No.	Description
9559	3-way 2-position solenoid valve, 115V 50/60 Hz. Includes a remote mounting sub-plate. Wt., 4,4 kg.
9526	3-way 2-position solenoid valve, 230V 50/60 Hz. Includes a remote mounting sub-plate. Wt., 4,4 kg.
9556	3-way 2-position solenoid valve, 24V 50/60 Hz. Includes a remote mounting sub-plate. Wt., 4,4 kg.

Model Shown:
9514

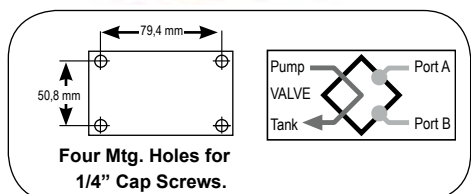

4-WAY / 3-POSITION (TANDEM CENTER) SOLENOID VALVE WITH POSI-CHECK®

Application: Double-acting cylinders.

Actuation: Solenoid-operated, 115/230/24V, 50/60 Hz.

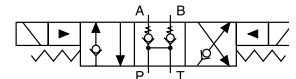

Functions: Push button control of "advance," "hold" and "return." The Posi-Check® feature guards against pressure loss when shifting from "advance" to "hold." With valve in "hold" position, cylinder ports are blocked and oil is directed from pump to reservoir.

NOTE: Do not allow return tank pressure to exceed 500 bar at the valve, Consult factory before installing a pressure switch on any of these valves.

Order No.	Description
9514	4-way 3-position (tandem center) solenoid valve, 115V, 50/60 Hz. Remote hand control included. Wt., 4,6 kg.
9525	4-way 3-position (tandem center) solenoid valve, 230V, 50/60 Hz. Remote hand control included. Wt., 4,6 kg.
9555	4-way 3-position (tandem center) solenoid valve, 24V, 50/60 Hz. Remote hand control included. Wt., 4,6 kg.

Accessories

LOAD-LOWERING VALVE

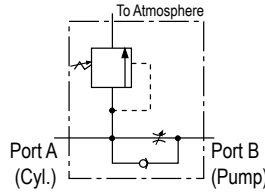

Application: Precision metering for controlled cylinder piston return.

Operation: Permits free flow when extending cylinder, built-in pressure relief and Posi-Check® locks and holds load in raised position until operator opens valve. May be pre-set to provide consistent metered return, or operator may select rate of return with each actuation. Has 3/8" NPTF ports.

NOTE: Pressure relief valve setting is 830 bar. Operating pressure is 700 Bar and max. flow rate is 19 l/min.

Order No.	Description
9596	Load-lowering valve. Wt., 1 kg.

SEQUENCE VALVE

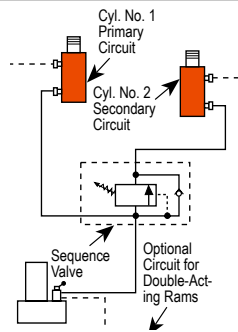
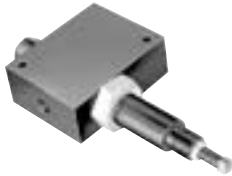

Application: Used when one cylinder in a multi-cylinder application must advance before any other.

Operation: Pump is connected to port "P" and separate cylinders to ports "A" and "B." When pressure is applied to port "P," cylinder "A" advances. Cylinder "B" will not advance until a predetermined pressure setting is reached in cylinder "A." Pressure setting is adjustable from 35 to 550 bar with adjustment screw (factory preset at 70 bar). Has 3/8" NPTF ports.

Order No.	Description
9597	Pressure control sequencing valve. Wt., 2,5 kg.

PRESSURE REDUCING VALVE

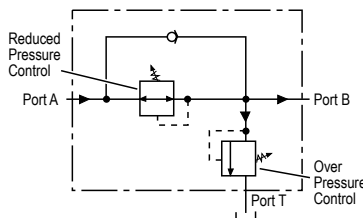

Application: Provides complete, independent pressure control to two or more clamping systems operated by a single power source.

Operation: Can be used to provide different pressures in various stages of a single system. Virtually zero leakage across valve means each system can be operated by a single continuous pressure source. Adjustable from 70 to 350 bar at outlet port "B" (secondary). Has 1/4" NPTF ports.

Order No.	Description
9608	Pressure reducing valve. Wt., 2,6 kg.

CAUTION: Over Pressure control must be set at a higher value than operating pressure.

COUNTER BALANCE VALVE

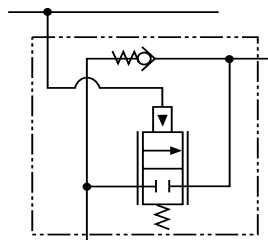

Application: Double-acting cylinders. Provides positive holding and controlled, "chatter-free" lowering of a load.

Operation: Load is raised at flow rate of pump, and held when pump is shut-off. When the pump is shifted to "retract," the counter balance valve will continue to hold the load until system pressure exceeds pressure caused by load. The load can then be lowered smoothly to the flow rate of the pump. The counter balance valve is designed to operate with pumps having a high pressure flow rate of up to 1,9 l/min. and cylinder ratios of 3 to 1.

Order No.	Description
9720	Counter balance valve, including two pairs of fittings (male and female), hydraulic hoses, and dust caps. Wt., 4,5 kg.
9721	Counter balance valve, including two pairs of fittings (male and female), but does not include couplers, hoses, fittings and dust caps. Wt., 4,2 kg.

CAUTION: The 9720 patented counter balance valve has a pilot pressure as high as 210 bar. Because this pressure is applied to the rod end of the cylinder while it is already under load, the system should not be sized for loads greater than 80% of cylinder rated capacity. To prevent sudden, uncontrolled descent of a load as it is being lowered, use a 9596 Load-Lowering Valve or 9720 Counter Balance Valve in conjunction with the directional valve used in your application.

METERING VALVE

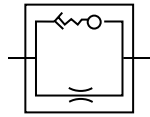

Application: For systems using large cylinders or extended lengths of hydraulic hose.

Operation: Controls surges by restricting flow if it exceeds 26,5 l/min. When flow subsides, valve reopens automatically. Has 3/8" NPTF male end to thread into return port of system control valve, and a 3/8" NPTF female end, permitting return hose to be directly connected.

Order No.	Description
9631	Metering valve. Wt., 0,1 kg.

"IN-LINE" PRESSURE REGULATOR VALVE

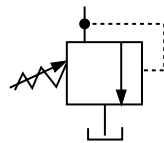

Application: Single or double-acting cylinders. Permits adjusting operating pressures at various values below relief valve setting of pump.

Operation: Regulator valve is easily adjusted to maintain pressures between 20 and 700 Bar. Maintains a given pressure setting within 3% over repeated cycles. Flow range is 0,3 l/min to 23 l/min.

Order No.	Description
9633	In-line pressure regulator valve with two 3/8" NPTF inlet ports, one 1/8" NPTF tank port and 1 m drain line kit. Wt., 1.9 kg

RELIEF VALVE



Application: Provide an economical means of protecting a hydraulic circuit against over pressurization.

Operation: These factory preset valves are designed for maximum flow rate of 19 l/min. Furnished with 1/8" NPTF male port. All valves weigh 0,1 kg. See chart below for ordering information.

NOTE: Care should be exercised to protect workers from hot, pressurized hydraulic oil. Install these valves only in an enclosed or shielded area.



Typical Set-Up

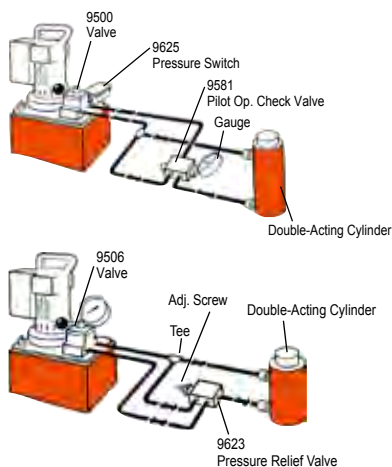

Relief Valve Order No.	Pressure Setting* (bar)	Relief Valve Order No.	Pressure Setting* (bar)
RV21278	697/738	RV21278-50	352/393
RV21278-6	41/44	RV21278-52	366/407
RV21278-10	62/69	RV21278-55	386/428
RV21278-15	103/117	RV21278-57	400/442
RV21278-17	110/124	RV21278-60	421/462
RV21278-20	131/152	RV21278-65	455/497
RV21278-25	159/186	RV21278-70	490/531
RV21278-27	179/193	RV21278-75	524/566
RV21278-28	186/207	RV21278-80	559/600
RV21278-30	207/235	RV21278-83	580/621
RV21278-32	214/228	RV21278-86	600/642
RV21278-35	241/262	RV21278-88	614/662
RV21278-38	283/310	RV21278-90	628/669
RV21278-40	304/331	RV21278-114	793/834
RV21278-43	338/366	RV21278-6280	440/476
RV21278-48	352/393	*All RV's are Preset - Non-Serviceable	

SHUT-OFF VALVE

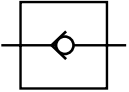
		<p>Application: This needle valve permits fine metering of hydraulic oil</p> <p>Operation: Can be used for controlling multiple single-acting cylinders.</p>	
		Order No.	Description
		9575	Shut off valve with 3/8" NPTF ports. Wt., 0,6 kg.

CHECK VALVE

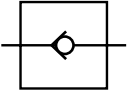
		<p>Application: Permits flow of hydraulic oil in one direction only.</p> <p>Operation: Installs right in hydraulic line.</p>	
		Order No.	Description
		9580	Check valve with 3/8" NPTF male ends. Wt., 0,2 kg.

PILOT-OPERATED CHECK VALVE

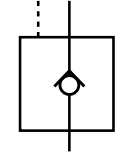
		<p>Application: For use with open or tandem center valves. Permits free flow of fluid in one direction.</p> <p>Operation: Flow is blocked in opposite direction until pilot oil pressure is applied. This prevents the loss of pressure if the valve is inadvertently shifted or the pump line is broken. Minimum cracking pressure is 4,1 bar. Required pilot pressure is approximately 16% of checked system pressure.</p>	
		Order No.	Description
		9581	Pilot-operated check valve with 3/8" NPTF ports. Wt., 1,7 kg.

"IN-LINE" PRESSURE RELIEF VALVE

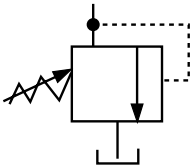
		<p>Application: Single or double-acting cylinders. For remote locations in a hydraulic circuit where maximum pressure requirements are less than basic overload valve setting in pump.</p> <p>Operation: Adjustable from 70 to 700 Bar. Valve is spring-loaded and direct-acting.</p>	
		Order No.	Description
		9623	Pressure relief valve with 3/8"NPTF ports. Wt. 0,9 kg.

Model Shown:
9639, 9638



Performance Requirements

For additional technical information or to order a **Material Safety Data Sheet** call 1-800-477-8326 or go to www.powerteam.com.

Features

STANDARD HYDRAULIC OIL

- For dependable performance of all your hydraulic pumps and cylinders.
- Contains foam suppressant additives and has a high viscosity index.

FLAME-OUT® 220 FIRE RESISTANT HYDRAULIC FLUID*

- Contains anti-rust, anti-foam and anti-sludge additives.
- Provides fire resistant protection. Note: Will burn if heat source is extreme enough. Will not, however, propagate the flame and is self-extinguishing when there is no ignition source.
- Provides maximum lubrication and heat transfer.
- Offers a wider operating temperature range.
- No need to change seals in your Power Team equipment. Just drain the standard oil and replace it with Flame-Out® 220.

BIODEGRADABLE HYDRAULIC FLUID

- Biodegradable, non-toxic fluid withstands moderate to severe operating conditions. Provides excellent protection against rust.
- Offers superior anti-wear properties and has excellent multi-metal compatibility.

LOW TEMPERATURE OIL

- Provides smooth, reliable operation in the coldest climate conditions.

Technical Specifications

Description	Grade (ASTM)	Specific Gravity @ 16°C (kg/l)	Color (ASTM)	Flash Point	Fire Point	Pour Point	Viscosity		Viscosity Index	Foam Test (ASTM)
							SUS @ 38°C	SUS @ 99°C		
Standard Oil	215	0,88	2 Amber	204°C	221°C	-34°C	215	48	100 min.	Pass
Flame-Out®	220	0,91	Light Amber	260°C	288°C	-26°C	220	55	140 min.	Pass
Biodegradable	—	0,92	2 Amber	224°C	NA*	-30°C	183	53	213 min.	Pass
Low Temp.	—	0,87	6.5 Red	180°C	204°C	-45°C	183	52	190 min.	Pass

Ordering Information

Order Number	Oil Description	Quantity
9636	Standard Oil	0,9
9637		3,8
9638		9,5
9616		208
9639	Flame-Out®	3,8
9640		9,5
9645	Biodegradable	3,8
9646		9,5
9647	Low Temperature	3,8

ON/OFF MOTOR CONTROL

The following remote control switches will give you momentary "ON" control of your hydraulic pump. These switches are deadman type, spring loaded to the "OFF" position. They can be used with any Power Team electric hydraulic pump.



Order No.	Description
25017	Remote hand control. Has a push button switch, with a 3 m cord. Wt., 0,4 kg.
203225	Remote hand control. Heavy-duty with single push button switch in a neoprene housing with 3 m cord. Housing seals out dust, lint and liquids (unit is not submersible). Wt., 0,4 kg.
10461	Remote foot control, with 3 m cord. Wt., 1,4 kg.
251660	Remote foot control, with 3 m cord. For use with the PE10 style pumps. Wt., 0,5 kg.

SOLENOID & MOTOR CONTROL



Order No.	Description
202777 *	Remote hand control. Has rocker style switch that is momentary advance, spring center hold and detented retract. It comes with a 3 m cord, for use with 3-way/2 or 3-position valves. Wt., 0,4 kg.
202778 **	Remote hand control. Has rocker style switch that is momentary advance, spring center hold and momentary retract. It comes with a 3 m cord, for use with 4-way/3-position valves. Wt., 0,4 kg.
304718**	Remote hand control. Has a rocker style switch that is momentary advance, spring center hold and momentary retract. The switch is wired to start and stop the motor when the valve is energized. It comes with a 3 m cord. To be used with 4-way/2-position valves. Wt., 0,4 kg.
309653	Remote foot control. Can be used in place of either of the above hand controls to control the same type of valves. The switch is momentary on, both advance and retract position, and is spring centered to the hold position. This foot switch comes with 3 m cord. Wt., 1,8 kg.
17627	Remote foot control. Same as the 309653, but without a cord. Wt., 0,9 kg.
309652	Remote foot control. Has same functions as 304718. Supplied with a 3 m cord. To be used with 4-way/2-position valves. Wt., 1,8 kg.
216209	Remote foot control. Same as the 309652, but without a cord. Wt., 0,9 kg.

* For use on solenoid valves that are used on single-acting cylinders
 ** For use on solenoid valves that are used on double-acting cylinders
NOTE: See valves listing to determine which remote to use.

REMOTE AIR MOTOR CONTROLS



This remote hand control has two momentary push buttons, one for advance and one for retract with spring offset to hold. To be used with 4-way/2-position air pilot valves.

Order No.	Description
209593	Remote hand control with 3,7 m cord. Wt., 0,9 kg.

SUB-PLATES

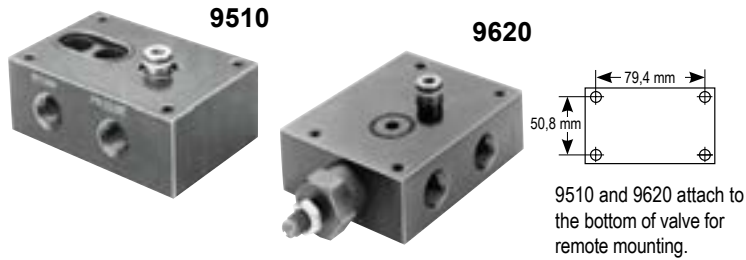

9510 and 9620 attach to the bottom of valve for remote mounting.

For remote mounting of control valves. Sub-plates convert pump-mounted valves to remote-mounted valves quickly and easily.

Order No.	Description
9510	Sub-plate for remote mounting the following valves; 9500, 9501, 9502, 9504, 9506, 9507, 9511, 9552, 9572, 9575, 9576, 9592 and 9594. Wt., 0,7 kg.
9620	For use with 9500, 9501, 9502, 9552, 9572, 9592 and 9594. Same as 9510, but has integral pressure regulating valve. Wt., 1,7 kg.

PUMP-MOUNTED SUB-PLATES

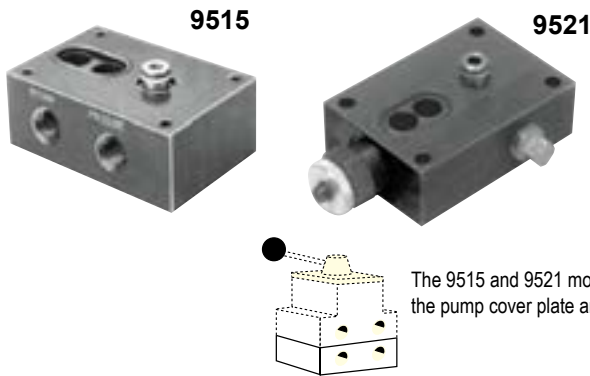

The 9515 and 9521 mount between the pump cover plate and valve.

When fitted between pump cover plate, valve mounting flange, and control valve, provides a separate 3/8" NPTF female port, open to "return" regardless of position of valve. Also provides a separate 3/8" NPTF female pressure port. This sub-plate can be useful when you desire to use one pump with a deck-mounted control valve, plus a separate remote-mounted valve to control another function.

For use with the following valves: 9500, 9501, 9502, 9504, 9506, 9507, 9511, 9520, 9552, 9572, 9575, 9576, 9592, 9594, and 9609.

Order No.	Description
9515	Sub-plate, Wt., 0,6 kg.
9521	Sub-plate for use under most pump-mounted valves to provide adjustable pressure control on units not equipped with an external pressure regulator. Wt., 1,7 kg.

AIR FILTER/REGULATOR/LUBRICATOR



Recommended for use with single-speed air/hydraulic pumps.

Order No.	Description
9531	Filter/regulator. 1/4" NPTF inlet and outlet. Wt., 0,4 kg.

PRESSURE SWITCH

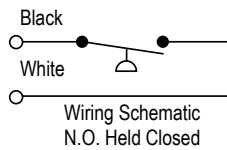

Application: Used in a hydraulic circuit where system pressure must be "held." Automatically (electrically) turns off pump motor when predetermined system pressure is reached.

Attaches directly to control valve manifold or can be mounted in-line to read system pressure. Has a 1/4" NPTF male thread, and a 1/4" NPTF fitting for gauge mounting if required. Adjustable from 70 to 700 Bar. Can also be used to actuate other electrical devices in the system. Wired normally open and held closed by spring pressure.

Order No.	Description
9625	In-line pressure switch with 1/4" NPTF gauge port. Wt., 0,5 kg.

IMPORTANT: Electrical rating of switch is 5 amps at 250V max. To prevent permanent damage to switch, a control relay must be installed to handle currents or voltage exceeding these limits. Pressure switch should never be used to directly actuate the electrical motor.

PILOT-OPERATED AIR CONTROL VALVES



Application: For use when an air pilot signal is required at a set hydraulic pressure. Can be used to shift valves, and start or stop pneumatic pumps.

Attaches directly to control manifold or can be mounted in-line to read system hydraulic pressure. Automatically turns on an air pilot signal when a predetermined system pressure is reached. Has 1/4" NPTF male thread and 1/4" NPTF fitting for gauge mounting if required. Adjustable from 35 - 700 Bar. Maximum rating of 700 l at 700 bar.

Order No.	Description
9641	Pilot-operated control valve, normally closed, with 1/4" NPTF male thread. Wt., 0,5 kg.
9643	Pilot-operated control valve, normally open, with 1/4" NPTF male thread. Wt., 0,5 kg.

Model Shown:
9755E



Accessories

Features

REINFORCED WIRE-BRAID RUBBER HOSES OFFER INCREASED DURABILITY

- Hose reinforced with 4 braids of high tensile steel wire.
- The synthetic rubber covering is oil and weather resistant.
- 3/8" NPTF fittings on both ends.
- Operating pressure is 700 Bar.

Cylinder Return Time

Cylinder No.	9769E	9781E
	3,1 m Hose 6,4 mm I.D.	3,1 m Hose 9,5 mm I.D.
C2514C	51 sec.	14 sec.
C556C	1 min., 30 sec.	24 sec.
C5513C	4 min., 12 sec.	59 sec.
C10010C	6 min., 56 sec.	1 min. 3 sec.

Hose with Coupler Half

9754E Hose assembly consisting of 9756E (1,8 m hose) with 9798 (hose half coupler) and 9800 (dust cap)

Ordering Information

Hose Type	Hose I.D. (mm)	Hose Length (m)	Burst Rating (bar)	Order Number
Rubber, Wire-Braid	6,5	0,9	3250	9755E
Rubber, Wire-Braid	6,5	1,8	3250	9756E
Rubber, Wire-Braid	6,5	1,8	3250	9754E**
Rubber, Wire-Braid	6,5	2,4	3250	9757E
Rubber, Wire-Braid	6,5	3,1	3250	9758E
Rubber, Wire-Braid	6,5	3,7	3250	9759E
Rubber, Wire-Braid	6,5	6,1	3250	9760E
Rubber, Wire-Braid	6,5	9,1	3250	9761E
Rubber, Wire-Braid	6,5	15,3	3250	9762E

Hose Type	Hose I.D. (mm)	Hose Length (m)	Burst Rating (bar)	Order Number
Rubber, Wire-Braid*	9,5	0,9	2800	9733E
Rubber, Wire-Braid*	9,5	1,8	2800	9776E
Rubber, Wire-Braid*	9,5	3,1	2800	9777E
Rubber, Wire-Braid*	9,5	4,6	2800	9734E
Rubber, Wire-Braid*	9,5	6,1	2800	9778E
Rubber, Wire-Braid*	9,5	9,1	2800	9735E
Rubber, Wire-Braid*	9,5	12,2	2800	9736E
Rubber, Wire-Braid*	9,5	15,3	2800	9779E

* High Flow

**Furnished with 9798 hose half coupler and 9800 dust cap.

Model Shown:
9767E



Features

POLYURETHANE HOSES.

- Nylon core tube with high tensile steel wire reinforcement.
- Hoses are equipped with plastic hose guards.
- Ben radius 70 mm
- Suitable for continuous service at temperatures from -40° to 100° C.



Cylinder Return Time

Cylinder No.	9769E	9781E
	3,1 m Hose 6,4 mm I.D.	3,1 m Hose 9,5 mm I.D.
C2514C	51 sec.	14 sec.
C556C	1 min., 30 sec.	24 sec.
C5513C	4 min., 12 sec.	59 sec.
C10010C	6 min., 56 sec.	1 min. 3 sec.



BE SAFE!

1. Inspect before and after each use.
2. Replace if any signs of degradation or wear that may affect safety or performance.
3. Keep the product clean.
4. Store properly.

Ordering Information

Hose Type	Hose I.D. (mm)	Hose Length (m)	Burst Rating (bar)	Order Number
Polyurethane	6,4	0,6	2800	9765E
Polyurethane	6,4	0,9	2800	9766E
Polyurethane	6,4	1,8	2800	9767E
Polyurethane	6,4	1,8	2800	9764E**
Polyurethane	6,4	2,4	2800	9768E
Polyurethane	6,4	3,1	2800	9769E
Polyurethane	6,4	3,6	2800	9770E
Polyurethane	6,4	6,1	2800	9771E
Polyurethane	6,4	15,3	2800	9772E
Polyurethane	6,4	22,9	2800	9750E
Polyurethane	6,4	30,5	2800	9751E

Hose Type	Hose I.D. (mm)	Hose Length (m)	Burst Rating (bar)	Order Number
Polyurethane*	9,5	1,8	2800	9780E
Polyurethane*	9,5	3,1	2800	9781E
Polyurethane*	9,5	6,1	2800	9782E
Polyurethane*	9,5	15,3	2800	9783E

* High Flow

**Furnished with 9798 hose half coupler and 9800 dust cap.

Model Shown:
9775



Accessories

Features

NON-CONDUCTIVE HOSE

- For applications requiring electrical isolation.
- 3/8" NPTF fittings on both ends
- Leakage factor of less than 50 micro-ampere.
- Orange polyurethane for easy identification.
- Covering is not perforated, preventing moisture from entering the hose and affecting its overall conductivity.
- Hoses feature a minimum 2800 bar burst pressure.



BE SAFE!

1. Inspect before and after each use.
2. Replace if any signs of degradation or wear that may affect safety or performance.
3. Keep the product clean.
4. Store properly.



Torque Wrench Hoses - Non-Conductive Dual Line



Order Number	Hose Length (m)	Hose I.D. (mm)
TWH15	4,6	6,4
TWH20	6	6,4
TWH30	15,2	6,4

For torque wrench tools, refer to the tool section.

Ordering Information

Order Number	Couplers / Fitting	Hose I.D. (in.)	Hose Length (m)	Burst Rating (bar)
9773	3/8" Fitting NPTF	6,4	1,8	2800
9774	3/8" Fitting NPTF	6,4	3,1	2800
9775	3/8" Fitting NPTF	6,4	6,1	2800

CYLINDER AND HOSE COUPLERS are designed for use up to 700 bar with hydraulic jacks, cylinders, etc. They are the threaded union type for interchanging cylinders in seconds. Each half is valved with a precision ball for a tight shutoff when disconnected. These couplers also permit the separation of cylinders or hose from pump when at 0 bar with minimal oil loss.

NO SPILL, PUSH TO CONNECT COUPLERS are designed to permit high oil flow, the no-spill, push-to-connect couplers with locking collar and flush face design are for high pressure applications. The flush-face concept makes it easy to clean both coupler ends before connecting. Our unique push-to-connect, “dry-break” design eliminates oil spillage. The locking collar makes accidental disconnects a thing of the past. For 700 bar operation.

	Order No.	Description		Order No.	Description
	9795	Complete quick coupler with two 9800 dust caps, 3/8" NPTF.		251410	Quick-connect, screw-on female coupling. Used on 700 bar torque wrenches, nut-splitters, hoses, and pumps. 1/4" NPT Female Thread
	9798	Male (hose) half coupler 3/8" NPTF. Includes half dust cap.		251411	Quick-connect, screw-on male nipple. Used on 700 bar torque wrenches, nut-splitters, hoses, and pumps. 1/4" NPT Female Thread
	9796	Female (cylinder) half coupler with 9800 dust cap, 3/8" NPTF.		252364	Metal dust cover for female coupler
	9796-V*	Female (cylinder) half coupler with Viton™ seals and 9797 metal dust cap, 3/8" NPTF.		252365	Metal dust cover for male coupler
	9796-E	Female (cylinder) half coupler with EPR seals and No. 9797 metal dust cap, 3/8" NPTF.		9792	No-spill, push-to-connect, Female (cylinder) half quick coupler only. (Wt., 0,14 kg.)
	9799	Optional metal dust cap (hose half).		9793	No-spill, push-to-connect, Male (hose) half quick coupler only. (Wt., 0,14 kg.)
	9797	Optional metal dust cap for cylinder half.		9794	No-spill, push-to-connect, Complete quick coupler (male and female). Dust caps not included. (Wt., 0,23 kg.)
	9800	Dust cap for male or female 3/8" NPTF half couplers. (Wt., 0,14 kg.)	* Viton™ is a trademark or registered trademark of The Chemours Company		

Model Shown:
9040E



Accessories

Features

HEAVY-DUTY HYDRAULIC PRESSURE GAUGES

- Gauges feature an easily readable and highly visible, red Day-glo® needle.
- High strength steel bourdon tube ensures high cycle life.
- Stainless steel cases and lens locking rings.
- Have 1/4" NPT connections.
- Gauges are calibrated and comply to ASME B40.1 GRADE B



Typical Set-Up - Mounting Situations

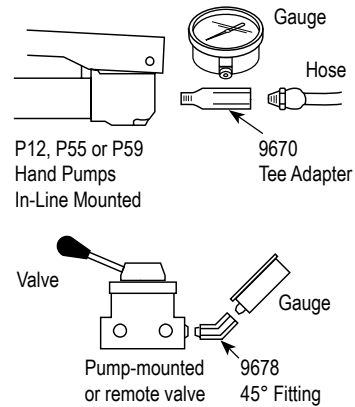

Accessories for Analog Gauges



9046 - Silicone Fill Kit

Silicone fill kit. 212 gr. Requires one bottle to fill 102 mm gauge; four bottles to fill 152 mm gauge.



9049 - Dampener Fitting

High-performance pulsation dampener. 1/4" NPTF male x 1/4" NPTF female.

Ordering Information

Order Number	Face Dia. (mm)	Pressure Range (bar)	Tonnage Range (ton)	Major Graduations (bar)	Minor Graduations (bar)	Silicone Filled (Yes/No)	Use With Cylinder Series
9040E	63,5	0 - 690	-	2000 psi, 100 bar	200 psi, 20 bar	Yes	All
9052E	101,6	0 - 690	-	1000 psi, 100 bar	100 psi, 20 bar	Yes	All
9053E	101,6	0 - 690	0-5	2000 psi, 1 Ton	200 psi, 0,1 Ton	No	C & RLS
9055E	101,6	0 - 690	0-10	2000 psi, 1 Ton	200 psi, 0,1 Ton	No*	C, RD, RH, RLS & RSS
9057E	101,6	0 - 690	0-15	2000 psi, 1 Ton	200 psi, 0,2 Ton	Yes	C
9059E	101,6	0 - 690	0-17,5, 0-30, 0-50	2000 psi, 5 Ton	200 psi, 0,5 Ton on 30, 50 Ton Scales; 0,2 Ton on 17,5 Ton Scale	No*	RT172, RT302, RT503
9061E	101,6	0 - 690	0-20	2000 psi 5 Ton	200 psi, 0,5 Ton	Yes	RH, RLS, RSS
9063E	101,6	0 - 690	0-25	2000 psi 5 Ton	200 psi, 0,5 Ton	No*	C & RD
9065E	101,6	0 - 690	0-30	2000 psi, 5 Ton	200 psi, 0,5 Ton	No*	RH†, RLS & RSS
9067E	101,6	0 - 690	0-50	2000 psi, 5 Ton	200 psi, 0,5 Ton	No*	RH†, RLS & RSS
9069E	101,6	0 - 690	0-55	2000 psi, 5 Ton	200 psi 0,5 Ton	No*	C, R, RA & RD
9071E	101,6	0 - 690	0-60	2000 psi, 5 Ton	200 psi, 1 Ton	No*	RH, except RH6010
9073E	101,6	0 - 690	0-75	2000 psi, 5 Ton	200 psi, 1 Ton	Yes	C, RLS & RD8013
9075E	101,6	0 - 690	0-100	2000 psi, 10 Ton	200 psi, 1 Ton	No*	C, R, RA, RD, RH, RLS†, RSS† & RT1004†
9077E	101,6	0 - 690	0-150	2000 psi, Initial 10 Then 20 Ton	200 psi, 2 Ton	No*	C, R, RD & RLS
9079E	101,6	0 - 690	0-200	2000 psi, 20 Ton 10 Then 20 Ton	200 psi, 2 Ton	No*	R, RD & RH†
9089	152,4	0 - 690	0-690	1000 psi, 100 bar	100 psi, 10 bar	No	All

* Shipped "dry." User can convert to "wet" using liquid silicone No. 9046.

† The tonnage scale on the gauge may vary slightly among different series cylinders due to different effective area.

Model Shown:
DG100



Features

DG100 DIGITAL PRESSURE GAUGES

- Accurate to within 1%, Long-life pressure transducer.
- Pressure values are displayed on large red LEDs in 0,7 bar or bar increments.
- “Peak” hold feature with reset toggle switch and “Peak On” indicator; Hi/Low set point feature with relay outputs for Hi/Low alarms and/or control signals.
- A slow flashing display indicates pressure below the low limit. Fast blinking display alerts if limit is exceeded.
- High and low limit relays are rated to 5 amps at 115V.
- Operating temperature of -18 to 60°C for the electronic display and -29 to 82°C for the transducer.
- Gauge housings are extruded aluminum 1/8" DIN enclosures (NEMA 1 rating).
- When power cable is connected to gauge, display will scroll all characters, performing a self- diagnostic routine.
- 1/4" NPTF male threads for the pressure connection.
- 6-foot input signal cable connects to back of display unit.

Accessories



Typical Set-Up - Mounting Situations



- **DG100** (bar) digital gauge.
- **DG100B** (bar) digital gauge.

Upgrade to **DG100** or **DG100B** when:

- Hi/Low alarms required.
- Relays triggered by Hi/Low pressure.
- Pressure display needs to be remotely mounted from measurement location.
- Accurate within 1% @ Full Scale.



Accessories for DG100



420778 - Digital Gauge Stand

Gauge stand for DG100. Has angled base mounting to hold gauge at a convenient viewing angle. Wt., 0,5 kg.



37045 - Auxiliary Power Cord

Auxiliary power cord for use with any 12 or 24V battery. Wt., 0,1 kg. *Caution: For use on negative ground systems only.*

Ordering Information

Order Number	Description	Pressure Range (bar)	Prod. Wt. (kg)
DG100 *	Digital pressure gauge	0 - 700	1
DG100B *	Digital pressure gauge	0 - 700	1

* Serviced only at factory.

Model Shown:
9042DG, 9042DG1500



Accessories

Features

- Digital gauge is easier to read and offers better accuracy than a conventional analog gauge.
- The laser welded stainless steel sensor & socket and the IP67 weatherproof rating make this product suitable for use in the most demanding of applications.
- Five pre-programmed engineering units allow technicians to read pressure in the unit of measure most applicable to the process.
- The gauge also features a bar graph display feature for enhanced visibility.
- Includes automatic-off battery conservation, pressure tare, minimum pressure memory and maximum pressure.
- Vibration & shock tested to MIL-STD-202G.
- Agency Compliance / Approval: RoHS, CE, ASME B40.7, UL, cUL 61010-1.
- The gauges are calibrated for life at the factory and can be certified in the field, if required.

▶ *Power Team's 9042DG was the perfect choice in accurately monitoring the force applied in this H frame press application.*



► Technical Attributes



- 1 Protective rubber boot
- 2 Back-light and large 12,2 mm display easy reading
- 3 Displays in multiple engineering units: psi, bar, mPa, inHg, kg/cm²
- 4 Weatherproof IP67 enclosure
- 5 2,000 hr. life, (2) AA (LR6) batteries
- 6 Typical Cycle Life: 10,000,000
- 7 1/4" NPTF Male Threads (9042DG); 9/16-18 UNF-2B (9042DG1500). High pressure 60° core port.

► Technical Specifications

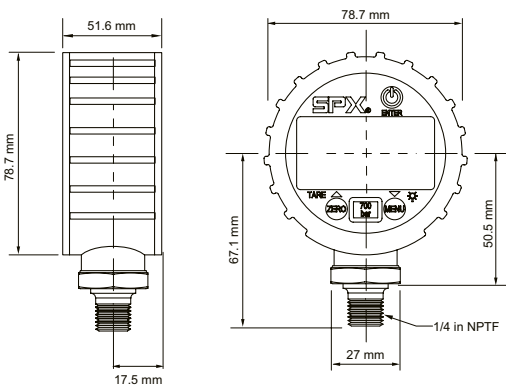

► Ordering Information

Order No.	Face Dia. (mm)	Rated Pressure (bar.)	Temp Range (°C)	Tool Use	IP Rating	Batteries Included	Battery Life (hrs.)	F.S. Accuracy	Prod. Weight (kg)
9042DG	63,5	0-700	-20 to +60	All	IP67	2 x AA (LR6)	2000	0.50%	0,24
9042DG1500	63,5	0-1500	-20 to +60	All	IP67	2 x AA (LR6)	2000	0.25%	0,24



Typical Mounting Setups for 9042DG

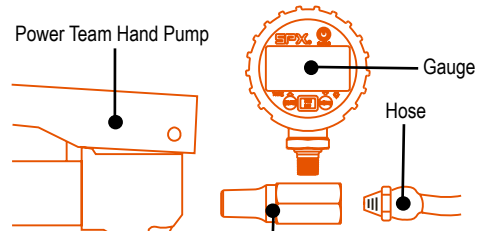

Tee adapter (No. 9670) is used for installing a gauge in line in a hydraulic circuit.

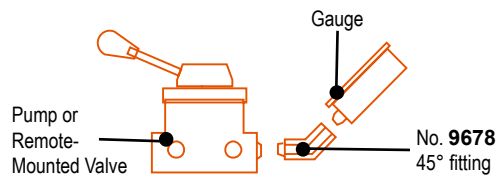

Hardware Requirements for 9042DG



- Does your pump have a 3/8" or 1/4" NPTF port?
- Are you direct-plumbing the gauge to your tool or seeking to quick-disconnect?
- Refer to the Power Team Catalog under the accessories section for a comprehensive range of fittings and couplers to meet your needs.







Custom Scale





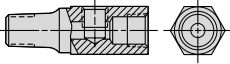
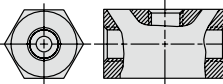
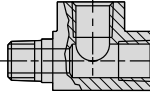
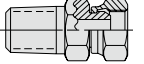
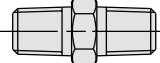
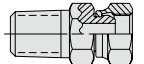
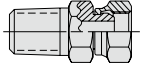
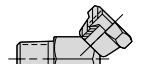
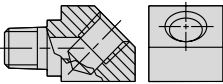
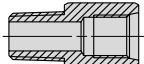

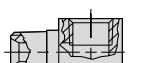

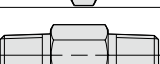
User programmable unit of measure allows you to set a custom scale to have the gauge display torque, force or weight to match the cylinder or tool being used.

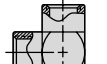

Safety Tip

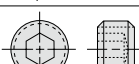
When using couplers to detach the gauge, always use a metal cover (ordered separately) on the pump side (female) coupler when the gauge is removed.

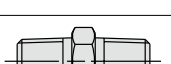
	Order No.	Description
	9190	Hydraulic tubing. 3/8" O.D. x .065" wall, 15,3 m. (10 pieces 1,53 m long.) Wt. 5,5 kg.
	9670	Tee adapter. For installing gauge between pump and hose coupling. Has 1/4" and 3/8" NPTF female and 3/8" NPTF male ports. Wt. 0,2 kg.
	9671	Double tee adapter. Permits use of more than one cylinder in series with one pump. Three 3/8" NPTF female ports. Wt. 0,5 kg.
	9672	Service tee. Two 3/8" NPTF female internal, one 3/8" NPTF male external. Wt. 0,3 kg.
	9673*	Swivel connector. 3/8" NPSM male, 1/4" NPSM female. Wt. 0,1 kg.
	9674	Male connector. 43 mm long, 1/4" x 3/8" NPTF. Wt. 0,1 kg.
	9675*	Swivel connector. 3/8" NPTF male, 3/8" NPSM female. Wt. 0,1 kg.
	9676*	Swivel connector. 1/4" NPTF male, 3/8" NPSM female. Wt. 0,1 kg.
	9677*	45° swivel connector. 3/8" NPTF male, 3/8" NPSM female. Wt. 0,1 kg.
	9678	45° fitting. Used when mounting gauge at an angle on connection such as 9670. Male and female 1/4" NPTF ends. Wt. 0,1 kg.
	9679	Connector. 1/4" NPTF female and 3/8" NPTF male. Wt. 0,1 kg.
	9680	Coupling. Both ends 3/8" NPTF female. Wt. 0,1 kg.
	9681	Street elbow. Male and female 3/8" NPTF ends. Wt. 0,1 kg.
	9682	Male connector. 43 mm long, 3/8" NPTF male ends. Wt. 0,1 kg.
	9683	Male connector. 57 mm long, 3/8" NPTF male ends. Wt. 0,1 kg.

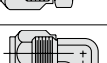
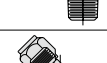
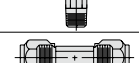
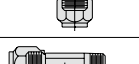
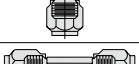
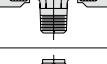
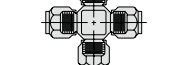
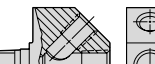





	Order No.	Description
	9684	Male connector. 57 mm long, 1/4" NPTF male ends. Wt. 0,1 kg.
	9685	Coupling. 1/4" NPTF female and 3/8" NPTF female. Wt. 0,1 kg.
	9686	90° elbow. 3/8" NPTF female ends. Wt. 0,2 kg.
	9687	Pipe plug. Heat-treated, 3/8" NPTF. Wt. 0,1 kg.
	9688	Pipe plug. Heat-treated, 1/4" NPTF. Wt. 0,1 kg.
	9689	Connector. 1/4" NPTF male and 3/8" NPTF female. Wt. 0,1 kg.
	9690	Male connector. 43 mm long, 1/4" NPTF male ends. Wt. 0,1 kg.
	9692	Straight connector. 3/8" tube x 3/8" male NPTF. Wt. 0,1 kg.
	9693	90° elbow. 3/8" tube x 3/8" male NPTF. Wt. 0,1 kg.
	9694	45° elbow. 3/8" tube x 1/4" male NPTF. Wt. 0,1 kg.
	9695	Tee. 3/8" tube. Wt. 0,1 kg.
	9696	Male run tee. 3/8" tube x 1/4" male NPTF. Wt. 0,1 kg.
	9697	Male branch tee. 3/8" tube x 1/4" male NPTF. Wt. 0,1 kg.
	9698	Cross. 3/8" tube. Wt. 0,2 kg.
	9699	45° gauge fitting. 3/8" NPTF male and female, and 1/4" NPTF female at 45°. Wt. 0,3 kg.
	9705	Fitting, swivel. 3/8" NPTF male to 3/8" NPTF female. 90° fitting with internal 370 micron screen. May be rotated 360° about male thread axis.

* **CAUTION:** On part numbers 9673, 9675, 9676 and 9677 the female swivel end of these adapters is a straight pipe thread (NPSM) with a 30° seat. All male pipe fittings that are used with these female swivel adapters must have an internal 30° seat in order to effect a proper seal. All Power Team male fittings are manufactured with a 30° seat except 9687 and 9688.

NOTE: Power Team hydraulic fittings are intended for use with our high pressure hydraulic products and are suitable for use at max. working pressures of 700 Bar unless otherwise noted.

MANIFOLD BLOCKS

Select from a wide assortment of high pressure manifold blocks to customize your system.

	Order No.	Description
	9691	"Y" Manifold. Extremely useful when connecting two hydraulic cylinders to a single line. Has three 3/8" NPTF ports. Wt. 0,45 kg.
	9634	Manifold block. This manifold is for multiple-cylinder installations, has four 3/8" NPTF ports and two 6,4 mm mounting holes. 2" Square 1.5" thick. Wt. 0,7 kg.
	9635	Manifold block. This hex-shaped manifold offers extra versatility with six 3/8" NPTF ports and two 6,4 mm mounting holes. 2.5" Hex x 1.25 thick. Wt. 0,9 kg.
	9617	Manifold block. When a multiple-cylinder installation is required, this manifold is invaluable. Has six 3/8" NPTF ports to handle larger multiple-cylinder systems. Wt. 1,4 kg.
	9648	Manifold block. This 178 mm long manifold block has seven 3/8" NPTF ports and two 6,4 mm mounting holes. Wt. 1,2 kg.
	9627	Manifold block. This 406 mm long manifold block allows you to mount the 9575 or 9596 valves without interference. Has seven 3/8" NPTF ports and two 6,4 mm mounting holes. Wt. 2,7 kg.
	9626	Pump-mounted, manifold block. Converts pump-mounted valves for use with remote-mounted valves. This manifold block is sub-plate mounted on the pump cover plate and provides 3/8" NPTF pressure and return ports. Maximum recommended flow rate is 19 l/min. Note: If used on PE30 or PG30 series pump, 12,7 mm longer mounting screws are required. Order four (4) No. 11956 screws separately.

MANIFOLD BLOCKS WITH NEEDLE VALVES

For independent multiple-cylinder operation, feature needle valves for precise manual control.

	Order No.	Description
	9642	2-Port Manifold. Manifold with two needle valves for control of two cylinders. Has four 3/8" NPTF ports. Wt. 3,7 kg.
	9644	2-Port Manifold. Manifold with four needle valves for control of four cylinders. Has six 3/8" NPTF ports. Wt. 7,3 kg.

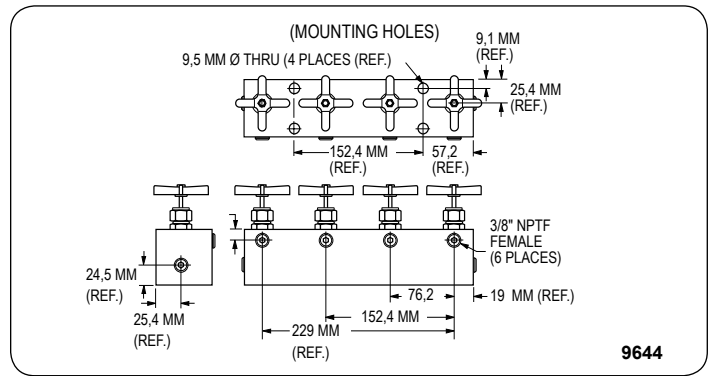
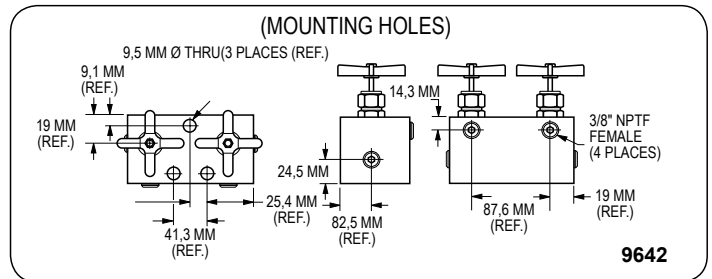

Technical Dimensions

Manifold Number	A (mm)	B (mm)	C (mm)
9617	177,8	38,1	38,1
9627	406,4	114,3	38,1
9648	177,8	38,1	38,1

