

HEAVY LIFT CYLINDERS

RGG and RDG Series

Single and double acting, high pressure cylinders



HIGH TONNAGE CYLINDERS

ENGINEERED FOR TOUGH APPLICATIONS

SPX FLOW™ brand Power Team™ specializes in high-pressure hydraulic technology. Through a broad range of leading-edge component parts, accessories and tools, Power Team enables the creation and upkeep of concentrated force delivery solutions that can meet any application criteria.

RGG Series is perfect for any bridge construction application.



Power Team's new range of cylinders has been designed for safety and reliability by incorporating the following design elements.

Overview

- **The patented self-aligning piston gland** design minimizes the effects of offset load conditions.
- **The patented deep swivel cap** provides concentrated load centering up to 5°
- **The Power-Tech nitrocarburization treatment** inhibits corrosion and provides durability in harsh applications
- **The robust retaining ring** provides full load end stop.

Safety. Durability. Power Team.

A CLOSER LOOK AT THE TECHNOLOGY

Swivel Cap Minimizes Side Load Contidions

Sealband Technology Reduces Wear and Provides Lubricity

Design Complies With ASME/ ANSI B30.1 Safety Standard

Heavy Duty, Heat Treated Piston Rod for the Most Demanding Applications

High Pressure 3/8" NPTF Coupler

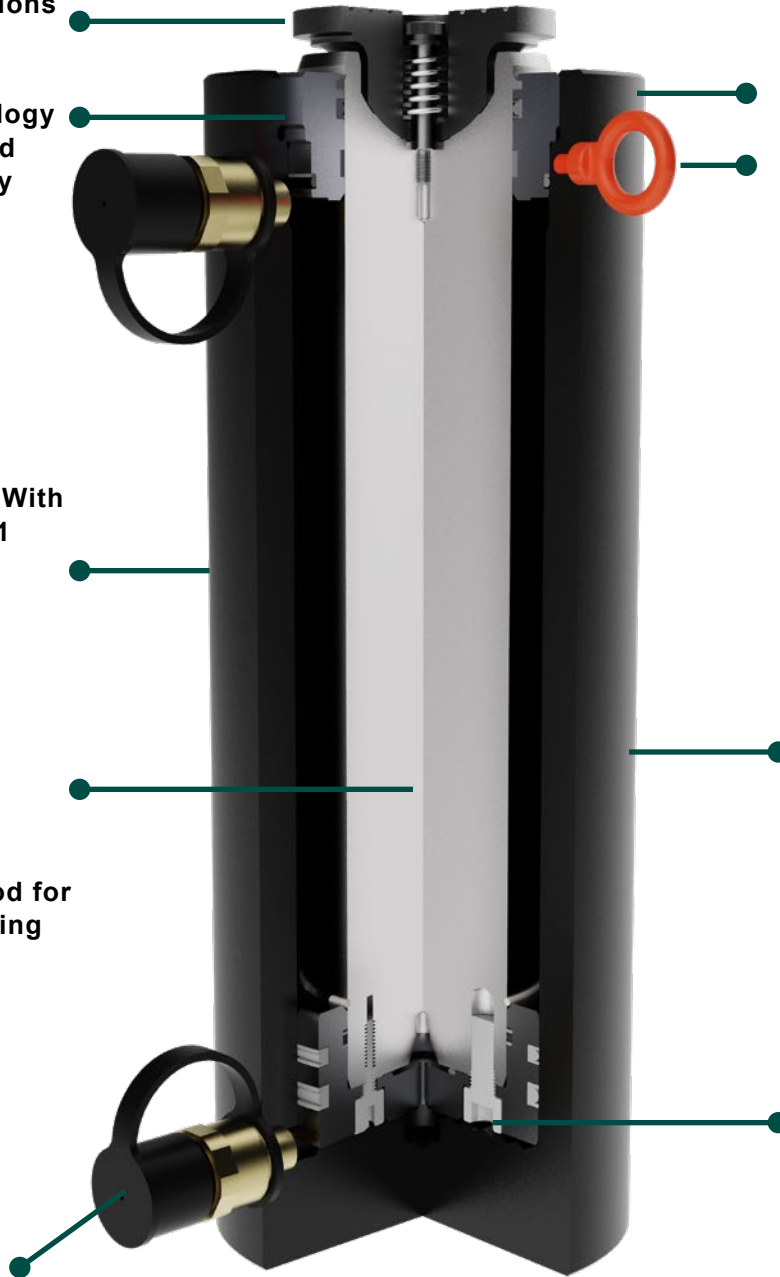

Robust Retaining Ring Withstands Full Load End Stop

Threaded Eyelets for 55-200T (Carry Straps Provided for 250-600T Cylinders)

Power-Tech Surface Treatment Provides Extended Durability

Self Aligning Piston Gland Design Resists Side Loading

RGG SERIES

Model shown: RGG552



Single Acting, load return cylinders Tonnage Range: 55–200

- **Patented swivel cap** provides concentrated load centering up to 5 degrees
- **Sealing technology** provides rod lubrication to reduce friction and wear
- **Optimized piston gland design** resists side loading conditions
- **Robust retaining ring** withstands full load end stop and conforms with ANSI B30.1 standards
- **Power-Tech nitrocarburization surface treatment** inhibits corrosion and provides exceptional durability

NOTICE: When selecting a hydraulic cylinder(s) capacity and stroke, Power Team recommends that you size to 80% of the maximum rated capacity and stroke for the application — known as the “80% Rule”. This will ensure additional safety factor and extend the product performance over time.

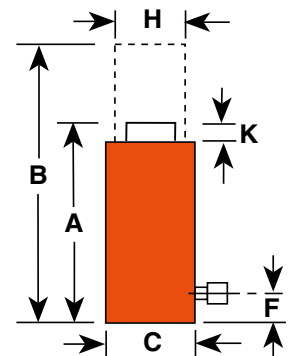

Technical dimensions

TONNAGE	55	75	100	150	200
# OF BASE MOUNTING HOLES	4	4	4	4	4
BASE THREAD SIZE	M12X1.75 – 6H	M12X1.75 – 6H	M16X1.5 – 6H	M16X1.5 – 6H	M20X1.5 – 6H
BASE THREAD DEPTH (IN)	0.709	0.709	0.62	0.9	1.2
BASE MOUNTING DIAMETER (IN.)	3.03	3.66	4.00	5.12	5.72
ORIENTATION	Mounting hole orientation is not maintained to port location.				

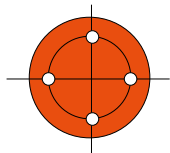

Four base mounting holes are 45° apart, standard on all models.

Ordering information: RGG Series 55-200 Tons

Tons	Stroke	Order No.	A	B	C	F	H	K	Swvl Cap Dia.	Bore Dia.	Cyl. Eff. Area (Adv.)	OIL CAP.	Internal Press At Cap.	Weight w/o Oil
			Ret. Height	Ext. Height	Out. Dia.	Base to Port	Piston Rod Dia.	Swvl Cap Pro.						
(US TONS)	(IN.)		(IN.)	(IN.)	(IN.)	(IN.)	(IN.)	(IN.)	(IN.)	(IN.)	(SQ. IN.)	(CU. IN.)	(PSI)	(LBS.)
55	2	RGG552	7.12	9.12	5.16	0.87	2.75	0.69	2.78	3.75	11.04	22.09	9960	34.6
	4	RGG554	9.12	13.12	5.16	0.87	2.75	0.69	2.78	3.75	11.04	44.18	9960	43.6
	6	RGG556	11.12	17.12	5.16	0.87	2.75	0.69	2.78	3.75	11.04	66.27	9960	52.5
	8	RGG558	13.12	21.12	5.16	0.87	2.75	0.69	2.78	3.75	11.04	88.35	9960	61.5
	10	RGG5510	15.12	25.12	5.16	0.87	2.75	0.69	2.78	3.75	11.04	110.44	9960	70.5
	12	RGG5512	17.12	29.12	5.16	0.87	2.75	0.69	2.78	3.75	11.04	132.53	9960	79.4
	13	RGG5513	18.12	31.12	5.16	0.87	2.75	0.69	2.78	3.75	11.04	143.58	9960	83.9
	14	RGG5514	19.12	33.12	5.16	0.87	2.75	0.69	2.78	3.75	11.04	154.62	9960	88.4
75	2	RGG752	7.44	9.44	5.78	0.90	3.13	0.76	3.24	4.38	15.03	30.07	9978	45.0
	4	RGG754	9.44	13.44	5.78	0.90	3.13	0.76	3.24	4.38	15.03	60.13	9978	55.7
	6	RGG756	11.44	17.44	5.78	0.90	3.13	0.76	3.24	4.38	15.03	90.20	9978	66.4
	8	RGG758	13.44	21.44	5.78	0.90	3.13	0.76	3.24	4.38	15.03	120.26	9978	77.1
	10	RGG7510	15.44	25.44	5.78	0.90	3.13	0.76	3.24	4.38	15.03	150.33	9978	87.9
	12	RGG7512	17.44	29.44	5.78	0.90	3.13	0.76	3.24	4.38	15.03	180.39	9978	98.6
	13	RGG7513	18.44	31.44	5.78	0.90	3.13	0.76	3.24	4.38	15.03	195.42	9978	104.0
	14	RGG7514	19.44	33.44	5.78	0.90	3.13	0.76	3.24	4.38	15.03	210.46	9978	109.3
100	2	RGG1002	7.79	9.79	6.53	0.94	3.75	0.92	3.87	5.13	20.63	41.26	9695	59.2
	4	RGG1004	9.79	13.79	6.53	0.94	3.75	0.92	3.87	5.13	20.63	82.51	9695	72.7
	6	RGG1006	11.79	17.79	6.53	0.94	3.75	0.92	3.87	5.13	20.63	123.77	9695	86.2
	8	RGG1008	13.79	21.79	6.53	0.94	3.75	0.92	3.87	5.13	20.63	165.03	9695	99.8
	10	RGG10010	15.79	25.79	6.53	0.94	3.75	0.92	3.87	5.13	20.63	206.28	9695	113.3
	12	RGG10012	17.79	29.79	6.53	0.94	3.75	0.92	3.87	5.13	20.63	247.54	9695	126.8
	13	RGG10013	18.79	31.79	6.53	0.94	3.75	0.92	3.87	5.13	20.63	268.17	9695	133.6
	14	RGG10014	19.79	33.79	6.53	0.94	3.75	0.92	3.87	5.13	20.63	288.80	9695	140.3
150	2	RGG1502	8.45	10.45	7.75	1.23	4.50	0.91	4.63	6.25	30.68	61.36	9779	91.3
	4	RGG1504	10.45	14.45	7.75	1.23	4.50	0.91	4.63	6.25	30.68	122.71	9779	109.6
	6	RGG1506	12.45	18.45	7.75	1.23	4.50	0.91	4.63	6.25	30.68	184.07	9779	128.0
	8	RGG1508	14.45	22.45	7.75	1.23	4.50	0.91	4.63	6.25	30.68	245.43	9779	146.4
	10	RGG15010	16.45	26.45	7.75	1.23	4.50	0.91	4.63	6.25	30.68	306.79	9779	164.7
	12	RGG15012	18.45	30.45	7.75	1.23	4.50	0.91	4.63	6.25	30.68	368.14	9779	183.1
	13	RGG15013	19.45	32.45	7.75	1.23	4.50	0.91	4.63	6.25	30.68	398.82	9779	192.3
	14	RGG15014	20.45	34.45	7.75	1.23	4.50	0.91	4.63	6.25	30.68	429.50	9779	201.4
200	2	RGG2002	9.26	11.26	9.00	1.49	5.25	1.03	5.37	7.25	41.28	82.56	9690	136.1
	4	RGG2004	11.26	15.26	9.00	1.49	5.25	1.03	5.37	7.25	41.28	165.13	9690	161.0
	6	RGG2006	13.26	19.26	9.00	1.49	5.25	1.03	5.37	7.25	41.28	247.69	9690	185.9
	8	RGG2008	15.26	23.26	9.00	1.49	5.25	1.03	5.37	7.25	41.28	330.25	9690	210.9
	10	RGG20010	17.26	27.26	9.00	1.49	5.25	1.03	5.37	7.25	41.28	412.81	9690	235.8
	12	RGG20012	19.26	31.26	9.00	1.49	5.25	1.03	5.37	7.25	41.28	495.38	9690	260.7
	13	RGG20013	20.26	33.26	9.00	1.49	5.25	1.03	5.37	7.25	41.28	536.66	9690	273.2
	14	RGG20014	21.26	35.26	9.00	1.49	5.25	1.03	5.37	7.25	41.28	577.94	9690	285.6

RGG SERIES

Models shown: RGG2502, RGG5004



Single Acting, load return cylinders Tonnage Range: 250–600

- **Patented swivel cap** provides concentrated load centering up to 5 degrees
- **Sealing technology** provides rod lubrication to reduce friction and wear
- **Optimized piston gland design** resists side loading conditions
- **Robust retaining ring** withstands full load end stop and conforms with ANSI B30.1 standards
- **Power-Tech nitrocarburization surface treatment** inhibits corrosion and provides exceptional durability

NOTICE: When selecting a hydraulic cylinder(s) capacity and stroke, Power Team recommends that you size to 80% of the maximum rated capacity and stroke for the application — known as the “80% Rule”. This will ensure additional safety factor and extend the product performance over time.

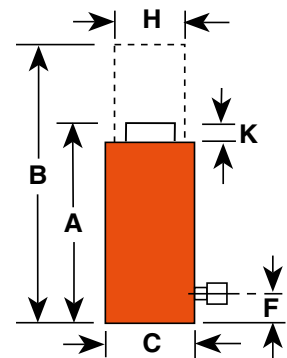

Technical dimensions

TONNAGE	250	300	400	500	600
# OF BASE MOUNTING HOLES	4	4	4	4	4
BASE THREAD SIZE	M24X3.0 – 6H	M24X3.0 – 6H	M30X3.5 – 6H	M30X3.5 – 6H	M33X2.0 – 6H
BASE THREAD DEPTH (IN)	1.457	1.457	1.8	1.5	1.95
BASE MOUNTING DIAMETER (IN.)	6.06	7.06	7.65	8.95	9.65
ORIENTATION	Mounting hole orientation is not maintained to port location.				

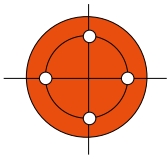

Four base mounting holes are 45° apart, standard on all models.

Ordering information: RGG Series 250-600 Tons

Tons	Stroke	Order No.	A	B	C	F	H	K	swvl cap dia.	Bore Dia.	Cyl. Eff. Area (Adv.)	Oil Cap.	Internal Press at Cap.	Wt. w/o Oil
			Ret. Height	Ext. Height	Out. Dia.	Base to Port	Piston Rod Dia.	Swvl Cap Pro.						
(US TONS)	(IN.)		(IN.)	(IN.)	(IN.)	(IN.)	(IN.)	(IN.)	(IN.)	(IN.)	(SQ. IN.)	(CU. IN.)	(PSI)	(LBS.)
250	2	RGG2502	10.30	12.30	10.10	2.35	6.00	1.12	5.56	8.00	50.26	100.53	9,947	202.4
	4	RGG2504	12.30	16.30	10.10	2.35	6.00	1.12	5.56	8.00	50.26	201.06	9,947	235.4
	6	RGG2506	14.30	20.30	10.10	2.35	6.00	1.12	5.56	8.00	50.26	301.58	9,947	268.3
	8	RGG2508	16.30	24.30	10.10	2.35	6.00	1.12	5.56	8.00	50.26	402.11	9,947	301.3
	10	RGG25010	18.30	28.30	10.10	2.35	6.00	1.12	5.56	8.00	50.26	502.64	9,947	334.2
	12	RGG25012	20.30	32.30	10.10	2.35	6.00	1.12	5.56	8.00	50.26	603.17	9,947	367.2
	13	RGG25013	21.30	34.30	10.10	2.35	6.00	1.12	5.56	8.00	50.26	653.43	9,947	383.6
	14	RGG25014	22.30	36.30	10.10	2.35	6.00	1.12	5.56	8.00	50.26	703.70	9,947	400.1
300	2	RGG3002	10.74	12.74	11.40	2.48	6.50	1.28	6.66	9.00	63.62	127.23	9,432	266.5
	4	RGG3004	12.74	16.74	11.40	2.48	6.50	1.28	6.66	9.00	63.62	254.46	9,432	307.1
	6	RGG3006	14.74	20.74	11.40	2.48	6.50	1.28	6.66	9.00	63.62	381.69	9,432	347.7
	8	RGG3008	16.74	24.74	11.40	2.48	6.50	1.28	6.66	9.00	63.62	508.92	9,432	388.3
	10	RGG30010	18.74	28.74	11.40	2.48	6.50	1.28	6.66	9.00	63.62	636.15	9,432	428.9
	12	RGG30012	20.74	32.74	11.40	2.48	6.50	1.28	6.66	9.00	63.62	763.38	9,432	469.5
	13	RGG30013	21.74	34.74	11.40	2.48	6.50	1.28	6.66	9.00	63.62	827.00	9,432	489.9
	14	RGG30014	22.74	36.74	11.40	2.48	6.50	1.28	6.66	9.00	63.62	890.62	9,432	510.2
400	2	RGG4002	12.06	14.06	13.30	2.77	7.50	1.44	7.77	10.50	86.60	173.21	9,237	413.7
	4	RGG4004	14.06	18.06	13.30	2.77	7.50	1.44	7.77	10.50	86.60	346.42	9,237	468.4
	6	RGG4006	16.06	22.06	13.30	2.77	7.50	1.44	7.77	10.50	86.60	519.62	9,237	523.1
	8	RGG4008	18.06	26.06	13.30	2.77	7.50	1.44	7.77	10.50	86.60	692.83	9,237	577.8
	10	RGG40010	20.06	30.06	13.30	2.77	7.50	1.44	7.77	10.50	86.60	866.04	9,237	632.6
	12	RGG40012	22.06	34.06	13.30	2.77	7.50	1.44	7.77	10.50	86.60	1,039.25	9,237	687.3
	13	RGG40013	23.06	36.06	13.30	2.77	7.50	1.44	7.77	10.50	86.60	1,125.85	9,237	714.6
	14	RGG40014	24.06	38.06	13.30	2.77	7.50	1.44	7.77	10.50	86.60	1,212.46	9,237	742.0
500	2	RGG5002	12.28	14.28	14.75	2.90	8.00	1.55	8.51	11.50	103.87	207.73	9,628	512.7
	4	RGG5004	14.28	18.28	14.75	2.90	8.00	1.55	8.51	11.50	103.87	415.46	9,628	579.2
	6	RGG5006	16.28	22.28	14.75	2.90	8.00	1.55	8.51	11.50	103.87	623.20	9,628	645.7
	8	RGG5008	18.28	26.28	14.75	2.90	8.00	1.55	8.51	11.50	103.87	830.93	9,628	712.2
	10	RGG50010	20.28	30.28	14.75	2.90	8.00	1.55	8.51	11.50	103.87	1,038.66	9,628	778.7
	12	RGG50012	22.28	34.28	14.75	2.90	8.00	1.55	8.51	11.50	103.87	1,246.39	9,628	845.1
	13	RGG50013	23.28	36.28	14.75	2.90	8.00	1.55	8.51	11.50	103.87	1,350.26	9,628	878.4
	14	RGG50014	24.28	38.28	14.75	2.90	8.00	1.55	8.51	11.50	103.87	1,454.12	9,628	911.6
600	2	RGG6002	12.75	14.75	16.00	3.02	9.00	1.62	9.25	12.50	122.71	245.43	9,779	609.3
	4	RGG6004	14.75	18.75	16.00	3.02	9.00	1.62	9.25	12.50	122.71	490.86	9,779	689.7
	6	RGG6006	16.75	22.75	16.00	3.02	9.00	1.62	9.25	12.50	122.71	736.29	9,779	770.2
	8	RGG6008	18.75	26.75	16.00	3.02	9.00	1.62	9.25	12.50	122.71	981.72	9,779	850.7
	10	RGG60010	20.75	30.75	16.00	3.02	9.00	1.62	9.25	12.50	122.71	1,227.15	9,779	931.2
	12	RGG60012	22.75	34.75	16.00	3.02	9.00	1.62	9.25	12.50	122.71	1,472.58	9,779	1,011.7
	13	RGG60013	23.75	36.75	16.00	3.02	9.00	1.62	9.25	12.50	122.71	1,595.29	9,779	1,051.9
	14	RGG60014	24.75	38.75	16.00	3.02	9.00	1.62	9.25	12.50	122.71	1,718.01	9,779	1,092.2

RDG SERIES

Model shown: RDG556



Double Acting, Hydraulic Return Tonnage Range: 55–200

- **Patented swivel cap** provides concentrated load centering up to 5 degrees
- **Sealing technology** provides rod lubrication to reduce friction and wear
- **Optimized piston gland design** resists side loading conditions
- **Robust retaining ring** withstands full load end stop and conforms with ANSI B30.1 standards
- **Power-Tech nitrocarburization surface treatment** inhibits corrosion and provides exceptional durability
- **Safety relief valve** prevents over-pressurization of the retract circuit

NOTICE: When selecting a hydraulic cylinder(s) capacity and stroke, Power Team recommends that you size to 80% of the maximum rated capacity and stroke for the application — known as the “80% Rule”. This will ensure additional safety factor and extend the product performance over time.

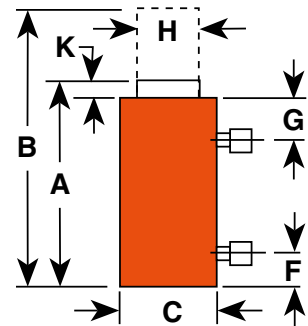

Technical dimensions

TONNAGE	55	75	100	150	200
# OF BASE MOUNTING HOLES	4	4	4	4	4
BASE THREAD SIZE	M12X1.75 – 6H	M12X1.75 – 6H	M16X1.5 – 6H	M16X1.5 – 6H	M20X1.5 – 6H
BASE THREAD DEPTH (IN)	0.709	0.709	0.62	0.9	1.2
BASE MOUNTING DIAMETER (IN.)	3.03	3.66	4.00	5.12	5.72
ORIENTATION	Mounting hole orientation is not maintained to port location.				

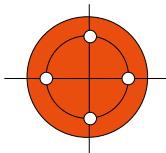

Four base mounting holes are 45° apart, standard on all models.

Ordering information: RDG Series 55-200 Tons

TONS	Stroke	Order No.	A	B	C	F	G	H	K	swvl cap dia.	Bore Dia.	Cyl. Eff. Area (Adv.)	Oil Cap.	Int. Press at Cap.	Wt. w/o Oil
			Ret. Height	Ext. Height	Out. Dia.	Base to Port	top to Port	Piston Rod Dia.	Swvl Cap Pro.						
(US TONS)	(IN.)		(IN.)	(IN.)	(IN.)	(IN.)	(IN.)	(IN.)	(IN.)	(IN.)	(IN.)	(SQ.IN.)	(CU.IN.)	(PSI)	(LBS.)
55	2	RDG552	7.12	9.12	5.16	0.87	1.61	2.75	0.69	2.78	3.75	11.04	22.09	9,960	35.0
	4	RDG554	9.12	13.12	5.16	0.87	1.61	2.75	0.69	2.78	3.75	11.04	44.18	9,960	44.0
	6	RDG556	11.12	17.12	5.16	0.87	1.61	2.75	0.69	2.78	3.75	11.04	66.27	9,960	52.9
	8	RDG558	13.12	21.12	5.16	0.87	1.61	2.75	0.69	2.78	3.75	11.04	88.35	9,960	61.9
	10	RDG5510	15.12	25.12	5.16	0.87	1.61	2.75	0.69	2.78	3.75	11.04	110.44	9,960	70.8
	12	RDG5512	17.12	29.12	5.16	0.87	1.61	2.75	0.69	2.78	3.75	11.04	132.53	9,960	79.8
	14	RDG5514	19.12	33.12	5.16	0.87	1.61	2.75	0.69	2.78	3.75	11.04	154.62	9,960	88.8
75	2	RDG752	7.44	9.44	5.78	0.90	1.76	3.13	0.76	3.24	4.38	15.03	30.07	9,978	45.4
	4	RDG754	9.44	13.44	5.78	0.90	1.76	3.13	0.76	3.24	4.38	15.03	60.13	9,978	56.1
	6	RDG756	11.44	17.44	5.78	0.90	1.76	3.13	0.76	3.24	4.38	15.03	90.20	9,978	66.8
	8	RDG758	13.44	21.44	5.78	0.90	1.76	3.13	0.76	3.24	4.38	15.03	120.26	9,978	77.5
	10	RDG7510	15.44	25.44	5.78	0.90	1.76	3.13	0.76	3.24	4.38	15.03	150.33	9,978	88.3
	12	RDG7512	17.44	29.44	5.78	0.90	1.76	3.13	0.76	3.24	4.38	15.03	180.39	9,978	99.0
	14	RDG7514	19.44	33.44	5.78	0.90	1.76	3.13	0.76	3.24	4.38	15.03	210.46	9,978	109.7
100	2	RDG1002	7.79	9.79	6.53	0.94	1.85	3.75	0.92	3.87	5.13	20.63	41.26	9,695	59.3
	4	RDG1004	9.79	13.79	6.53	0.94	1.85	3.75	0.92	3.87	5.13	20.63	82.51	9,695	72.9
	6	RDG1006	11.79	17.79	6.53	0.94	1.85	3.75	0.92	3.87	5.13	20.63	123.77	9,695	86.4
	8	RDG1008	13.79	21.79	6.53	0.94	1.85	3.75	0.92	3.87	5.13	20.63	165.03	9,695	99.9
	10	RDG10010	15.79	25.79	6.53	0.94	1.85	3.75	0.92	3.87	5.13	20.63	206.28	9,695	113.4
	12	RDG10012	17.79	29.79	6.53	0.94	1.85	3.75	0.92	3.87	5.13	20.63	247.54	9,695	126.9
	14	RDG10014	19.79	33.79	6.53	0.94	1.85	3.75	0.92	3.87	5.13	20.63	288.80	9,695	140.5
150	2	RDG1502	8.45	10.45	7.75	1.23	2.11	4.50	0.91	4.63	6.25	30.68	61.36	9,779	91.4
	4	RDG1504	10.45	14.45	7.75	1.23	2.11	4.50	0.91	4.63	6.25	30.68	122.71	9,779	109.8
	6	RDG1506	12.45	18.45	7.75	1.23	2.11	4.50	0.91	4.63	6.25	30.68	184.07	9,779	128.1
	8	RDG1508	14.45	22.45	7.75	1.23	2.11	4.50	0.91	4.63	6.25	30.68	245.43	9,779	146.5
	10	RDG15010	16.45	26.45	7.75	1.23	2.11	4.50	0.91	4.63	6.25	30.68	306.79	9,779	164.9
	12	RDG15012	18.45	30.45	7.75	1.23	2.11	4.50	0.91	4.63	6.25	30.68	368.14	9,779	183.2
	14	RDG15014	20.45	34.45	7.75	1.23	2.11	4.50	0.91	4.63	6.25	30.68	429.50	9,779	201.6
200	2	RDG2002	9.26	11.26	9.00	1.49	2.25	5.25	1.03	5.37	7.25	41.28	82.56	9,690	136.3
	4	RDG2004	11.26	15.26	9.00	1.49	2.25	5.25	1.03	5.37	7.25	41.28	165.13	9,690	161.2
	6	RDG2006	13.26	19.26	9.00	1.49	2.25	5.25	1.03	5.37	7.25	41.28	247.69	9,690	186.1
	8	RDG2008	15.26	23.26	9.00	1.49	2.25	5.25	1.03	5.37	7.25	41.28	330.25	9,690	211.0
	10	RDG20010	17.26	27.26	9.00	1.49	2.25	5.25	1.03	5.37	7.25	41.28	412.81	9,690	236.0
	12	RDG20012	19.26	31.26	9.00	1.49	2.25	5.25	1.03	5.37	7.25	41.28	495.38	9,690	260.9
	14	RDG20014	21.26	35.26	9.00	1.49	2.25	5.25	1.03	5.37	7.25	41.28	577.94	9,690	285.8

RDG SERIES

Models shown: RDG2502, RDG6004



Single Acting, load return cylinders Tonnage Range: 250-600

- **Patented swivel cap** provides concentrated load centering up to 5 degrees
- **Sealing technology** provides rod lubrication to reduce friction and wear
- **Optimized piston gland design** resists side loading conditions
- **Robust retaining ring** withstands full load end stop and conforms with ANSI B30.1 standards
- **Power-Tech nitrocarburization surface treatment** inhibits corrosion and provides exceptional durability
- **Safety relief valve** prevents over-pressurization of the retract circuit

NOTICE: When selecting a hydraulic cylinder(s) capacity and stroke, Power Team recommends that you size to 80% of the maximum rated capacity and stroke for the application — known as the “80% Rule”. This will ensure additional safety factor and extend the product performance over time.

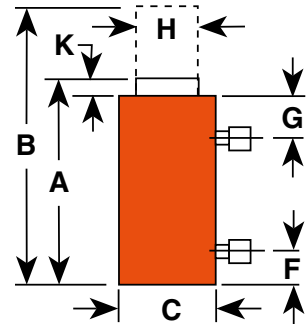

Technical dimensions

TONNAGE	250	300	400	500	600
# OF BASE MOUNTING HOLES	4	4	4	4	4
BASE THREAD SIZE	M24X3.0 – 6H	M24X3.0 – 6H	M30X3.5 – 6H	M30X3.5 – 6H	M33X2.0 – 6H
BASE THREAD DEPTH (IN)	1.457	1.457	1.8	1.5	1.95
BASE MOUNTING DIAMETER (IN.)	6.06	7.06	7.65	8.95	9.65
ORIENTATION	Mounting hole orientation is not maintained to port location.				

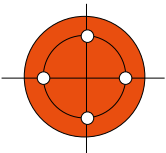

Four base mounting holes are 45° apart, standard on all models.

Ordering information: RDG Series 250-600 Tons

Tons	Stroke	Order No.	A	B	C	F	G	H	K	swvl cap dia.	Bore Dia.	Cyl. Eff. Area (Adv.)	Oil Cap.	Int. Press at Cap.	Wt. w/o Oil
			Ret. Height	Ext. Height	Out. Dia.	Base to Port	top to Port	Piston Rod Dia.	Swvl Cap Pro.						
(US TONS)	(IN.)		(IN.)	(IN.)	(IN.)	(IN.)	(IN.)	(IN.)	(IN.)	(IN.)	(IN.)	(IN ²)	(IN ³)	(PSI)	(LBS.)
250	2	RDG2502	10.30	12.30	10.10	2.35	2.35	6.00	1.12	5.56	8.00	50.26	100.53	9,947	202.6
	4	RDG2504	12.30	16.30	10.10	2.35	2.35	6.00	1.12	5.56	8.00	50.26	201.06	9,947	235.6
	6	RDG2506	14.30	20.30	10.10	2.35	2.35	6.00	1.12	5.56	8.00	50.26	301.58	9,947	268.5
	8	RDG2508	16.30	24.30	10.10	2.35	2.35	6.00	1.12	5.56	8.00	50.26	402.11	9,947	301.5
	10	RDG25010	18.30	28.30	10.10	2.35	2.35	6.00	1.12	5.56	8.00	50.26	502.64	9,947	334.4
	12	RDG25012	20.30	32.30	10.10	2.35	2.35	6.00	1.12	5.56	8.00	50.26	603.17	9,947	367.3
	13	RDG25013	21.30	34.30	10.10	2.35	2.35	6.00	1.12	5.56	8.00	50.26	653.43	9,947	383.8
	14	RDG25014	22.30	36.30	10.10	2.35	2.35	6.00	1.12	5.56	8.00	50.26	703.70	9,947	400.3
300	2	RDG3002	10.74	12.74	11.40	2.48	2.48	6.50	1.28	6.66	9.00	63.62	127.23	9,432	266.7
	4	RDG3004	12.74	16.74	11.40	2.48	2.48	6.50	1.28	6.66	9.00	63.62	254.46	9,432	307.3
	6	RDG3006	14.74	20.74	11.40	2.48	2.48	6.50	1.28	6.66	9.00	63.62	381.69	9,432	347.9
	8	RDG3008	16.74	24.74	11.40	2.48	2.48	6.50	1.28	6.66	9.00	63.62	508.92	9,432	388.5
	10	RDG30010	18.74	28.74	11.40	2.48	2.48	6.50	1.28	6.66	9.00	63.62	636.15	9,432	429.1
	12	RDG30012	20.74	32.74	11.40	2.48	2.48	6.50	1.28	6.66	9.00	63.62	763.38	9,432	469.7
	13	RDG30013	21.74	34.74	11.40	2.48	2.48	6.50	1.28	6.66	9.00	63.62	827.00	9,432	490.0
	14	RDG30014	22.74	36.74	11.40	2.48	2.48	6.50	1.28	6.66	9.00	63.62	890.62	9,432	510.3
400	2	RDG4002	12.06	14.06	13.30	2.77	2.77	7.50	1.44	7.77	10.50	86.60	173.21	9,237	413.9
	4	RDG4004	14.06	18.06	13.30	2.77	2.77	7.50	1.44	7.77	10.50	86.60	346.42	9,237	468.6
	6	RDG4006	16.06	22.06	13.30	2.77	2.77	7.50	1.44	7.77	10.50	86.60	519.62	9,237	523.3
	8	RDG4008	18.06	26.06	13.30	2.77	2.77	7.50	1.44	7.77	10.50	86.60	692.83	9,237	578.0
	10	RDG40010	20.06	30.06	13.30	2.77	2.77	7.50	1.44	7.77	10.50	86.60	866.04	9,237	632.7
	12	RDG40012	22.06	34.06	13.30	2.77	2.77	7.50	1.44	7.77	10.50	86.60	1039.25	9,237	687.5
	13	RDG40013	23.06	36.06	13.30	2.77	2.77	7.50	1.44	7.77	10.50	86.60	1125.85	9,237	714.8
	14	RDG40014	24.06	38.06	13.30	2.77	2.77	7.50	1.44	7.77	10.50	86.60	1212.46	9,237	742.2
500	2	RDG5002	12.28	14.28	14.75	2.90	2.90	8.00	1.55	8.51	11.50	103.87	207.73	9,628	512.9
	4	RDG5004	14.28	18.28	14.75	2.90	2.90	8.00	1.55	8.51	11.50	103.87	415.46	9,628	579.4
	6	RDG5006	16.28	22.28	14.75	2.90	2.90	8.00	1.55	8.51	11.50	103.87	623.20	9,628	645.9
	8	RDG5008	18.28	26.28	14.75	2.90	2.90	8.00	1.55	8.51	11.50	103.87	830.93	9,628	712.4
	10	RDG50010	20.28	30.28	14.75	2.90	2.90	8.00	1.55	8.51	11.50	103.87	1038.66	9,628	778.9
	12	RDG50012	22.28	34.28	14.75	2.90	2.90	8.00	1.55	8.51	11.50	103.87	1246.39	9,628	845.3
	13	RDG50013	23.28	36.28	14.75	2.90	2.90	8.00	1.55	8.51	11.50	103.87	1350.26	9,628	878.6
	14	RDG50014	24.28	38.28	14.75	2.90	2.90	8.00	1.55	8.51	11.50	103.87	1454.12	9,628	911.8
600	2	RDG6002	12.75	14.75	16.00	3.02	3.02	9.00	1.62	9.25	12.50	122.71	245.43	9,779	609.5
	4	RDG6004	14.75	18.75	16.00	3.02	3.02	9.00	1.62	9.25	12.50	122.71	490.86	9,779	690.0
	6	RDG6006	16.75	22.75	16.00	3.02	3.02	9.00	1.62	9.25	12.50	122.71	736.29	9,779	770.5
	8	RDG6008	18.75	26.75	16.00	3.02	3.02	9.00	1.62	9.25	12.50	122.71	981.72	9,779	850.9
	10	RDG60010	20.75	30.75	16.00	3.02	3.02	9.00	1.62	9.25	12.50	122.71	1227.15	9,779	931.4
	12	RDG60012	22.75	34.75	16.00	3.02	3.02	9.00	1.62	9.25	12.50	122.71	1472.58	9,779	1,011.9
	13	RDG60013	23.75	36.75	16.00	3.02	3.02	9.00	1.62	9.25	12.50	122.71	1595.29	9,779	1,052.1
	14	RDG60014	24.75	38.75	16.00	3.02	3.02	9.00	1.62	9.25	12.50	122.71	1718.01	9,779	1,092.4

Custom stroke lengths are available, contact your local Power Team Sales Office for details and availability.



SPX FLOW, Inc. reserves the right to incorporate our latest design and material changes without notice or obligation. Design features, materials of construction and dimensional data, as described in this bulletin, are provided for your information only and should not be relied upon unless confirmed in writing. Please contact your local sales representative for product availability in your region. The green "➤" is a trademark of SPX FLOW, Inc.

For more information, visit www.spxflow.com/powerteam

P: (800) 541-1418 • E: info@powerteam.com | 5885 11th Street • Rockford, IL 61109 U.S.A

PT_RGG_RDG_US | VERSION 04/2022 | COPYRIGHT © 2022 SPX FLOW, Inc.