

APV BLV1

球阀

文件编号: H342505

版本: CN-2

在操作或维护本产品之前，请阅读并理解本说明书。



欧盟关于阀门和阀阵的符合性声明

SPX Flow Technology Germany GmbH
Gottlieb-Daimler-Str. 13, D-59439 Holzwickede
特此声明

**SD4、SDT4、SDU4、SDMS4、SDMSU4、SDTMS4、SWcip4、DSV、
DA4、D4 SL、D4、DA3、DA3SLD、DE3、DEU3、DET3、DKR2、DKRT2、
DKRH2系列APV双密封阀和双座阀**
公称直径DN 25 - 150、ISO 1" - 6" 和1 Sh5 - 6 Sh5

SV1和SVS1F、SV2和SV2F、SVL和SVSL系列APV蝶阀
公称直径DN 25 - 100、DN 125 - 250和ISO 1" - 4"

KHI、KHV、BLV1系列APV球阀
公称直径DN 15 - 100、ISO 1/2"-4"

**S2、SW4、SWhp4、SW4DPF、SWmini4、SWT4、SWS4、MF4、MS4、MSP4、
AP/T1、CPV、RG4、RG4DPF、RGMS4、RGE4、RGE4DPF、RGEMS4、PR2、PRD2、
SI2、UF/R3、VRA/H系列APV单座阀、弹簧式隔膜阀**
公称直径DN 10 - 150、ISO 1/2" - 4" 和1 Sh5 - 6 Sh5

以及由上述阀门制成的阀阵

符合指令2006/42/EC（替代89/392/EEC或98/37/EC）以及ProdSG
（替代GPSG - 9.GPSGV）的要求。

SPX FLOW依照机械指令附录VII，提供相应的监管控制技术文件，包括设计和结构文件，其中说明了为确保遵守并符合基本健康和国家安全要求（包括风险分析）所应采取的措施，包括风险分析，以及包含安全说明的使用说明书。

特此保证阀门和阀阵的合规性。

文件授权代表：
Frank Baumbach

SPX Flow Technology Germany GmbH
Gottlieb-Daimler-Str. 13, D-59439 Holzwickede, 德国

2020年1月

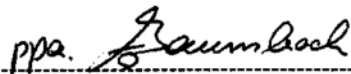

Frank Baumbach
Engineering Director – Sanitary Components

目录		页码
1.	概述	6
2.	安全	6
2.1.	符号标志	
2.2.	安全说明	
3.	预期用途	7
4.	操作	8
4.1.	概述	
5.	附加设备	9
5.1.	手动 / 控制阀门的阀门位置反馈	
5.2.	控制单元	
5.3.	用于控制单元的旋转驱动装置	
6.	清洁	10
6.1.	清洁建议	
7.	安装和调试	11
7.1.	焊接说明	
8.	尺寸 / 重量	12
8.1.	BLV1 - H – DN 15–100; ½" - 4" 手动操作不带反馈单元的球阀	
8.2.	BLV1 - HL – DN 15–100; ½" - 4" 手动操作带反馈单元的球阀	
8.3.	BLV1 - NC – DN15–100; ½" - 4" 通过旋转驱动装置 / 控制单元控制球阀	
9.	技术数据	14
9.1.	一般数据	
9.2.	压缩空气质量	
9.3.	最大扭矩	
9.4.	控制空气消耗	
10.	材料	15
11.	维护	16
12.	安装说明 BLV1 - H	17
12.1.	从管路系统上拆卸	
12.2.	更换阀球和球座	
12.3.	更换切换轴密封件	
13.	安装说明 BLV1 - HL	19
13.1.	从管路系统上拆卸	
13.2.	拆卸主控台与手杆	
14.	安装说明 BLV1 - NC	20
14.1.	从管路系统上拆卸	
14.2.	拆卸主控台与旋转驱动装置	
15.	备件清单	21
	BLV1 - HL DN 15 - DN 50 和 1/2" – 2"	RN 01.245 - 1
	BLV1 - HL DN 65 - DN 100 和 2 1/2" - 4"	RN 01.245 - 3
	BLV1 - NC DN15 - DN 100 和 1/2" – 4"	RN 01.245 - 2
	旋转驱动装置 K-080, K-125, K-180	RN 01.073
	旋转驱动装置 K-080、K-125、K-180, 用于控制单元	RN 01.076

1. 概述

操作人员和维护人员必须阅读并遵守本操作说明书。

特此声明，对于因为未遵守操作说明而导致的损坏和故障，我们概不承担任何责任。

我们保留对示图和信息进行技术更改的权利。

2. 安全

2.1 符号标志



注意！

健康和安全的标志提醒您注意有关的重要健康和安全的健康信息。您可以在对您的健康构成威胁、对人员和财产构成风险的所述作业地点取阅。



重要提示！

必要技术信息

2.2. 安全说明



严禁打开驱动装置。
存在危害健康和生命的危险！

废弃和 / 或无效的驱动装置必须加以妥善处理。

必须将有缺陷的驱动装置送回到您的 SPX FLOW 销售公司，
可以免费为您进行适当的处置。

请联系您的 SPX FLOW 销售公司。



- 切勿在处理炙热液体过程中接触球阀或管路！



- 请勿将手伸入敞开的阀球或阀箱中。
如果阀门突然切换，可能会有受伤的危险。



- 在拆卸的状态下，可能在活动的阀门部件上有挤压的危险。

2. 安全



- 在进行维护工作之前，管路和清洁系统必须卸压，如有可能，进行排空！



- 断开电气和气动连接。



- 拆卸时，阀球中仍可能残留有介质。



- 更换密封件之前，请先卸下旋转驱动装置。



- 请遵循安装说明进行安全维护。



- 应计划对阀门进行定期维护，包括更换所有密封件，以防止泄漏和介质逸出。



- 阀门仅限由经过培训的人员进行组装、操作、拆卸、维护或维修。如有必要，请联系您当地的 SPX FLOW 营业处。

3. 预期用途

球阀应用范围的预期用途是用于关闭管段。



注意！请勿擅自改动阀门，否则会影响阀门的安全性和预期功能。



注意！标准 BLV1 球阀不得用于具有潜在爆炸危险的环境中。



注意！标准 BLV1 球阀不得用于卫生用途。

SPX FLOW APV 阀门专为应用于食品和饮料、制药及化学工业而设计。

根据压力设备指令 2014/68/EU，SPX FLOW APV 阀门（不具有安全功能）属于 1 类，并根据符合性评定程序归为模式 A。

以下根据第 13 条分配适用于在阀门中处理的流体：

产品介质 – 流体组 2 – 所有公称尺寸的阀门。

CIP 清洁介质 – 流体组 1 - 公称尺寸阀门 \leq DN100/4" 可在最高 140°C 的温度下使用，公称尺寸阀门 $>$ DN100/4" 可在 100°C 的温度下使用。

3. 预期用途

许可和外部评估

如要查看此产品和其他 SPX FLOW 创新产品的认证，请访问：
<https://www.spxflow.com/en/apv/about-us/certifications/>

设备运营商有责任评估并验证 SPX FLOW 产品在预期用途和维修条件下的适用性，确定并遵循适用于预期用途和应用领域的法律。

4. 操作

4.1. 概述

光滑的阀门通道，在标称管路直径尺寸下具有完整的开口横截面。

分别有三种设计类型：

- 球阀 **BLV1-H** 标准型，配备手杆，不带反馈
- 球阀 **BLV1-HL** 配备手杆及用于反馈的主控台
- 球阀 **BLV1-NC** 可通过气动驱动装置进行控制

- **BLV1** 球阀由于使用了高质量的不锈钢和适当的密封件材料，非常适合用于食品、饮料、制药及化工行业。

注意！

由于球阀具有无法清洁的死角，因此最好不要在食品加工技术与产品接触的区域使用！

- 阀球作为关闭元件，存放在由 PTFE 合成材料制成的密封壳两侧中。阀球的浮动轴承允许在关闭位置上沿流动方向运动，从而确保通道中能有最佳密封（**B** 和 **C**）。
- 阀球的切换轴务必从内部插入。如此，大于壳体孔的凸台可防止切换轴向外推出。切换轴用填料函进行密封，并用螺纹衬套拧紧。
- 壳体和朝外对接法兰之间的密封是使用由标准规格的 PTFE 合成材料制成的壳体密封环。

注意！

球阀没有单独用来清洁现有的死角的 CIP 接口！

- 由在 **(A)** 处的空气接口通过气动旋转驱动装置执行，在弹簧力的作用下，将回到“关闭”的末端位置。

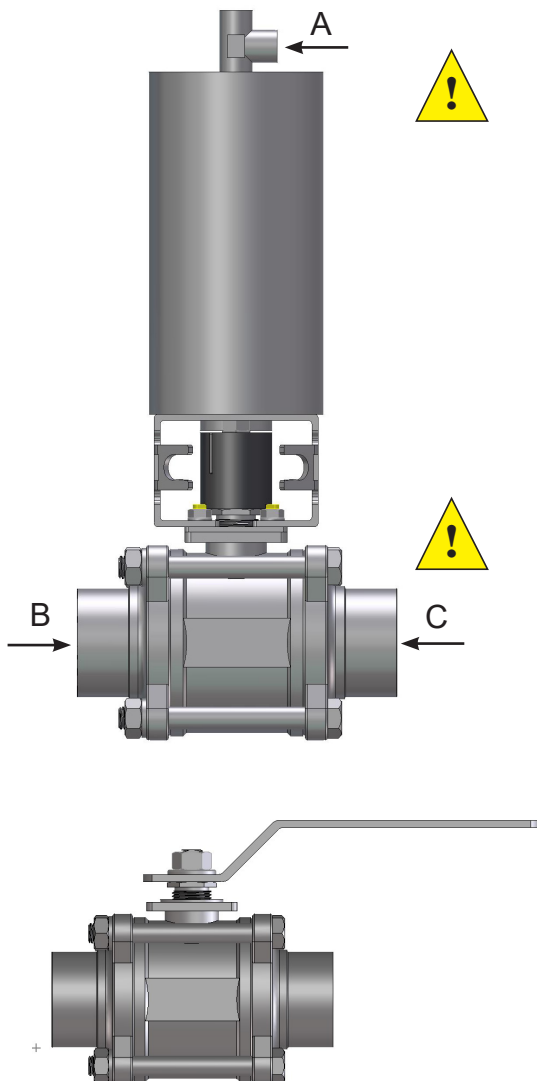

5. 附加设备

手动操作带用于球阀位置反馈阀箱的球阀

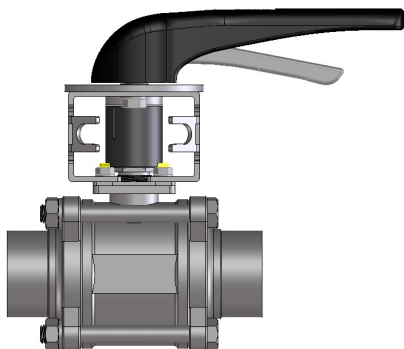

5.1. 手动 / 控制阀门的阀门位置反馈
用于指示球阀末端位置的启动器可以根据需要安装在阀箱区域上。

为此，我们推荐使用我们的 APV 标准启动器之一。
型号：三线启动器 (H340207; 000-08-60-114/93)
切换距离：5 mm/ 直径：M12/ 长度：40 mm

如果客户使用其他阀门位置指示器，那么我们无法保证可正常运作。

1 个用于球阀位置反馈的启动器已关闭或已开启。

2 个用于两个球阀位置反馈的启动器已开启并已关闭。

CU4 控制单元



5.2. 控制单元
现场总线技术中还提供了带有反馈开关和电磁阀的单元，可用于气动控制安装在旋转驱动装置上的阀门。
可以在为此准备的旋转驱动装置型号上安装控制单元。

使用相应的操作说明书，为各种规格进行调试及安装和拆卸。

可以在不同的规格之间选择：

CU4 - 直接连接 参考编号	CU41 - T - 直接连接 H320461; 000-08-45-101/93
CU4 - AS 接口 31 从站 参考编号	CU41 - T - AS-i 标准 H324674; 000-08-45-251/93
CU4 - AS 接口 62 从站 参考编号	CU41 - T - AS-i 加长 H320468; 000-08-45-111/93

5. 附加设备

- 5.3. 用于控制单元的旋转驱动装置
- 需要特殊的旋转驱动装置将控制单元安装在球阀上。

必须更换标准的旋转驱动装置。

用于控制单元的旋转驱动装置	
旋转驱动装置 K080 F/L RME für BLV1 DN 15–50; 1/2"-2"	H123937 000-15-37-070/17
旋转驱动装置 K125 F/L RME für BLV1 DN 65–80; 2 1/2"-3"	H128942 000-15-37-106/17
旋转驱动装置 K180 F/L RME, 用于 BLV1 DN 100; 4"	H134034 000-15-37-103/17

- 需要 CU 转接器将控制单元安装在特殊的旋转驱动装置上。

用于控制单元 CU4-T 的转接器	
CU4-T 转接器 DN 15–50; 1/2" – 2"	H320475 000-08-48-601/93
CU4-Tmax 转接器 DN 65 - 100; 2 1/2" - 4"	H321987 000-08-48-611/93

6. 清洁

- 6.1. 清洁建议
- 清洁连接的管路时，应用清洁介质
清洁阀门通道。

根据受到污染的程度和因素，必须为各个应用情况安排清洁介质、清洁时间及清洁流程。



注意！
所使用的清洁介质必须与相应的密封件材料相容。

7. 安装和调试

球阀的安装位置可以根据当地条件和需要执行的任务自由选择。



注意！ 请遵照焊接说明 7.1。



注意！

首次调试之前：

- 检查控制单元或阀门位置反馈的功能（如有安装）。
- 在调试期间注意可能的泄漏。更换存在缺陷的密封件。

7.1 焊接说明

- 焊接前必须取下所有敏感的组件！卸下球阀壳体，并取出在对接法兰之间的密封件。
- 仅限由经过认证的焊工（DIN EN ISO 9606-1）进行所有焊接工作（焊缝质量 DIN EN ISO 5817）。
- 对接法兰必须以不会出现变形应力的方式进行焊接。
- 必须使用 TIG 焊接程序！
- 应准备将壁厚在 3 mm 以下的焊缝钝化成无空气的 I 型接头。注意热缩尺寸！



注意！

在对接法兰焊接后或进行管路工作后，必须清洁相关的设备部件或管路上的焊接残留物和污垢。如果未遵守此清洁规定，则焊接残留物或污垢颗粒可能会积聚在阀门中并造成损坏，或者被带入系统的其他部件上。



- 对于因未遵守有关焊接说明而造成的任何损坏，均不在我们的保修范围内。

8. 尺寸 / 重量

8.1. BLV1-H - DN 15-100; 1/2"-4" 手动操作不带反馈单元的球阀

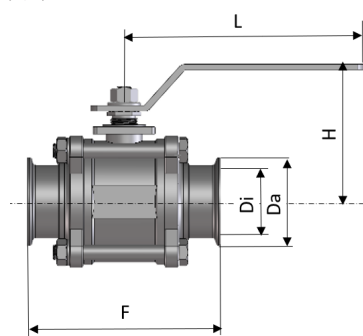
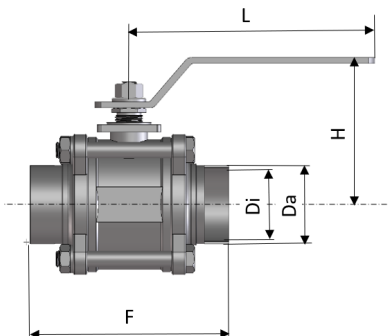

尺寸, 单位: mm						重量
DN	Di	Da	F	L	H	单位: kg
15	16	19	88	132	64	0.75
20	20	23	101	132	69	0.85
25	26	29	114	165	69	1.00
40	38	41	139	194	88	2.20
50	50	53	155	194	97	3.65
65	66	70	197	251	131	7.65
80	81	85	229	251	144	10.55
100	100	104	243	332	172	19.15

尺寸, 单位: mm						重量
DN	Di	Da	F	L	H	单位: kg
15	16	34	88	132	64	0.75
20	20	34	101	132	69	0.85
25	26	50.5	114	165	69	1.00
40	38	50.5	139	194	88	2.20
50	50	64	155	194	97	3.65
65	66	91	197	251	131	7.65
80	81	106	229	251	144	10.55
100	100	119	243	332	172	19.15

尺寸, 单位: mm						重量
英制	Di	Da	F	L	H	单位: kg
1/2"	9.4	12.7	88	132	64	0.75
3/4"	15.8	19.1	101	132	69	0.85
1"	22.2	25.4	114	165	69	1.00
1 1/2"	34.9	38.1	139	194	88	2.20
2"	47.6	50.8	155	194	97	3.65
2 1/2"	60.3	63.5	197	251	131	7.65
3"	72.9	76.1	229	251	144	10.55
4"	97.6	101.6	243	332	172	19.15

尺寸, 单位: mm						重量
英制	Di	Da	F	L	H	单位: kg
1/2"	9.4	25	88	132	64	0.75
3/4"	15.8	25	101	132	69	0.85
1"	22.2	50.5	114	165	69	1.00
1 1/2"	34.9	50.5	139	194	88	2.20
2"	47.6	64	155	194	97	3.65
2 1/2"	60.3	77.5	197	251	131	7.65
3"	72.9	91	229	251	144	10.55
4"	97.6	119	243	332	172	19.15

8.2. BLV1-HL - DN 15-100; 1/2"-4" 手动操作带反馈单元的球阀

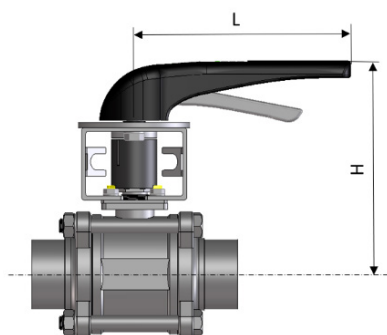

DN15 - DN50; 0.5"-2"

尺寸, 单位: mm				重量
DN	英制	H	L	单位: kg
15	1/2"	132	165	1.50
20	3/4"	137	165	1.70
25	1"	140	165	1.90
40	1 1/2"	154	165	3.00
50	2"	162	165	4.40
65	2 1/2"	234	251	9.30
80	3"	247	251	12.2
100	4"	275	332	21.0

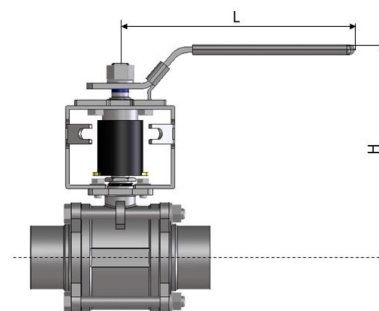

DN65 - DN100; 2.5"-4"

8. 尺寸 / 重量

8.3. BLV1-NC - DN15-100; 1/2"-4" 通过旋转驱动装置 / 控制单元控制球阀

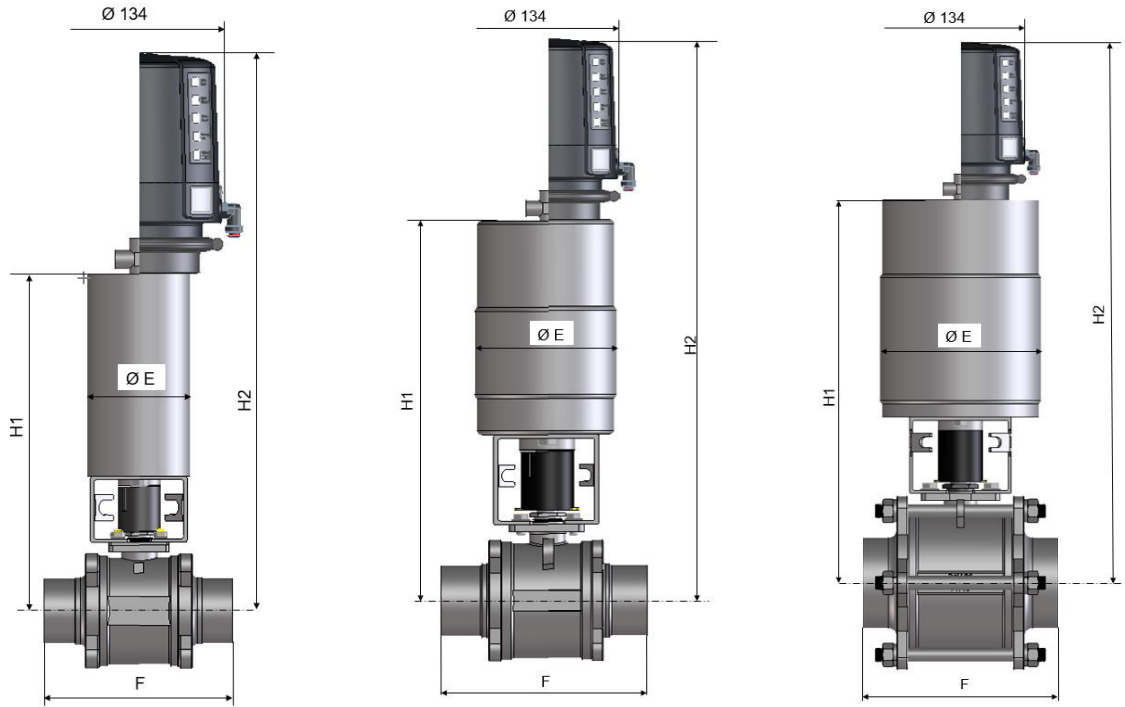

尺寸, 单位: mm						重量, 单位: kg 不带 CU	重量, 单位: kg 带 CU
DN	英制	F	E	H1	H2		
15	1/2"	88	85	250	429	3.7	4.9
20	3/4"	101	85	255	434	3.9	5.1
25	1"	114	85	258	437	4.1	5.3
40	1 1/2"	139	85	272	451	5.2	6.4
50	2"	155	85	280	459	6.6	7.8
65	2 1/2"	197	135	382	561	16.7	17.9
80	3"	229	135	392	571	19.6	20.8
100	4"	243	189	453	632	37.0	38.2

9. 技术数据

9.1. 一般数据

- 最大管路压力：

英寸	DN	最高 140°C 温度下的最大管路压力 (bar)
1/2"	15	63
3/4"	20	63
1"	25	63
1.5"	40	40
2"	50	40
2.5"	65	25
3"	80	25
4"	100	20



注意！

只使用符合设备中所使用的压力等级的 TC 接头（可能是 高压 TC 连接）！

- 最高工作温度：0–140 °C
- 短暂的蒸汽负荷：160 °C
- 旋转驱动装置
 - 最小控制压力：6 bar
 - 最大控制压力：10 bar
 - 旋转角度：90°
- 空气接口（用于软管）：6 x 1
弯头配件 – G1/8"
可旋转：拧紧力矩 2 Nm

s9.2. 压缩空气质量

- 压缩空气质量：质量等级符合 DIN ISO 8573-1
- 固体颗粒含量：质量等级 3，
每立方米最大颗粒数
0.5 μm ≤ d ≤ 1.0 μm 有 10000
1.0 μm ≤ d ≤ 5.0 μm 有 500 个
- 含水量：质量等级 3，
最高露点温度 - 20 °C
在低温下或高海拔较高的地区进行安装时，必须采取其他措施来相应降低压力露点。
- 含油量：质量等级 1，
最大 0.01 mg/m³
所使用的油品必须与聚氨酯弹性体材料相容。

所使用的油品必须与聚氨酯弹性体材料相容。

9. 技术数据

9.3. 最大扭矩 扭矩，驱动装置尺寸配置

球阀	公称尺寸							
DN	15	20	25	40	50	65	80	100
英制	1/2"	3/4"	1"	1 1/2"	2"	2 1/2"	3"	4"
旋转驱动装置	K080				K125			K180
扭矩 (Nm)	5.0	6.5	9.5	18.0	23.5	59.5	64	96
球阀	公称尺寸							
DN	15	20	25	40	50	65	80	100
英制	1/2"	3/4"	1"	1 1/2"	2"	2 1/2"	3"	4"
切换轴填料函的拧紧扭矩 (Nm)	9.0	9.0	11.0	28.0	28.0	34.0	57.0	80.0
壳体螺栓 拧紧扭矩 (Nm)	11.3	12.5	13.5	30.0	30.0	40.0	50.0	60.0

9.4. 控制空气消耗

旋转驱动装置	每冲程 控制空气消耗
K080	1.8 NI
K125	5.5 NI
K180	11 NI

10. 材料

- 阀球 1.4404 (DIN EN 10088)
- 壳体 1.4408/1.4404 (DIN EN 10088)
- 阀箱、驱动装置 1.4301 (DIN EN 10088)
- 联结器 1.4301 (DIN EN 10088)
- 指示器 PE-hart
- 阀球密封件 / 密封壳 PTFE 合成材料
- 壳体密封件 PTFE 合成材料
- 驱动装置中的塑料部件：
- 主轴轴承 Polyamid PA 12
- 空气接口 Polyamid PA 6.6
- 活塞 Polyacetal POM

11. 维护



提示！

维护间隔因使用情况而异，应由用户通过间歇性的检查自行决定。



注意！

除了更换易损件外，球阀几乎免维护。在运行期间，请确保球阀始终切换到打开或关闭的末端位置。中间位置可能会损坏密封壳，因此应加以避免。根据操作条件，必须检查填料函，必要时重新密封。



注意！

不得使用含有研磨剂或抛光剂的产品清洁阀门。

- 对于阀门维护，SPW FLOW 可提供完整的密封套件（参见备件清单）。
- 根据安装说明拆卸和安装密封件。
- 根据安装说明安装和调节旋转驱动装置。
- 旋转驱动装置的内部部件免维护。
- 在安装前，请为所有密封件涂上少量油脂。



注意！

必须确保使用与产品、应用和 CIP 清洁剂相容的密封材料。如有疑问，请联系您的 SPX FLOW 代表。



注意！

如果待加工的产品对硅敏感，则必须使用合适的油脂。

推荐：

APV 安装润滑脂（硅油基）

0.75 kg/ 罐装 - Ref.-Nr. H147382; 000-70-01-019/93

60 g/ 管装 - Ref.-Nr. H147381; 000-70-01-018/93

或者

APV 安装润滑脂（不含硅油）

0.6 kg/ 罐装 - Ref.-Nr. H147380; 000-70-01-017/93

60 g/ 管装 - Ref.-Nr. H147379; 000-70-01-016/93



不合适的润滑脂类型可能会影响功能和使用寿命。

12. 安装说明 BLV1 - H

手动操作不带反馈单元的球阀
项号参考下列示图。

12.1. 从管路系统上拆卸



注意！
球阀中可能仍残留有介质。



注意！

1. 关闭连接管路、释放管路压力，并尽量清空。
2. 用手杆 (11) 打开球阀。
3. 松开所有的紧固螺栓 (6)，取下未穿过壳体的上部螺栓。
4. 旋出壳体 (4)，将球阀 (5) 置于关闭位置，然后连同球座一起卸下。

12.2. 更换阀球和球座



注意！

拆下密封件后，阀球即可从壳体中释放。－ 阀球在关闭位置可能会掉出壳体外！ 请小心避免损坏阀球。

1. 卸下阀球 (5) 连同球座 (3)。检查阀球是否损坏，必要时进行更换。
2. 将阀球插入新的球座中。更换壳体密封环 (2)，然后组装球阀。
3. 拧紧所有紧固螺栓。

项号 1	连接法兰
项号 2*	外壳密封环
项号 3*	球座
项号 4	壳体
项号 5	阀球
项号 6	紧固螺栓
项号 8	衬套
项号 9	垫圈
项号 10	螺母
项号 11	手杆
项号 13	切换轴
项号 14*	切换轴密封件
项号 15*	填料函
项号 16	螺母
项号 17	垫圈
项号 *	垫圈组部件

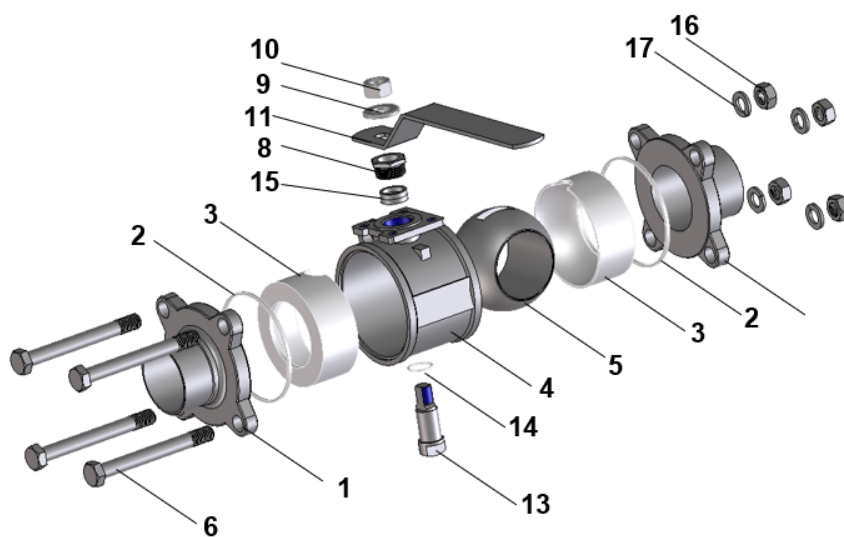

12. 安装说明 BLV1 - H

12.3. 更换切换轴密封件

有关项号请参考第 17 页示图。

1. 按照说明拆卸球阀。
2. 拆除手杆。为此，拆卸其上的螺母 (10) 与垫圈 (9)。
3. 从切换轴 (13) 上拆下衬套 (8)。
4. 从内部拆下切换轴 (13) 与开关轴密封件 (14)，并从壳体外部拆下填料函密封件 (15)。
5. 将新的切换轴密封件 (14) 与切换轴 (13) 通过壳体内部安装在一起。
6. 从壳体外部更换新的填料函密封件 (15)。
7. 拧紧填料函与衬套 (8)，有关拧紧力矩请参见 9.3。
8. 将阀门重新安装到先前指定的位置
9. 大约 48 小时后，拧紧衬套 (8)。

13. 安装说明 BLV1 - HL

带手动操作装置和反馈单元的球阀
有关项号请参考下列示图。

13.1. 从管路系统上拆卸



注意！
阀中可能仍残留有介质。



注意！

1. 关闭连接管路、释放管路压力，并尽量清空。
2. 拆除阀门位置反馈。
3. 有关进一步的拆卸信息，参见要点 12.1.2–12.1.4。

13.2. 拆卸主控台与手杆

1. 松开并卸下紧固螺钉 (1) 和垫圈 (2)。
2. 卸下手动操作装置，包括主控台 (3)、全套位置指示器 (4) 及任何转接板 (5)。
3. 有关进一步拆卸和更换阀球、球座和切换轴密封件的信息，参见要点 12.2. 及 12.3。

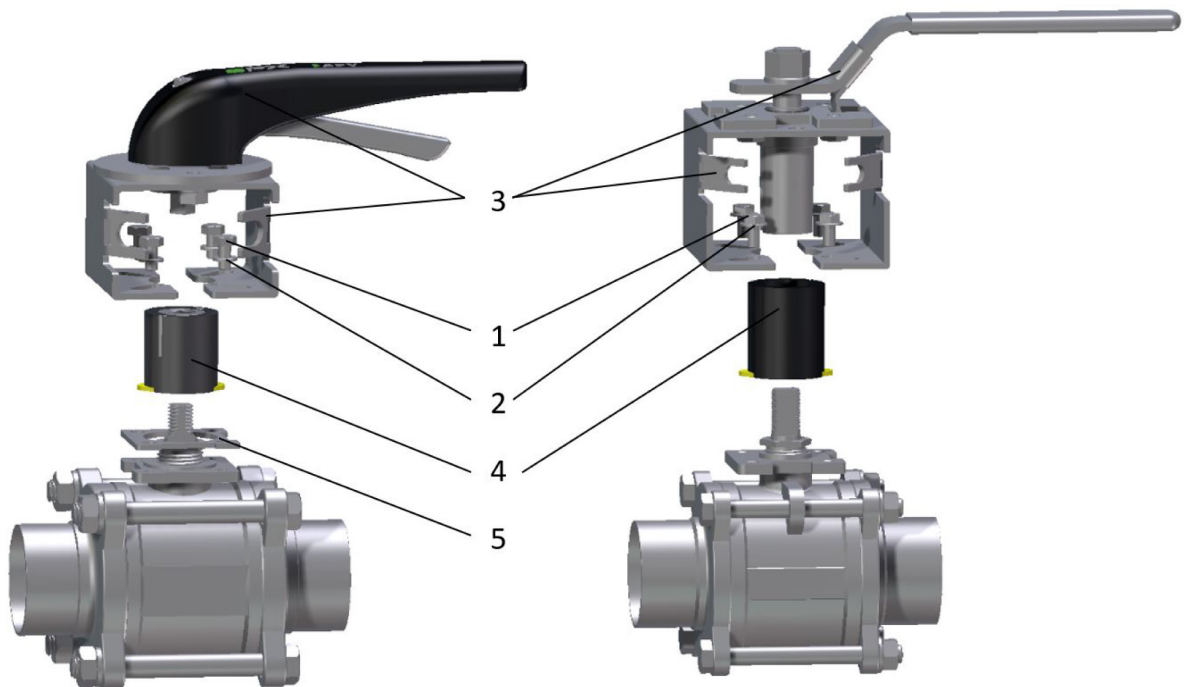

14. 安装说明 BLV1 - NC

带旋转驱动装置 / 控制单元的球阀
有关项号请参考下列示图。

14.1. 从管路系统上拆卸



注意！
阀中可能仍残留有介质。



- 注意！
1. 关闭连接管路、释放管路压力，并尽量清空。



- 注意！
2. 断开气动和电气连接。
 3. 拆除阀门位置反馈。
 4. 有关进一步的拆卸信息，参见要点 12.1.2–12.1.4。

14.2. 拆卸主控台与旋转驱动装置

1. 松开并卸下紧固螺钉 (1) 和垫圈 (2)。
2. 卸下旋转驱动装置，包括主控台 (3)、全套位置指示器 (4) 及任何转接板 (5)。
3. 有关进一步拆卸和更换阀球、球座和切换轴密封件的信息，参见要点 12.2. 及 12.3。

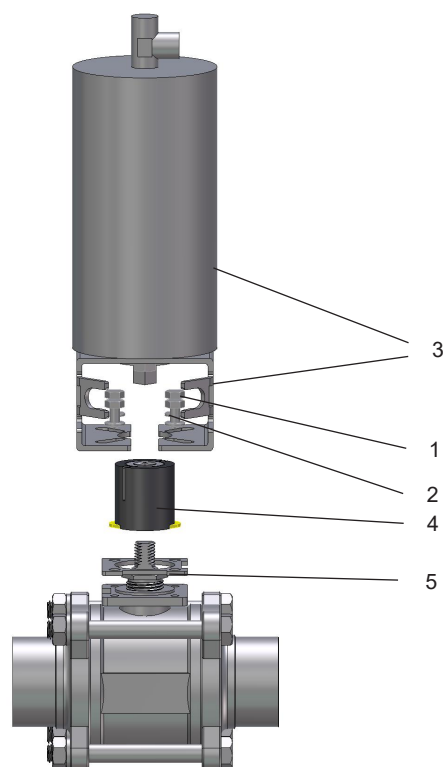

15. 备件清单

如果更换损坏的密封件，则通常应将所有密封件重新进行更换。

对于阀门维护，我们可提供完整的密封套件（参见备件清单）。

可在随附的备件图纸和相应的清单中查找各种阀门规格和尺寸的备件参考编号。

订购备件时，请提供以下数据：

- 需要的零件数量
- 产品编号 / 参考编号标识号
- 名称

保留更改权利

Information contained in this document is subject to change without notice and does not represent a commitment on the part of SPX FLOW, Inc.. No part of this document may be reproduced or transmitted in any form or by any means, electronic or mechanical, including photocopying and recording, for any purpose, without the express written permission of SPX FLOW, Inc..

Spare Parts list

Ball Valve-BLV1-HL DN15, 1/2" - DN50, 2"

Date:	28.02.19	10.07.19	20.08.19	19.03.25
Name:	R.Peters	R.Peters	R.Peters	C.Keil
Reviewed:				

SPX FLOW

Page 1 of 5

RN01-245-1

Date:	
Name:	
Reviewed:	

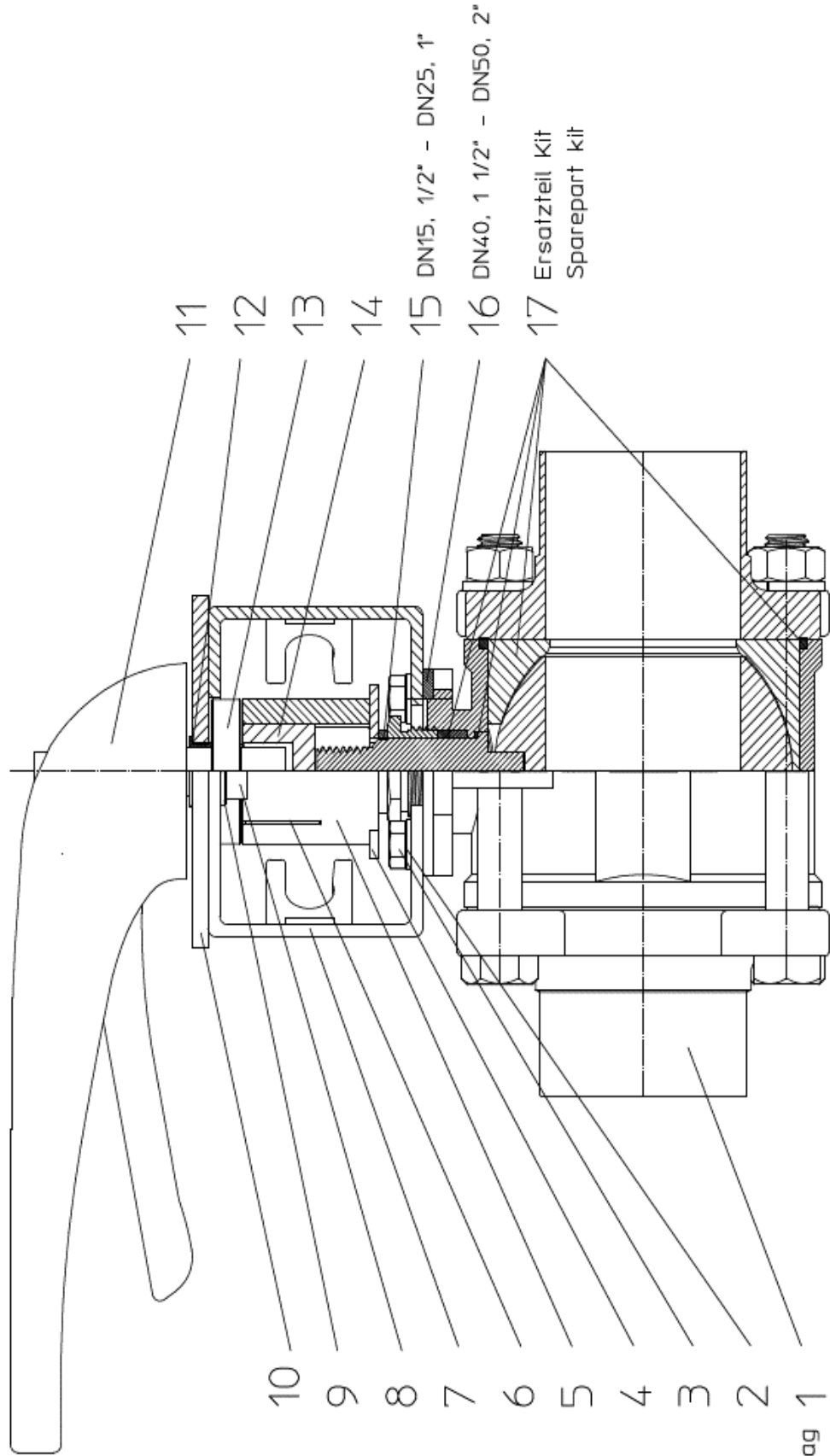

gemäß Auftrag 1
acc. order

Information contained in this document is subject to change without notice and does not represent a commitment on the part of SPX FLOW, Inc.. No part of this document may be reproduced or transmitted in any form or by any means, electronic or mechanical, including photocopying and recording, for any purpose, without the express written permission of SPX FLOW, Inc..

Spare Parts list

Ball Valve-BLV1-HL DN15, 1/2" - DN50, 2"

		Date: 28.02.19			10.07.19			20.08.19			19.03.25		
		Name: R.Peters			R.Peters			R.Peters			C.Keil		
		Reviewed:											
		Date:									Page 2 of 5		
		Name:									RN01-245-1		
		Reviewed:											
		DN20	3/4"	DN25	1"								SPX FLOW
Pos.	Qty.	Description	Material	DN15 Reference no. Part no.	1/2" Reference no. Part no.	3/4" Reference no. Part no.	DN20 Reference no. Part no.	DN25 Reference no. Part no.	1" Reference no. Part no.				
1	1	Ball valve BLV1-H-1+2S	1.4404 PTFE	30-15-434/57 H339740	30-15-416/57 H339724	30-15-417/57 H339725	30-15-435/57 H339741	30-15-436/57 H339742	30-15-418/57 H339726				
	1	Ball valve BLV1-H-1+2Clamp	1.4404 PTFE	30-15-453/57 H339748	30-15-425/57 H339732	30-15-426/57 H339733	30-15-444/57 H339749	30-15-445/57 H339750	30-15-427/57 H339734				
2	4	Washer	1.4301	67-01-014/13									
				A-5,3 H79587									
3	4	Hex. screw	1.4301	65-01-031/13									
				M5x10 H78734									
4	1	Visual Indicator	PE	08-29-095/93 H339637					08-29-096/93 H339638				
5	1	Indicator Holder	PE	08-52-229/92 H339633					08-52-230/92 H339634				
6	2	Indicator Pin	1.4305	67-15-031/13									
				H329220									
7	1	Bracket	1.4301	08-17-221/12 H339645					08-17-222/12 H339646				
8	2	Hex. screw	1.4301	65-01-074/15									
				M8x8 H334632									
9	2	Washer	1.4301	67-01-022/15									
				A-8,4 H79594									
10	1	Round plate	1.4301	08-58-026/17									
				H153637									
11	1	Manual actuating handle	PA6.6 30%GF	08-41-065/93									
				H15059									
12	1	Clips slide bearing	Iglidur	08-01-094/93									
				H169101									
13	1	Adapter manual BLV1	1.4301	08-48-093/17									
				H339648									
14	1	Adapter BLV1	1.4301	08-48-096/17 H339673					08-48-090/17 H339630				
15	1	Distance piece	PVC	08-48-032/93 H339643					08-48-033/93 H339644				

Information contained in this document is subject to change without notice and does not represent a commitment on the part of SPX FLOW, Inc.. No part of this document may be reproduced or transmitted in any form or by any means, electronic or mechanical, including photocopying and recording, for any purpose, without the express written permission of SPX FLOW, Inc..

Spare Parts list

Ball Valve-BLV1-HL DN15, 1/2" - DN50, 2"

Pos. Qty.		Description	Material	DN40		1 1/2"		DN50		2"	SPX FLOW	
				Reference no. Part no.	Reference no. Part no.	Reference no. Part no.	Reference no. Part no.	Reference no. Part no.	Date:		28.02.19	10.07.19
1	1	Ball valve BLV1-H-1+2S	1.4404 PTFE	30-15-437/57 H339743	30-15-419/57 H339727	30-15-451/57 H339744	30-15-420/57 H339728	Reviewed:		R.Peters	R.Peters	
1	1	Ball valve BLV1-H-1+2Clamp	1.4404 PTFE	30-15-454/57 H339751	30-15-428/57 H339735	30-15-447/57 H339752	30-15-429/57 H339736	Reviewed:				
2	4	Washer	1.4301	67-01-015/15 A6.4 H79589				Reviewed:				
3	4	Hex. screw	1.4301	65-01-055/13 M6x12 H78750				Reviewed:				
4	1	Visual Indicator	PE	08-29-097/93 H339639				Reviewed:				
5	1	Indicator Holder	PE	08-52-231/92 H339635				Reviewed:				
6	2	Indicator Pin	1.4305	67-15-031/13 H329220				Reviewed:				
7	1	Bracket	1.4301	08-17-222/12 H339646				Reviewed:				
8	2	Hex. screw	1.4301	65-01-074/15 M8x8 H334632				Reviewed:				
9	2	Washer	1.4301	67-01-022/15 A-8,4 H79594				Reviewed:				
10	1	Round plate	1.4301	08-58-026/17 H153637				Reviewed:				
11	1	Manual actuating handle	PA6.6 30%GF	08-41-065/93 H15059				Reviewed:				
12	1	Clips slide bearing	Iglidur	08-01-094/93 H169101				Reviewed:				
13	1	Adapter manual BLV1	1.4301	08-48-093/17 H339648				Reviewed:				
14	1	Adapter BLV1	1.4301	08-48-091/17 H339631				Reviewed:				
15	1	Distance piece	PVC	-----				Reviewed:				

Information contained in this document is subject to change without notice and does not represent a commitment on the part of SPX FLOW, Inc.. No part of this document may be reproduced or transmitted in any form or by any means, electronic or mechanical, including photocopying and recording, for any purpose, without the express written permission of SPX FLOW, Inc..

Spare Parts list

Ball Valve-BLV1-HL DN65, 2 1/2" - DN100, 4"

Date:	28.02.19	10.07.19	20.08.19	19.03.25
Name:	R.Peters	R.Peters	R.Peters	C.Keil
Reviewed:				

SPX FLOW

Page 1 of 2

RN01-245-3

Date:				
Name:				
Reviewed:				

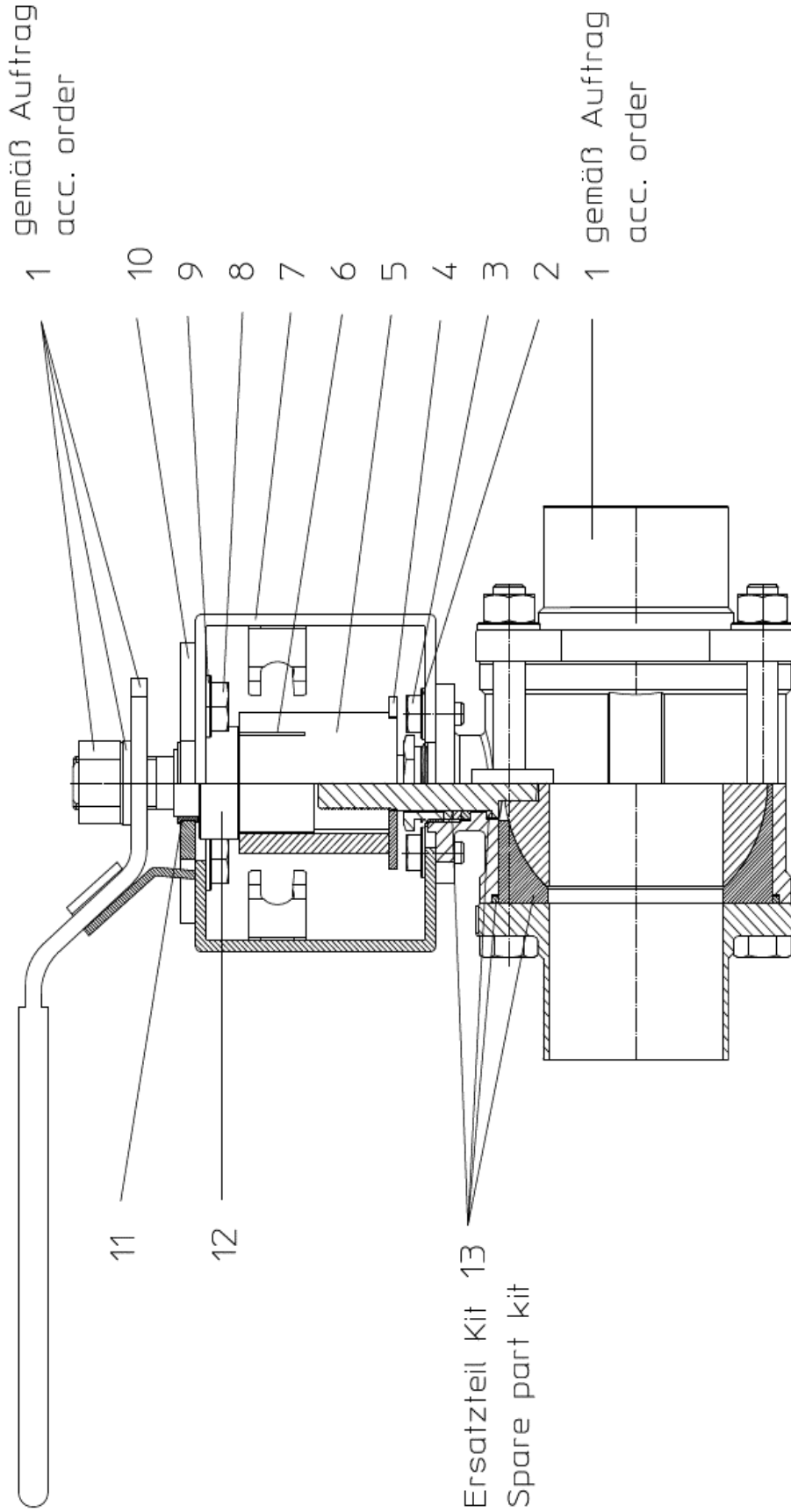

Information contained in this document is subject to change without notice and does not represent a commitment on the part of SPX FLOW, Inc.. No part of this document may be reproduced or transmitted in any form or by any means, electronic or mechanical, including photocopying and recording, for any purpose, without the express written permission of SPX FLOW, Inc..

Spare Parts list

Ball Valve-BLV1-NC DN15, 1/2" - DN100, 4"

Date:	28.02.19	10.07.19	20.08.19	19.03.25
Name:	R. Peters	R. Peters	R. Peters	C. Keil
Reviewed:				

Page 1 of 7

RN01-245-2

Date:	
Name:	
Reviewed:	

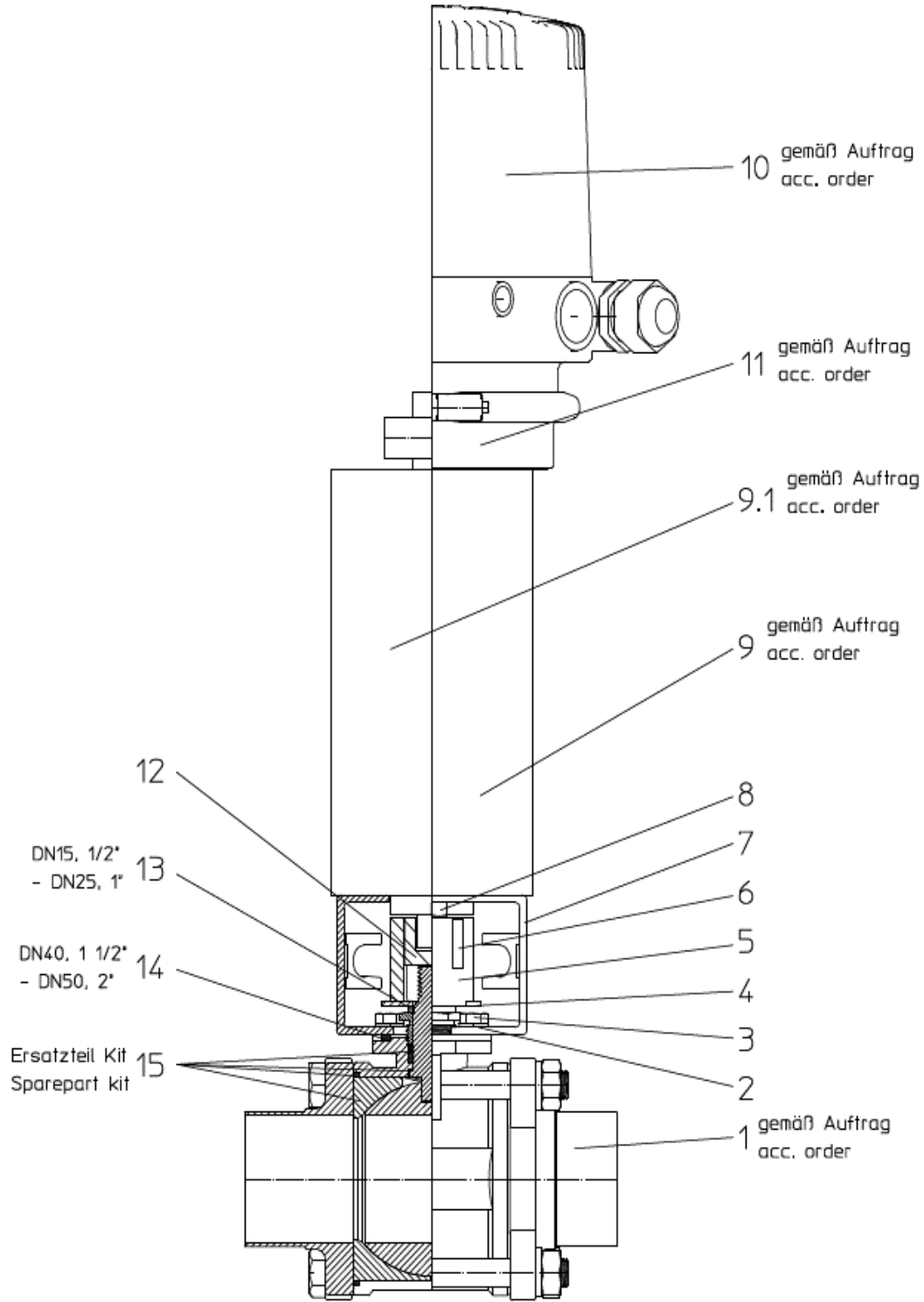

Information contained in this document is subject to change without notice and does not represent a commitment on the part of SPX FLOW, Inc.. No part of this document may be reproduced or transmitted in any form or by any means, electronic or mechanical, including photocopying and recording, for any purpose, without the express written permission of SPX FLOW, Inc..

Spare Parts list

Ball Valve-BLV1-NC DN15, 1/2" - DN100, 4"

		Date:	28.02.19	10.07.19	20.08.19	19.03.25	SPX FLOW		
		Name:	R.Peters	R.Peters	R.Peters	C.Keil			
		Reviewed:							
		Date:					Page	2 of 7	
		Name:					RN01-245-2		
		Reviewed:							
Pos.	Qty.	Description	Material	DN15	1/2"	DN20	3/4"	DN25	1"
		Reference no.	Reference no.	Reference no.	Reference no.	Reference no.	Reference no.	Reference no.	Reference no.
		Part no.	Part no.	Part no.	Part no.	Part no.	Part no.	Part no.	Part no.
1	1	Ball valve BLV1-H-1+2S	1.4404 PTFE	30-15-434/57 H339740	30-15-416/57 H339724	30-15-435/57 H339741	30-15-417/57 H339725	30-15-436/57 H339742	30-15-418/57 H339726
		Ball valve BLV1-H-1+2Clamp	1.4404 PTFE	30-15-453/57 H339748	30-15-425/57 H339732	30-15-444/57 H339749	30-15-426/57 H339733	30-15-445/57 H339750	30-15-427/57 H339734
2	4	Washer	1.4301	67-01-014/13 A-5.3 H79587					
3	4	Hex. screw	1.4301	65-01-031/13 M5x10 H78734					
4	1	Visual Indicator	PE	08-29-095/93 H339637	08-29-096/93 H339638				
5	1	Indicator Holder	PE	08-52-229/92 H339633	08-52-230/92 H339634				
6	2	Indicator Pin	1.4305	67-15-031/13 H329220					
7	1	Bracket	1.4301	08-17-221/12 H339645	08-17-222/12 H339646				
8	2	Hex. screw	1.4301	65-01-080/15 M8x12 H78770					
9	2	Actuator	1.4301	15-31-055/17 H105500					
9.1	1	Actuator prepared for CU	1.4301	15-37-070/17 H315055					
10	1	Control Unit CU4-T-Direct Connect	PA6.6 GF30 schwarz	08-45-101/93 H320461					
10.1	1	Control Unit CU4-T-ASI-standard	PA6.6 GF30 schwarz	08-45-251/93 H324674					
10.2	1	Control Unit CU4-T-ASI-extended	PA6.6 GF30 schwarz	08-45-111/93 H320468					
11	1	CU4-T-Adapter	PA6.6 GF30 schwarz	08-48-601/93 H320475					
12	1	Adapter BLV1	1.4301	08-48-096/17 H339673	08-48-090/17 H339630				

Information contained in this document is subject to change without notice and does not represent a commitment on the part of SPX FLOW, Inc.. No part of this document may be reproduced or transmitted in any form or by any means, electronic or mechanical, including photocopying and recording, for any purpose, without the express written permission of SPX FLOW, Inc..

Spare Parts list

Ball Valve-BLV1-NC DN15, 1/2" - DN100, 4"

		Date:	28.02.19	10.07.19	20.08.19	19.03.25	SPX FLOW					
		Name:	R.Peters	R.Peters	R.Peters	C.Keil						
		Reviewed:					Page 4 of 7					
		Date:					RN01-245-2					
		Name:										
		Reviewed:										
Pos.	Qty.	Description	Material	DN40	1 1/2"	DN50	2"	DN65	Reference no.	Part no.	Reference no.	Part no.
1	1	Ball valve BLV1-H-1+2S	1.4404 PTFE	30-15-437/57 H339743	30-15-419/57 H339727	30-15-451/57 H339744	30-15-420/57 H339728	30-15-439/57 H339745	30-15-421/57 H339729			
	1	Ball valve BLV1-H-1+2Clamp	1.4404 PTFE	30-15-454/57 H339751	30-15-428/57 H339735	30-15-447/57 H339752	30-15-429/57 H339736	30-15-448/57 H339753	30-15-430/57 H339737			
2	4	Washer	1.4301	67-01-015/15 A6.4 H79589								
3	4	Hex. screw	1.4301	65-01-055/13 M6x12 H78750								
4	1	Visual Indicator	PE	08-29-097/93 H339639								
5	1	Indicator Holder	PE	08-52-231/92 H339635								
6	2	Indicator Pin	1.4305	67-15-031/13 H329220								
7	1	Bracket	1.4301	08-17-222/12 H339646								
8	2	Hex. screw	1.4301	65-01-080/15 M8x12 H78770								
9	2	Actuator	1.4301	15-31-055/17 H105500								
9.1	1	Actuator prepared for CU	1.4301	15-37-070/17 H315055								
10	1	Control Unit CU4-T-Direct Connect	PA6.6 GF30 schwarz	08-45-101/93 H320461								
10.1	1	Control Unit CU4-T-ASI-standard	PA6.6 GF30 schwarz	08-45-251/93 H324674								
10.2	1	Control Unit CU4-T-ASI-extended	PA6.6 GF30 schwarz	08-45-111/93 H320468								
11	1	CU4-T-Adapter	PA6.6 GF30 schwarz	08-48-601/93 H320475								
12	1	Adapter BLV1	1.4301	08-48-091/17 H339631								
				08-48-611/93 H321987								
				08-48-092/17 H339632								

Information contained in this document is subject to change without notice and does not represent a commitment on the part of SPX FLOW, Inc.. No part of this document may be reproduced or transmitted in any form or by any means, electronic or mechanical, including photocopying and recording, for any purpose, without the express written permission of SPX FLOW, Inc..

Spare Parts list

Ball Valve-BLV1-NC DN15, 1/2" - DN100, 4"

		Date:	28.02.19	10.07.19	20.08.19	19.03.25		
		Name:	R.Peters	R.Peters	R.Peters	C.Keil		
		Reviewed:						
		Date:					Page	6 of 7
		Name:					RN01-245-2	
		Reviewed:						
Pos.	Qty.	Description	Material	DN80	3"	DN100	4"	
				Reference no.	Reference no.	Reference no.	Reference no.	
				Part no.	Part no.	Part no.	Part no.	
1	1	Ball valve BLV1-H-1+2S	1.4404 PTFE	30-15-440/57 H339746	30-15-422/57 H339730	30-15-452/57 H339747	30-15-423/57 H339731	
	1	Ball valve BLV1-H-1+2Clamp	1.4404 PTFE	30-15-449/57 H339754	30-15-431/57 H339738	30-15-450/57 H339755	30-15-432/57 H339739	
2	4	Washer	1.4301	67-01-022/15 A8,4 H79594		67-01-013/15 A-10,5 H79586		
3	4	Hex. screw	1.4301	65-01-081/15 M8x16 H78772		65-01-132/15 M10x20 H78809		
4	1	Visual Indicator	PE	08-29-098/93 H339640		08-29-099/93 H339778		
5	1	Indicator Holder	PE	08-52-232/92 H339636		08-52-239/12 H339777		
6	2	Indicator Pin	1.4305	67-15-031/13 H329220				
7	1	Bracket	1.4301	08-17-223/12 H339647				
8	2	Hex. screw	1.4301	67-01-129/15 M10x14 H78805				
9	2	Actuator	1.4301	15-31-057/17 H105502		15-31-923/17 H32589		
9.1	1	Actuator prepared for CU	1.4301	15-37-106/17 H128942		15-37-103/17 H134034		
10	1	Control Unit CU4-T-Direct Connect	PA6.6 GF30 schwarz	08-45-101/93 H320461				
10.1	1	Control Unit CU4-T-ASI-standard	PA6.6 GF30 schwarz	08-45-251/93 H324674				
10.2	1	Control Unit CU4-T-ASI-extended	PA6.6 GF30 schwarz	08-45-111/93 H320468				
11	1	CU4-T-Adapter	PA6.6 GF30 schwarz	08-48-611/93 H321987				
12	1	Adapter BLV1	1.4301	08-48-092/17 H339632		08-48-098/17 H339776		

Information contained in this document is subject to change without notice and does not represent a commitment on the part of SPX FLOW, Inc.. No part of this document may be reproduced or transmitted in any form or by any means, electronic or mechanical, including photocopying and recording, for any purpose, without the express written permission of SPX FLOW, Inc..

Spare parts list

Actuator K080, K125, K180 spring/air

Date:	22.11.12	12.03.14	SPX FLOW	
Name:	Trytko	Trytko		
Reviewed:	Goebel			
Date:			Page	1 of 2
Name:				
Reviewed:				RN 01.073

DRAT K080

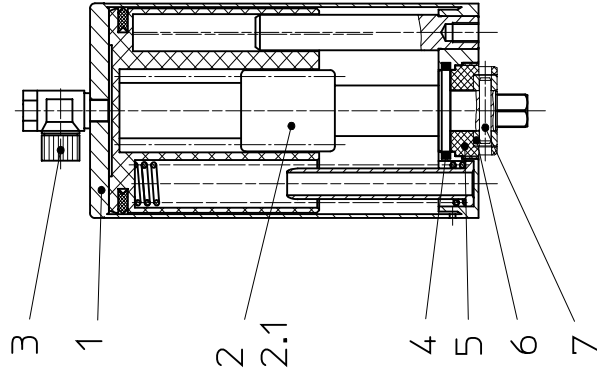

DRAT K125

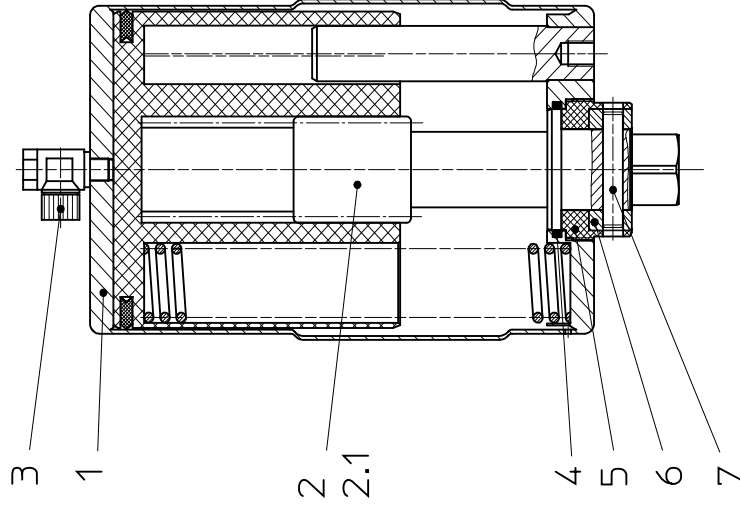

DRAT K180

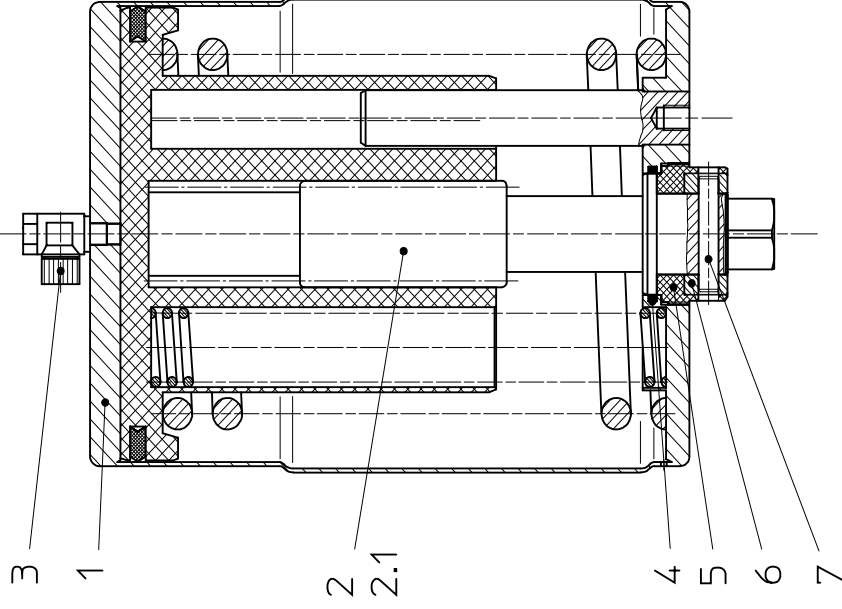

Information contained in this document is subject to change without notice and does not represent a commitment on the part of SPX FLOW, Inc.. No part of this document may be reproduced or transmitted in any form or by any means, electronic or mechanical, including photocopying and recording, for any purpose, without the express written permission of SPX FLOW, Inc..

Spare parts list

Actuator K080, K125, K180 spring/air

Pos. Item	Quantity	Description	Material	K080		K125		K180		Reference no. Part no.	Reference no. Part no.	Reference no. Part no.
				Reference no. Part no.	Reference no. Part no.	Reference no. Part no.	Reference no. Part no.					
1	1	Actuator complete	1.4301 satin finish	15-31-055/17 H105500	15-31-057/17 H105502	15-31-923/17 H32589						
1	1	Actuator complete	1.4301 polished	15-31-055/13 H135919	15-31-057/13 H131940	15-31-923/13 H32588						
1	1	Actuator welded	1.4301	15-31-054/17 H105499	15-31-056/17 H105501	15-31-922/17 H32587						
2	1	Shaft complete with bearing	1.4301	15-24-021/13 H31494	15-24-031/13 H31502	15-24-033/13 H31504						
2.1	1	Shaft	1.4301	15-24-020/13 H31493	15-24-030/13 H31501	15-24-032/13 H31503						
3	1	Elbow union G1/8" slewable	polyamide/ glass fibre	08-63-221/93 H16371								
4	1	O-ring	NBR	58-06-130/83 32,2x3 H76965								
4	1	O-ring	FPM		58-06-222/73 49,5x3 H77000							
5	1	Bearing for actuator	POM	15-28-002/34 H31673								
5	1	Bearing for actuator	PA12		15-28-009/63 H31684							
6	1	Adjust ring	1.4301	67-08-007/13 H79757	67-08-008/13 H79758							
7	1	Cyl. pin	DIN EN ISO 8740-V2A	67-15-035/13 5x26 H79916	67-15-036/13 8x45 H79917							

Information contained in this document is subject to change without notice and does not represent a commitment on the part of SPX FLOW, Inc.. No part of this document may be reproduced or transmitted in any form or by any means, electronic or mechanical, including photocopying and recording, for any purpose, without the express written permission of SPX FLOW, Inc..

Spare parts list

Actuator K080, K125, K180 spring/air for control unit

Date:	28.03.13	08.05.14	07.02.25	SPX FLOW	
Name:	Trytko	Trytko	C.Keil		
Reviewed:					
Date:				Page	1 of 2
Name:				RN 01.076	
Reviewed:					

DRAT K080-RM

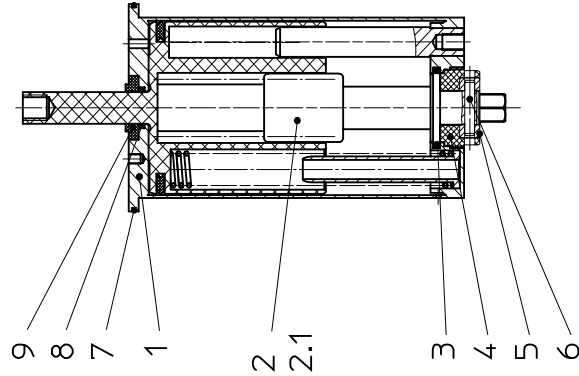

DRAT K125-RM

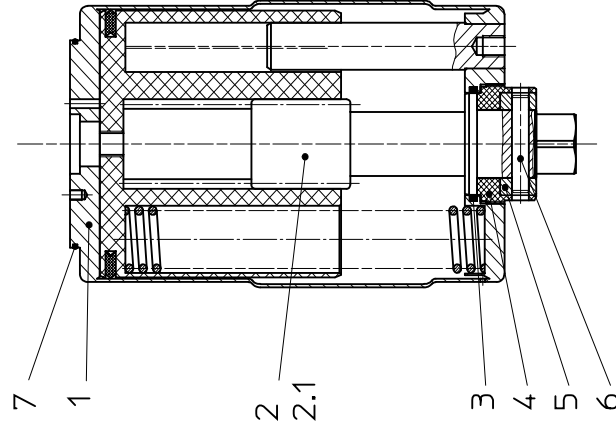

DRAT K180-RM

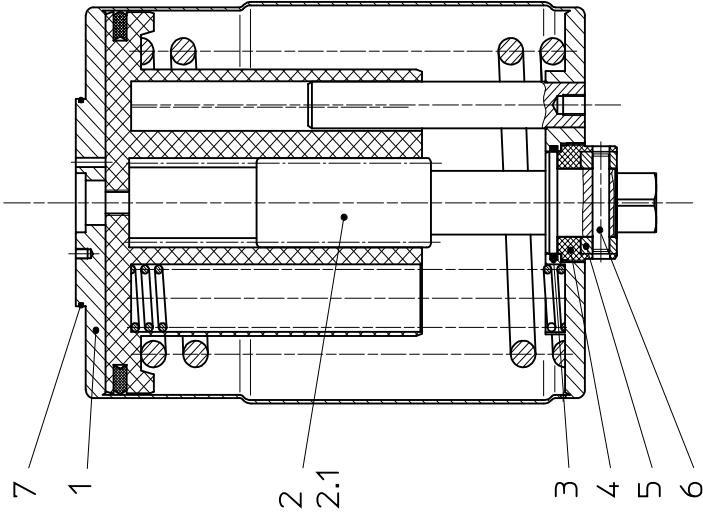

Information contained in this document is subject to change without notice and does not represent a commitment on the part of SPX FLOW, Inc.. No part of this document may be reproduced or transmitted in any form or by any means, electronic or mechanical, including photocopying and recording, for any purpose, without the express written permission of SPX FLOW, Inc..

Spare parts list

Actuator K080, K125, K180 spring/air for control unit

Pos. Item	Quantity	Description	Material	K080		K125		K180		SPX FLOW		
				Reference no. Part no.	Reference no. Part no.	Reference no. Part no.	Reference no. Part no.	Reference no. Part no.	Reference no. Part no.	Reference no. Part no.		
1	1	Actuator complete	1.4301 satin finish	15-37-070/17 H315055	15-37-106/17 H128942	15-37-103/17 H134034						
1	1	Actuator complete	1.4301 polished	15-37-070/13 H316969	15-37-106/13 H327700	15-37-103/13 H328071						
1	1	Actuator welded	1.4301	15-37-071/17 H123936	15-37-105/17 H128940	15-37-104/17 H134503						
2	1	Shaft complete with bearing	1.4301	15-24-021/13 H31494	15-24-031/13 H31502	15-24-033/13 H31504						
2.1	1	Shaft	1.4301	15-24-020/13 H31493	15-24-030/13 H31501	15-24-032/13 H31503						
3	1	O-ring	NBR	58-06-130/83 H76965								
	1	O-ring	FPM		58-06-222/73 H77000							
	1	Bearing for actuator	POM	15-28-002/34 H31673								
4	1	Bearing for actuator	PA12		15-28-009/63 H31684							
5	1	Adjust ring	1.4301	67-08-007/13 H79757	67-08-008/13 H79758							
6	1	Cyl. pin	1.4305	67-15-035/13 5x26 H79916	67-15-036/13 8x45 H79917							
7	1	O-ring	NBR		58-06-426/83 H143352							
8	1	O-ring	NBR	58-06-052/83 H107914								
9	1	Thrust ring turning actuator	Hostaform	08-48-117/53 H105080								

APV BLV1

球阀

SPXFLOW[®]

SPX FLOW

Design Center

Gottlieb-Daimler-Straße 13
D-59439 Holzwickede, Germany
P: (+49) (0) 2301-9186-0
F: (+49) (0) 2301-9186-300

SPX FLOW

Production

Stanisława Jana Rolbieskiego 2
PL- Bydgoszcz 85-862, Poland
P: (+48) 52 566 76 00
F: (+48) 52 525 99 09

SPX FLOW 保留技术变更和重大更改的权利，恕不另行通知。

本文件中提及的设计特性、材料和尺寸仅供参考。未经进一步书面确认，概不保证信息的准确性。有关产品的可用性，请联系您当地经销商。
如需了解更多信息，请访问我们的网站: www.spxflow.com

发布日期: 08/2021 - 原版使用说明书翻译版

COPYRIGHT ©2021 SPX FLOW, Inc.