

APV BLV1

BALL VALVE

FORM NO.: H341809 REVISION: GB-3

READ AND UNDERSTAND THIS MANUAL PRIOR TO OPERATING OR SERVICING THIS PRODUCT.



We,

DESIGN CENTER:

SPX Flow Technology Germany GmbH
Gottlieb-Daimler-Str. 13, D-59439 Holzwickede

MANUFACTURER:

SPX Flow Technology Poland sp. z o.o.
Rolbieskiego 2, 85-862 Bydgoszcz, Poland

**AUTHORIZED REPRESENTATIVE:
(for UKCA)**

SPX Flow, Inc.
Alexander House, 4 Station Road
Cheadle Hulme, Cheadle SK3 5AE UK

declare under our sole responsibility that the

APV double seal and double seat valves of the series
AM1, SD4, SDT4, SDU4, SDMS4, SDMSU4, SDTMS4, SWcip4, DSV, DA4, DA4 DPF, D4 SL,
DU4 SL, DT4 SL, DP4 SL, D4, DA3, DA3SLD, DE3, DEU3, DET3, DKR2, DKRT2, DKRH2

APV butterfly valves of the series SV1, SVS1F, SV2, SVS2F, SVL, SVSL, SVE, SVSE

APV ball valves of the series BLV1

APV single seat, diaphragm and spring loaded valves of the series
S2, SW4, SWhp4, SW4DPF, SWmini4, SWT4, SWS4, MF4, MS4, MSP4, AP/T1, CPV, RG4,
RG4DPF, RGMS4, RGE4, RGE4DPF, RGEMS4, PR2, PRD2, SI2, UF/R3, UF/R4, UFHP4,
UFMS4, VRA/H

and the valve manifolds installed thereof

**meet the requirements of the Machinery Directive 2006/42/EC
& EN ISO 12100-2010, DIN EN ISO 14159-2008-07, DIN EN 1672-2-2009-07.**

Holzwickede, Germany Dec. 2024

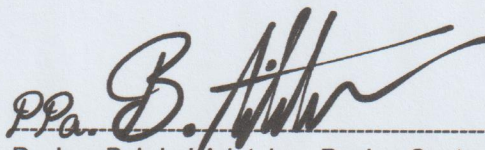

Dr.-Ing. Behdad Ariatabar, Design Center Lead - Valves

**meet the requirements of the Supply of Machinery (Safety) Regulations 2008 No. 1597
& BS harmonized standards.**

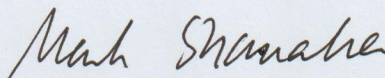

Manchester, England Dec. 2024

Mark Shanahan, VP Finance N&H Solutions

Content	Page
1. General Terms	6
2. Safety	6
2.1. Symbols	
2.2. Safety Instructions	
3. Intended Use	7
4. Mode of Operation	8
4.1. General information	
5. Auxiliary Equipment	9
5.1. Valve position indication - manual / actuated valve	
5.2. Control unit	
5.3. Turning actuator for control unit	
6. Cleaning	10
6.1. Cleaning recommendation	
7. Installation and Commissioning	11
7.1. Welding Instructions	
8. Dimensions / Weights	12
8.1. BLV1 - H - DN 15 - 100; ½" - 4" Ball valve, manually operated, without feedback	
8.2. BLV1 - HL - DN 15 - 100; ½" - 4" Ball valve, manually operated, with feedback	
8.3. BLV1 - NC - DN 15 - 100; ½" - 4" Ball valve, actuated, with turning actuator / control unit	
9. Technical Data	14
9.1. General data	
9.2. Compressed air quality	
9.3. Max. tightening torque	
9.4. Pneumatic air consumption	
10. Materials	15
11. Maintenance	16
12. Service Instructions BLV1 - H	17
12.1. Removal from the line system	
12.2. Replacement of ball and ball seats	
12.3. Replacement of stem seal	
13. Service Instructions BLV1 - HL	19
13.1. Removal from the line system	
13.2. Removal of bracket with handle	
14. Service Instructions BLV1 - NC	20
14.1. Removal from the line system	
14.2. Removal of bracket with turning actuator	
15. Spare Parts Lists	21
BLV1 - HL DN 15 - DN 50 and 1/2" – 2"	RN 01.245 - 1
BLV1 - HL DN 65 - DN 100 and 2 1/2" - 4"	RN 01.245 - 3
BLV1 - NC DN 15 - DN 100 and 1/2" – 4"	RN 01.245 - 2
Turning actuator K-080, K-125, K-180	RN 01.073
Turning actuator K-080, K-125, K-180 for control unit	RN 01.076

1. General Terms

This instruction manual should be read carefully by the competent operating and maintenance personnel.

We point out that we will not accept any liability for damage or malfunctions resulting from the non-compliance with this instruction manual.

Descriptions and data given herein are subject to technical changes.

2. Safety

2.1. Symbols



Caution!

The technical safety symbol draws your attention to important directions for operating safety. You will find it wherever the activities described are bearing health hazards and risks for persons and / or material assets.



Important Note!

Critical technical information

2.2. Safety Instructions



Opening of the actuators and upper shafts is strictly forbidden. Danger to health and life!

Actuators which are no longer used and/or are defective must be disposed in professional manner.

Defective actuators must be returned to your SPX FLOW company for their professional disposal and free of charge for you.

Please address to your local SPX FLOW company.



- Never touch the ball valve or pipelines during hot liquid processes!



- **Do not touch the open valve ball or yoke!**
Risk of injury by sudden valve operation.



- In dismantled valve state, there is the risk of bruising at movable valve parts.

2. Safety



- Before any maintenance work, **depressurize** the line and cleaning system and discharge the lines if possible.



- Disconnect electric and pneumatic connections.



- During disassembly you may find liquid residues in the valve ball.



- Remove the turning actuator before the replacement of seals.



- Observe Service Instructions to ensure safe maintenance of the valve.



- Regular maintenance of the valve including replacement of all seals must be scheduled in order to prevent leakages and liquid emersion.



- The valves must be assembled, disassembled and reassembled only by persons who have been trained in the valves or by SPX FLOW service team members. If necessary, contact your local SPX FLOW representative.

3. Intended Use

The intended use as field of application of the ball valve is the shut-off of pipeline sections.



Caution! Arbitrary, structural changes at the valves may affect safety as well as the intended functionality of the valves and are not permitted.



Caution! The standard BLV1 ball valve must not be used in explosive atmospheres.



Caution! The standard BLV1 ball valve must not be used in hygienic applications.

SPX FLOW APV Valves are intended for use in the food and beverage industries, as well as in pharmaceutical and chemical applications.

SPX FLOW APV Valves (without safety function) are allocated to Category 1 and are evaluated as per Conformity Assessment Module A of the Pressure Equipment Directive 2014/68/EU. According to Article 13, the following allocation applies for the fluids processed in the valves.

Product media – Fluid group 2 – valves in all dimensions.

CIP-cleaning liquids – Fluid group 1 – valves in the dimensions \leq DN100/4" can be used at temperatures up to 140 °C, valves in the dimensions $>$ DN100/4" at temperatures up to 100 °C.

3. Intended Use

Authorizations and External Approvals

To view the certifications for this and other innovative SPX FLOW products, visit
<https://www.spxflow.com/en/apv/about-us/certifications/>

It is within the responsibility of the plant operator to evaluate and verify the suitability of SPX FLOW products for the intended purpose and service conditions, as well as to determine and follow the applicable laws for the intended applications and areas of application.

4. Mode of Operation

4.1. General information

Smooth valve passage with full opening cross section in the size of the pipeline nominal diameter.

There are three different valve designs:

- **BLV1-H** ball valve - standard with handle without feedback
- **BLV1-HL** ball valve - with handle and bracket for feedback
- **BLV1-NC** ball valve - controlled by pneumatic actuator

- Due to the use of high quality stainless steel and adequate seal materials, the BLV1 ball valve is suited for applications in the food and beverage industries as well as in pharmaceutical and chemical applications.

Attention!

As the ball valve possesses dead spaces which cannot be cleaned, **it should not be used in product-wetted areas of the food processing industry!**

- As shut-off element, the ball is fitted in PTFE seats at both sides. Through the floating position of the ball, in closed position a movement into the flow direction becomes possible providing for optimum sealing in the passage (**B and C**).

- The stem of the ball cock is generally inserted from the inside. Therefore, a collar being bigger than the bore of the body prevents the stem from being pressed to the outside. The stem sealing is taken over by the stem packing which is braced via a threaded bush.

- The sealing between body and counterflange to the outside is effected by the PTFE body seal in standard design.

Note!

The ball cock is not equipped with a separate CIP connection to clean the existing dead spaces.

- Actuation by pneumatic turning actuator with air connection at (**A**), reset by spring force into the limit position “**closed**”.

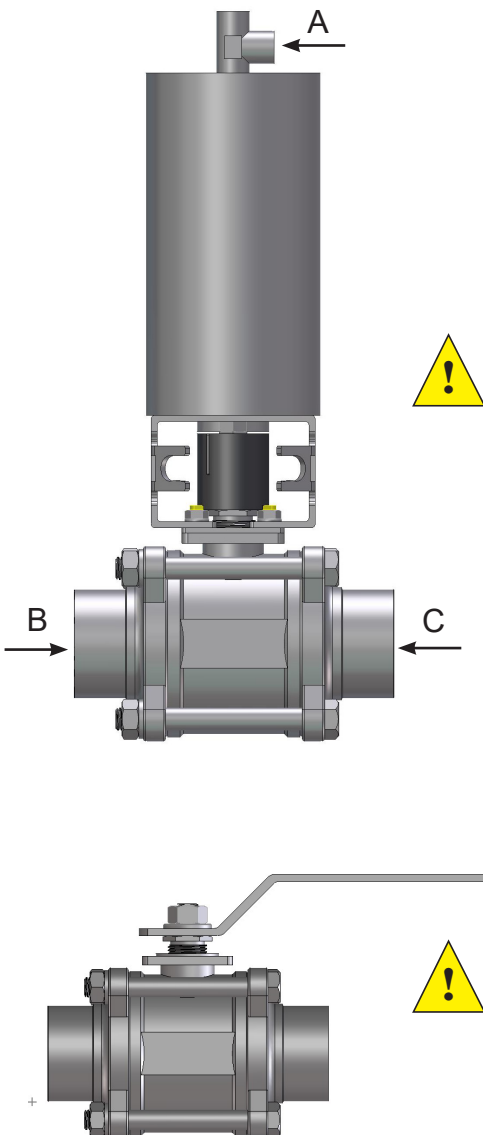

5. Auxiliary Equipment

ball cock, manually operated, with yoke for feedback of ball position

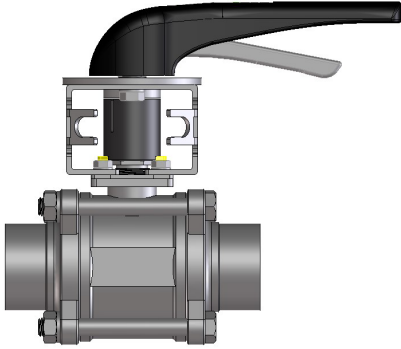

5.1. Valve position indication - manual / actuated valve

Proximity switches to signal the final position of the valve ball can be installed in the yoke area if required.

We recommend using one of these standard types:
 three-wire proximity switch (H340207; 000-08-60-114/93)
 operating distance: 5 mm / diameter: M12 / length: 40 mm

If the customer decides to use valve position indicators other than those listed above, SPX FLOW cannot assume any liability for the functionality of the valve.

1 proximity switch for the feedback of the ball position closed or open.

2 proximity switches for the feedback of the two ball positions open or closed.

CU4 control unit



5.2. Control unit

Units with feedback switches and solenoid valves for the pneumatic control of the valve to be assembled on the turning actuator are also available in fieldbus technology. The assembly of the control unit on the prepared variant of the turning actuator is possible.

For the startup as well as assembly and disassembly of the different designs, the corresponding instruction manuals must be observed.

The following different designs are available:

CU4 - Direct Connect reference numbers	CU41 - T - Direct Connect H320461; 000-08-45-101/93
CU4 - AS-interface reference numbers	CU41 - T - AS-i extended H320468; 000-08-45-111/93

5. Auxiliary Equipment

5.3. Turning actuator for control unit

For the assembly of a control unit on the ball valve, a special turning actuator is required.

The standard turning actuator must be replaced.

Turning actuator for control unit	
actuator K080 F/L RME for BLV1 DN 15 - 50; 1/2"- 2"	H123937 000-15-37-070/17
actuator K125 F/L RME for BLV1 DN 65 - 80; 2 1/2"- 3"	H128942 000-15-37-106/17
actuator K180 F/L RME for BLV1 DN 100; 4"	H134034 000-15-37-103/17

- For the assembly of the control unit on the special turning actuator, a CU adapter is required.

Adapter for control unit CU4-T	
CU4-T-adapter DN 15 - 50; 1/2" – 2"	H320475 000-08-48-601/93
CU4-Tmax-adapter DN 65 - 100; 2 1/2" - 4"	H321987 000-08-48-611/93

6. Cleaning

6.1. Cleaning recommendation

The valve passage is cleaned by the cleaning liquid during cleaning of the connected pipelines.

Depending on the degree and contents of soiling, the cleaning liquids, times and processes for the individual application must be scheduled.



Caution!

The cleaning liquid applied must be compatible with the respective seal material.

7. Installation and Commissioning

The installation position of the ball valve is arbitrary and can be selected according to the local situation and the task to be fulfilled.



Note! Observe welding instructions 7.1.



Caution!

Before first startup:

- Check the function of the control unit or valve position indication if installed.
- Check for possible leakages during commissioning. Replace defective seals.

7.1 Welding Instructions

- Before welding of the valve, remove all sensitive parts! Dismantle the valve ball body with seals from the mating flanges.
- Welding should only be carried out by certified welders (DIN EN ISO 9606-1) (seam quality DIN EN ISO 5817).
- The welding of the valve bodies must be undertaken in such a way that the valve body is not deformed.
- TIG orbital welding is recommended.
- The preparation of the weld seam up to 3 mm thickness must be carried out as a square butt joint without air. Consider shrinkage!



Caution!

After welding the mating flanges, and after performing any work on the piping, do not operate the valves until the corresponding areas of the installation and piping have been cleaned and welding residue has been removed. If the piping is not cleaned before operation, welding residue and dirt particles can settle in the valves and cause damage to the valves and seals.

- If these welding instructions are not followed, any resulting damage will not be covered by the warranty.

8. Dimensions / Weights

8.1. BLV1 - H - DN 15 - 100; 1/2" - 4" Ball valve, manually operated, without feedback

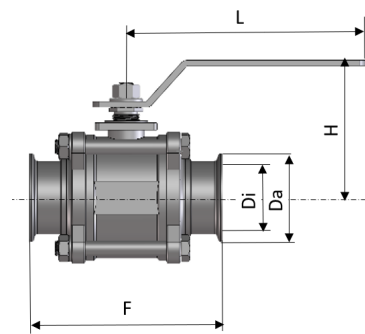
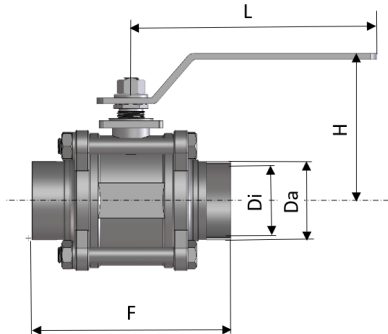

dimensions in mm						weight in kg
DN	Di	Da	F	L	H	
15	16	19	88	132	64	0,75
20	20	23	101	132	69	0,85
25	26	29	114	165	69	1,00
40	38	41	139	194	88	2,20
50	50	53	155	194	97	3,65
65	66	70	197	251	131	7,65
80	81	85	229	251	144	10,55
100	100	104	243	332	172	19,15

dimensions in mm						weight in kg
DN	Di	Da	F	L	H	
15	16	34	88	132	64	0,75
20	20	34	101	132	69	0,85
25	26	50,5	114	165	69	1,00
40	38	50,5	139	194	88	2,20
50	50	64	155	194	97	3,65
65	66	91	197	251	131	7,65
80	81	106	229	251	144	10,55
100	100	119	243	332	172	19,15

dimensions in mm						weight in kg
Inch	Di	Da	F	L	H	
1/2"	9,4	12,7	88	132	64	0,75
3/4"	15,8	19,1	101	132	69	0,85
1"	22,2	25,4	114	165	69	1,00
1 1/2"	34,9	38,1	139	194	88	2,20
2"	47,6	50,8	155	194	97	3,65
2 1/2"	60,3	63,5	197	251	131	7,65
3"	72,9	76,1	229	251	144	10,55
4"	97,6	101,6	243	332	172	19,15

dimensions in mm						weight in kg
Inch	Di	Da	F	L	H	
1/2"	9,4	25	88	132	64	0,75
3/4"	15,8	25	101	132	69	0,85
1"	22,2	50,5	114	165	69	1,00
1 1/2"	34,9	50,5	139	194	88	2,20
2"	47,6	64	155	194	97	3,65
2 1/2"	60,3	77,5	197	251	131	7,65
3"	72,9	91	229	251	144	10,55
4"	97,6	119	243	332	172	19,15

8.2. BLV1 - HL - DN 15 - 100; 1/2" - 4" Ball valve, manually operated, with feedback

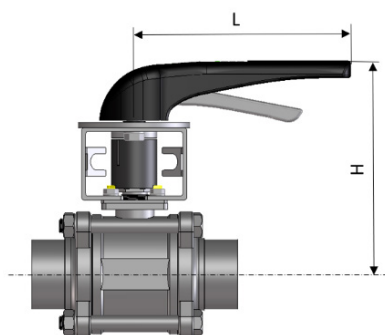

DN15 - DN50; 0,5" - 2"

dimensions in mm				weight in kg
DN	Inch	H	L	
15	1/2"	132	165	1,50
20	3/4"	137	165	1,70
25	1"	140	165	1,90
40	1 1/2"	154	165	3,00
50	2"	162	165	4,40
65	2 1/2"	234	251	9,30
80	3"	247	251	12,2
100	4"	275	332	21,0

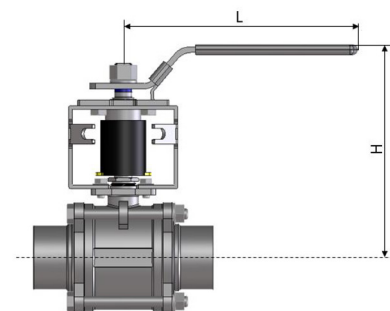

DN65 - DN100; 2,5" - 4"

8. Dimensions / Weights

8.3. BLV1 - NC - DN 15 - 100; 1/2" - 4" Ball valve, actuated, with turning actuator / control unit

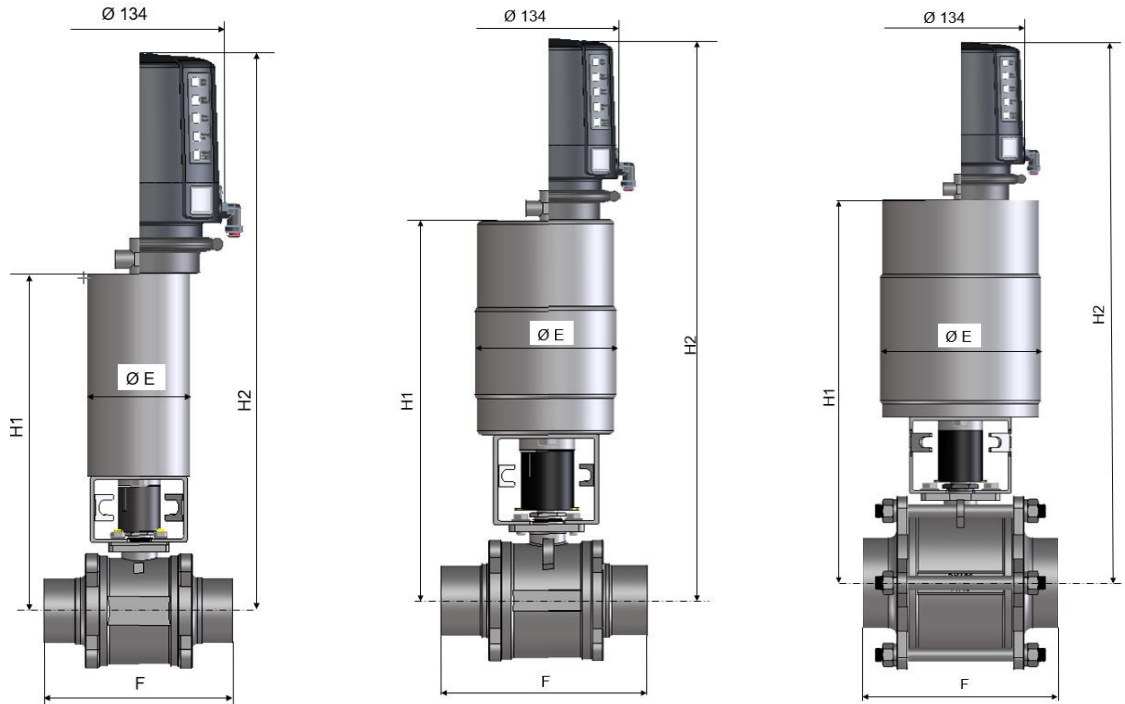

dimensions in mm						weight kg	weight kg
DN	Inch	F	E	H1	H2	without CU	with CU
15	1/2"	88	85	250	429	3,7	4,9
20	3/4"	101	85	255	434	3,9	5,1
25	1"	114	85	258	437	4,1	5,3
40	1 1/2"	139	85	272	451	5,2	6,4
50	2"	155	85	280	459	6,6	7,8
65	2 1/2"	197	135	382	561	16,7	17,9
80	3"	229	135	392	571	19,6	20,8
100	4"	243	189	453	632	37,0	38,2

9. Technical Data

9.1. General data

- max. line pressure:

Inch sizes	DN sizes		max. line pressure at max. 140 °C (bar)
1/2"	15		63
3/4"	20		63
1"	25		63
1,5"	40		40
2"	50		40
2,5"	65		25
3"	80		25
4"	100		20



Caution!

Only use TC clamps that correspond to the pressure level used in the system (possibly high-pressure TC connection)!

- max. operating temperature: 0 - 140 °C
- short-term steam load: 160 °C
- turning actuator
 - min. pneumatic air pressure: 6 bar
 - max. pneumatic air pressure: 10 bar
 - turning angle: 90°
- air connection (for hose): 6 x 1
 - angle union - G1/8"
 - sleable: tightening torque 2 Nm

9.2. Compressed air quality

Quality class	acc. to DIN ISO 8573-1
Content of solid particles	quality class 3, max. size of solid particles per m ³ 10000 of 0,5 µm ≤ d ≤ 1,0 µm 500 of 1.0 µm ≤ d ≤ 5,0 µm
Content of water	quality class 3, max. dew point temperature -20°C For installations at lower temperatures or at higher altitudes, consider additional measures to reduce the pressure dew point accordingly.
Content of oil	quality class 1, max. 0,01 mg/m ³

The oil applied must be compatible with Polyurethane elastomer materials.

9. Technical Data

9.3. Max. tightening torque

Tightening torques, allocation of actuator size

ball valve	nominal dimension							
DN	15	20	25	40	50	65	80	100
Inch	1/2"	3/4"	1"	1 1/2"	2"	2 1/2"	3"	4"
turning actuator	K080				K125			K180
tightening torque (Nm)	5,0	6,5	9,5	18,0	23,5	59,5	64	96
ball valve								
DN	15	20	25	40	50	65	80	100
Inch	1/2"	3/4"	1"	1 1/2"	2"	2 1/2"	3"	4"
stem packing tightening torque (Nm)	9,0	9,0	11,0	28,0	28,0	34,0	57,0	80,0
body bolt tightening torque (Nm)	11,3	12,5	13,5	30,0	30,0	40,0	50,0	60,0

9.4. Pneumatic air consumption

turning actuator	pneumatic air consumption per stroke
K080	1,8 NI
K125	5,5 NI
K180	11 NI

10. Materials

- ball	1.4404 (DIN EN 10088)
- body	1.4408/1.4404 (DIN EN 10088)
- yoke, actuator	1.4301 (DIN EN 10088)
- coupling	1.4301 (DIN EN 10088)
- indicator	PE-hard
- ball seal / seat	PTFE
- body seal	PTFE
plastic parts in actuator:	
- bearing	polyamide PA 12
- air connection	polyamide PA 6.6
- piston	polyacetal POM

11. Maintenance



Note!

The maintenance intervals are different depending on the application and must be determined by the operator performing regular checks.



Caution!

Apart from the replacement of wear parts, ball valves are nearly maintenance-free. During the operation observe that the ball valve is always switched into the open or closed final position. Intermediate positions can damage the seats and should be prevented. Depending on the operating conditions, the stem packing must be checked and re-sealed if necessary.



Caution!

Do not clean the valve with products containing abrasive or polishing substances.

- For valve maintenance SPX FLOW offers complete seal kits (see spare parts lists).
- Dismantling and installation of seals acc.to Service Instructions.
- Assembly and adjustment of turning actuator according to Service Instructions.
- The inner parts of the actuator are maintenance-free.
- Provide all seals with a thin layer of grease before their installation!



Caution!

The use of seal materials being compatible with the product, application and CIP liquids must be ensured. In case of doubt, contact your local SPX FLOW representative.



Caution!

If the product processed is sensitive to silicone, a suitable assembly grease must be used.

Recommendation:

APV assembly grease (silicone oil based)

0,75 kg/ tin - ref.-No. H147382; 000-70-01-019/93

60 g/ tube - ref.-No. H147381; 000-70-01-018/93

or

APV assembly grease (free from silicone oils)

0,6 kg/ tin - ref.-No. H147380; 000-70-01-017/93

60 g/ tube - ref.-No. H147379; 000-70-01-016/93



Less suited grease types can influence the function and life time.

12. Service Instructions BLV1 - H

Ball valve with manual operation without feedback

The position numbers refer to the illustration below.

12.1. Removal from the line system



Caution!

Liquid residue can be in the ball valve.



Caution!

1. Shut off connecting lines, depressurize line, and discharge it if possible.
2. Open the ball valve with the handle (11).
3. Release all body screws (6). Remove the upper body screw which is not passing through the body.
4. Swing out the body (4), move the ball (5) into closed position and remove it together with the seats.

12.2. Replacement of ball and ball seats

1. Dismantle the ball (5) together with the ball seats (3). Check ball for damage, and replace it if necessary.



Caution!

After dismantling, the ball is lying freely in the body. - In closed valve position, the ball can fall out of the body. Proceed carefully in order to prevent damage of the ball.

2. Insert the ball in closed position into the body and turn it with the handle into the open position. Add the new ball seats. Replace the body gaskets (2), and swing the ball valve back.
3. Tighten all body screws.

Pos. 1	flange end
Pos. 2*	body gasket
Pos. 3*	ball seat
Pos. 4	body
Pos. 5	ball
Pos. 6	body screw
Pos. 8	gland
Pos. 9	washer
Pos. 10	nut
Pos. 11	handle
Pos. 13	stem
Pos. 14*	stem seal
Pos. 15*	stem packing
Pos. 16	nut
Pos. 17	washer
Pos. *	parts of seal kit

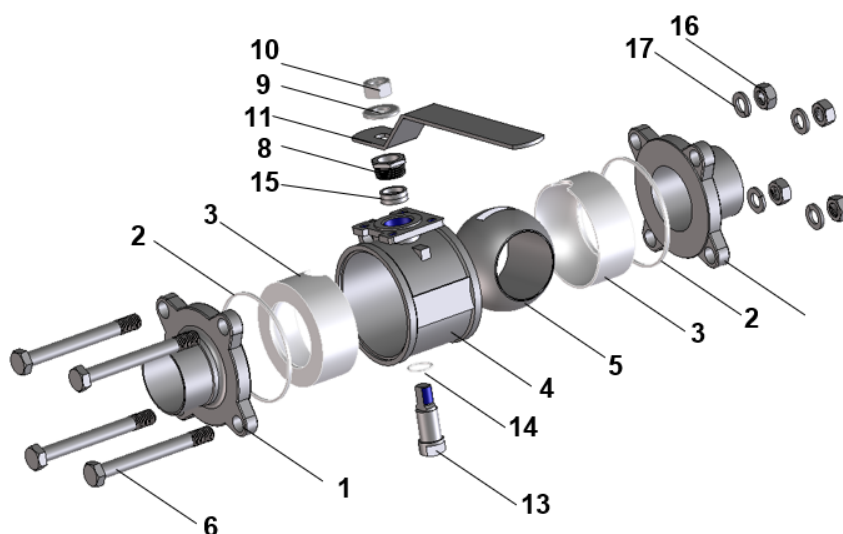

12. Service Instructions BLV1 - H

12.3. Replacement of stem seal

The position numbers refer to the illustration on page 17.

1. Dismantle the ball valve as described.
2. Take off the handle. For this purpose remove the nut (10) together with the washer (9).
3. Remove the gland (8) from the stem (13).
4. Remove the stem (13) with the stem seal (14) from the inside and the stem packings (15) from the outside of the body.
5. Install the new stem seal (14) with the stem (13) through the inside of the body and move it into the uppermost position.
6. Replace the stem packing (15) from the outside of the body.
7. Brace the stem packing with the gland (8).
Tightening torques, see 9.3.
8. Assemble the fitting in its previous position, see 12.2.
9. Re-tighten the gland (8) after 48 hours.

13. Service Instructions BLV1 - HL

Ball valve with manual operation and feedback

The position numbers refer to the illustration below.

13.1. Removal from the line system



Caution!

Liquid residue can be in the ball valve.



Caution!

1. Shut off connecting lines, depressurize line, and discharge it if possible.
2. Remove valve position indication.
3. For further dismantling see 12.1.2 - 12.1.4.

13.2. Removal of bracket with handle

1. Release and remove the fastening screws (1) and washers (2).
2. Detach the handle incl. bracket (3), the complete position indication (4) and the possibly existent adapter plate (5).
3. For further dismantling and replacement of the ball, ball seats and stem seal see 12.2. and 12.3.

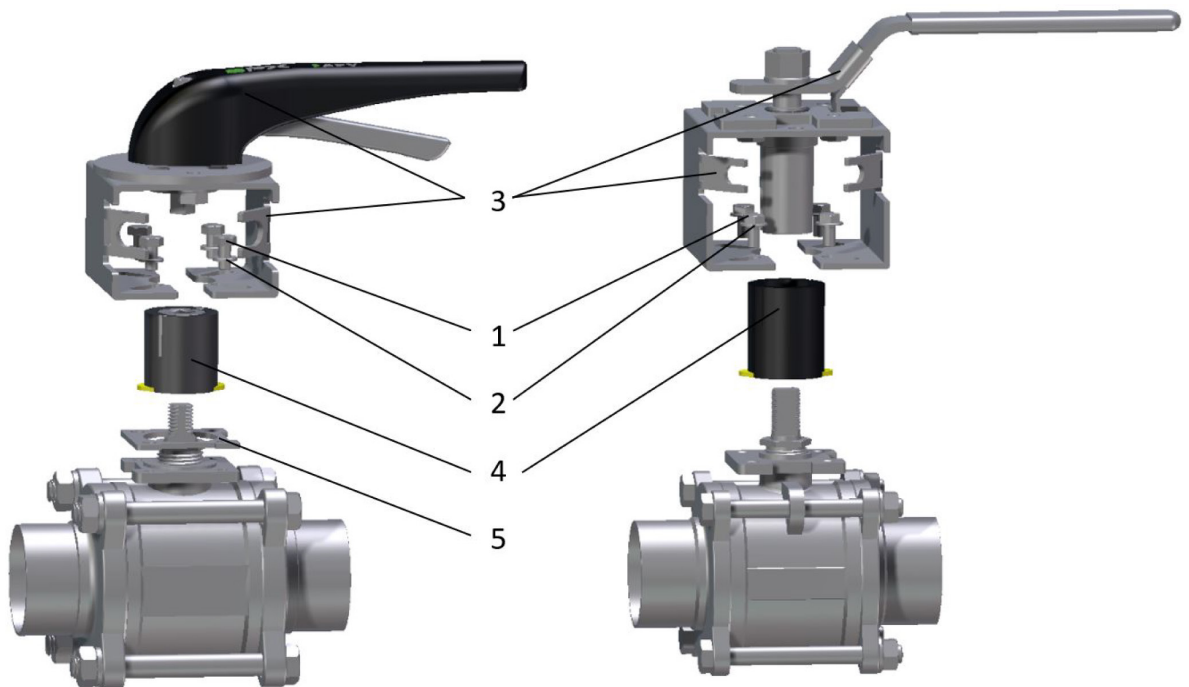

14. Service Instructions BLV1 - NC

Ball valve with actuator and control unit

The position numbers refer to the illustration below.

14.1. Removal from the line system



Caution!

Liquid residue can be in the ball valve.



Caution!

1. Shut off connecting lines, depressurize line, and discharge it if possible.



Caution!

2. Disconnect electric and pneumatic connections.
3. Remove valve position indication.
4. For further dismantling see 12.1.2 - 12.1.4.

14.2. Removal of bracket with turning actuator

1. Release and remove the fastening screws (1) and washers (2).
2. Detach the actuator incl. bracket (3), the complete position indication (4) and the possibly existent adapter plate (5).
3. For further dismantling and replacement of the ball, ball seats and stem seal see 12.2. and 12.3.

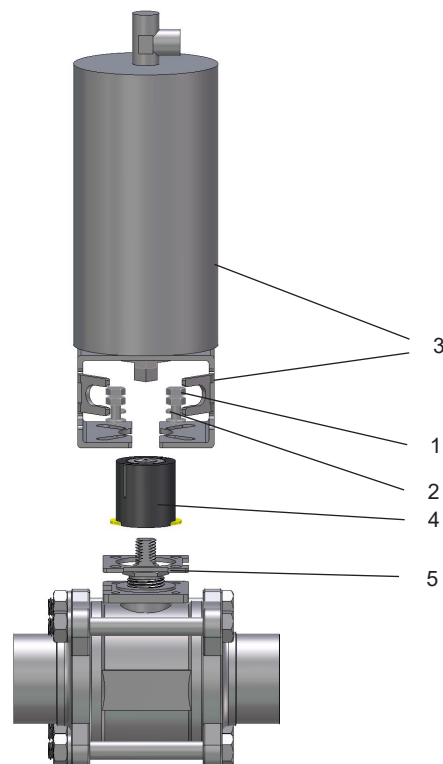

15. Spare Parts Lists

If damaged seals are exchanged, generally replace all seals.

Complete seal kits are available for valve service (see spare parts lists).

The reference numbers of the spare parts for the different valve designs and sizes are included in the attached spare parts drawings with corresponding lists.

Please indicate the following data to place an order for spare parts:

- number of required parts
- reference number
- designation

Data are subject to change.

Information contained in this document is subject to change without notice and does not represent a commitment on the part of SPX FLOW, Inc.. No part of this document may be reproduced or transmitted in any form or by any means, electronic or mechanical, including photocopying and recording, for any purpose, without the express written permission of SPX FLOW, Inc..

Spare Parts list

Ball Valve-BLV1-HL DN15, 1/2" - DN50, 2"

Date: 28.02.19 10.07.19 20.08.19 19.03.25

Name: R.Peters R.Peters R.Peters C.Keil

Reviewed:

SPX FLOW

Page 1 of 5

RN01-245-1

Date:

Name:

Reviewed:

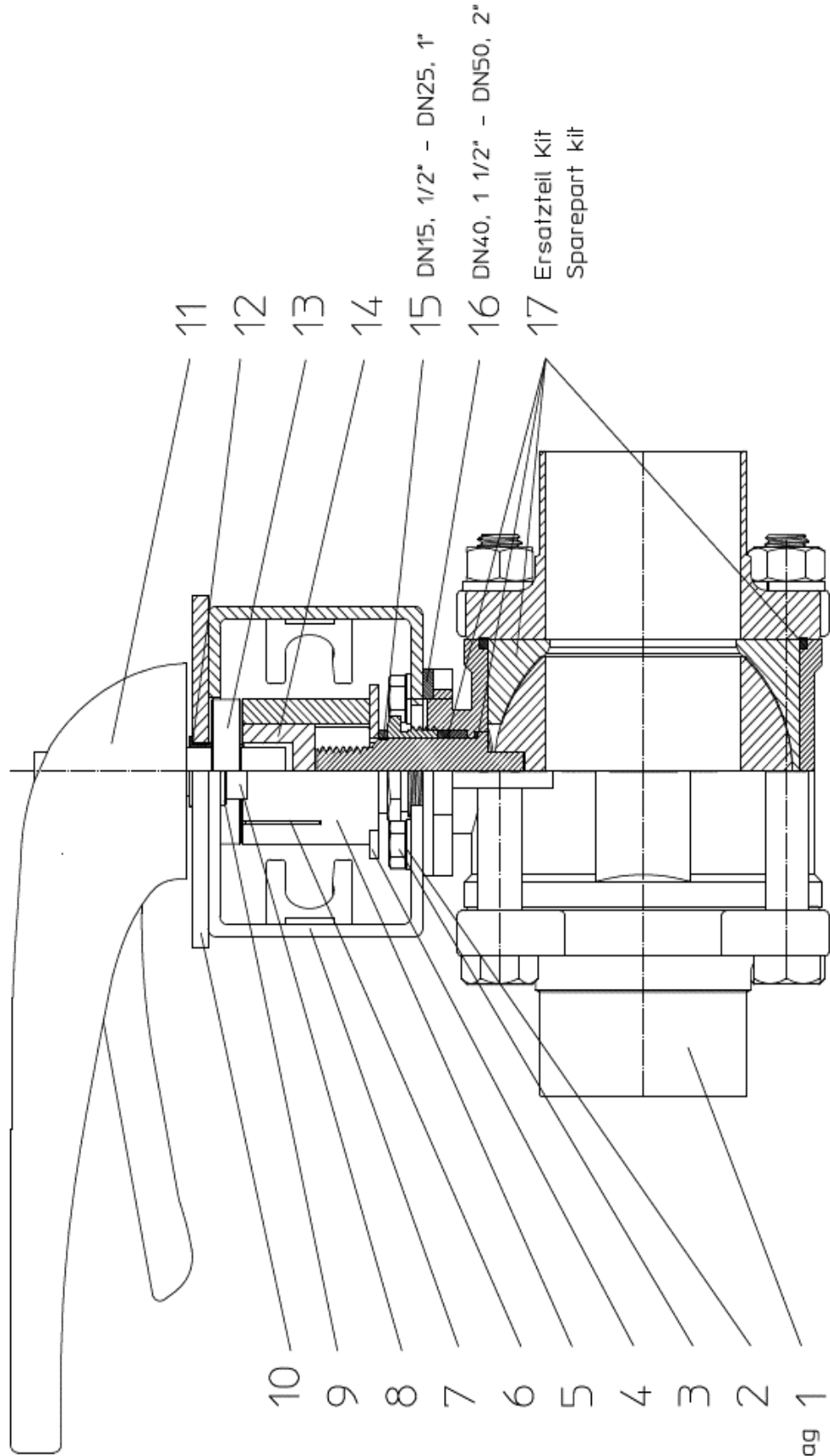

gemäß Auftrag 1
acc. order

- 10
- 9
- 8
- 7
- 6
- 5
- 4
- 3
- 2
- 1

- 11
- 12
- 13
- 14
- 15 DN15, 1/2" - DN25, 1"
- 16 DN40, 1 1/2" - DN50, 2"
- 17 Ersatzteil Kit
Sparepart kit

Information contained in this document is subject to change without notice and does not represent a commitment on the part of SPX FLOW, Inc.. No part of this document may be reproduced or transmitted in any form or by any means, electronic or mechanical, including photocopying and recording, for any purpose, without the express written permission of SPX FLOW, Inc..

Spare Parts list

Ball Valve-BLV1-HL DN15, 1/2" - DN50, 2"

Pos. Qty.		Description	Material	DN15		1/2"		3/4"		DN25		1"		
				Reference no. Part no.	Reference no. Part no.	Reference no. Part no.	Reference no. Part no.	Reference no. Part no.	Reference no. Part no.					
1	1	Ball valve BLV1-H-1+2S	1.4404 PTFE	30-15-434/57 H339740	30-15-416/57 H339724	30-15-435/57 H339741	30-15-417/57 H339725	30-15-436/57 H339742	30-15-418/57 H339726					
	1	Ball valve BLV1-H-1+2Clamp	1.4404 PTFE	30-15-453/57 H339748	30-15-425/57 H339732	30-15-444/57 H339749	30-15-426/57 H339733	30-15-445/57 H339750	30-15-427/57 H339734					
2	4	Washer	1.4301	67-01-014/13 A-5.3 H79587										
3	4	Hex. screw	1.4301	65-01-031/13 M5x10 H78734										
4	1	Visual Indicator	PE	08-29-095/93 H339637								08-29-096/93 H339638		
5	1	Indicator Holder	PE	08-52-229/92 H339633								08-52-230/92 H339634		
6	2	Indicator Pin	1.4305	67-15-031/13 H329220										
7	1	Bracket	1.4301	08-17-221/12 H339645								08-17-222/12 H339646		
8	2	Hex. screw	1.4301	65-01-074/15 M8x8 H334632										
9	2	Washer	1.4301	67-01-022/15 A-8.4 H79594										
10	1	Round plate	1.4301	08-58-026/17 H153637										
11	1	Manual actuating handle	PA6.6 30%GF	08-41-065/93 H15059										
12	1	Clips slide bearing	Iglidur	08-01-094/93 H169101										
13	1	Adapter manual BLV1	1.4301	08-48-093/17 H339648										
14	1	Adapter BLV1	1.4301	08-48-096/17 H339673								08-48-090/17 H339630		
15	1	Distance piece	PVC	08-48-032/93 H339643								08-48-033/93 H339644		

Information contained in this document is subject to change without notice and does not represent a commitment on the part of SPX FLOW, Inc.. No part of this document may be reproduced or transmitted in any form or by any means, electronic or mechanical, including photocopying and recording, for any purpose, without the express written permission of SPX FLOW, Inc..

Spare Parts list

Ball Valve-BLV1-HL DN15, 1/2" - DN50, 2"

		Date:	28.02.19	10.07.19			SPX FLOW	
		Name:	R.Peters	R.Peters				
		Reviewed:						
		Date:					Page 4 of 5	
		Name:					RN01-245-1	
		Reviewed:						
Pos.	Qty.	Description	Material	DN40	1 1/2"	DN50	2"	
				Reference no. Part no.	Reference no. Part no.	Reference no. Part no.	Reference no. Part no.	
1	1	Ball valve BLV1-H-1+2S	1.4404 PTFE	30-15-437/57 H339743	30-15-419/57 H339727	30-15-451/57 H339744	30-15-420/57 H339728	
	1	Ball valve BLV1-H-1+2Clamp	1.4404 PTFE	30-15-454/57 H339751	30-15-428/57 H339735	30-15-447/57 H339752	30-15-429/57 H339736	
2	4	Washer	1.4301	67-01-015/15 A6.4 H79589				
3	4	Hex. screw	1.4301	65-01-055/13 M6x12 H78750				
4	1	Visual Indicator	PE	08-29-097/93 H339639				
5	1	Indicator Holder	PE	08-52-231/92 H339635				
6	2	Indicator Pin	1.4305	67-15-031/13 H329220				
7	1	Bracket	1.4301	08-17-222/12 H339646				
8	2	Hex. screw	1.4301	65-01-074/15 M8x8 H334632				
9	2	Washer	1.4301	67-01-022/15 A-8,4 H79594				
10	1	Round plate	1.4301	08-58-026/17 H153637				
11	1	Manual actuating handle	PA6.6 30%GF	08-41-065/93 H15059				
12	1	Clips slide bearing	Iglidur	08-01-094/93 H169101				
13	1	Adapter manual BLV1	1.4301	08-48-093/17 H339648				
14	1	Adapter BLV1	1.4301	08-48-091/17 H339631				
15	1	Distance piece	PVC	-----				

Information contained in this document is subject to change without notice and does not represent a commitment on the part of SPX FLOW, Inc.. No part of this document may be reproduced or transmitted in any form or by any means, electronic or mechanical, including photocopying and recording, for any purpose, without the express written permission of SPX FLOW, Inc..

Spare Parts list

Ball Valve-BLV1-HL DN65, 2 1/2" - DN100, 4"

Date:	28.02.19	10.07.19	20.08.19	19.03.25
Name:	R.Peters	R.Peters	R.Peters	C.Keil
Reviewed:				

SPX FLOW

Page 1 of 2

RN01-245-3

Date:				
Name:				
Reviewed:				

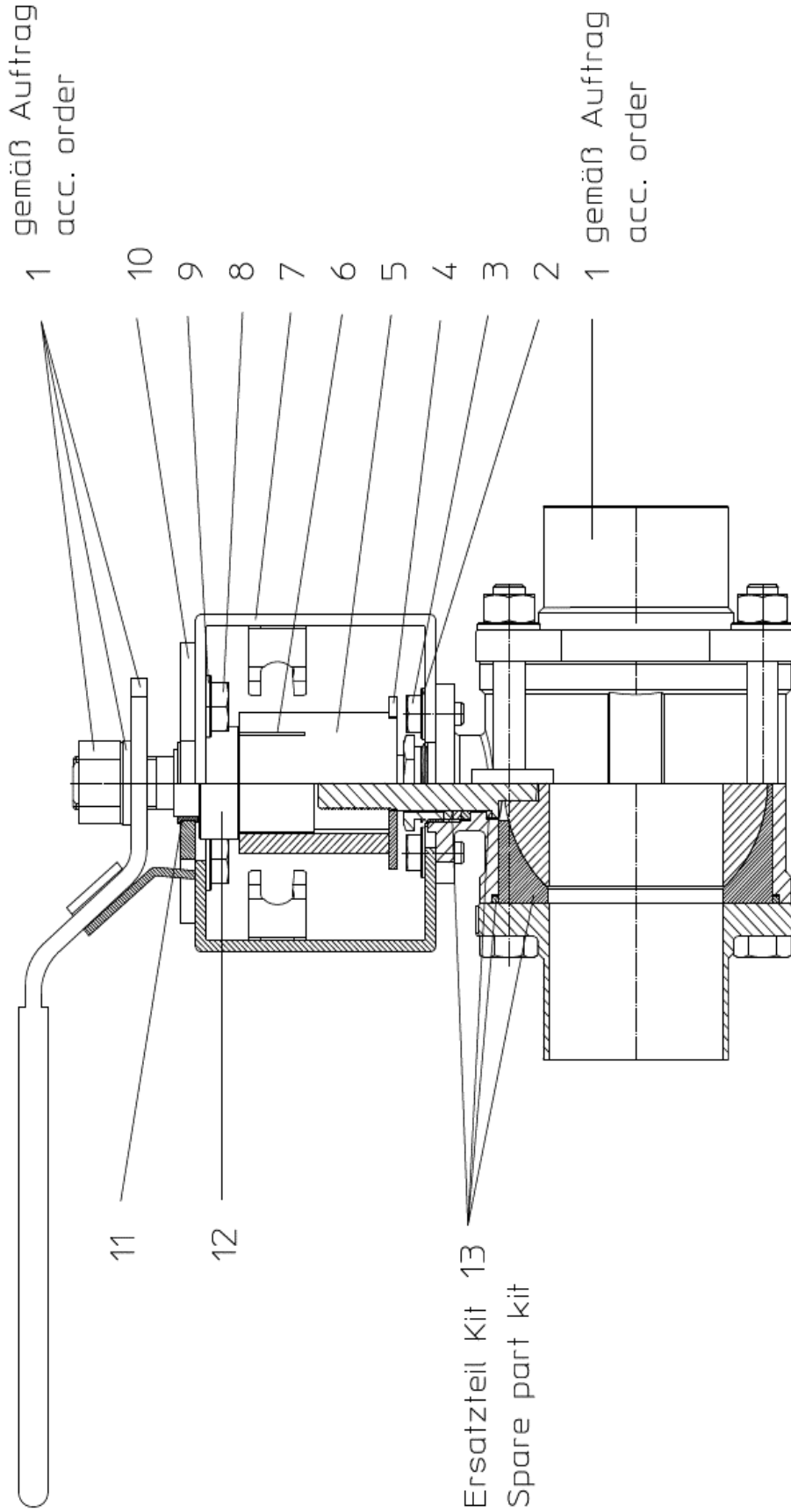

Information contained in this document is subject to change without notice and does not represent a commitment on the part of SPX FLOW, Inc.. No part of this document may be reproduced or transmitted in any form or by any means, electronic or mechanical, including photocopying and recording, for any purpose, without the express written permission of SPX FLOW, Inc..

Spare Parts list

Ball Valve-BLV1-NC DN15, 1/2" - DN100, 4"

Date:	28.02.19	10.07.19	20.08.19	19.03.25
Name:	R. Peters	R. Peters	R. Peters	C. Keil
Reviewed:				
Date:				
Name:				
Reviewed:				

SPX FLOW

Page 1 of 7

RN01-245-2

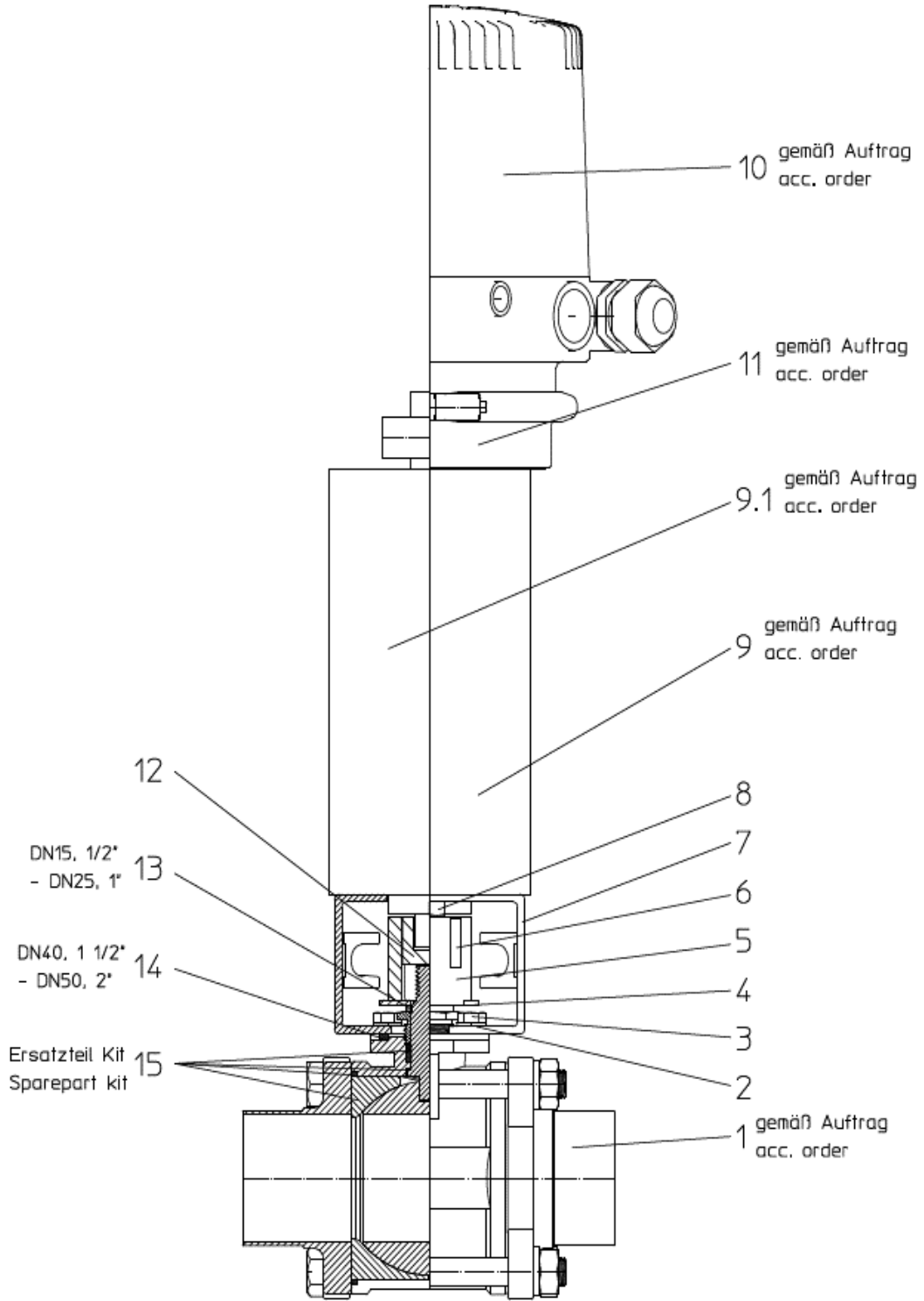

10 gemäß Auftrag acc. order

11 gemäß Auftrag acc. order

9.1 gemäß Auftrag acc. order

9 gemäß Auftrag acc. order

12
DN15, 1/2"
- DN25, 1"

13
DN40, 1 1/2"
- DN50, 2"

14
Ersatzteil Kit
Sparepart kit

1 gemäß Auftrag acc. order

Information contained in this document is subject to change without notice and does not represent a commitment on the part of SPX FLOW, Inc.. No part of this document may be reproduced or transmitted in any form or by any means, electronic or mechanical, including photocopying and recording, for any purpose, without the express written permission of SPX FLOW, Inc..

Spare Parts list

Ball Valve-BLV1-NC DN15, 1/2" - DN100, 4"

		Date:	28.02.19	10.07.19	20.08.19	19.03.25	SPX FLOW		
		Name:	R.Peters	R.Peters	R.Peters	C.Keil			
		Reviewed:							
		Date:					Page	2 of 7	
		Name:					RN01-245-2		
		Reviewed:							
Pos.	Qty.	Description	Material	DN15	1/2"	DN20	3/4"	DN25	1"
		Reference no.	Reference no.	Reference no.	Reference no.	Reference no.	Reference no.	Reference no.	Reference no.
		Part no.	Part no.	Part no.	Part no.	Part no.	Part no.	Part no.	Part no.
1	1	Ball valve BLV1-H-1+2S	1.4404 PTFE	30-15-434/57 H339740	30-15-416/57 H339724	30-15-435/57 H339741	30-15-417/57 H339725	30-15-436/57 H339742	30-15-418/57 H339726
		Reference no.	Reference no.	Reference no.	Reference no.	Reference no.	Reference no.	Reference no.	Reference no.
		Part no.	Part no.	Part no.	Part no.	Part no.	Part no.	Part no.	Part no.
1	1	Ball valve BLV1-H-1+2Clamp	1.4404 PTFE	30-15-453/57 H339748	30-15-425/57 H339732	30-15-444/57 H339749	30-15-426/57 H339733	30-15-445/57 H339750	30-15-427/57 H339734
2	4	Washer	1.4301	67-01-014/13 A-5.3 H79587					
3	4	Hex. screw	1.4301	65-01-031/13 M5x10 H78734					
4	1	Visual Indicator	PE	08-29-095/93 H339637	08-29-096/93 H339638				
5	1	Indicator Holder	PE	08-52-229/92 H339633	08-52-230/92 H339634				
6	2	Indicator Pin	1.4305	67-15-031/13 H329220					
7	1	Bracket	1.4301	08-17-221/12 H339645	08-17-222/12 H339646				
8	2	Hex. screw	1.4301	65-01-080/15 M8x12 H78770					
9	2	Actuator	1.4301	15-31-055/17 H105500					
9.1	1	Actuator prepared for CU	1.4301	15-37-070/17 H315055					
10	1	Control Unit CU4-T-Direct Connect	PA6.6 GF30 schwarz	08-45-101/93 H320461					
10.1	1	Control Unit CU4-T-ASI-standard	PA6.6 GF30 schwarz	08-45-251/93 H324674					
10.2	1	Control Unit CU4-T-ASI-extended	PA6.6 GF30 schwarz	08-45-111/93 H320468					
11	1	CU4-T-Adapter	PA6.6 GF30 schwarz	08-48-601/93 H320475					
12	1	Adapter BLV1	1.4301	08-48-096/17 H339673	08-48-090/17 H339630				

Information contained in this document is subject to change without notice and does not represent a commitment on the part of SPX FLOW, Inc.. No part of this document may be reproduced or transmitted in any form or by any means, electronic or mechanical, including photocopying and recording, for any purpose, without the express written permission of SPX FLOW, Inc..

Spare Parts list

Ball Valve-BLV1-NC DN15, 1/2" - DN100, 4"

		Date:	28.02.19	10.07.19	20.08.19	19.03.25	SPX FLOW			
		Name:	R.Peters	R.Peters	R.Peters	C.Keil				
		Reviewed:					Page 4 of 7			
		Date:					RN01-245-2			
		Name:								
		Reviewed:								
Pos.	Qty.	Description	Material	DN40	1 1/2"	DN50	2"	DN65	Reference no. Part no.	Reference no. Part no.
1	1	Ball valve BLV1-H-1+2S	1.4404 PTFE	30-15-437/57 H339743	30-15-419/57 H339727	30-15-451/57 H339744	30-15-420/57 H339728	30-15-439/57 H339745	30-15-421/57 H339729	30-15-430/57 H339737
1	1	Ball valve BLV1-H-1+2Clamp	1.4404 PTFE	30-15-454/57 H339751	30-15-428/57 H339735	30-15-447/57 H339752	30-15-429/57 H339736	30-15-448/57 H339753	30-15-430/57 H339737	30-15-430/57 H339737
2	4	Washer	1.4301	67-01-015/15 A6.4 H79589		67-01-022/15 A8.4 H79594		67-01-022/15 A8.4 H79594		67-01-022/15 A8.4 H79594
3	4	Hex. screw	1.4301	65-01-055/13 M6x12 H78750		65-01-081/15 M8x16 H78772		65-01-081/15 M8x16 H78772		65-01-081/15 M8x16 H78772
4	1	Visual Indicator	PE	08-29-097/93 H339639		08-29-098/93 H339640		08-29-098/93 H339640		08-29-098/93 H339640
5	1	Indicator Holder	PE	08-52-231/92 H339635		08-52-232/92 H339636		08-52-232/92 H339636		08-52-232/92 H339636
6	2	Indicator Pin	1.4305	67-15-031/13 H329220						
7	1	Bracket	1.4301	08-17-222/12 H339646		08-17-223/12 H339647		08-17-223/12 H339647		08-17-223/12 H339647
8	2	Hex. screw	1.4301	65-01-080/15 M8x12 H78770		67-01-129/15 M10x14 H78805		67-01-129/15 M10x14 H78805		67-01-129/15 M10x14 H78805
9	2	Actuator	1.4301	15-31-055/17 H105500		15-31-057/17 H105502		15-31-057/17 H105502		15-31-057/17 H105502
9.1	1	Actuator prepared for CU	1.4301	15-37-070/17 H315055		15-37-106/17 H128942		15-37-106/17 H128942		15-37-106/17 H128942
10	1	Control Unit CU4-T-Direct Connect	PA6.6 GF30 schwarz	08-45-101/93 H320461		08-45-101/93 H320461		08-45-101/93 H320461		08-45-101/93 H320461
10.1	1	Control Unit CU4-T-ASI-standard	PA6.6 GF30 schwarz	08-45-251/93 H324674		08-45-251/93 H324674		08-45-251/93 H324674		08-45-251/93 H324674
10.2	1	Control Unit CU4-T-ASI-extended	PA6.6 GF30 schwarz	08-45-111/93 H320468		08-45-111/93 H320468		08-45-111/93 H320468		08-45-111/93 H320468
11	1	CU4-T-Adapter	PA6.6 GF30 schwarz	08-48-601/93 H320475		08-48-601/93 H320475		08-48-601/93 H320475		08-48-601/93 H320475
12	1	Adapter BLV1	1.4301	08-48-091/17 H339631		08-48-091/17 H339631		08-48-091/17 H339631		08-48-091/17 H339631

Information contained in this document is subject to change without notice and does not represent a commitment on the part of SPX FLOW, Inc.. No part of this document may be reproduced or transmitted in any form or by any means, electronic or mechanical, including photocopying and recording, for any purpose, without the express written permission of SPX FLOW, Inc..

Spare Parts list

Ball Valve-BLV1-NC DN15, 1/2" - DN100, 4"

		Date:	28.02.19	10.07.19	20.08.19	19.03.25	SPX FLOW	
		Name:	R.Peters	R.Peters	R.Peters	C.Keil		
		Reviewed:						
		Date:					Page	6 of 7
		Name:					RN01-245-2	
		Reviewed:						
Pos.	Qty.	Description	Material	DN80	3"	DN100	4"	
				Reference no.	Reference no.	Reference no.	Reference no.	
				Part no.	Part no.	Part no.	Part no.	
1	1	Ball valve BLV1-H-1+2S	1.4404 PTFE	30-15-440/57 H339746	30-15-422/57 H339730	30-15-452/57 H339747	30-15-423/57 H339731	
	1	Ball valve BLV1-H-1+2Clamp	1.4404 PTFE	30-15-449/57 H339754	30-15-431/57 H339738	30-15-450/57 H339755	30-15-432/57 H339739	
2	4	Washer	1.4301	67-01-022/15 A8,4 H79594		67-01-013/15 A-10,5 H79586		
3	4	Hex. screw	1.4301	65-01-081/15 M8x16 H78772		65-01-132/15 M10x20 H78809		
4	1	Visual Indicator	PE	08-29-098/93 H339640		08-29-099/93 H339778		
5	1	Indicator Holder	PE	08-52-232/92 H339636		08-52-239/12 H339777		
6	2	Indicator Pin	1.4305	67-15-031/13 H329220				
7	1	Bracket	1.4301	08-17-223/12 H339647				
8	2	Hex. screw	1.4301	67-01-129/15 M10x14 H78805				
9	2	Actuator	1.4301	15-31-057/17 H105502		15-31-923/17 H32589		
9.1	1	Actuator prepared for CU	1.4301	15-37-106/17 H128942		15-37-103/17 H134034		
10	1	Control Unit CU4-T-Direct Connect	PA6.6 GF30 schwarz	08-45-101/93 H320461				
10.1	1	Control Unit CU4-T-ASI-standard	PA6.6 GF30 schwarz	08-45-251/93 H324674				
10.2	1	Control Unit CU4-T-ASI-extended	PA6.6 GF30 schwarz	08-45-111/93 H320468				
11	1	CU4-T-Adapter	PA6.6 GF30 schwarz	08-48-611/93 H321987				
12	1	Adapter BLV1	1.4301	08-48-092/17 H339632		08-48-098/17 H339776		

Information contained in this document is subject to change without notice and does not represent a commitment on the part of SPX FLOW, Inc.. No part of this document may be reproduced or transmitted in any form or by any means, electronic or mechanical, including photocopying and recording, for any purpose, without the express written permission of SPX FLOW, Inc..

Spare parts list

Actuator K080, K125, K180 spring/air

Date:	22.11.12	12.03.14	SPX FLOW	
Name:	Trytko	Trytko		
Reviewed:	Goebel			
Date:			Page	1 of 2
Name:				
Reviewed:				RN 01.073

DRAT K080

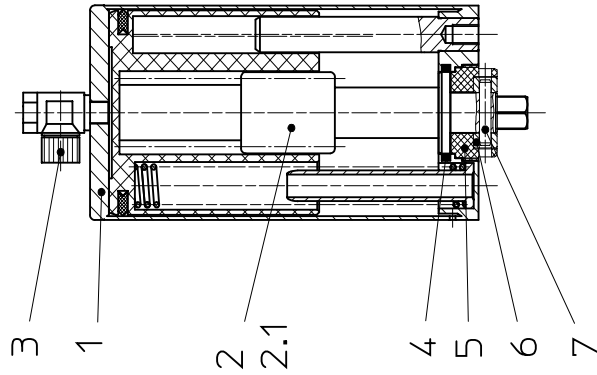

DRAT K125

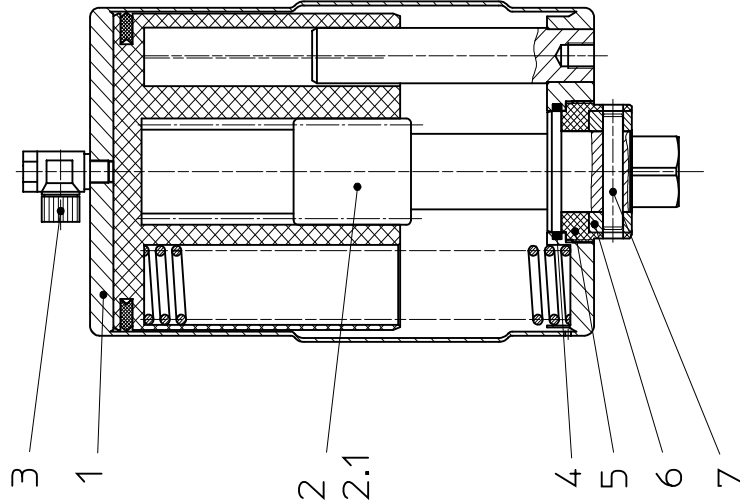

DRAT K180

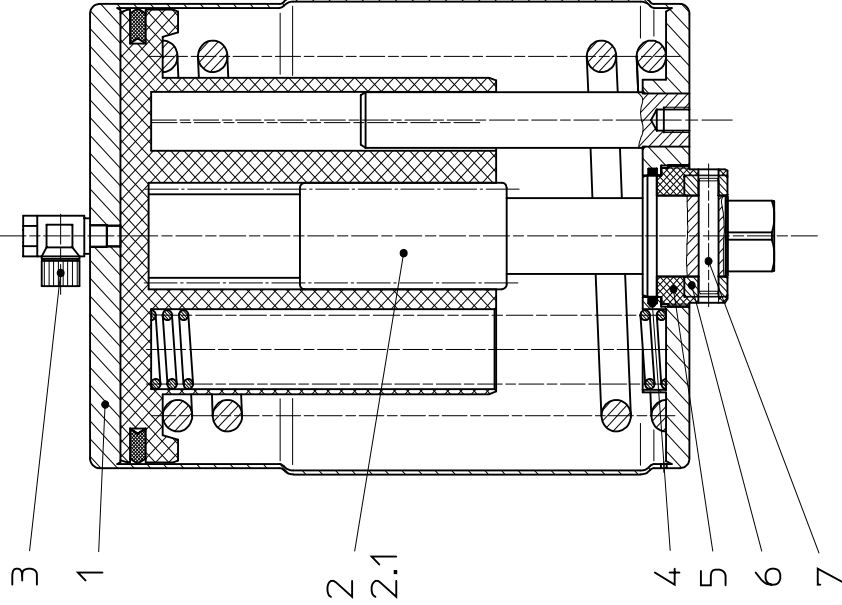

Information contained in this document is subject to change without notice and does not represent a commitment on the part of SPX FLOW, Inc.. No part of this document may be reproduced or transmitted in any form or by any means, electronic or mechanical, including photocopying and recording, for any purpose, without the express written permission of SPX FLOW, Inc..

Spare parts list

Actuator K080, K125, K180 spring/air

Pos. Item	Quantity	Description	Material	K080		K125		K180		Reference no. Part no.	Reference no. Part no.	Reference no. Part no.
				Reference no. Part no.	Reference no. Part no.	Reference no. Part no.	Reference no. Part no.					
1	1	Actuator complete	1.4301 satin finish	15-31-055/17 H105500	15-31-057/17 H105502	15-31-923/17 H32589						
1	1	Actuator complete	1.4301 polished	15-31-055/13 H135919	15-31-057/13 H131940	15-31-923/13 H32588						
1	1	Actuator welded	1.4301	15-31-054/17 H105499	15-31-056/17 H105501	15-31-922/17 H32587						
2	1	Shaft complete with bearing	1.4301	15-24-021/13 H31494	15-24-031/13 H31502	15-24-033/13 H31504						
2.1	1	Shaft	1.4301	15-24-020/13 H31493	15-24-030/13 H31501	15-24-032/13 H31503						
3	1	Elbow union G1/8" slewable	polyamide/ glass fibre	08-63-221/93 H16371								
4	1	O-ring	NBR	58-06-130/83 32,2x3 H76965								
4	1	O-ring	FPM		58-06-222/73 49,5x3 H77000							
5	1	Bearing for actuator	POM	15-28-002/34 H31673								
5	1	Bearing for actuator	PA12		15-28-009/63 H31684							
6	1	Adjust ring	1.4301	67-08-007/13 H79757	67-08-008/13 H79758							
7	1	Cyl. pin	DIN EN ISO 8740-V2A	67-15-035/13 5x26 H79916	67-15-036/13 8x45 H79917							

Information contained in this document is subject to change without notice and does not represent a commitment on the part of SPX FLOW, Inc.. No part of this document may be reproduced or transmitted in any form or by any means, electronic or mechanical, including photocopying and recording, for any purpose, without the express written permission of SPX FLOW, Inc..

Spare parts list

Actuator K080, K125, K180 spring/air for control unit

Date:	28.03.13	08.05.14	07.02.25	SPX FLOW	
Name:	Trytko	Trytko	C.Keil		
Reviewed:					
Date:				Page	1 of 2
Name:				RN 01.076	
Reviewed:					

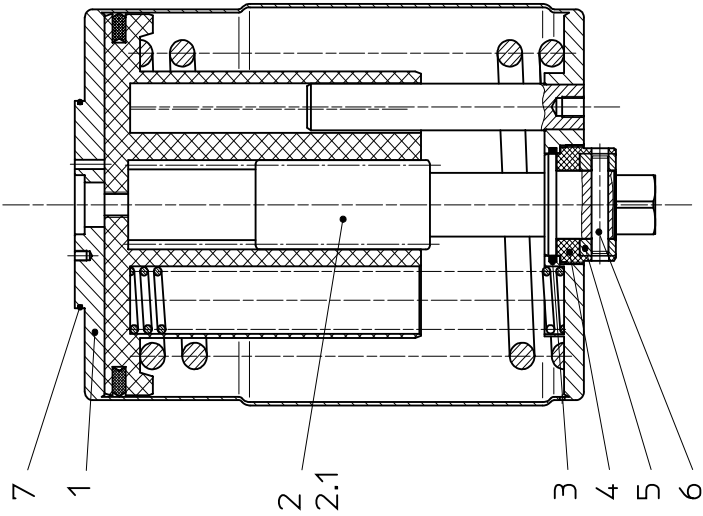
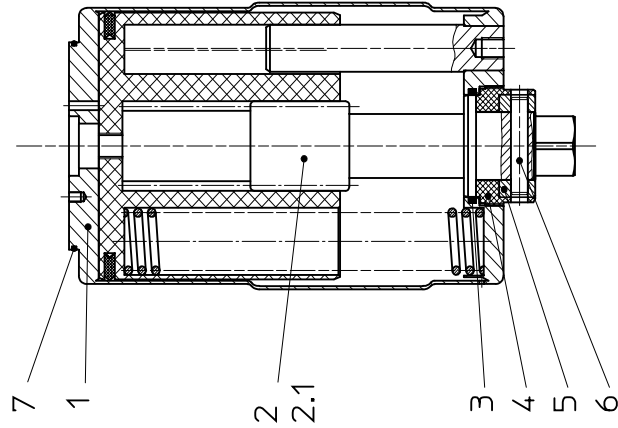
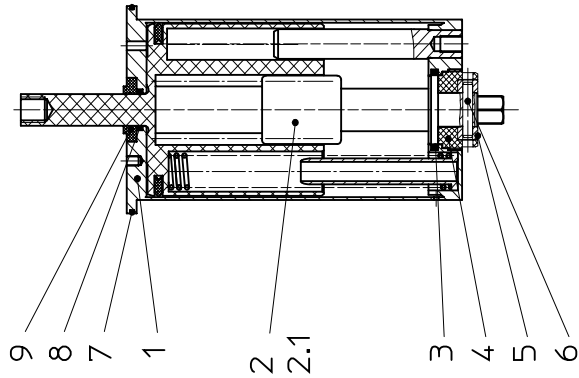

Information contained in this document is subject to change without notice and does not represent a commitment on the part of SPX FLOW, Inc.. No part of this document may be reproduced or transmitted in any form or by any means, electronic or mechanical, including photocopying and recording, for any purpose, without the express written permission of SPX FLOW, Inc..

Spare parts list

Actuator K080, K125, K180 spring/air for control unit

Pos. Item	Quantity	Description	Material	K080		K125		K180		SPX FLOW		
				Reference no. Part no.	Reference no. Part no.	Reference no. Part no.	Reference no. Part no.	Reference no. Part no.	Reference no. Part no.	Reference no. Part no.		
1	1	Actuator complete	1.4301 satin finish	15-37-070/17 H315055	15-37-106/17 H128942	15-37-103/17 H134034						
1	1	Actuator complete	1.4301 polished	15-37-070/13 H316969	15-37-106/13 H327700	15-37-103/13 H328071						
1	1	Actuator welded	1.4301	15-37-071/17 H123936	15-37-105/17 H128940	15-37-104/17 H134503						
2	1	Shaft complete with bearing	1.4301	15-24-021/13 H31494	15-24-031/13 H31502	15-24-033/13 H31504						
2.1	1	Shaft	1.4301	15-24-020/13 H31493	15-24-030/13 H31501	15-24-032/13 H31503						
3	1	O-ring	NBR	58-06-130/83 H76965								
	1	O-ring	FPM		58-06-222/73 H77000							
	1	Bearing for actuator	POM	15-28-002/34 H31673								
4	1	Bearing for actuator	PA12		15-28-009/63 H31684							
5	1	Adjust ring	1.4301	67-08-007/13 H79757	67-08-008/13 H79758							
6	1	Cyl. pin	1.4305	67-15-035/13 5x26 H79916	67-15-036/13 8x45 H79917							
7	1	O-ring	NBR		58-06-426/83 H143352							
8	1	O-ring	NBR	58-06-052/83 H107914								
9	1	Thrust ring turning actuator	Hostaform	08-48-117/53 H105080								

APV BLV1

BALL VALVE

SPXFLOW[®]

SPX FLOW

Design Center

Gottlieb-Daimler-Straße 13
D-59439 Holzwickede, Germany
P: (+49) (0) 2301-9186-0
F: (+49) (0) 2301-9186-300

SPX FLOW

Production

Stanisława Jana Rolbieskiego 2
PL - 85-862 Bydgoszcz, Poland
P: (+48) 52 566 76 00
F: (+48) 52 525 99 09

SPX FLOW reserves the right to incorporate the latest design and material changes without notice or obligation.

Design features, materials of construction and dimensional data, as described in this manual, are provided for your information only and should not be relied upon unless confirmed in writing. Please contact your local sales representative for product availability in your region.

For more information visit www.spxflow.com.

ISSUED 08/2021 - Original Manual

COPYRIGHT ©2021 SPX FLOW, Inc..