

Double-acting (Threaded Body)
SWING / PULL CLAMP

Max. Capacity: 365 lbs. Clamping Force (with 1.06" lg. arm) at 5,000 PSI Max.

110004 - Left Hand

110005 - Right Hand

110006 - Straight Pull

The piston rod U-cup seal (Item 10) can be easily twisted if installed incorrectly. Before installing the piston rod (Item 13) lubricate the rod and all seals with hydraulic oil. Install the rod with light pressure and a twisting motion as the seal is first contacted.

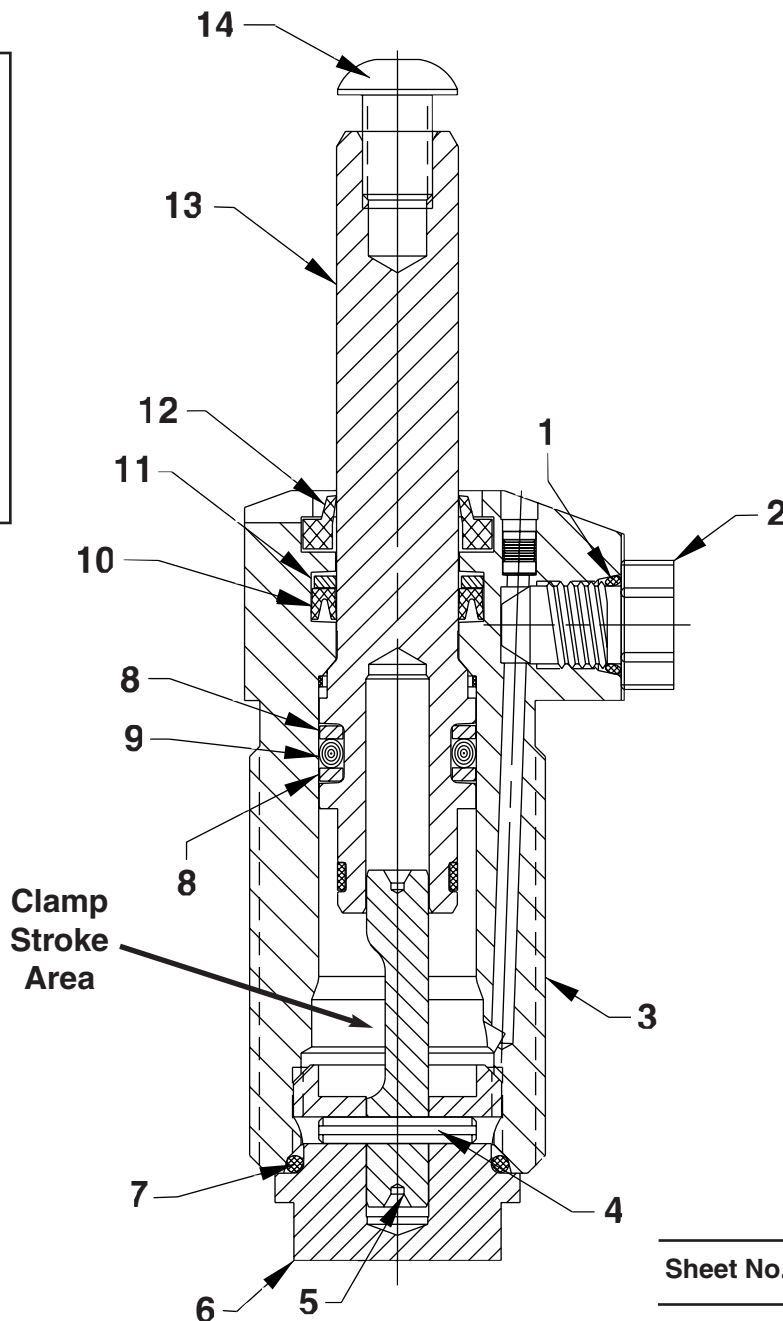

Parts List, Form No. 101870, Back sheet 1 of 1

Item No.	Part No.	No. Req'd	Description
1	15189	2	O-Ring (.36 x .23 Nitrile)
2	252531	2	Fitting, Plug (5/16-24 Plastic)
3	351401	1	Body, Threaded w/Plug
4	252877	1	Pin, Spring (.09 x .56)
5	351397	1	Cam, Left Hand (Left Hand† 90° for 110004)
	351398	1	Cam, Right Hand (Right Hand† 90° for 110005)
	351399	1	Cam, Straight (Straight Pull for 110006)
6	351432	1	Cap, End DA (Torque to 450/470 in. lbs.)
7	*10527	1	O-Ring (.81 x .64 Nitrile)
8	*252515	2	Washer, Backup (.49 x .39)
9	*252505	1	O-Ring (.56 x .38 URE)
10	*252473	1	U-Cup (.62 x .43 x .09 H)
11	*252479	1	Washer, Backup (.61 x .43 x .04)
12	*252453	1	Wiper, Rod (.69 x .44 URE)
13	351400	1	Rod, Piston
14	251910	1	Screw, Button HD (1/4-20 x 3/8; Torque to 80/100 in. lbs.)

NOTE: Grease roller in piston rod (Item #13) and cam with a light coating of CDM Extreme Pressure Lube #3.

Part numbers marked with an asterisk (*) are contained in Repair Kit No. 300954.

†Right hand rotation is clockwise rotation when viewed from the piston rod end.

Left hand is counterclockwise rotation. To reverse clamp rotation, order the appropriate rotating cam.

Note: Shaded areas reflect last revision(s) made to this form.

Refer to any operating instructions included with this product for detailed information about operation, testing, disassembly, reassembly, and preventive maintenance.

Items found in this parts list have been carefully tested and selected. **Therefore: Use only genuine Hytec replacement parts!**

Additional questions can be directed to our Technical Services Department.