

>Lightnin®



COMPACT SERIES

Medium Torque Top Entry Mixers



SPXFLOW®

COMPACT SERIES FROM LIGHTNIN



A World Leader in Industrial Mixing since 1923, Lightnin has over 100 years of unrivaled experience in industrial mixing technology, process knowledge, and technological innovation.



Target Markets:

WATER & WASTE WATER



CHEMICAL PROCESSING



MINING, POWER + ENERGY SLURRY PROCESSES



The Mining and Water markets will predominantly use open tank mixers. The Compact Series has feet integral to the casting for the gearbox, adapter plates can be provided to fit your existing structures to help you swap out older equipment.

Additionally, we have reduced the number of parts in the gearbox when compared with the Series 10, this reduction in complexity also helps simplify and reduces maintenance time.

A single mechanical seal is available as well as a simple lip seal, which will be accommodated in a simple low height pedestal. These are suitable for use in the general Chemical Process applications.

The Compact Series Mixers by Lightnin offers great value. It has the same high mixing performance as all of our mixers, but at an affordable price.

With its simplified design, the Compact Series benefits from a reduced foot print when you compare the gearbox against our other purpose built agitator gearboxes for equal torque capacity. This reduced foot print makes the unit easier to install and reduces the weight on your support structure. Additionally, the design can accommodate either a double or triple reduction without changing the casting, so no change of foot print for change of speed in the same gearbox size. Reduced weight and loads can help save money on support infrastructure.

Your mixing performance remains unchanged as you still have access to the key Lightnin impellers that serve the target markets.

Product Specifications

Power:	0 kW to 55 kW
Speed:	13 rpm to 155 rpm (not all speeds at all powers)
Motor:	IEC or NEMA, 3 phase, 50 or 60 Hz, Flange mount, IE3, IP54 or higher, 380 VAC, 400 VAC, or 230/460 VAC
Gearbox:	SGI Casting, Integral Cast feet for bolting, Cast motor pedestal, Min 30,000 hours L10 Bearing Life, AGMA Q10 Gears, Double or Triple Reduction, Parallel Drive, True Dry Well cast into the gearbox
Output Shafts:	Ø40mm to Ø150 mm (Ø1-1/2" to Ø5-1/2"), C/S, 304 or 316, available with 3 mm (1/8") Soft Natural Rubber covering or Polish 0.5 µm Ra (20 µin Ra), In-tank couplings available
Impellers:	A510, A200, A320, R100 or CleanEdge. Impellers can be welded or keyed for adjustability

OPTIONS

Mechanical Seals:	FV to 87 psi (6 bar), -4°F to +248°F (-20°C to +120°C), Single Mechanical Seal, SiCvC, Viton elastomers
Lip Seal:	For a degree of ingress protection for the tank contents or odor control
Steady Bearings:	Tripod or Flange



A510 (Core Impeller Technology)

Low blade solidity hydrofoil, recommended for low viscosity blending and solid suspension applications

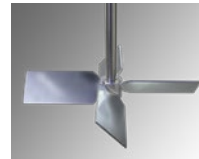

A200

Recommended for low to medium viscosity blending and solids suspension applications

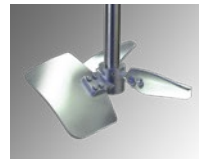

A320 (Core Impeller Technology)

High solidity hydrofoil design recommended for high viscosity blending applications

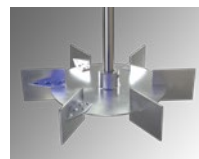

R100 (Rushton Turbine)

Recommended for high shear mixing applications



Clean Edge

Specifically designed as a rag-free, non-stringing axial flow impeller for the Water Industry

Compact Series Product Description

The Compact Series is a much **simplified construction**. The gearbox is a **Lightnin design** and **built by Lightnin**, so you still benefit from a **True Dry Well** – a dry well that is cast integrally into the gearbox, and is not an optional component that has an O-ring seal at the base as offered in some gearboxes. True Dry Well construction is critically important in the water industry and other industries where the operator wants to ensure that gearbox lubricant does not seep past shaft seals into the drinking water or other products. Shaft oil seals on agitator drives can easily become worn due to shaft deflection or perish in certain conditions such that they can no longer perform their critical function – keeping the lubricant in the gearbox.

With its design the Compact Series benefits from a reduced foot print when you compare the gearbox against our other **purpose built agitator gearboxes** for equal torque capacity. This reduced foot print makes the unit easier to install and reduces the weight on your support structure. We've also made the design accommodate either a double or triple reduction without changing the casting, so no change of foot print for change of speed in the same gearbox size. Reduced weight and loads can help save cost on support infrastructure.

The simple construction of the parallel shafts of the gearbox makes the Compact Series gearbox very quiet and it runs smoothly. The temperature rise of the gearbox lubrication is also very low for gearboxes of this size, which helps for longer lubricant life when compared to other drive configurations. You don't need to re-grease bearings with our design; the bearings are lubricated by the gear oil. One of our innovations in this area reduces the gear deflection due to the bending load, which reduces the wear on the gears and helps provide that low noise and smooth running.



Local Legislation requirements can be met using the Compact Series; it is designed for global use. The equipment is designed for OSHA, CE including ATEX, and global Efficiency standards for motors. We'll ensure that the motor fitted is the one that meets your voltage, frequency and efficiency standard – whether you are in South America, South Africa, China, Australia or Europe. **IE3 is the minimum efficiency for safe area motors on the Compact Series.**



COMPACT SERIES INTERNALS

Triple Reduction and Dry Well

Compact Series Product Features

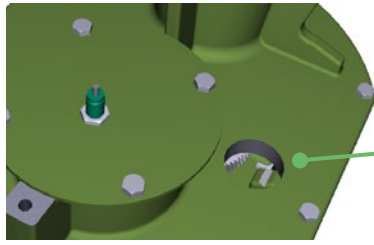

Large Oil Fill & Visible Level Marking

Easier oil filling with large opening and visible fill mark so you don't need to keep stopping and using a dip stick to measure fill.

IEC or NEMA Electric Motor

Suits Regional Voltage Requirements (380, 400, etc.)
Flange mounted, V1
IE3 Efficiency
Safe area or ATEX (up to 2G IIC T4) or XP
Unit can be provided without motor (requires shipping plate to protect the gearbox)

Integral Motor Pedestal

Suits IEC or NEMA Frame Flange motors. Has protective moisture trap to guard against moisture ingress. High strength and low deflection as it is cast with the gearbox top cover plate.

Shaft Speed Sensor (optional)

Intrinsically Safe shaft rotation sensor fitting location established. Sensor comes with 1.8 m lead for connection to customer's controls.

Bearing Housings

Rigid cast bearing locations minimize gearbox deflection helping to improve bearing and gear life.

High Speed Gear & Bearing Assembly

Offers high ratio flexibility to offer multiple output ratios.

Gearbox Housing

Single piece gearbox casting can accommodate double or triple reduction ratios without changing size. Split line of the gearbox is at the top, well above the oil level, this helps prevent oil leakage.

High Quality Helical Gears

Designed to AGMA Quality 10. The gear quality and the innovative design lead to a very low noise gearbox. Gear deflection is minimized by our patented design which extends the life of the gears and the bearings.

High Strength Shaft Coupling

Our high strength can shaft coupling can accommodate very high bending moments, making the Compact Series very strong for its size.

Flange & Pedestal Mounting (optional)

Cast mounting pedestals are available to elevate the gearbox if required, this can help customers drain oil directly into a 20 L (5 gal) bucket.

Additionally, the pedestal can accommodate our **NEW SPX FLOW mechanical seal**, or our face seals.

Flanges are available in ANSI, DIN, or HG/T dimensions. Where provided flanges incorporate a shaft catcher to hold the shaft during maintenance where the gearbox is removed.

True Dry Well

The True Dry Well is cast into the gearbox housing, removing lower shaft bearing shields, labyrinths and lips seals that can perish or wear; this effectively eliminates the risk of oil leakage down the mixer shaft into customers' product.

Direct Mounting

Cast into the gearbox housing are feet for direct mounting to beams or other superstructure.

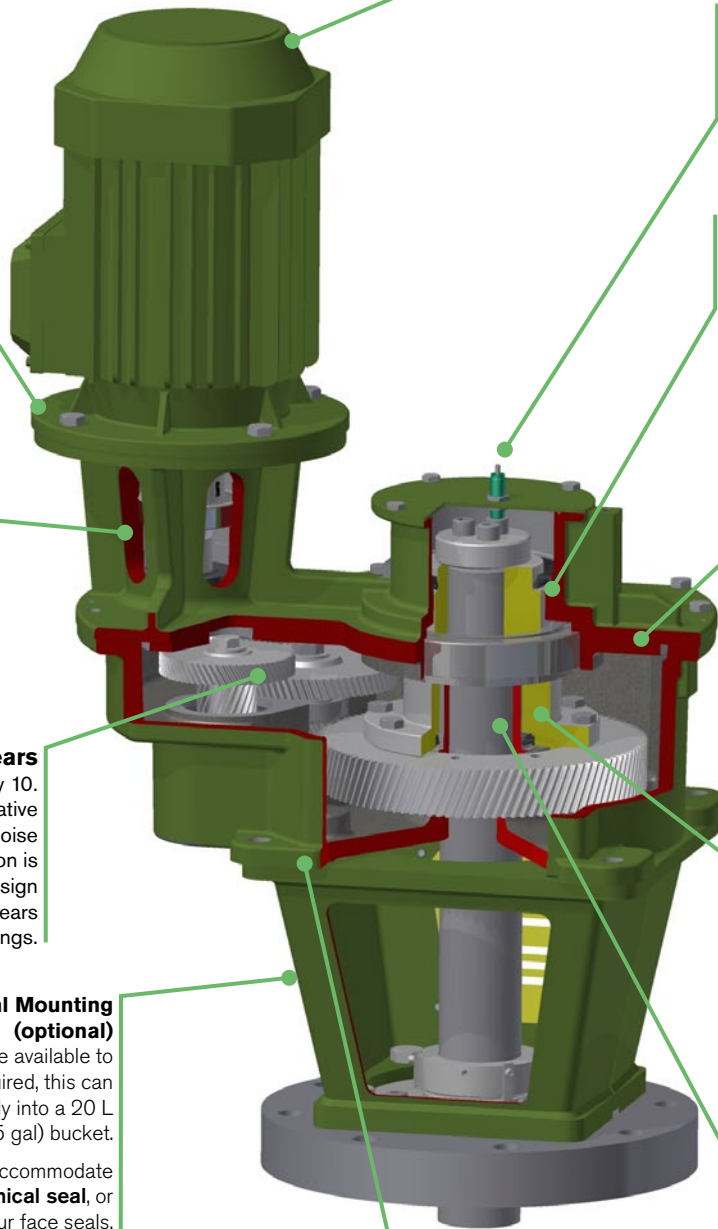

360 View of the Compact Series Mixer



Manufacturing

We continue to develop our global manufacturing footprint by adding capacity to our Xidu operation in Shanghai, China. Projects undertaken so far building upon our Series 10 ability, have included 70 Series localization, in house shaft and impeller welding operations and impeller blade forming.

With the Compact Series project, we have invested in the machine tools to produce shafts in our facility in China. The key production tooling we have added in our facility are:

- Long bed lathe for shaft production
- Horizontal Machining Center
- CNC Turning Center
- Shaft Straightening Press
- Key Cutter and Wheel Mill

By adding this capability to our extensive exiting SPX FLOW operation, we produce Compact and our other Lightning Series 10 and 70 Series mixer products in every region, which enables us to meet market delivery expectations with a high quality product.

The new machines and the dedication of factory space to our Mixer products is a significant investment in our manufacturing capability globally. Our capable supply chain and logistic team already transact business on supporting our global operations, making this a benefit for all our customers.



Quality Control

Investing in quality is investing in our future. Our investment in machine tools allows SPX FLOW to control all of the elements of production to ensure we can deliver our high quality product on time to our customers.

Recent investments include in house certified welding operations, blade pressing tools and gearbox assembly tooling. Additionally, in preparation for shaft manufacture, we have invested in our own shaft checking and straightening tools.

All of our SPX FLOW mixer facilities are ISO9001:2015 certified ensuring consistent design and manufacturing methodologies all over the world for our products.



SPX FLOW, Inc. reserves the right to incorporate our latest design and material changes without notice or obligation. Design features, materials of construction and dimensional data, as described in this bulletin, are provided for your information only and should not be relied upon unless confirmed in writing. Please contact your local sales representative for product availability in your region. The green "➤" is a trademark of SPX FLOW, Inc.

For more information, visit www.spxflow.com/lightnin.