

APV CU4*plus* 24V IO-Link Control Unit



SAFETY AGAINST EXPLOSION - FOR IECEx ZONE 2 GAS APPLICATIONS

FORM NO.: H348017 REVISION: GB-1

READ AND UNDERSTAND THIS MANUAL PRIOR TO OPERATING OR SERVICING THIS PRODUCT.





CE Declaration of Conformity
UKCA Declaration of Conformity

We,

DESIGN CENTER/MANUFACTURER: SPX Flow Technology Germany GmbH
Gottlieb-Daimler-Str. 13, D-59439 Holzwickede

MANUFACTURING FACILITY: SPX Flow Technology Poland sp. z o.o.
Rolbieskiego 2, 85-862 Bydgoszcz, Poland

AUTHORIZED REPRESENTATIVE: SPX Flow Europe Ltd.
(for UKCA) Part Ground floor, Alexander House
4 Station Road Cheadle Hulme
UK SK8 5AE United Kingdom

declare under our sole responsibility that the

CU4 Direct Connect, AS-interface Control Units for IECEx ATEX Zone 2
CU4plus Direct Connect, AS-interface, IO-Link Control Units for IECEx ATEX Zone 2
Explosion subcategory / Equipment marking:
II 3 G Ex ec IIB T4 Gc
IECEX TUN 22.0020X
TÜV 23 ATEX 349764 X
0°C ≤ Tamb. ≤ +55°C

meet the requirements of the
IECEX ATEX Standards

IEC 60079-0:2017, Edition 7.0 and IEC 60079-7:2017, Edition 5.1 as well as
EN IEC 60079-0:2018 and EN IEC 60079-7:2015/ A1:2018
TÜV NORD CERT GmbH, Hanover-Office, Am TÜV 1, 30519 Hanover, Germany,
Notified Body number: 0032

Electromagnetic Compatibility Directive 2014/30/EU
& protection class IP 64 EN 60529, EN 61000-6-2, EN 61000-6-4, EN 60068-2-6
RoHS Directive 2011/65/EU

Holzwickede, Nov. 2023

Dr.-Ing. Behdad Ariatabar, Design Center Lead - Valves

meet the requirements of the
Equipment and Protective Systems Intended for Use in Potentially Explosive Atmospheres
Regulations 2016 No. 1107 & BS harmonized standards
Electromagnetic Compatibility Regulations 2016 No. 1091 & BS harmonized standards
Restriction of Use of Certain Hazardous Substances in Electrical and Electronic Equipment
Regulation 2012 No. 3032

DocuSigned by:

Manchester, Nov. 2023

Mark Shanahan, VP Finance N&H Solutions

SPX FLOW

SPX_FLOW_CU4.plus.24V IO-Link_IECEX_Zone 2_GB-1_012024_for D4_Valves.indd

	Content	Page
0.	IECEX Specific Instructions	6
0.1.	General Information	
0.2.	IECEX Specific Symbol	
0.3.	Authorized Use	
0.4.	Specific Safety Instructions	
0.5.	Identification of CU4** resp. CU4*plus* Control Units for use in IECEX ATEX environment	
0.6.	Responsibilities	
1.	Abbreviations and Definitions	10
2.	Safety Instructions	10
2.1.	Sentinels	
2.2.	Intended use	
2.3.	General regulations for careful handling	
2.4.	Welding instructions	
2.5.	Persons	
2.6.	Warranty	
3.	General Terms	13
3.1.	Purpose of use	
3.2.	Design of CU4plus IO-Link	
3.3.	Function of the individual components	
4.	Mechanics and Pneumatics	16
4.1.	Air connections seat valves and double seat mix proof valves	
4.2.	Pressure relief valve	
4.3.	Functional description - block diagrams	
4.4.	Technical data / Standards	
4.5.	Solenoid valves	
4.6.	Throttling function	
5.	Adapter	21
6.	Electronic Module	22
6.1.	Function/block diagram	
6.2.	Functional description of connection	
6.3.	Technical data	
6.4.	Connections	
6.5.	Configuration	
6.6.	LED indication / Indicator lights	
6.7.	Wiring	
6.8.	Adjustment of valve profiles	
6.9.	Data signals	
6.10.	Data Storage Mode / Firmware Update	
6.11.	Seat Pulsation - Efficiency in Cleaning	
6.12.	Service and Maintenance Software CU4plus Toolbox	
6.13.	Data Acquisition and BLOB Data Transfer	
6.14.	Valve Monitoring	
7.	Valve Position Indication	53
7.1.	Continuously measuring valve position measuring system	
7.2.	Tolerance band of the valve position measuring system	
7.3.	Adjustment of valve position indication / Teach-in	
7.4.	Teach closed position	
7.5.	To be observed before Teach-in:	
7.6.	Use of external sensors	
8.	CU Assembly and Startup	57
8.1.	Double seat mix proof valves D4, D4 SL	
9.	Accessories and Tools	60
10.	Service	61
10.1.	Dismantling	
11.	Trouble Shooting	62
12.	IECEX / CCC Certificate of Conformity	63
13.	Spare Parts Lists	63

0. IECEx Specific Instructions

0.1. General Information

These **IECEx** Specific Safety Instructions apply for **CU4** resp. CU4*plus* Control Units** used in Potentially Explosive Atmospheres **Zone 2, Gas** applications. The equipment was assessed according to IEC 60079-0:2017, Edition 7.0 and IEC 60079-7:2017, Edition 5.1.

Notified body: TÜV NORD CERT GmbH, Hanover-Office
Am TÜV 1, 30519 Hanover, Germany
Notified Body number: 0044

These instructions shall be read carefully by the competent operating and maintenance personnel.

We point out that we will not accept any liability for damage or malfunctions resulting from the non-compliance with these instructions.

0.2. IECEx Specific Symbol



DANGER! WARNING! CAUTION!

This symbol draws your attention to important directions which have to be observed for the operation in explosive areas.

Failure to observe the warning may result in fatal or serious injury as well as damage to property!

0.3. Authorized Use

The Control unit type CU4** resp. CU4*plus* is designed to be mounted to pneumatic actuators of process valves for the control of media as used in the food and beverage industries as well as in pharmaceutical and chemical applications.

The control unit is installed on a pneumatic actuator of a process valve. The process valve and the actuator must have at least the IECEx ATEX approval of the control unit.

SPX FLOW will be held responsible only for the control units supplied and selected according to the operating conditions indicated by the customer or end user and as stated in the order confirmation. If in doubt, contact your local supplier.

Observe the admissible data, operating conditions and conditions of use as specified in the contract documents, instruction manuals and on the type label.

The control unit must only be used with SPX FLOW valves and components recommended and authorized by SPX FLOW.

Adequate transport, storage and installation, careful handling and maintenance are essential for a faultless and reliable function of the control unit.

Observe the intended use of the control unit.

0. IECEX Specific Instructions



0.4. Specific Safety Instructions

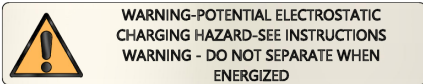

lead seal

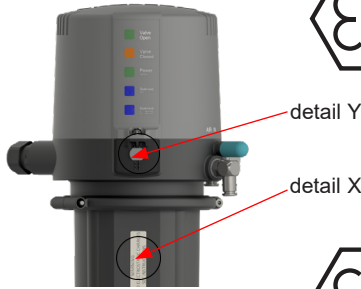

Connecting/Disconnecting pluggable electric circuits

- The connecting and disconnecting of the pluggable electrical circuits including field wirings is only permitted in the absence of explosive atmosphere.

Opening the device

- Do not open the control unit in the presence of explosive atmosphere.
- Do not install and set the proximity switches in the presence of explosive atmosphere.
- Before startup, secure the cover with the enclosed lead seal. Opening the cover without tools must be prevented.

Electrostatic discharge

- The control unit has to be installed and used in such a way, that electrostatic charging from operation, maintenance and cleaning is excluded.
- Connect the earthing screw in order to integrate the control unit in the local potential equalization system.
- In case of sudden discharge from electrostatically charged devices or individuals, risk of explosion in the explosive area exists.
- Prevent the occurrence of electrostatic discharges by suitable measures.
- Clean the control unit surface by gently wiping it with a damp or antistatic cloth, only.



earthing screw connection

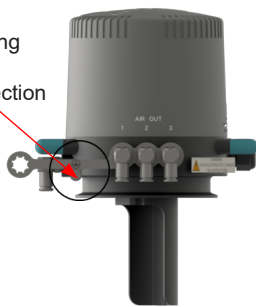

In order to prevent the emergence of explosion risks observe the safety instructions of the instruction manual and adhere to the following:

- Observe information on temperature classes, ambient temperatures, degree of protection and voltage on the approval ID label.
- Do not use control units in areas subject to gas with lower ignition temperatures than indicated on the approval ID label.
- Installation, operation and maintenance may only be performed by qualified personnel.
- Observe the applicable international and national safety regulations as well as the general rules of technology for construction and operation.
- Do not repair the control unit yourself. Replace it by an equivalent device.
- Repairs may only be performed by the manufacturer.
- Do not expose the control unit to mechanical and/or thermal loads which may exceed the limits described in the instruction manual.
- Only use cable and/or line entry points approved for the respective application area and which are screwed in place according to the respective installation instructions.
- The cable glands may be used for fixed installations, only.
- Close all unnecessary cable glands with locking screws approved for the explosive area.



detail X: electrostatic risk label
CU4 D4 IECEX Z2

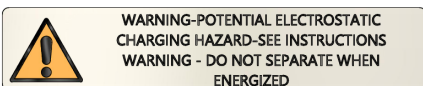

detail Y: type label
control unit

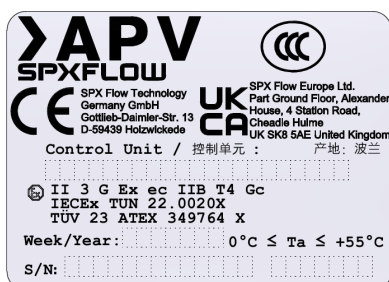

0. IECEx Specific Instructions

0.4. Specific Safety Instructions



In order to prevent the emergence of explosion risks observe the safety instructions of the instruction manual and adhere to the following:

- The required degree of protection (IP64) is guaranteed only in connection with suitable adaption sets. All pneumatic and electrical connections must be equipped with suitable connectors.
- Install the control unit in such a way that it is protected from UV-radiation.
- The control unit has to be installed in such a way that a pollution degree 2 or better, according to IEC 60664-1, is achieved.
- Externally to the control unit, measures have to be taken to provide a transient protection which ensures that the rated voltage, connected to the power supply terminals, is not exceeded by more than 40 %.
- Ambient temperature range: $0\text{ }^{\circ}\text{C} \leq T_{amb} \leq +55\text{ }^{\circ}\text{C}$



- 安全使用条件:
- 使用环境温度: $0\text{ }^{\circ}\text{C} \sim +55\text{ }^{\circ}\text{C}$
- 控制单元CU4**和CU4*plus*在安装和使用时, 避免在操作, 维护和清洁时产生静电
- 控制单元CU4**和CU4*plus*在安装时必须防止紫外线照射
- 在爆炸性危险场所严禁连接和断开电路
- 根据GB/T 16935.1, 该设备只应在污染程度不低于2级的区域使用
- 控制单元CU4**和CU4*plus*的瞬态保护应提供不超过设备的供电端子额定峰值电压值140%的保护

0. IECEX Specific Instructions

0.5. Identification of CU4** resp. CU4*plus* Control Units for use in IECEX ATEX environment



IECEX / ATEX - identification:

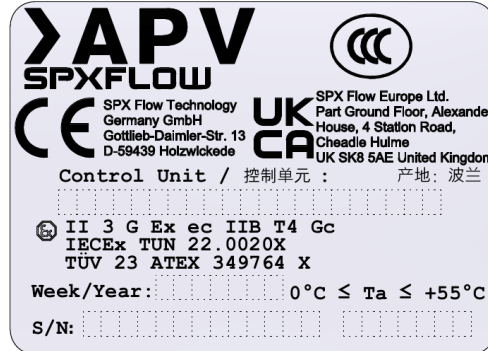

Equipment group II

Explosion subcategory
Ex ec IIB T4 Gc

Ambient temperature
 $0\text{ }^{\circ}\text{C} \leq T_{\text{amb}} \leq +55\text{ }^{\circ}\text{C}$



0.6. Responsibilities

It is within the operator's responsibility to ensure that the specified product temperatures are not exceeded and that regular inspections and maintenance are carried out to provide for proper function of the control unit and valve.

The following pages show the operating instructions for the standard control unit for non - IECEX ATEX applications.

1. Abbreviations and Definitions

A	Exhaust Air
AWG	American Wire Gauge
CE	Communauté Européenne
CU	Control Unit
DI	Digital Input
DO	Digital Output
EMC	Electromagnetic Compatibility
EU	European Union
GND	Ground/mass potential
IP	International Protection
LED	Light Emitting Diode
N	Pneumatic Air Connection NOT element
NEMA	National Electrical Manufacturers Association
P	Supply Air Connection
PELV	Protected Extra-Low Voltage
PWM	Pulse-width modulation
Y	Pneumatic Air Connection
SDCI	Digital Communication Interface Technology for Small Sensors and Actuators
SLD	Seat Lift Detection / Seat Lift Gathering

2. Safety Instructions

2.1. Sentinels

Meaning:



Danger!

Direct danger which can lead to severe bodily harm or to death!



Caution!

Dangerous situation which can lead to bodily harm and/or material damage.



Attention!

Risk as a result of electric current.



Note!

Important technical information or recommendation.

These special safety instructions point directly to the respective handling instructions. They are accentuated by the corresponding symbol. Carefully read the instructions to which the sentinels refer. Continue handling the control unit only after having read these instructions.

2. Safety Instructions

2.2. Intended use

The CU4plus IO-Link control unit is only intended for use as described in chapter 3.1. Use beyond that described in chapter 3.1. do not comply with the regulations and SPX FLOW shall not be responsible for any damage resulting from this non-observance. The operator bears the full risk. Prerequisites for proper and safe operation of the control unit are the appropriate transport and storing as well as the professional assembly. Intended use also means the observance of operating, service and maintenance conditions.

2.3. General regulations for careful handling

To ensure a faultless function of the unit and a long service life, the information given in this instruction manual as well as the operating conditions and permissible data specified in the data sheets of the control unit for process valves should be strictly adhered to.

- The operator is committed to operating the control unit in faultless condition, only.
- Observe the general technical rules while using and operating the unit.
- Observe the relevant accident prevention regulations, the national rules of the user country as well as your company-internal operating and safety regulations during operation and maintenance of the unit.
- Switch off the electrical power supply before carrying out any work on the system!
- Note that piping or valves that are under pressure must not be removed from a system!
- Take suitable measures to prevent unintentional operation or impermissible impairment.
- Following an interruption of the electrical or pneumatic supply, ensure a defined and controlled re-start of the process!
- If these instructions are not observed, we will not accept any liability. Warranties on units, devices and accessories will expire!

2. Safety Instructions



2.4. Welding instructions

It is generally recommended to avoid welding work in process installation in which control units are installed and connected. If welding is nonetheless required, earthing of the electrical devices in the welding area is a necessity.



2.5. Persons

- Installation and maintenance work may only be carried out by qualified personnel and by means of appropriate tools.
- Qualified personnel must get a special training with regard to possible risks and must know and observe the safety instructions indicated in the instruction manual.
- Work at the electrical installation may only be carried out by personnel specialized in electrics!

2.6. Warranty

This document does not contain any warranty acceptance. We refer to our general terms of sale and delivery. Prerequisite for a guarantee is the correct use of the unit in compliance with the specified conditions of application.



Note!

This warranty only applies to the Control Unit. No liability will be accepted for consequential damage of any kind arising from failure or malfunction of the device.

3. General Terms

fig. 3.2.

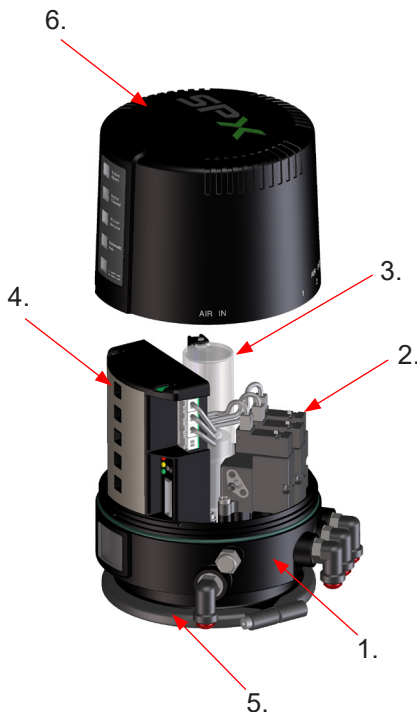

3.1. Purpose of use

The control unit CU4plus IO-Link has been developed for the control of process valves in food processing industry as well as related industries.

The CU4plus IO-Link control unit operates as interface between process control and process valve and controls the electric and pneumatic signals.

The pneumatic control of valves is undertaken via the solenoid valves. The control unit controls the valve positions, **open** and **closed**, via sensors. The electronic module undertakes the task to process the switching signal from the control and to control the corresponding solenoid valves. The electronic module also provides for potential-free contacts. The corresponding light signals in the control unit provide for an external indication of the valve positions.

3.2. Design of CU4plus IO-Link (fig. 3.2.)

The CU4plus IO-Link control unit consist of the following components:

1. The Control Unit base with integrated air channels and electric and pneumatic connections as well as window with type label.
2. 1 or 3 solenoid valves for the control of the valve actuators and for the seat lifting of double seat valves.
 - 1 solenoid valve with 1 logic NOT element for the control of the valve actuators.
3. Sensor module with integrated position measuring system for the detection of the valve position.
4. Electronic module for the electric supply, for the IO-Link communication with the PLC, evaluation of feedback signals, pressure sensor and control of solenoid valves as well as valve position indication through LED.
5. Clamp ring to fasten the CU4plus on the adapter.
6. Cover with optical window.
7. Pressure sensor to control the air pressure of the main actuator.

fig. 3.2.1

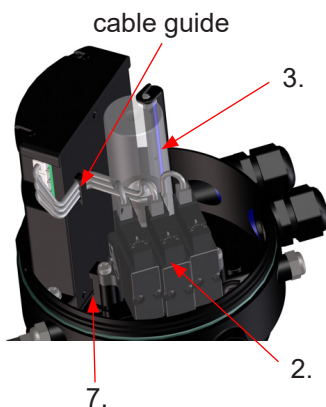

The cable/s by means of which the solenoid valves are connected with the electronic module must be guided through the cable guide at the rear side of the electronic module. (fig. 3.2.1).

3. General Terms

3.3. Function of the individual components

The installation of the control unit is undertaken by special adapters which are available for the different valves types, see **chapter 5. Adapter**. The snap connectors for supply air and pneumatic air to the individual cylinders at the valves are located at the outside of the control unit. At the control units for valves with turning actuator, the pneumatic air is transferred internally to the actuator. The air supply of the control unit is equipped with an exchangeable air filter. Observance of the required compressed air quality is imperative. Please also see **chapter 4.5 Technical Data**.

The number of the solenoid valves installed in the CU4plus depends on the valve actuators to be controlled. Single seat and butterfly valves and double seat valves without seat lift function require 1 solenoid valve.

Control units for double seat valves equipped with 3 solenoid valves. For the manual actuation, the solenoid valves are provided with a safe handle which is easy to operate.

The electronic module installed in the control unit fulfills the task to process the electric signals from the control, to activate the solenoid valves and to evaluate the feedback signals from the feedback unit. Moreover, the signalling and indication of the valve positions as well as additional diagnostic functions are undertaken via the electronic module.

The electronic module is the interface between actuators, sensors and the superior control system. The CU4 IO-Link module described herein provides for the installation connected to an IO-Link Master.

Valve position detection is realized via linear sensors which are integrated in the sensor module.

The switching cam mounted on the actuator rod triggers the signals on the linear sensor. The measuring range of the linear sensor detects the complete valve stroke. By means of the Teach-in function, the corresponding position for closed and open valve position are detected and seat lift positions are permanently saved in the electronic module if required. (see **chapter 7.3 Teach-in function**)

For DA3+ double seat valves with active seat lift detection (SLD) additionally to the linear sensor integrated in the CU, two external proximity switches installed at the valve actuator are required.

The corresponding signals of the linear sensor as well as external proximity switches are evaluated in an internal logic circuit and, thus, the corresponding valve position indications are generated. (see **chapter 6.7. Data signals, PLC communication**)

For the D4 valve generation, additionally to the linear sensor integrated in the control unit, an additional sensor is installed in the lower part of the sensor tower.

3. General Terms

3.3. Function of the individual components

The luminous diodes are located on the front side of the electronic module. Their signals are visibly indicated to the outside by an optical window in the cover the control unit. Beside the open and closed valve position, the existence of the operating voltage as well as different diagnostic information are indicated. **Chapter 6.6.** LED indicators provides more details.

The complete control unit has been designed on the building block principle. By exchange of the electronic module, the control type can be changed, e.g. from direct control (Direct Connect) to communication with AS-Interface or IO-Link.



Note! Wiring must be changed!

4. Mechanics and Pneumatics

4.1. Air connections seat valves and double seat mix proof valves

4.1.1. Function

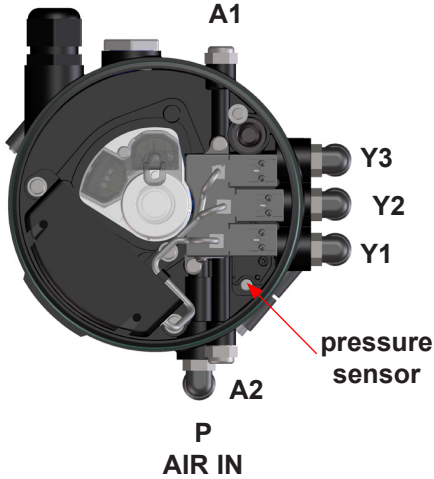

CU41plus-D4-IO-Link

design for D4 double seat mix proof valves without seat lift function

- P** air supply with integrated particle filter
- Y1** control air connection for main actuator **pressure sensor** to measure the air pressure of the main actuator
- A1** exhaust air, with exhaust silencer

CU43plus-D4-IO-Link

design for D4 SL double seat mix proof valves with seat lift function

- P** air supply with integrated particle filter
- Y1** control air connection for main actuator **pressure sensor** to measure the air pressure of the main actuator
- Y2** pneumatic air connection for seat lift actuator of upper seat lifting
- Y3** pneumatic air connection for seat lift actuator of lower seat lifting
- A1/A2** exhaust air, with exhaust silencer

4.2. Pressure relief valve

The base of the control unit is equipped with a pressure relief valve which prevents an inadmissible pressure build-up in the inner control unit.

If required, the pressure relief valve vents into the clearance between the base and the adapter of the control unit.

The pressure relief valve must not be mechanically blocked under any circumstances.



4. Mechanics and Pneumatics

4.3. Functional description - block diagrams

4.3.1. CU41plus-D4 IO-Link for D4 double seat mix proof valves

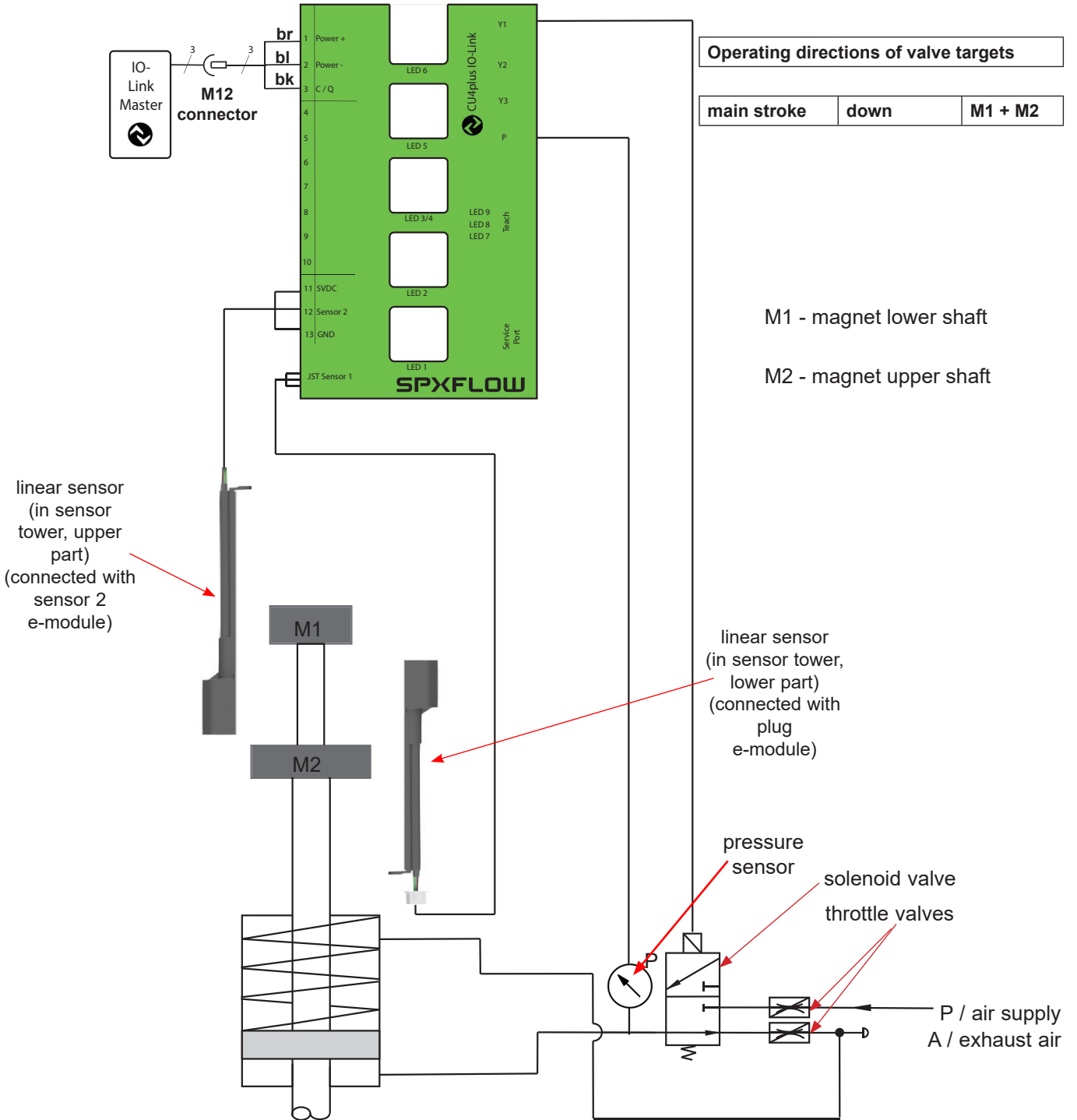

4. Mechanics and Pneumatics

4.3. Functional description - block diagrams

4.3.2. CU43plus-D4 IO-Link for D4 SL double seat mix proof valves

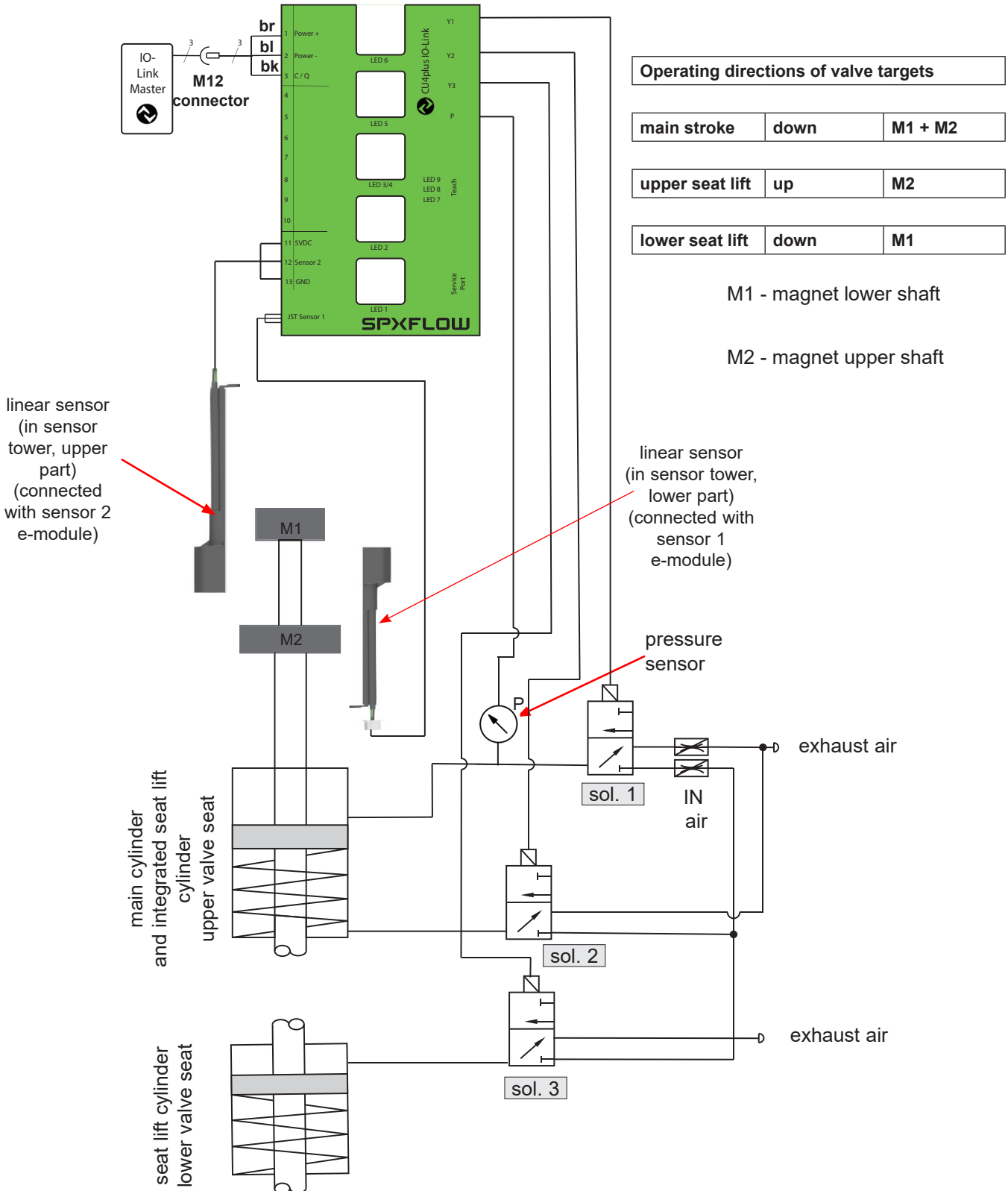

4. Mechanics and Pneumatics

4.4. Technical data / Standards

Material: PA6.6/PA12

Ambient temperature: -20 to +70 °C, -4 to +158 °F

EU: EMC 2014/30/EU (89/336/EEC)

Standards and environmental audits:

protective class IP 64 EN 60529
EMC

DIN EN 55011

DIN EN 6100-4-2,3,4,5,6

vibration/oscillation EN60068-2-6

safety of machinery DIN EN ISO
13849-1,2

Tolerance band: +/- 1 mm, +/- 2 mm, +/- 5 mm
depending on the valve type

Air hose: 6 mm / ¼" OD

Pressure range: 6–8 bar

Compressed air quality: quality class acc. to DIN ISO 8573-1

- **content of solid particles:** quality class 3,
max. size of solid particles per m³
10000 of 0,5 µm < d < 1,0 µm
500 of 1,0 µm < d < 5,0 µm
- **content of water:** quality class 3,
max. dew point temperature -20 °C
For installations at lower temperatures
or at higher altitudes, additional
measures must be considered to reduce
the pressure dew point accordingly.
- **content of oil:** quality class 1,
max. 0,01 mg/m³

The oil applied must be compatible with Polyurethane elastomer materials.

4. Mechanics and Pneumatics

**solenoid valve
block 1**

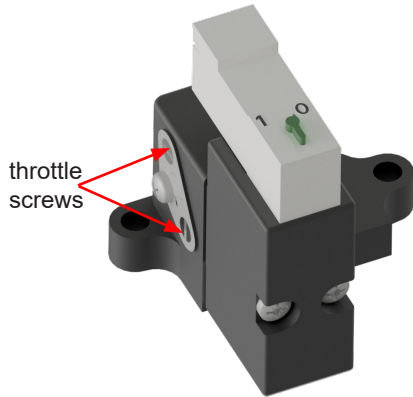

4.5. Solenoid valves

In the base of the control unit max. 3 solenoid valves are installed. The 3/2-way solenoid valves are connected with the electronic module by moulded cables and plug connector.

control: PWM signal
handle: rotary switch at valve

4.6. Throttling function

The operating speed of the valve actuator can be varied or reduced. This may be necessary to slacken the actuation of the valve in order to prevent pressure hammers in the piping installation. For this purpose, the supply and exhaust air of the **first solenoid valve** can be adjusted via the throttling screws respectively allocated in the interface of the solenoid valve. By turning the screws in anticlockwise direction, the inlet or outlet air is throttled.

**solenoid valve
block 3**

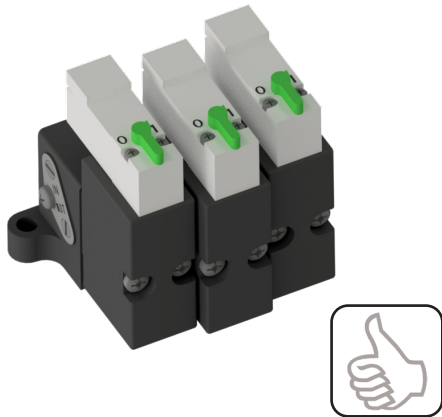

5. Adapter

Double seat mix proof valves D4, D4 SL



6. Electronic Module

6.1. Function/block diagram

The electronic module CU4plus IO-Link operates as interface between superordinated control (PLC) and is connected to the PLC via an IO-Link master. The connection is accomplished by a 3-wire cable with a M12 plug. The input voltage and the signal is transferred by this cable. Both in accordance with the IO-Link specification. The electronic module operates in the ranges such as the control of the solenoid valves, position feedback and LED indication. Control of the solenoid valves is effected in energy-saving manner via pwm-signals.

For mix proof valves of the D4 family the electronic module works with 2 SPX linear sensor systems.

For single seat valves and butterfly valves the electronic module only works with 1 SPX linear sensor system.

For special valves or previous valve generations the electronic module can also work with 2 SPX proximity switches or in combination of proximity switches and linear sensor.

Make sure that only SPX feedback sensors are used with the CU4plus IO-Link electronic module.

Please refer to chapter 6. Electronic module / Technical Data.

6. Electronic Module

6.1. Function/block diagram

6.1.1. CU41plus-D4 IO-Link CU43plus-D4 IO-Link

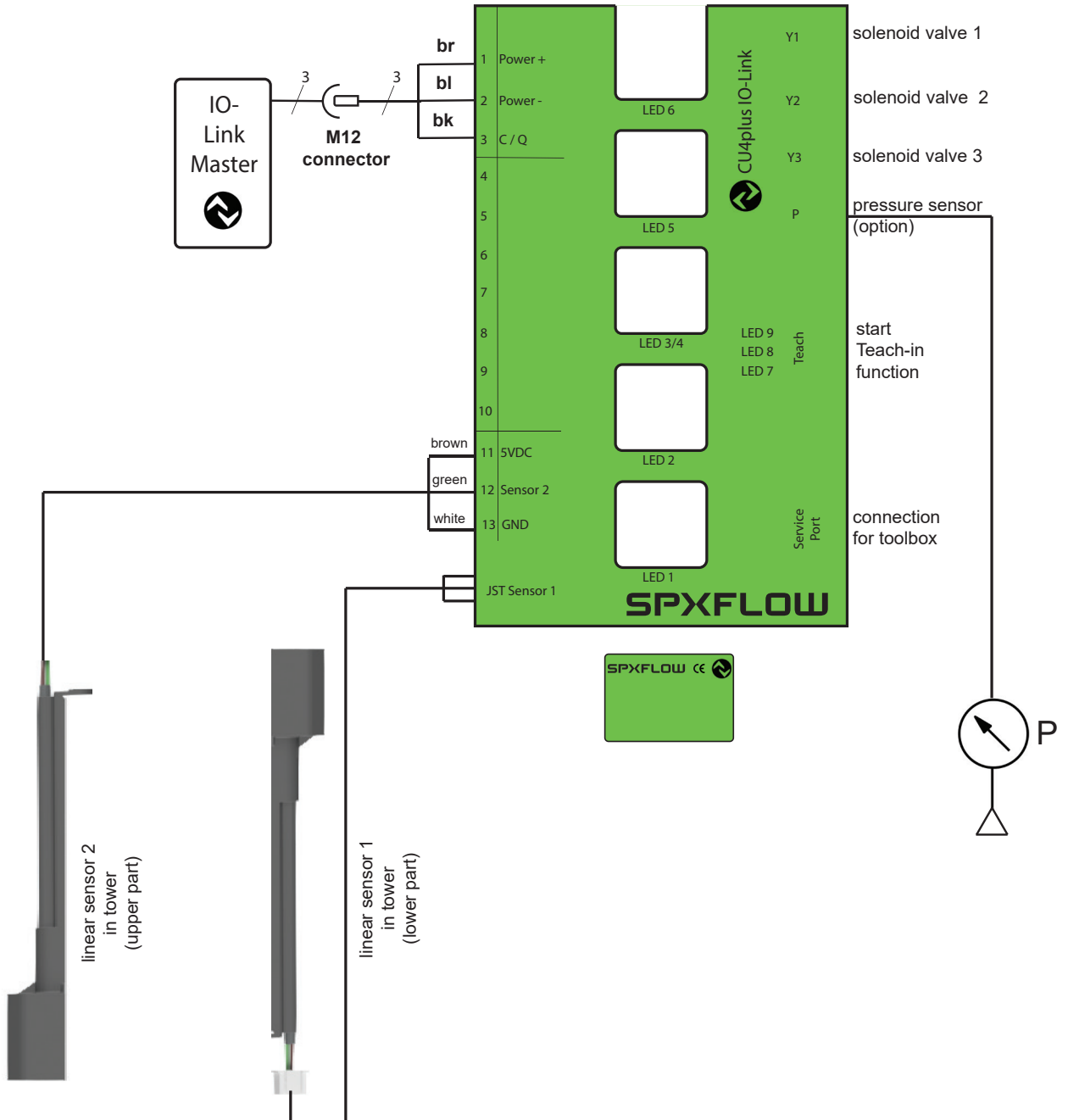

6. Electronic Module

6.2. Functional description of connection

Terminal	Designation	Functional Description
1	Power+	Operating voltage +
2	Power-	Operating voltage - or Ground
3	C / Q	IO-Link Signal
4 ... 10		Not in use
11	5 VDC	Voltage supply for valve sensor or extension module
12	Sensor 2	Sensor 2 connection or extension module
13	GND	Mass potential for sensor supply or extension module
JST	Sensor 1	Linear Sensor 1
14	Sensor 2	Sensor Signal 2
15	GND	Mass potential for sensor supply
Y1	PWM Output	Solenoid valve 1 (main valve)
Y2	PWM Output	Solenoid valve 2 (upper seat lift)
Y3	PWM Output	Solenoid valve 3 (lower seat lift)
service port		Connection serial/USB converter for CU4plus toolbox
P	Pressure sensor	Pressure measurement of main actuator

6. Electronic Module

6.3. Technical data

Operating voltage:	18 – 30V DC
Ripple:	max. 1,3Vpp (peak to peak)
Inrush charge:	lower 20mAs
Supply of solenoid valve:	pwm-signal from electronic module
Communication:	COM3 SDCI communication mode with transmission state of 230,4 kbit/s
IO-Link class:	Port class A
IO-Link revision:	1.1
Connection:	The default wiring complies with IEC 60947-5-2 and uses only three wires for 24V, 0V and a signal line.
SIO Mode:	not supported
Data storage mode:	fully supported
Connector:	M12 connector with 4 pins.
Voltage supply of sensors:	5VDC (+/-5%)
Power consumption	
Minimum	about 65mA @ 24VDC (Power ON, 2 LED, no solenoid valve, 2 Sensors)
Typically	about 86mA @ 24VDC (Power ON, 3 LED, 1 solenoid valve, 2 Sensors)
Maximum	about 105 mA @ 24VDC (Power ON, 3 LED, 2 solenoid valves, 2 Sensors)
Cable Length	max. 20 m (IO-Link specific)
Connecting terminals:	conductor cross section 0.5 – 1.5 mm ² (with conductor sleeve) complying with AWG 20-16
Firmware update:	by encrypted *.iolfw file

6. Electronic Module

6.4. Connections

Sensors for valve position detection:

Internal sensors: D4 Valves Linear Sensor 1: H339463

Linear Sensor 2: H339463

Sensor calibration: One button automatic calibration process for II valve types

Separate option for manual calibration of valve closed position

IO-Link approvals: IEC 611 31-9
Physical layer test
Device Conformance test

Control instruments: IEC 60947-5-2





















6.5. Configuration

IODD-File: Can be download from:
<https://ioddfinder.io-link.com/>

Vendor IO: 13763

Device ID: 1

6. Electronic Module

6.6. LED indication / Indicator lights			
External luminous displays			
Valve Open	color green, permanent light		valve in open position
	color green, flashing		no valid Teach data
Valve Closed	color orange, permanent light		valve in closed position
	color orange, flashing		no valid Teach data
Power Diagnose	color green, permanent light		operating voltage at module - faultless
	color green, flashing		solenoid lever activated
	color green, red alternating		solenoid failure (wire break, short circuit)
	color green, red alternating		linear sensor failure
	color green, red alternating		air pressure out of range
	color red, flashing		Teach parameters not ok
Solenoid Main	color blue, permanent light		main solenoid valve (1) controlled
Solenoid o upper seat oo lower seat	color blue, 1 blink		solenoid valve (2) for upper seat lift controlled
	color blue, 2 blinks		solenoid valve (3) for lower seat lift controlled
Software update	LED upper seat, LED lower seat alternating		bootloader active
LED 7	color green		Air pressure ok
	color green, flashing		Air pressure high
	color green, flashing		Air pressure low
LED 8			Service request
LED 9	color red		Teach procedure active
	color red, flashing		no valid teach data
Internal luminous displays			
Luminous diode	1		1st solenoid valve (1) controlled
Luminous diode	2		2nd solenoid valve (2) controlled
Luminous diode	3		3rd solenoid valve (3) controlled

6. Electronic Module

6.6. LED indication / Indicator lights

			Process Signal (from FW-V2.00)	
All LED's	Running light with all led's		LED signal blink	Indicate a CU4plus in the field
LED 7	color green		Air pressure ok	Air pressure ok
	color green, flashing		Air pressure fail	Air Pressure high
	color green, flashing		Air pressure fail	Air Pressure low
LED 8	Color yellow		Service request	Service request
LED 9	Color Red		Teach active	Teach procedure active
	Color red, flashing		Invalid teach data	No valid teach data

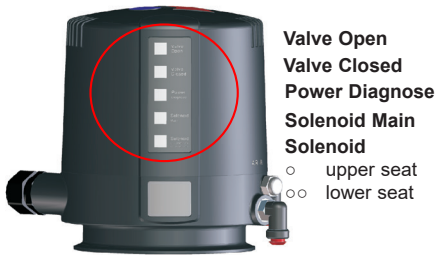

Function LEDs



Solenoid valve connections

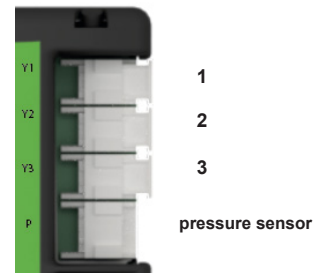

SPX FLOW

6. Electronic Module

6.7. Wiring			
PIN	Signal	Description	Core color (acc. to IEC 60947-5-2)
1	L+	24V power supply (Power +)	brown
2	I/Q	Not connected	white
3	L-	Power supply ground (Power -)	blue
4	C/Q	IO-Link communication SIO is not supported	black

Plug

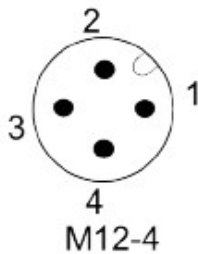

A cable with a core cross-sectional area of 0,35 mm² and a length of up to 20 m can be used to connect the IO-Link master and the CU4plus IO-Link. No special calculation is required in this case. Nevertheless, the supply cables between the power supply unit and the IO-Link master should be checked for voltage drops.

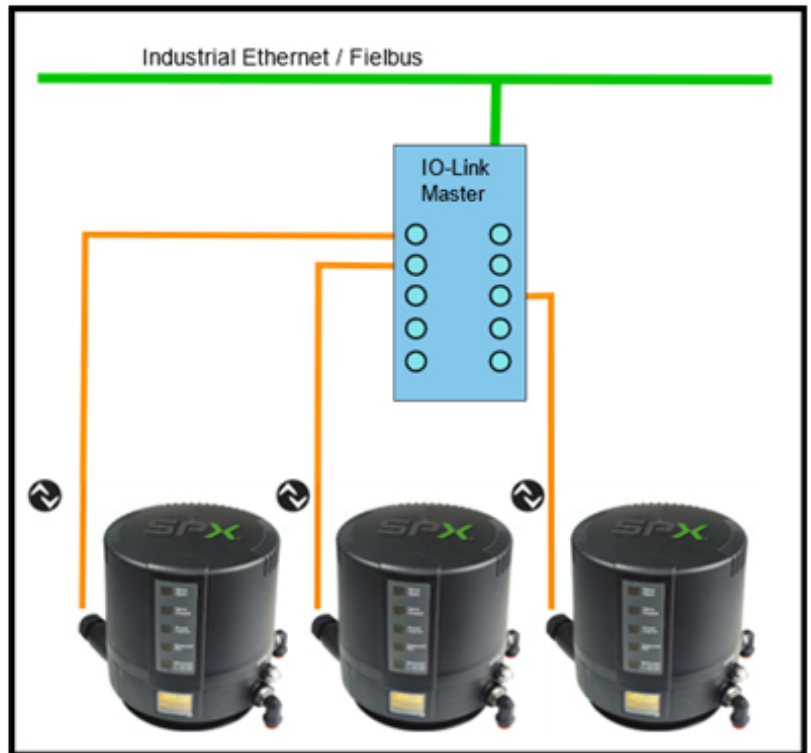

Example of system architecture with CU4 plus IO-Link

6. Electronic Module

6.8. Adjustment of valve profiles

The adjustment of valve parameters is carried out within the IO-Link Master or a special configuration master.

For the different process valves different logic profiles exist. These differ in view of the detection of the feedback and the logic profile of the valve. These parameters are bundled in the group "System Parameters".

Valve types:

Type	Valve profile	Valve position measuring system	Tolerance band	Valve basic position NO/NC	Invert - valve position indication	Number of solenoids
1	Mix proof valve D4	2 internal linear sensors	fixed +/- 1 mm	NC only	possible	always 1
2	Mix proof valve D4 SL	2 internal linear sensors	fixed +/- 1 mm	NC only	possible	always 3

Valve basic position: Depending on the valve type, the basic position can be adjusted.

Tolerance band: Selection according to valve type.
(see chapter 7.2)

Valve position indication: LED can be inverted, e.g. for adaption of valve type

Restore factory settings: Mix proof valve DA4 profile is adjusted.

Adjusted valve characteristics: logic profile 1, for DA3+ with SLD

Teach-in: CU waits for Teach-in with valve, LED 3-6 blink

Adjustment / change of valve profile is realized via the IO-Link Master in the parameter area.

6. Electronic Module

6.9. Data signals

6.9.1. Mix proof valve D4



operating	main stroke downwards		
main stroke	valve operating direction: downwards		
lower shaft	signal S3 signal S4	linear sensor 1	valve target M1
upper shaft	signal S2 signal S1	linear sensor 2	valve target M2

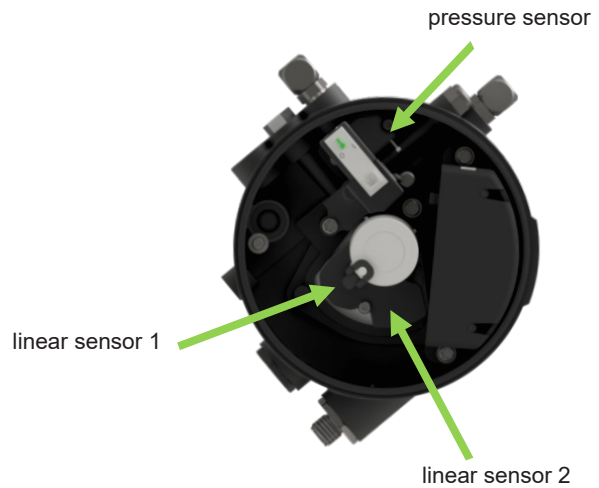

Output signals	valve status	linear sensor 2 / (Teach data)		linear sensor 1 / (Teach data)		tolerance band
		sensor signal S1	sensor signal S2	sensor signal S3	sensor signal S4	
O0	closed	1	0	not used	0	+1 mm, -1 mm
O1	open	0	0	not used	1	+1 mm, -1 mm
DI2						
DI3						

Input signal	solenoid 1 Main	solenoid 1 upper seat lift	solenoid 1 lower seat lift
I0	1	0	0
I1			
I2			

6. Electronic Module

6.9. Data signals

6.9.2. Mix proof valve D4 SL



operating	main stroke downwards upper seat lift upwards lower seat lift downwards		
main stroke	valve operating direction: downwards		
lower shaft	signal S3 signal S4	linear sensor 1	valve target M1
upper shaft	signal S2 signal S1	linear sensor 2	valve target M2

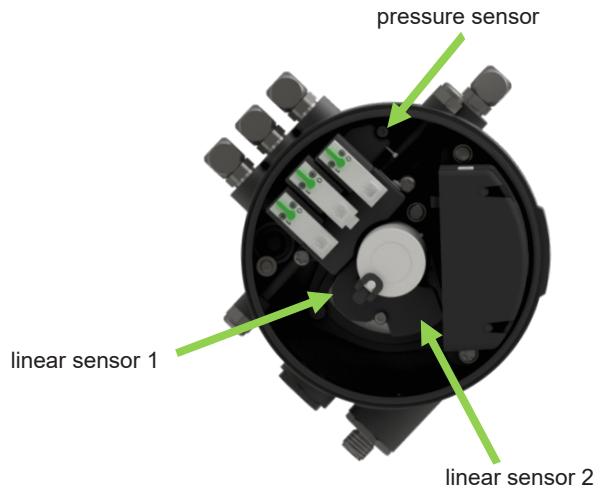

Output signals	valve status	linear sensor 2 / (Teach data)		linear sensor 1 / (Teach data)		tolerance band
		sensor signal S1	sensor signal S2	sensor signal S3	sensor signal S4	
O0	closed	1	0	1	0	+1 mm, -1 mm
O1	open	0	0	0	1	+1 mm, -1 mm
O2	upper seat lift	0	1	1	0	+1 mm, -1 mm
O3	lower seat lift	1	0	0	0	+1 mm, -1 mm

Input signal	solenoid 1 Main	solenoid 2 upper seat lift	solenoid 3 lower seat lift
I0	1	0	0
I1	0	1	0
I2	0	0	1

6. Electronic Module

6.9. Data signals

6.9.3. Process Data Input Signals

Name	Data Type	Unit	Bit Offset	Bit Length	Description
Valve Closed	Boolean		104	1	Signal for Valve in closed position
Valve Open	Boolean		105	1	Signal for Valve on Open position
Upper seat lift active	Boolean		106	1	Upper seat lift of a double seat valve active
Lower seat lift active	Boolean		107	1	Lower seat lift of a double seat valve active
Sensor Position 1	Boolean		98	1	Valve in calibrated linear sensor position 1. Needed for PMO valves.
Sensor Position 2	Boolean		99	1	Valve in calibrated linear sensor position 2. Needed for PMO valves.
Position Lift	Boolean		100	1	Valve in calibrated linear sensor position lift
Sensor Position 3	Boolean		101	1	Valve in calibrated linear sensor position 3. Needed for PMO valves.
Sensor Position 4	Boolean		102	1	Valve in calibrated linear sensor position 4. Needed for PMO valves.
External Sensor 3	Boolean		96	1	External proximity switch 3 active
External Sensor 4	Boolean		97	1	External proximity switch 4 active
Air Pressure	Unsigned integer	bar	64	32	Air pressure of the main actuator
Valve Shaft Position 1	Float		32	32	Linear sensor 1 position
Valve Shaft Position 2	Float		0	32	Linear sensor 2 position

6. Electronic Module

6.9.3.1 Process Data Output Signals Table for Firmware version beginning with FW-V2.0

Name	Data Type	Unit	Bit Offset	Bit Length	Description
Valve Closed	Boolean		120	1	Signal for valve in closed position
Valve Open	Boolean		121	1	Signal for valve in open position
Upper seat lift active	Boolean		122	1	Upper seat lift of a double seat valve active
Lower seat lift active	Boolean		123	1	Lower seat lift of a double seat valve active
Sensor Position1	Boolean		114	1	Valve in calibrated linear sensor position 1. Needed for PMO valves.
Sensor Position2	Boolean		115	1	Valve in calibrated linear sensor position 2. Needed for PMO valves.
Position Lift	Boolean		116	1	Valve in calibrated linear sensor position lift.
Sensor Position 3	Boolean		117	1	Valve in calibrated linear sensor position 3. Needed for PMO valves.
Sensor Position 4	Boolean		118	1	Valve in calibrated linear sensor position 4. Needed for PMO valves.
Sensor Position 5	Boolean		119	1	Valve in calibrated linear sensor position 5. Needed for PMO valves.
External Sensor 3	Boolean		112	1	External proximity switch 3 active
External Sensor 4	Boolean		113	1	External proximity switch 4 active
Air Pressure	Unsigned integer	bar	80	32	Air pressure of the main actuator
Valve Shaft Position 1	Unsigned integer		48	32	Linear sensor 1 position
Valve Shaft Position 2	Unsigned integer		16	32	Linear sensor 2 position
Teach Active	Boolean		0	32	Teach is running
Invalid Teach Data	Boolean		1	1	Invalid teach data
Service Request	Boolean		2	1	Service request present
Air Pressure ok	Boolean		4	1	Air pressure ok
Air Pressure fail	Boolean		5	1	Air Pressure error
Valve Monitor Error	Unsigned integer		8	8	Valve Monitor failure values: Bit 0 (0x01) EMV1 on error Bit 1 (0x02) EMV1 off error Bit 3 (0x04) EMV2 on error Bit 4 (0x08) EMV2 off error Bit 5 (0x10) EMV3 on error Bit 6 (0x20) EMV3 off error

6. Electronic Module

6.9.4. Process Data Output Signals

Name	Data Type	Unit	Bit Offset	Bit Length	Description
Main Valve	Boolean		0	1	Main Actuator
Upper Seatlift	Boolean		1	1	Actuator for the upper seatlift
Lower Seatlift	Boolean		2	1	Actuator for the lower seatlift
LED signal blink	Boolean		3	1	Special LED blinking sequence for to indicate this valve in the field.
Main valve pulsation	Boolean		4	1	Switching pulsation mode on. The valve must be activated with the signal 'Main actuator'.
Upper seat pulsation	Boolean		5	1	Switching the pulsation mode on for upper seat lift. The valve must be activated with the signal 'Upper Seatlift'.
Lower seat pulsation	Boolean		6	1	Switching the pulsation mode on for lower seat lift. The valve must be activated with the signal 'Lower Seatlift'.

6. Electronic Module

6.9. Data signals

6.9.5. Identification Parameter

Name	Index	Subindex	Type	Unit	Comment
Vendor Name	16	0	String		SPX Flow Technology Germany GmbH
Vendor Text	17	0	String		www.spxflow.com
Product Name	18	0	String		CU4plus IO-Link
Product ID	19	0	String		H344393
Product Text	20	0	String		Control Unit CU4plus IO-Link
Serial Number	21	0	String		
Hardware Version	22	0	String		
Firmware Version	23	0	String		
Application Specific Tag	24	0	String		Freely selectable
Function Tag	25	0	String		Freely selectable
Location Tag	26	0	String		Freely selectable
Hardware Identification Key	17342	0	String		Special for Firmware update

6.9.6. Operation Parameter

Name	Index	Subindex	Type	Unit	Comment
Operating hours	84	0	Unsigned Integer	h	Can be reset
Activation Timer	85	0	Unsigned Integer	ms	Can be reset
Reaction time activation	86	0	Unsigned Integer	ms	Can be reset
Deactivation time	87	0	Unsigned Integer	ms	Can be reset
Reaction time deactivation	88	0	Unsigned Integer	ms	Can be reset
Strokes Solenoid 1	89	0	Unsigned Integer		Can be reset
Strokes Solenoid 2	90	0	Unsigned Integer		Can be reset
Strokes Solenoid 3	91	0	Unsigned Integer		Can be reset

6.9.7. Lifetime Counter

Name	Index	Subindex	Rights	Type	Unit
Lifetime hours	95	0	RO	Unsigned Integer	h
Lifetime strokes Solenoid 1	96	0	RO	Unsigned Integer	St
Lifetime strokes Solenoid 2	97	0	RO	Unsigned Integer	St
Lifetime strokes Solenoid 3	98	0	RO	Unsigned Integer	St
Boot counter	108	0	RO	Unsigned Integer	St

6. Electronic Module

6.9. Data signals

6.9.8. Reset Button

Name	Index	Subindex	Value	Rights	Type	Unit
Reset Operating hours	93	0	1	WO	Button	
Reset Solenoid 1 counter	93	0	2	WO	Button	
Reset Solenoid 2 counter	93	0	3	WO	Button	
Reset Solenoid 3 counter	93	0	4	WO	Button	
Reset all Activation timer	93	0	5	WO	Button	

6.9.9. Parameter Menu

Name	Index	Subindex	Value	Rights	Type	Unit
Device Reset	2	0	128	WO	Button	
Application Reset	2	0	129	WO	Button	
Restore Factory Settings	2	0	130	WO	Button	

6.9.10. Service Parameter

Name	Index	Subindex	Rights	Type	Unit
Max. Hours	75	0	RW	Unsigned Integer	h
Max. Strokes	76	0	RW	Unsigned Integer	
Max. Activation time	77	0	RW	Unsigned Integer	ms
Max. Reaction time	78	0	RW	Unsigned Integer	ms
Max. Deactivation time	79	0	RW	Unsigned Integer	ms
Max. Reaction time deactivation	80	0	RW	Unsigned Integer	ms
Min. Pressure	81	0	RW	Unsigned Integer	bar
Max. Pressure	82	0	RW	Unsigned Integer	bar
Pressure delay	83	0	RW	Unsigned Integer	ms

6.9.11. System Parameter

Name	Index	Subindex	Rights	Type	Unit
Valve Type	66	0	RW	Unsigned Integer	
Solenoid Amount	65	0	RW	Unsigned Integer	
LED Display	67	0	RW	Unsigned Integer	
Pressure Sensor	68	0	RW	Unsigned Integer	
Tolerance	69	0	RW	Unsigned Integer	mm
Operating Principle	74	0	RW	Unsigned Integer	

6. Electronic Module

6.9. Data signals

6.9.11.1 Tolerances for D4-Valves (DA4, D4, D4SL, DT4, AM1)

Name	Index	Subindex	Rights	Type	Unit
Positive S1	126	0	RW	Unsigned Integer	mm
Negative S1	127	0	RW	Unsigned Integer	mm
Positive S2	128	0	RW	Unsigned Integer	mm
Negative S2	129	0	RW	Unsigned Integer	mm
Positive S3	130	0	RW	Unsigned Integer	mm
Negative S3	131	0	RW	Unsigned Integer	mm
Positive S4	132	0	RW	Unsigned Integer	mm
Negative S4	133	0	RW	Unsigned Integer	mm
Positive Lift	134	0	RW	Unsigned Integer	mm
Negative Lift	135	0	RW	Unsigned Integer	mm

6.9.11.2 AM1-Valve (Aseptic Mix Proof Valve) Parameters

Name	Index	Subindex	Rights	Type	Unit
Idle time for the upper seat lift signal	123	0	RW	Unsigned Integer	ms
Pressure level to suppress the upper seat lift signal	124	0	RW	Unsigned Integer	bar

6. Electronic Module

6.9. Data signal

6.9.12. Time based Pulsation

Name	Index	Subindex	Rights	Type	Unit
Pulse on upper SL	70	0		Unsigned Integer	s
Pulse off upper SL	71	0		Unsigned Integer	s
Pulse on lower SL	72	0		Unsigned Integer	s
Pulse off lower SL	73	0		Unsigned Integer	s

6.9.13. Teach

Name	Index	Subindex	Rights	Type	Unit
Teach Closed Position	94	0	WO	Button	
Complete automatic teach function	94	0	WO	Button	
Teach hour log	125	0	RO	Button	h

6.9.14. Diagnosis Menu, Error

Name	Index	Subindex	Rights	Type	Unit
Teach Error Code	92	0	RO	Unsigned Integer	

6.9.15. Data Acquisition Parameters

Name	Index	Subindex	Rights	Type	Unit	Range
Measurement interval	104	0	RW	Unsigned integer	s	1, 2, 5, 10
Delay for next trigger start	105	0	RW	Unsigned integer	hours days	1 hour 2 hours 6 hours 12 hours 1 day 7 days 14 days 21 days 30 days 90 days 180 days

6. Electronic Module

6.9. Data signals

6.9.16. Events

ID	Event Type	Event Code	IODD Text
CU4 Events			HEX
VALELOGIC_SENSOR1_POS_ERR1	ERROR	1801	ERROR1: Sensor Position
VALELOGIC_POSITION_QUERY	ERROR	1800	ERROR: Valve Logic position.
VALELOGIC_SENSOR1_POS_ERR2	ERROR	1802	ERROR2: Sensor Position
VALELOGIC_SOLENOID1	ERROR	1803	ERROR: Solenoid 1 (Main)
VALELOGIC_ERROR_EMV2	ERROR	1804	ERROR: Solenoid 2 (Upper Seat Lift)
VALELOGIC_ERROR_EMV3	ERROR	1805	ERROR: Solenoid 3 (Lower Seat Lift)
VALELOGIC_ERROR_MEMORY_SERVICE	ERROR	1806	ERROR: Service Memory
VALELOGIC_ERROR_MEMORY_SYSTEM	ERROR	1807	ERROR: System Memory
VALELOGIC_ERROR_VALVE_SETTIG	ERROR	1808	ERROR: Valve Settings
VALELOGIC_ERROR_TEACH_1	ERROR	1809	Logic ERROR: Teach Position S1 invalid
VALELOGIC_ERROR_TEACH_2	ERROR	180a	Logic ERROR: Teach Position S2 invalid
VALELOGIC_ERROR_TEACH_3	ERROR	180b	Logic ERROR: Teach Position lift invalid
VALELOGIC_ERROR_TEACH_4	ERROR	180c	Logic ERROR: Teach Position S3 invalid
VALELOGIC_ERROR_TEACH_5	ERROR	180d	Logic ERROR: Teach Position S4 invalid
VALELOGIC_ERROR_TEACH_6	ERROR	180e	Logic ERROR: Teach External prox. Sensor signal invalid
VALELOGIC_ERROR_AIR_HIGH	ERROR	180f	ERROR: Air pressure too high
VALELOGIC_ERROR_AIR_LOW	ERROR	1810	ERROR: Air pressure too low
VALELOGIC_ERROR_IO_FAULT	ERROR	1811	ERROR: IO Fault
VALELOGIC_ERROR_MEMORY	ERROR	1812	ERROR: Memory
VALELOGIC_ERROR_VALVE_SETTING	ERROR	1813	ERROR: Valve Settings
VALELOGIC_ERROR_VOLTAGE_LOW	ERROR	1814	ERROR: Voltage to low
VALELOGIC_ERROR_VALVE_AMOUNT1	ERROR	1815	ERROR: Wrong amount (1) of solenoids
VALELOGIC_ERROR_VALVE_AMOUNT2	ERROR	1816	ERROR: Wrong amount (2) of solenoids
VALELOGIC_ERROR_VALVE_AMOUNT3	ERROR	1817	ERROR: Wrong amount (3) of solenoids
VALELOGIC_ERROR_PERIPHERY	ERROR	1818	ERROR: Periphery error
VALELOGIC_ERROR_EXT_VOLTAGE	ERROR	1819	ERROR: Wrong external voltage
PROX_SENSOR34_EQUAL	ERROR	181a	ERROR: External proximity switch. Signal Sensor3 and Sensor4 equal
PROX_SENSOR34_INTER	ERROR	181b	ERROR: External proximity switch. Signal Sensor3 and Sensor4 interchanged
PROX_SENSOR3_ERROR	ERROR	181c	ERROR: External proximity switch. Signal Sensor3
PROX_SENSOR4_ERROR	ERROR	181d	ERROR: External proximity switch. Signal Sensor4
LIN_SENSOR_OVERLAP_S1	ERROR	181e	ERROR: Overlap prea position S1
LIN_SENSOR_OVERLAP_S2	ERROR	181f	ERROR: Overlap area position S2
LIN_SENSOR_OVERLAP_LIFT	ERROR	1820	ERROR: Overlap area position LIFT
LIN_SENSOR_OVERLAP_S3	ERROR	1821	ERROR: Overlap area position S3
LIN_SENSOR_OVERLAP_S4	ERROR	1822	ERROR: Overlap area position S4

6. Electronic Module

6.9. Data signals

6.9.16. Events

ID	Event Type	Event Code	IODD Text
Service Events		HEX	
VALELOGIC_SERVICE_MAX_HOURS	NOTIFICATION	1840	Notification: Service interval max. hours reached
VALELOGIC_SERVICE_MAX_ACTIVATION_MAIN	NOTIFICATION	1841	Notification: Service interval max. strokes reached
VALELOGIC_SERVICE_MAX_ACTIVATION_TIME	NOTIFICATION	1842	Notification: Max. activation time exceeded
VALELOGIC_SERVICE_MAX_REACTION_TIME	NOTIFICATION	1843	Notification: Max. reaction time exceeded
VALELOGIC_SERVICE_MAX_DEACTIVATION_TIME	NOTIFICATION	1844	Notification: Max. deactivation time exceeded
VALELOGIC_SERVICE_MAX_REACTION_TIME_DE	NOTIFICATION	1845	Notification: Max. reaction time deactivation exceeded
VALELOGIC_SERVICE_MIN_AIR	NOTIFICATION	1846	Notification: Air pressure low
VALELOGIC_SERVICE_MAX_AIR	NOTIFICATION	1847	Notification: Air pressure high
VALELOGIC_SERVICE_EVENT	NOTIFICATION	1848	Notification: Service event occurred

6. Electronic Module

6.9. Data signals

6.9.16. Events

ID	Event Type	Event Code	IODD Text
Teach Events			
TEACH_ERROR_AIR_PRESSURE_LOW	ERROR	1880	Teach Error: Air pressure low
TEACH_ERROR_PROX_SWITCH	ERROR	1881	Teach Error: Proximity switch error
TEACH_ERROR_SENSOR1	ERROR	1882	Teach Error: Sensor 1
TEACH_ERROR_SENSOR2	ERROR	1883	Teach Error: Sensor 2
TEACH_ERROR_EMV1_WIRE_BREAK	ERROR	1884	Teach Error: Wire break solenoid 1
TEACH_ERROR_EMV1_SHORT_CIRCUIT	ERROR	1885	Teach Error: Short circuit solenoid 1
TEACH_ERROR_EMV2_WIRE_BREAK	ERROR	1886	Teach Error: Wire break solenoid 2
TEACH_ERROR_EMV2_SHORT_CIRCUIT	ERROR	1887	Teach Error: Short circuit solenoid 2
TEACH_ERROR_EMV3_WIRE_BREAK	ERROR	1888	Teach Error: Wire break solenoid 3
TEACH_ERROR_EMV3_SHORT_CIRCUIT	ERROR	1889	Teach Error: Short circuit solenoid 3
TEACH_ERROR_TOLERANCE_SENSOR1	ERROR	188a	Teach Error: Tolerance band error/overlap Sensor 1
TEACH_ERROR_TOLERANCE_SENSOR2	ERROR	188b	Teach Error: Tolerance band error/overlap Sensor 2
TEACH_ERROR_POSITION_SENSOR1	ERROR	188c	Teach Error: Position Sensor 1
TEACH_ERROR_POSITION_SENSOR2	ERROR	188d	Teach Error: Position Sensor 2
TEACH_END	NOTIFICATION	188e	Teach: Teach end
TEACH_START	NOTIFICATION	188f	Teach: Teach start.
TEACH_PRES_SENSOR_ABSENT	ERROR	1890	Teach: Pressure sensor absent.
TEACH_VALVE_CLOSE	NOTIFICATION	1891	Teach: Close valve. All actuators are deactivated.
TEACH_INFO_WAIT_POS_2	NOTIFICATION	1893	Teach: Activate main actuator (Solenoid 1).
TEACH_INFO_CLOSE_VALVE_1	NOTIFICATION	1894	Teach: Deactivate main actuator (Solenoid 1).
TEACH_INFO_WAIT_POS_1_1	NOTIFICATION	1895	Teach: Waiting for valve deactivated.
TEACH_INFO_OPEN_VALVE_2	NOTIFICATION	1896	Teach: Activate actuator 2 (Solenoid 2).
TEACH_INFO_WAIT_SEAT_UPPER	NOTIFICATION	1897	Teach: Wait until upper seatlift position is reached.
TEACH_INFO_CLOSE_VALVE_2	NOTIFICATION	1898	Teach: Deactivate Actuator 2 (Solenoid 2).
TEACH_INFO_WAIT_POS_1_2	NOTIFICATION	1899	Teach: Deactivate actuator 2. Waiting for valve position is reached.

6. Electronic Module

6.9. Data signals

6.9.16. Events

ID	Event Type	Event Code	IODD Text
Teach Events			HEX
TEACH_INFO_OPEN_VALVE_3	NOTIFICATION	189a	Teach: Activate actuator 3 (Solenoid 3).
TEACH_INFO_WAIT_SEAT_LOWER	NOTIFICATION	189b	Teach: Waiting for lower seatlift position is reached.
TEACH_INFO_CLOSE_VALVE_3	NOTIFICATION	189c	Teach: Deactivate actuator 3 (Solenoid 3).
TEACH_INFO_WAIT_POS_1_3	NOTIFICATION	189d	Teach: Deactivate actuator 3. Waiting for valve position is reached.
TEACH_INFO_OK	NOTIFICATION	189e	Teach: OK
TEACH_ERROR	ERROR	189f	Teach Error!
TEACH_INFO_CANCEL	NOTIFICATION	18a0	Teach: Teach canceled
TEACH_INFO_SAVE	NOTIFICATION	18a1	Teach: Save all parameters in EEPROM.
TEACH_TIMEOUT	ERROR	18a2	Teach Error: Timeout
TEACH_STORE_SENSOR1_S1	NOTIFICATION	18a3	Teach: Record Sensor 1 Position 1
TEACH_STORE_SENSOR1_S2	NOTIFICATION	18a4	Teach: Record Sensor 1 Position 2
TEACH_STORE_SENSOR1_LIFT	NOTIFICATION	18a5	Teach: Record Sensor 1 Position Lift
TEACH_STORE_SENSOR1_OFS	NOTIFICATION	18a6	Teach: Record Sensor 1 offset
TEACH_STORE_SENSOR2_OFS	NOTIFICATION	18a7	Teach: Record Sensor 2 offset
TEACH_SENSOR1_OUT_OF_RANGE	NOTIFICATION	18a8	Teach: Sensor 1 out of range
TEACH_SENSOR2_OUT_OF_RANGE	NOTIFICATION	18a9	Teach: Sensor 2 out of range
TEACH_STORE_SENSOR2_S3	NOTIFICATION	18aa	Teach: Record Sensor 2 Position 3
TEACH_STORE_SENSOR2_S4	NOTIFICATION	18ab	Teach: Record Sensor 2 Position 4

6. Electronic Module

6.9. Data signals

6.9.16. Events

ID	Event Type	Event Code	IODD Text
Teach Closed Position Events			
		HEX	
TEACH_CLOSED_NC_DONE	NOTIFICATION	18c0	Teach closed: Teach Closed Position (NC) end
TEACH_CLOSED_NO_DONE	NOTIFICATION	18c1	Teach closed: Teach Closed Position (NO) end
TEACH_CLOSED_SAVE_S1	NOTIFICATION	18c2	Teach closed: Record Position S1
TEACH_CLOSED_SAVE_S2	NOTIFICATION	18c3	Teach closed: Record Position S2
TEACH_CLOSED_SAVE_S3	NOTIFICATION	18c4	Teach closed: Record Position S3
TEACH_CLOSED_SAVE_S4	NOTIFICATION	18c5	Teach closed: Record Position S4
TEACH_CLOSED_START	NOTIFICATION	18c6	Teach closed: Teach closed Position start
TEACH_CLOSED_ERROR_EMV_ON	ERROR	18c7	Teach closed Error: Valve in wrong position. Main actuator should be not activated
TEACH_CLOSED_ERROR_EMV_OFF	ERROR	18c8	Teach closed Error: Valve in wrong position. Main actuator should be activated
TEACH_CLOSED_ERROR_UNKNOWN	ERROR	18c9	Teach closed Error: Error unknown.
TEACH_STORE_SENSOR2_S4	NOTIFICATION	18ab	Teach: Record Sensor 2 Position 4

ID	Event Type	Event Code	IODD Text
Special for IO-Link device test			
		HEX	
TEST_EVENT_A	ERROR	8DFE	
TEST_EVENT_B	ERROR	8DFF	
parameter_error	ERROR	6320	
DS_UPLOAD_REQUEST	NOTIFICATION	FF91	

6. Electronic Module

6.10. Data Storage Mode / Firmware Update

6.10.1. Data Storage Mode

The Data Storage (DS) mechanism enables the consistent and up-to-date buffering of the CU4plus IO-Link device parameters on upper levels like PLC programs or fieldbus parameter server. Data Storage between Masters and Devices is specified according the IO-Link standard, whereas the adjacent upper data storage mechanisms depend on the individual fieldbus or system. The CU4plus IO-Link holds all for an device exchange needed parameters for Data Storage.

CU4 plus supports all IO-Link target modes such as SCAN, TYPE COMPATIBLE and IDENTICAL mode.

For the proper operation of the IDENTICAL mode the IODD file must be extended with the serial number of the electronic module. One example:

```
<StdVariableRef id="V_SerialNumber"  
defaultValue="H344393TEST001"/>
```

For the backup level DISABLE, RESTORE and BACKUP/ RESTORE are supported.

Note that the Master needs the information of 'Vendor ID' and 'Device ID' for the target modes TYPE COMPATIBLE and IDENTICAL.

6.10.2. Firmware Update

High complex software products and devices which use complex software, need to be updated from time to time. IO-Link defines a mechanism for an update of firmware. This update can be done by an IO-Link master which supports this update mechanism.

New firmware for a CU4plus IO-Link is supplied as file with the ending *.iolfw. The complete firmware is inside this file encrypted with all required data.

This *.iolfw file can be read from an IO-Link master and transferred by the Master to the CU4plus.

A bootloader is implemented in the electronic module. This bootloader handles the firmware update. The bootloader is started by the master and writes the bytes transferred into the non-volatile Flash memory of the CU4plus.

The memory in which the bootloader is stored is not erased during this procedure. This means if errors occur during the transfer (electrical power blackout, PLC blackout ...), the bootloader in the electronic module always starts the control unit and the firmware update can be started once again.

6. Electronic Module

6.11. Seat Pulsation - Efficiency in Cleaning

For increasing seat cleaning efficiency there is a function called "Pulsation". With this function, the seat lifts can be operated in pulsation mode if the PLC signal activates the seat lift.

For the pulsation the ON and OFF time can be adjusted.

Parameters, see table in chapter 6.8.17.

The selection of the pulsation times must be done in accordance with the process situation and the appropriate valve size. The selected times must ensure complete opening and closing of the seats.

We recommend adjusting the time for "pulse off" to be larger than 30 seconds.

When the seat pulsation is activated, with the 1st seat lifting (pulse on), the feedback signal for the appropriate seat lift will be active.

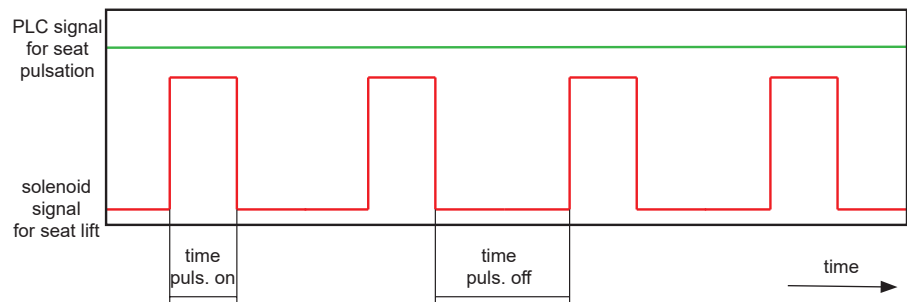

6. Electronic Module

6.12. Service and Maintenance Software CU4plus Toolbox



For the parameterization of the CU4plus IO-Link the CU4plus Toolbox Software for PC is available. This is an alternative to the parameterization with the IO-Link connection. All parameters can be read and set in both ways.

The Toolbox kit with appropriate USB/serial cable can be purchased from SPX FLOW using the article number H333470.

The latest Software version is always available from the SPX FLOW F&B Sharepoint. Please contact your SPX FLOW Sales representative.

The software is designed for PC systems with Windows® operating system. The PC is connected via the USB/serial cable to the service interface of the electronic module. Power must be connected to the module.

The individual functions are described in the CU4plus Toolbox manual.

6.13. Data Acquisition and BLOB Data Transfer

6.13.1. Data Acquisition

For predictive maintenance and observation of the valve, all sensor signals of a valve switch are stored in the internal RAM of the control unit. The start point (trigger) is always a switch of one solenoid. The duration of the measurement and a delay or skip of measurements can be adjusted by two parameters.

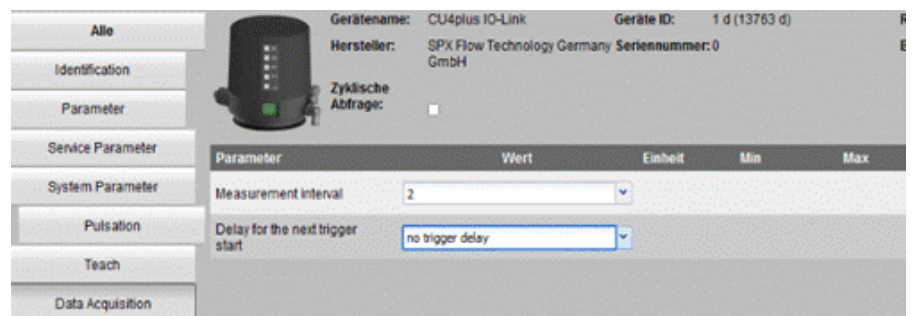

With parameter "Measurement interval" the time in seconds of one measurement can be adjusted. Every record has a length of 200 measurement points. For an adjusted measurement time of 2 seconds a measurement takes place every 10 ms. With parameter "Delay for the next trigger start" the time from one to the next data acquisition can be increased. A delay up to 180 days, half a year is possible.

For further information to the parameters see chapter 6.9.20.

6. Electronic Module

6.13. Data Acquisition and BLOB Data Transfer

6.13.2. Data Transfer

All measured data can be transferred with the Binary Large Object mechanism from IO-Link via the IO-Link master to a PC. For this data transfer the IO-Link parameter “Data transfer BLOB” exists.

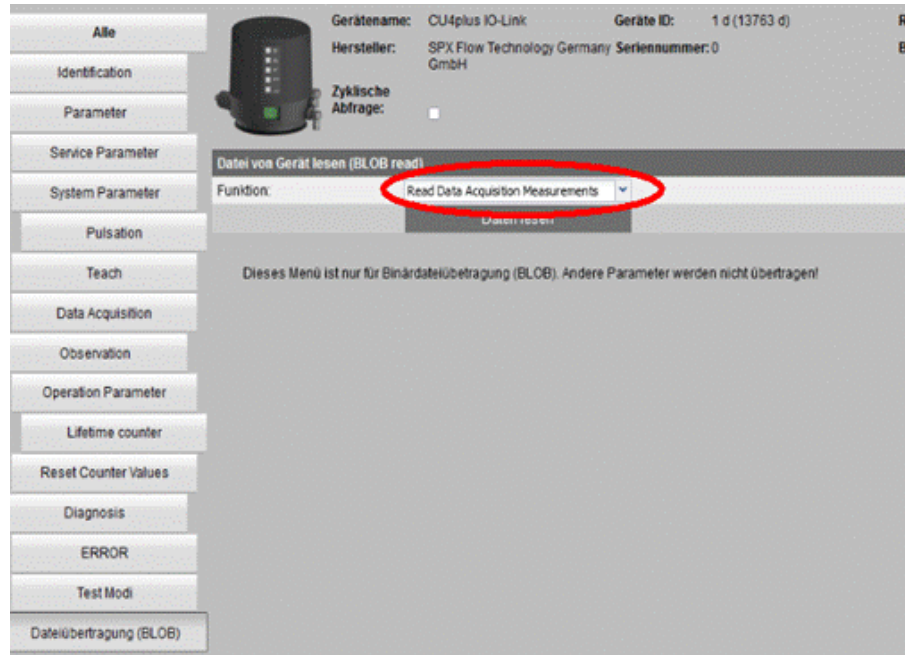

Here the function “Read Data Acquisition Measurements” can be selected, and the data be stored to a PC. This is a transfer of binary data, but in this case the data are ‘coma separated values’. This means that the output file can be stored as *.csv file. This kind of data can be read by many PC programs, e.g. excel, gnuplot or every text editor.

Four data sets are available. These are “Process Data Set 0” to “Process Data Set 3”. And also a dataset for teach “TEACH Data”.

6.9.3. Data Format

The data are split up into the following blocks:

Data Set 0

Data Set 1

Data Set 2

Data Set 3

Teach Data

6. Electronic Module

6.13. Data Acquisition and BLOB Data Transfer

6.13.3. Data Format

Each Block of Data Set has this format:

Description	Data
Header Description	operatingHours; emv1Strokes;emv2Strokes; emv3Strokes;LastActivationTime; LastReactionTimeAct; LastDeactivationTime; LastReactionTimeDeact; Interval
Data Set Header	<9 separated values>
Data Header	shaftPosition1; shaftPosition2; airPressure; digitalOutputs; digitalInputs
Data	200*<5 separated values>

Format of Teach Data Block:

Description	Data
Header Description	operatingHours; emv1Strokes; emv2Strokes; emv3Strokes; LastActivationTime; LastReactionTimeAct; LastDeactivationTime; LastReactionTimeDeact; Interval
Data Set Header	<9 separated values>
	shaftPosition1; shaftPosition2; airPressure; digitalOutputs
Start Valve Open Measurements	Valve open values
Data	200*<4 separated values>
Start Valve Closing Measurements	Valve closing values
Data	200*<5 separated values>

6. Electronic Module

6.13. Data Acquisition and BLOB Data Transfer

Digital Input Data Bits

The digital input bits are combined to a hexadecimal digit. This table shows the bit conversion.

Bit	15	14	13	12	11	10	9	8
Hex	0x8000	0x4000	0x2000	0x1000	0x0800	0x0400	0x0200	0x0100
Description		Sensor Position 4	Sensor Position 43		Sensor Position 2	Sensor Position 1		
Bit	7	6	5	4	3	2	1	0
Hex	0x0080	0x0040	0x0020	0x0010	0x0008	0x0004	0x0002	0x0001
Description					Lower seat lift active	Upper seat lift active	Valve open	Valve closed

Digital Output Data Bits

The digital output bits are also a combination displayed as hexadecimal digit. Bit conversion as follows:

Bit	7	6	5	4	3	2	1	0
Hex	0x80	0x40	0x20	0x10	0x08	0x04	0x02	0x01
Description	-	-	-	-	-	Lower seat lift	Upper seat lift	Main Valve

6. Electronic Module

6.14. Valve Monitoring

For a monitoring of the valve movement the “Valve Monitoring” function can be used. For each actuator movement a time limit can be adjusted. The valve controller monitors the movement time. Is the movement of the valve higher than the adjusted time, an error flag is set. This error can be read from the process data input signals.

The monitor times for each solenoid can be set with the ‘Monitor Parameters’ The default of each monitoring time is set to 2000ms. For each solenoid there is a on- and off- switching time to select.

Parametername	Wert	Derzeitiger Gerätewert	Minimum	Maximum
Monitor Parameter				
EMV1 ON time monitor	2000 ms	2000 ms	0 ms	65535 ms
EMV1 OFF time monitor	2000 ms	2000 ms	0 ms	65535 ms
EMV2 ON time monitor	2000 ms	2000 ms	0 ms	65535 ms
EMV2 OFF time monitor	2000 ms	2000 ms	0 ms	65535 ms
EMV3 ON time monitor	2000 ms	2000 ms	0 ms	65535 ms
EMV3 OFF time monitor	2000 ms	2000 ms	0 ms	65535 ms

With the ‘Monitor Measurements’ the current time for the last movement can be read out. This indication can help to select a limit and find problems with the valve.

Parametername	Wert	Derzeitiger Gerätewert	Minimum	Maximum
Monitor Measurements				
EMV1 ON time monitor	0 ms	0 ms	0 ms	65535 ms
EMV1 OFF time monitor	0 ms	0 ms	0 ms	65535 ms
EMV2 ON time monitor	0 ms	0 ms	0 ms	65535 ms
EMV2 OFF time monitor	0 ms	0 ms	0 ms	65535 ms
EMV3 ON time monitor	0 ms	0 ms	0 ms	65535 ms
EMV3 OFF time monitor	0 ms	0 ms	0 ms	65535 ms
Valve Monitor	<input type="button" value="Reset Valve Mon..."/>			

If the movement time was higher than the specified limit this is shown with process output parameter ‘Valve Monitor error’. This parameter can show the following values:

- Bit 0 (0x01) EMV1 on error
- Bit 1 (0x02) EMV1 off error
- Bit 3 (0x04) EMV2 on error
- Bit 4 (0x08) EMV2 off error
- Bit 5 (0x10) EMV3 on error
- Bit 6 (0x20) EMV3 off error

A combination of this values can also happen. E.g. an exceed of the on movement opening and closing time of a valve with solenoid 1 shows Bit 0 and Bit 1 = 0x03 = 3 dez.

The error value is still available until the next valve switch. Or the error value can be reset with the ‘Reset Valve Monitor Error’ function.

This valve monitor function doesn’t work with the levers at the solenoids!

6. Electronic Module

6.14. Valve Monitoring

6.14.1 Valve Monitor Parameter

Name	Index	Subindex	Rights	Type	Unit
EMV1 ON time monitor	139	0	RW	Unsigned integer	ms
EMV1 OFF time monitor	140	0	RW	Unsigned integer	ms
EMV2 ON time monitor	141	0	RW	Unsigned integer	ms
EMV2 OFF time monitor	142	0	RW	Unsigned integer	ms
EMV3 ON time monitor	143	0	RW	Unsigned integer	ms
EMV3 OFF time monitor	144	0	RW	Unsigned integer	ms

6.14.2 Valve Monitor Measurements

Name	Index	Subindex	Rights	Type	Unit
EMV1 ON time monitor	145	0	RW	Unsigned integer	ms
EMV1 OFF time monitor	146	0	RW	Unsigned integer	ms
EMV2 ON time monitor	147	0	RW	Unsigned integer	ms
EMV2 OFF time monitor	148	0	RW	Unsigned integer	ms
EMV3 ON time monitor	149	0	RW	Unsigned integer	ms
EMV3 OFF time monitor	150	0	RW	Unsigned integer	ms
Reset Valve Monitor Error	151	0	WO	Button	

6.14.3 Time based pulsation

Name	Index	Subindex	Rights	Type	Unit
Pulse time on main actuator	120	0	RW	Unsigned integer	1/10 s
Pulse time off main actuator	121	0	RW	Unsigned integer	1/10 s
Pulse time on upper SL	70	0	RW	Unsigned integer	1/10 s
Pulse time off upper SL	71	0	RW	Unsigned integer	1/10 s
Pulse time on lower SL	72	0	RW	Unsigned integer	1/10 s
Pulse time off lower SL	73	0	RW	Unsigned integer	1/10 s

6.14.4 Position based pulsation

Name	Index	Subindex	Rights	Type	Unit
Position controlled pulsation	119	0	RW	Boolean	
Position controlled Pulsation on time main actuator	136	0	RW	Unsigned integer	s
Position controlled Pulsation on time upper seatlift	137	0	RW	Unsigned integer	s
Position controlled Pulsation on time lower seatlift	138	0	RW	Unsigned integer	s
Pulse movement change position main actuator	122	0	RW	Unsigned integer	%
Pulse movement change position upper seat lift	106	0	RW	Unsigned integer	%
Pulse movement change position lower seat lift	107	0	RW	Unsigned integer	%

7. Valve Position Indication

7.1. Continuously measuring valve position measuring system

For the internal detection of the valve position indication, a contact-free operating linear sensor is used which is actuated via the magnetic switching cam installed at the valve rod. The nominal measuring range of the measuring system amounts to 0 - 72 mm, relative repetitive accuracy < 0.1 mm.

Within this measuring range, the corresponding positions for closed and open valve position as well as seat lift positions are generated via the Teach-in function and permanently saved in the electronic.

7.2. Tolerance band of the valve position measuring system

The tolerance band of the valve position measuring system describes the active measuring range in which the corresponding feedback information, closed or open valve position, is registered. For different process valves also different tolerance bands exist. The adjustment is realized via the ToolBox software.

Tolerance band	Output of feedback signals in range	Recommendation for valve type
T1	+/- 1 mm	e.g.D4, D4 SL

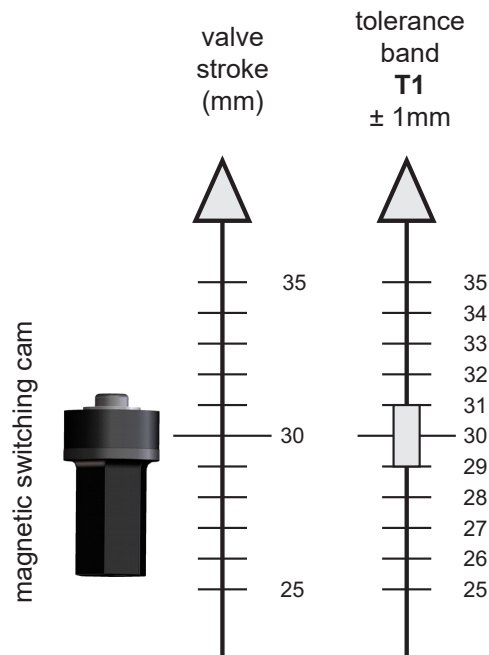

7. Valve Position Indication

7.3. Adjustment of valve position indication / Teach-in

The continuously measuring valve position measuring system is taught via a reference valve movement.

The respective positions for the closed and open valve position as well as for further valve positions, e.g. seat lifting, are travelled to and the corresponding position of the sensor system is permanently stored in the memory of the electronic module. This process is called Teach-in.

The Teach-in is started by pressing the Teach-in key at the electronic module or by using the parameter "Complete automatic teach function" over IO-Link (FW-V2.00 or later). The key must be pressed permanently for 3 seconds.

After the start of the Teach-in the LED 9 lights up and the valve travels into the corresponding final positions and back into the basic position. The positions of the corresponding valve positions are stored.

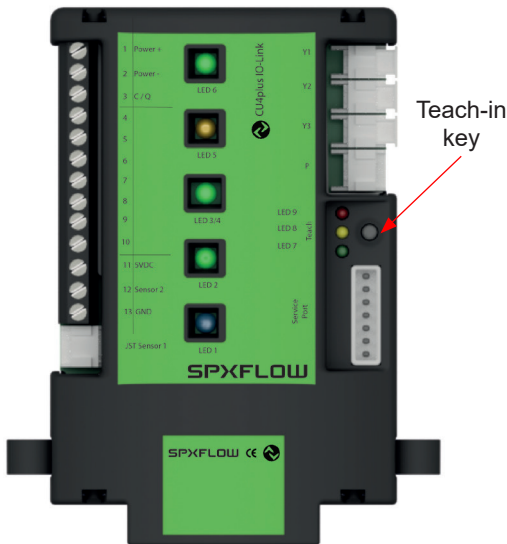

Indication	Status	Action
LED 3-6,9 blink	Delivery status Waiting for Teach-in	Start Teach-in press Teach-in for at least 3 seconds
LED 9 ON LED 3/4 blink	Teach-in active	Wait Do not control valve via PLC.
LED 9 OFF	Successful Teach-in	Valve can be controlled by PLC.
LED 9 ON	Valve Teach carried out	Wait for Teach result
LED 9 blink	Teach-in not successful, repetition required. Possible reasons for Teach-in failure: Compressed air is missing. Supply voltage missing. Switching logic does not fit to valve.	Start Teach-in / press Teach-in key for 3 sec. Check the tech events occurred at the IO-Link master to diagnose the failure.

7. Valve Position Indication

7.3.1 Teach-in hour log

The teach time/hour from the life time hour counter is stored in the parameter "Teach hour log". This function records the time stamp corresponding to the moment when the teaching process was executed.

Quelle	Parametername	Wert	Derzeitiger Gerätewert	Minimum	Maximum	Beschreibung
Teach	Teach Closed Position					Teach Closed Position
Teach	Complete automatic teach function					Complete automatic teach function
Teach hour log		0 h	0 h	0 h	4294967295 h	Teach hour counted from lifetime hours)

7.4 Teach closed position

If required, the closed position of a valve can be calibrated separately. The IO-Link parameter "Teach Closed Position" index 94 starts this function.

The assumption of this function is that the valve is closed. This means that all solenoid valves are off for a N.C. (normally closed) valve or the main solenoid valve is activated for a valve with N.O. (normally open) functionality.

7. Valve Position Indication

7.5. To be observed before Teach-in:

- Corresponding switching cam is mounted to the valve guide rod.



Note! Caution!

The switching cam is not identical with the standard CU switching cam!

- CU4plus IO-Link control unit is not duly installed on the valve.
- Valve is duly installed in the process.
- **Valve is not manually controlled or controlled by PLC.**
- Control air is connected (requirements, see Technical Data, chapter 4.5.).
- Nominal valve stroke is not restricted, e.g. through chunky products in the valve.
- Selected switching logic complies with the installed process valve (adjustment is realized via CU4plus Toolbox software, delivery status is switching logic for DA4).

During the Teach-in function, the valve is controlled and moves independently into all operating positions.

As a precaution, the Teach-in function is to be repeated after any valve service or maintenance!



If these instructions are not observed, process failures, product loss or personal injury may occur!

7.6. Use of external sensors

For double seat valves with active seat lift detection (SLD) 2 additional proximity switches are required which are mounted in the actuator area of the DA3+ valve and connected at the electronic module of the CU4plus IO-Link.

8. CU Assembly and Startup

8.1. Double seat mix proof valves D4, D4 SL

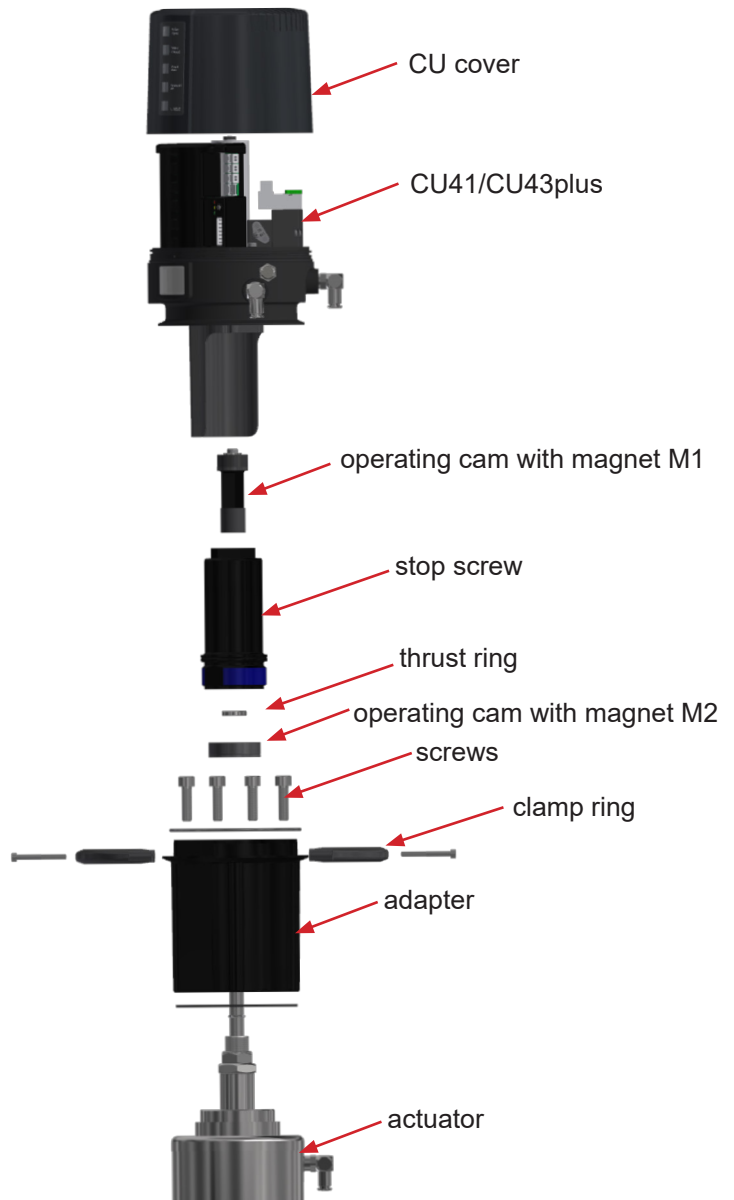
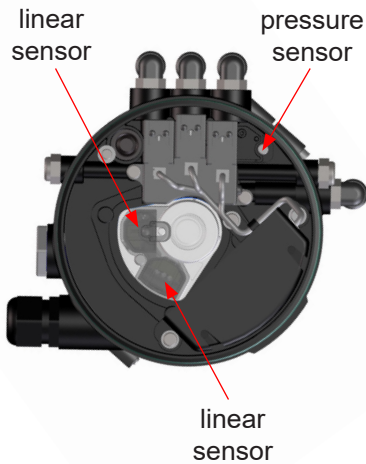

Assembly of the control unit on the valve

1. Take off the stop screw and thrust ring.
2. Assemble the magnet M2 on the upper shaft.
3. Reassemble the thrust ring and stop screw.
4. Assemble the adapter with the 4 screws on the double seat valve.
5. Assemble the operating cam M1 with guide rod extension on the guide rod.
6. Place the control unit onto the adapter. Observe alignment!
7. Attach the clamp rings and fasten them with the 2 screws.
8. Attach air connections of the control unit to the valve actuator.

8. CU Assembly and Startup

8.1.1 Pneumatic connection



Supply air:

Caution!

Shut off the compressed air supply before connecting the air hose!

Make sure that the air hose is professionally cut to length. Use a hose cutter for this purpose.

Pneumatic air to valve actuator:

Connect pneumatic air connection **Y1** with the valve actuator, air connection 1 - main stroke

Connect pneumatic air connection **Y2** with the valve actuator, air connection 2 - upper seat lifting

Connect pneumatic air connection **Y3** with the valve actuator, air connection 3, lower seat lifting

Exhaust air:

As a standard, the exhaust air connections **A1** and **A2** are equipped with a silencer. If required, the silencer can be removed and the exhaust air can be hosed separately when it must be led off to the exterior, for example.

8.4.2 Electric connection



Attention! Electric connections shall only be carried out by qualified personnel.

Observe the Safety Instructions specified in chapter 2.

8. CU Assembly and Startup

**solenoid valve
block 3**

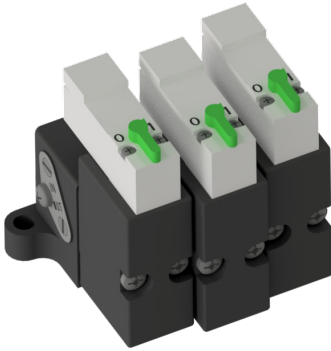

8.1.3 Connection of external proximity switches

The electric connection of the proximity switches specified by SPX FLOW is undertaken according to the terminal layout described in chapter 6.

The mechanic assembly of the proximity switches is carried out at the actuator of the corresponding double seat valves. Observance of the instruction manual for double seat valves is essential!

8.1.4 Startup

After proper assembly and installation of the control unit, startup can be undertaken as described below

1. Switch on the air supply
2. Switch on the voltage supply.
3. Check the solenoid valves by turning the lever on the upper side by 90°.
4. Select Valve Type:
Type 1 D4
Type 2 D4 SL
5. For final adjustments of the feedback position switches please use the Teach function.

9. Accessories and Tools

Assembly/disassembly - adapter on valve actuator:

- hexagon socket wrench 6 mm
- screwdriver 4 mm

Assembly/disassembly – CU on adapter:

- hexagon socket wrench 3 mm

Assembly/disassembly – electronic module:

- Torx wrench TX20
- screwdriver 3.5 mm

Assembly/disassembly – feedback unit:

- Torx wrench TX15

Assembly/disassembly – electronic modules:

- Torx wrench TX20

Assembly/disassembly – air connections:

- jaw wrench SW13

Assembly/disassembly – pressure relief valve:

- Torx wrench TX10

Loctite semi-solid

jaw wrench



torx wrench



screwdriver



hexagon socket wrench

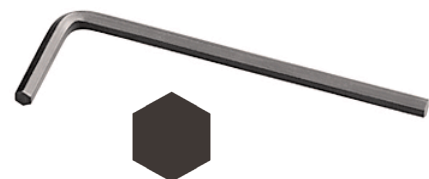

10. Service

10.1. Dismantling

Before disassembly, verify the following items:

- The valve must be in safety position and must not be controlled!
- Shut off air supply!
- Cut off current to control unit, i.e. interrupt the supply voltage!

Solenoid valve (4, 5, 6)

- + Open the CU cover by turning in counterclockwise direction.
- + Release the plug connection at the electronic module for the corresponding solenoid valve.
- + Release and remove the 2 screws (20) TX20.
- + Replace the solenoid valve.
- + Assembly in reverse order. See to a proper fit of the flat seal!

Electronic module (2)

Before releasing the cable connections make sure that all lines are de-energised!

- + Open the CU cover by turning in counterclockwise direction.
- + Release the plug connection of the solenoid valves.
- + Release the cable from the terminal strip, all terminals 1-8.
- + Release and remove the 3 screws (20) TX20.
- + Replace the electronic module.
- + Assembly in reverse order.

Feedback unit

Before releasing the cable connections make sure that all lines are de-energised!

- + Open the cover.
- + Release the cable for the linear sensors from the terminal strip, terminals 3-8.
- + Release the clamp ring and lift the CU4 from the adapter.
- + Remove the 4 screws (9) TX15 at the lower side of the CU base (1).
- + Take out the feedback unit to the bottom.

Linear sensor

The linear sensor can only be replaced at the dismantled feedback unit.

- + Remove the 2 screws (14) TX10.
- + Release the plug connection at the electronic module.
- + Dismantle the linear sensor.
- + Assembly in reverse order.
- + Carry out Teach-in.

11. Trouble Shooting

Failure	Remedy
Valve position is not indicated.	Carry out Teach-in.
	Check fastening of magnetic switching cam.
	Check adjusted logic profile and process valve.
Feedback via proximity switches is missing.	Check positioning of proximity switches.
	Check cabling to the electronic module.
LED indication is missing.	Check cabling to the electronic module.
Control Unit CU41 installed on Single seat, Double seal and Double seat valves without seat lifting	
Valve position movement is missing with actuated solenoid valve.	Check if right control unit is installed. Check label in type window of control unit: CU41plus-D4 IO-Link
	Check valve movement with manual at solenoid valve.
	Check cabling between electronic module and solenoid valve.
	Check compressed air (min. 6 bar) (D4 - min. 5 bar).
	Check control air connection between the CU41 and the valve actuator.
Control Unit CU43 installed on Double seat valves with seat lifting	
Valve position movement is missing with actuated solenoid valve.	Check if right control unit is installed. Check label in type window of control unit: CU43plus-D4 IO-Link
	Check valve movement with manual at solenoid valve.
	Check cabling between electronic module and solenoid valve
	Check compressed air (min. 6 bar) (D4 - min. 5 bar).
	Check control air connection between the CU43plus and the DA4 / D4 SL actuator.

12. IECEX / CCC Certificate of Conformity

Please see attchement.

13. Spare Parts Lists

The reference numbers of spare parts for the different control unit designs and adapters are included in the attached spare parts drawings with corresponding lists.

When you place an order for spare parts, please indicate the following data:

- number of parts required
- ID number
- reference number
- parts designation

Data are subject to change.



IECEX Certificate of Conformity

INTERNATIONAL ELECTROTECHNICAL COMMISSION IEC Certification System for Explosive Atmospheres

for rules and details of the IECEx Scheme visit www.iecex.com

Certificate No.:	IECEX TUN 22.0020X	Page 1 of 3	Certificate history:
Status:	Current	Issue No: 0	
Date of Issue:	2023-09-11		
Applicant:	SPX Flow Technology Germany GmbH Gottlieb-Daimler-Str. 13 59439 Holzwickede Germany		
Equipment:	Control unit resp. Double seat valve resp. Assembly		
Optional accessory:	Control unit type CU4** resp. CU4*plus* resp. Double seat valve type D4* resp. Assembly type D4*-CU4**/CU4*plus* 3G		
Type of Protection:	Equipment protection by increased safety "ec"; Non-electrical equipment for explosive atmospheres		
Marking:	Control unit type CU4** resp. CU4*plus*: Ex ec IIB T4 Gc Double seat valve type D4*: Ex h IIB T6...T4 Gb Assembly type D4*-CU4** / D4*-CU4*plus*3G: Ex ec h IIB T4 Gc		

Approved for issue on behalf of the IECEx
Certification Body:

Thomas Heinen

Position:

Deputy Head of the IECEx Certification Body

Signature:
(for printed version)

TUVNORD

Digital unterschrieben
von Heinen Thomas
Datum: 2023.09.11
12:48:33 +02'00'

Date:
(for printed version)

1. This certificate and schedule may only be reproduced in full.
2. This certificate is not transferable and remains the property of the issuing body.
3. The Status and authenticity of this certificate may be verified by visiting www.iecex.com or use of this QR Code.



Certificate issued by:

TÜV NORD CERT GmbH
Hanover Office
Am TÜV 1, 30519 Hannover
Germany





IECEX Certificate of Conformity

Certificate No.: **IECEX TUN 22.0020X**

Page 2 of 3

Date of issue: 2023-09-11

Issue No: 0

Manufacturer: **SPX Flow Technology Germany GmbH**
Gottlieb-Daimler-Str. 13
59439 Holzwickede
Germany

Manufacturing locations: **SPX Flow Technology Germany GmbH**
Gottlieb-Daimler-Str. 13
59439 Holzwickede
Germany

SPX Flow Technology Poland Sp. z o.o.
Rolbieskiego 2
Bydgoszcz 85-862
Poland

This certificate is issued as verification that a sample(s), representative of production, was assessed and tested and found to comply with the IEC Standard list below and that the manufacturer's quality system, relating to the Ex products covered by this certificate, was assessed and found to comply with the IECEx Quality system requirements. This certificate is granted subject to the conditions as set out in IECEx Scheme Rules, IECEx 02 and Operational Documents as amended

STANDARDS :

The equipment and any acceptable variations to it specified in the schedule of this certificate and the identified documents, was found to comply with the following standards

[IEC 60079-0:2017](#) Explosive atmospheres - Part 0: Equipment - General requirements
Edition:7.0

[IEC 60079-7:2017](#) Explosive atmospheres - Part 7: Equipment protection by increased safety "e"
Edition:5.1

[ISO 80079-36:2016](#) Explosive atmospheres - Part 36: Non-electrical equipment for explosive atmospheres - Basic methods and requirements
Edition:1.0

[ISO 80079-37:2016](#) Explosive atmospheres - Part 37: Non-electrical equipment for explosive atmospheres - Non electrical type of protection constructional safety "c", control of ignition source "b", liquid immersion "k"
Edition:1.0

This Certificate **does not** indicate compliance with safety and performance requirements other than those expressly included in the Standards listed above.

TEST & ASSESSMENT REPORTS:

A sample(s) of the equipment listed has successfully met the examination and test requirements as recorded in:

Test Report:

[DE/TUN/ExTR22.0018/00](#)

Quality Assessment Report:

[DE/TUN/QAR18.0002/02](#)



IECEX Certificate of Conformity

Certificate No.: **IECEX TUN 22.0020X**

Page 3 of 3

Date of issue: 2023-09-11

Issue No: 0

EQUIPMENT:

Equipment and systems covered by this Certificate are as follows:

Description:

The control unit type CU4** resp. CU4*plus* is provided for controlling process valves in hazardous areas, it used as an interface between the process control and the process valve and operates the electrical and pneumatic signals.

The double seat valve type D4* used to process two different fluids efficiently through the valve simultaneously.

The assembly type D4*-CU4**/CU4*plus*3G is consisted of the electrical control unit CU4** resp. CU4*plus* and the non-electrical double seat valve type D4*.

Type code, electrical and thermal data:

See attachment to IECEx TUN 22.0020X issue No.0

SPECIFIC CONDITIONS OF USE: YES as shown below:

1. For the control unit type CU4** resp. CU4*plus* the permissible ambient temperature range during operation is $0\text{ }^{\circ}\text{C} \leq T_a \leq +55\text{ }^{\circ}\text{C}$

For the double seat valve type D4* the permissible ambient temperature range depending on the temperature class is the medium or cleaning solution's temperature and is to be taken from the operating instructions.

For the assembly type D4*-CU4** / D4*-CU4*plus* 3G the permissible ambient temperature range during operation at the control unit type CU4** resp. CU4*plus* is $0\text{ }^{\circ}\text{C} \leq T_a \leq 55\text{ }^{\circ}\text{C}$ and on the double seat valve type D4* is $0\text{ }^{\circ}\text{C} \leq T_a \leq +130\text{ }^{\circ}\text{C}$

2. Metallic process connection parts of the double seat valve type D4* have to be included in the local potential equalization.
3. The control unit CU4** resp. CU4*plus* and the plastic base of the double seat valve type D4* have to be installed and used in such a way, that electrostatic charging from operation, maintenance and cleaning is excluded.
4. The base of the control unit CU4** resp. CU4*plus* has to be installed in such a way that it is protected from UV-radiation.
5. The connecting and disconnecting of the pluggable electrical circuits inclusive the field wirings is only permitted if no explosive atmosphere exists
6. The control unit type CU4** resp. CU4*plus* has to be erected in such a way that a pollution degree 2 or better, according to IEC 60664-1, is achieved.
7. Measures have to be taken, external to the control unit type CU4** resp. CU4*plus*, to provide a transient protection that ensures that the rated voltage, connected to the power supply terminals, is not exceeded by more than 40%
8. To prevent the breaking of the springs, the actuator has to be replaced after 250,000 cycles.

Annex:

[Attachment to IECEx TUN 22.0020X issue No.0.pdf](#)

Page 1 of 5
Attachment to IECEx TUN 22.0020X issue No.: 0

General product information:

Description:

The control unit type CU4** resp. CU4*plus* is provided for controlling process valves in hazardous areas, it used as an interface between the process control and the process valve and operates the electrical and pneumatic signals.

The double seat valve type D4* used to process two different fluids efficiently through the valve simultaneously.

The assembly type D4*-CU4**/CU4*plus*3G is consisted of the electrical control unit CU4** resp. CU4*plus* and the non-electrical double seat valve type D4*.

Type code:

Control unit type CU4* *		
		AS-interface 24V Direct Connect
		1: 1 solenoid 1N: 1 solenoid, 1NOT element 3: 3 solenoids

Control unit type CU4* plus*		
		AS-interface 24V Direct Connect 24V IO-Link
		1: 1 solenoid 1N: 1 solenoid, 1NOT element 3: 3 solenoids

Double seat valve type D4*		
		NSL: Non Seat Lift SL: Seat Lift

Marking:

Control unit type CU4** resp. CU4*plus*	Ex ec IIB T4 Gc
Double seat valve type D4*	Ex h IIB T6...T4 Gb
Assembly type D4*-CU4** / D4*-CU4*plus*3G	Ex ec h IIB T4 Gc

Page 2 of 5
Attachment to IECEx TUN 22.0020X issue No.: 0

Electrical data:

For the control unit type CU4* plus AS-interface

Internal / External	Terminal	Designation	Functional description
External	1	AS-i +	Connection AS-i network (26.5 V...31.6 V d.c.)
External	2	AS-i -	Connection AS-i network (GND)
Internal	3	Z +	Bridge Z+ / PELV E+ (in case of energy supply for solenoid valves via AS-i bus)
Internal	4	Z -	Bridge Z- / PELV E - (in case of energy supply for solenoid valves via AS-i bus)
Internal	5	PELV E+	Separate auxiliary energy PELV 24VDC + (for EMERGENCY STOP function, only)
Internal	6	PELV E-	Separate auxiliary energy PELV 24VDC - (for EMERGENCY STOP function, only)
Internal	7	5 VDC	Voltage supply for proximity switches
Internal	8	Sensor 3	Signal sensor 3 (evaluation of logic table for appropriate valve type) for the control unit type CU4* AS-interface V1 resp. CU4* AS-interface V1 plus
		No sensor	For the control unit type CU4* AS-interface V2 resp. CU4* plus AS-interface V2
Internal	9	GND	Mass potential for sensor voltage supply
Internal	10	5 VDC	Voltage supply for proximity switches
Internal	11	Sensor 4	Signal sensor 4 (evaluation of logic table for appropriate valve type)
Internal	12	GND	Mass potential for sensor voltage supply
Internal	Linear sensor		Linear sensor for valve position detection (for suitable SPX FLOW sensor, only!)
Internal	Y1	--	Solenoid valve 1 (main valve)
Internal	Y2	--	Solenoid valve 2 (upper seat lift)
Internal	Y3	--	Solenoid valve 3 (lower seat lift)
Internal	P	--	Optional connection - pressure sensor
External	Service port	--	Connection serial/USB converter for CU4plus toolbox software

Page 3 of 5
Attachment to IECEx TUN 22.0020X issue No.: 0

For the control unit type CU4* plus 24V Direct Connect:

Internal / External	Terminal	Designation	Functional description
External	1	Power+	Power supply 24V d.c. ± 20%
External	2	Power-	Power supply 24V d.c. (GND)
Internal	3	O0 Digital Output	PLC input valve status / closed
Internal	4	O1 Digital Output	PLC input valve status / open
Internal	5	O2 Digital Output	PLC input valve status / upper seat lift
Internal	6	O3 Digital Output	PLC input valve status / lower seat lift
Internal	7	SV Digital Output	PLC input service request
Internal	8	I0 Digital Input	PLC output to activate solenoid 1 / main valve
Internal	9	I1 Digital Input	PLC output to activate solenoid 2 / upper seat lift
Internal	10	I2 Digital Input	PLC output to activate solenoid 3 / lower seat lift
Internal	11	+5VDC	Supply voltage for SPX prox. sensor / linear sensor
Internal	12	S	Signal SPX prox. sensor
Internal	13	0V	Potential for SPX prox. sensor / linear sensor
Internal	Linear sensor	Linear sensor	--
Internal	Y1	PWM Output	Solenoid valve 1 (main valve)
Internal	Y2	PWM Output	Solenoid valve 2 (upper seat lift)
Internal	Y3	PWM Output	Solenoid valve 3 (lower seat lift)
External	Service port	--	Connection serial/USB converter for CU4plus toolbox software

For the control unit type CU4*plus 24V IO-Link:

Internal / External	Terminal	Designation	Functional description
External	1	Power+	Operating voltage + (18 V...30 V d.c.)
External	2	Power-	Operating voltage – or Ground
Internal	3	C / Q	IO-Link Signal
Internal	4...10	--	Not in use
Internal	11	5 VDC	Voltage supply for valve sensor or extension module
Internal	12	Sensor 2	Sensor 2 connection or extension module
Internal	13	GND	Mass potential for sensor supply or extension module
Internal	JST	Sensor 1	Linear Sensor 1
Internal	14	Sensor 2	Sensor Signal 2
Internal	15	GND	Mass potential for sensor supply
Internal	Y1	PWM Output	Solenoid valve 1 (main valve)
Internal	Y2	PWM Output	Solenoid valve 2 (upper seat lift)
Internal	Y3	PWM Output	Solenoid valve 3 (lower seat lift)
External	Service port	--	Connection serial/USB converter for CU4plus toolbox software
Internal	P	Pressure sensor	Pressure measurement of main actuator

Page 4 of 5
Attachment to IECEx TUN 22.0020X issue No.: 0

For the control unit type CU4*24V Direct Connect:

Internal / External	Terminal	Designation	Functional description
External	1	Power+	Power supply 24V d.c. ± 20%
External	2	Power-	Power supply 24V d.c. (GND)
External	3	O0 Digital Output	PLC input valve status / closed
External	4	O1 Digital Output	PLC input valve status / open
External	5	SV Digital Output	Common
External	6	DI0 Digital Input	PLC output to activate solenoid 1 / main valve
External	7	DI1 Digital Input	PLC output to activate solenoid 2 / upper seat lift
External	8	DI2 Digital Input	PLC output to activate solenoid 3 / lower seat lift
External	9	DI common	Common signal
Internal	10	+5VDC	Supply voltage for SPX prox. sensor / linear sensor
Internal	11	Signal	Signal SPX prox. sensor
Internal	12	GND	Potential for SPX prox. sensor / linear sensor
Internal	13	+5VDC	Supply voltage for SPX prox. sensor / linear sensor
Internal	14	Signal	Signal SPX prox. sensor
Internal	15	GND	Potential for SPX prox. sensor / linear sensor

For the control unit type CU4*AS-interface:

Internal / External	Terminal	Designation	Functional description
External	1	AS-i +	Connection AS-i network (26.5 V...31.6 V d.c.)
External	2	AS-i -	Connection AS-i network (GND)
Internal	3	5 VDC	Voltage supply for proximity switches
Internal	4	Sensor 1	Signal sensor 1 (closed valve position)
Internal	5	GND	Common potential
Internal	6	5 VDC	Voltage supply for proximity switches
Internal	7	Sensor 2	Signal sensor 2 (open valve position)
Internal	8	GND	Common potential
Internal	10	Normal	Bridge for feedback signal
Internal	11	Feedback	Bridge for feedback signal
Internal	12	Reverse	Bridge for feedback signal

Page 5 of 5
Attachment to IECEx TUN 22.0020X issue No.: 0

Thermal data:

Control unit type CU4** resp. CU4*plus*:

Permissible ambient temperature range during operation: $0\text{ °C} \leq T_a \leq +55\text{ °C}$

Double seat valve type D4*:

The permissible ambient temperature range as process temperature (medium or cleaning solutions temperature) depending on the temperature class is shown in the following table:

Temperature of the medium or cleaning solution	Temperature class
0°C...80°C	T6
0°C...95°C	T5
0°C...130°C	T4

Assembly type D4*-CU4** / D4*-CU4*plus* 3G consisted of the control unit CU4** resp. CU4*plus* and the valve type D4*:

Control unit type CU4** resp. CU4*plus*:

Permissible ambient temperature range during operation: $0\text{ °C} \leq T_a \leq +55\text{ °C}$

Double seat valve type D4*:

The permissible ambient temperature range as process temperature (medium or cleaning solutions temperature) is $0\text{ °C} \leq T_a \leq +130\text{ °C}$

The reverse heat flow from the process beyond the permissible ambient temperature of the control unit CU4** resp. CU4*plus* is not possible by construction.

Specific Conditions of Use

- For the control unit type CU4** resp. CU4*plus* the permissible ambient temperature range during operation is $0\text{ °C} \leq T_a \leq +55\text{ °C}$
For the double seat valve type D4* the permissible ambient temperature range depending on the temperature class is the medium or cleaning solution's temperature and is to be taken from the operating instructions.
For the assembly type D4*-CU4** / D4*-CU4*plus* 3G the permissible ambient temperature range during operation at the control unit type CU4** resp. CU4*plus* is $0\text{ °C} \leq T_a \leq 55\text{ °C}$ and on the double seat valve type D4* is $0\text{ °C} \leq T_a \leq +130\text{ °C}$
- Metallic process connection parts of the double seat valve type D4* have to be included in the local potential equalization.
- The control unit CU4** resp. CU4*plus* and the plastic base of the double seat valve type D4* have to be installed and used in such a way, that electrostatic charging from operation, maintenance and cleaning is excluded.
- The base of the control unit CU4** resp. CU4*plus* has to be installed in such a way that it is protected from UV-radiation.
- The connecting and disconnecting of the pluggable electrical circuits inclusive the field wirings is only permitted if no explosive atmosphere exists.
- The control unit type CU4** resp. CU4*plus* has to be erected in such a way that a pollution degree 2 or better, according to IEC 60664-1, is achieved.
- Measures have to be taken, external to the control unit type CU4** resp. CU4*plus*, to provide a transient protection that ensures that the rated voltage, connected to the power supply terminals, is not exceeded by more than 40 %.
- To prevent the breaking of the springs, the actuator has to be replaced after 250,000 cycles.



CERTIFICATE FOR CHINA COMPULSORY PRODUCT CERTIFICATION

No.: 2023312304001783

Applicant SPX(Shanghai) Flow Technology Company Limited
Address No.666, Fengjin Road, Xidu Industry park, Fengxian District, Shanghai China
Manufacturer SPX Flow Technology Poland Sp. z o.o.
Address Stanisława Rolbieskiego 2, Bydgoszcz 85-862, Poland
Production Factory SPX Flow Technology Poland Sp. z o.o.
Production Address Stanisława Rolbieskiego 2, Bydgoszcz 85-862, Poland
Product Control unit
Model/Type CU4** , CU4*plus*
Ex marking Ex ec IIB T4 Gc
Reference Standards GB/T 3836.1-2021, GB/T 3836.3-2021

Certification mode Type Test + Initial Factory Inspection + Post-Certification Surveillance

The product(s) is verified and certified according to CNCA-C23-01: 2019 *China Compulsory Certification Implementation Rule on Explosion Protected Electrical Product* and CNEC-C2301-2019 *Guideline of China Compulsory Certification Implementation Rule on Explosion Protected Electrical Product*.

See Annex for the detailed product information (8 pages)

Initial issue date: 2023-10-27

Issued date: 2023-10-27

Valid to: 2028-10-26

The validity of this certificate is maintained through the regular supervision of the issuing authority during the validity period.

Where any discrepancy arises between the English translation and the original Chinese version, the Chinese version shall prevail.

Director:



Nanyang Explosion Protected Electrical Apparatus Research Institute Co.,Ltd.



<http://www.ccc-cnex.com>
ccc.china-ex.com

Add: No. 20, North Zhongjing Road, Nanyang, Henan, P. R. China P.C.: 473008
Tel: 0377-63239734 Email: ccc@cn-ex.com

CN0000078DZ



CERTIFICATE FOR CHINA COMPULSORY PRODUCT CERTIFICATION (Annex)

No.: 2023312304001783

Page 1 of 8

Product information:

1. This certificate covers the following models:

- CU4** , CU4*plus*

Nomenclature:

1) CU4**

CU4	*	*
	a	b

a:

- 1: 1 solenoid
- 2: 1 solenoid, 1NOT element
- 3: 3 solenoids

b:

- AS-interface
- 24V Direct Connect

2) CU4*plus*

CU4	*	plus	*
	a		b

a:

- 1: 1 solenoid
- 2: 1 solenoid, 1NOT element
- 3: 3 solenoids

b:

- AS-interface
- 24V Direct Connect
- 24V IO-Link

Electrical data:

Issued date: 2023-10-27

Director:



**Nanyang Explosion Protected Electrical
Apparatus Research Institute Co.,Ltd.**

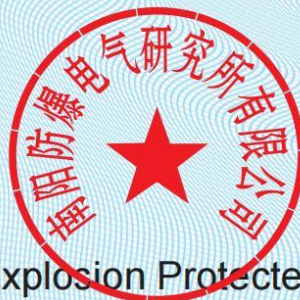



CERTIFICATE FOR CHINA COMPULSORY PRODUCT CERTIFICATION (Annex)

No.: 2023312304001783

Page 2 of 8

Control unit type CU4*AS-interface

Internal / External	Terminal	Designation	Functional description
External	1	AS-i +	Connection AS-i network (26.5 V...31.6 V d.c.)
External	2	AS-i -	Connection AS-i network (GND)
Internal	3	5 VDC	Voltage supply for proximity switches
Internal	4	Sensor 1	Signal sensor 1 (closed valve position)
Internal	5	GND	Common potenzial
Internal	6	5 VDC	Voltage supply for proximity switches
Internal	7	Sensor 2	Signal sensor 2 (open valve position)
Internal	8	GND	Common potenzial
Internal	10	Normal	Bridge for feedback signal
Internal	11	Feedback	Bridge for feedback signal
Internal	12	Reverse	Bridge for feedback signal

Control unit type CU4*24V Direct Connect:

Internal / External	Terminal	Designation	Functional description
External	1	Power+	Power supply 24V d.c. ± 20%
External	2	Power-	Power supply 24V d.c. (GND)
External	3	O0 Digital Output	PLC input valve status / closed
External	4	O1 Digital Output	PLC input valve status / open

Issued date: 2023-10-27

Director:



Nanyang Explosion Protected Electrical
Apparatus Research Institute Co.,Ltd.

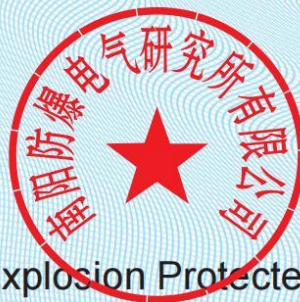



CERTIFICATE FOR CHINA COMPULSORY PRODUCT CERTIFICATION (Annex)

No.: 2023312304001783

Page 3 of 8

External	5	SV Digital Output	Common
External	6	DI0 Digital Input	PLC output to activate solenoid 1 / main valve
External	7	DI1 Digital Input	PLC output to activate solenoid 2 / upper seat lift
External	8	DI2 Digital Input	PLC output to activate solenoid 3 / lower seat lift
External	9	DI common	Common signal
Internal	10	+5VDC	Supply voltage for SPX prox. sensor / linear sensor
Internal	11	Signal	Signal SPX prox. sensor
Internal	12	GND	Potential for SPX prox. sensor / linear sensor
Internal	13	+5VDC	Supply voltage for SPX prox. sensor / linear sensor
Internal	14	Signal	Signal SPX prox. sensor
Internal	15	GND	Potential for SPX prox. sensor / linear sensor

Control unit type CU4* plus AS-interface

Internal / External	Terminal	Designation	Functional description
External	1	AS-i +	Connection AS-i network (26.5 V...31.6 V d.c.)
External	2	AS-i -	Connection AS-i network (GND)

Issued date: 2023-10-27

Director:

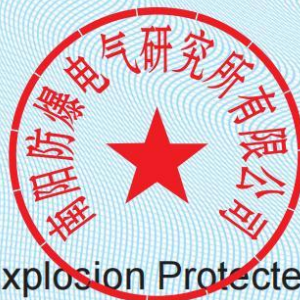

**Nanyang Explosion Protected Electrical
Apparatus Research Institute Co.,Ltd.**



<http://www.ccc-cnex.com>
ccc.china-ex.com

Add: No. 20, North Zhongjing Road, Nanyang, Henan, P. R. China P.C.: 473008
Tel: 0377-63239734 Email: ccc@cn-ex.com



CERTIFICATE FOR CHINA COMPULSORY PRODUCT CERTIFICATION

(Annex)

No.: 2023312304001783

Page 4 of 8

Internal	3	Z +	Bridge Z+ / PELV E+ (in case of energy supply for solenoid valves via AS-i bus)
Internal	4	Z -	Bridge Z- / PELV E - (in case of energy supply for solenoid valves via AS-i bus)
Internal	5	PELV E+	Separate auxiliary energy PELV 24VDC + (for EMERGENCY STOP function, only)
Internal	6	PELV E-	Separate auxiliary energy PELV 24VDC - (for EMERGENCY STOP function, only)
Internal	7	5 VDC	Voltage supply for proximity switches
Internal	8	Sensor 3	Signal sensor 3 (evaluation of logic table for appropriate valve type) for the control unit type CU4* AS-interface V1 resp. CU4* AS-interface V1 plus
		No sensor	For the control unit type CU4* AS-interface V2 resp. CU4* plus AS-interface V2
Internal	9	GND	Mass potential for sensor voltage supply
Internal	10	5 VDC	Voltage supply for proximity switches
Internal	11	Sensor 4	Signal sensor 4 (evaluation of logic table for appropriate valve type)
Internal	12	GND	Mass potential for sensor voltage supply
Internal	Linear sensor	Linear sensor	Linear sensor for valve position detection (for suitable SPX FLOW sensor, only!)
Internal	Y1	--	Solenoid valve 1 (main valve)
Internal	Y2	--	Solenoid valve 2 (upper seat lift)

Issued date: 2023-10-27

Director:

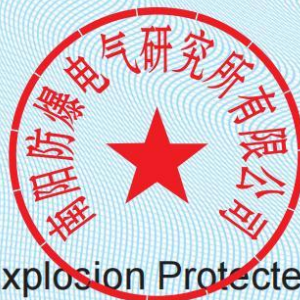

**Nanyang Explosion Protected Electrical
Apparatus Research Institute Co.,Ltd.**



<http://www.ccc-cnex.com>
ccc.china-ex.com

Add: No. 20, North Zhongjing Road, Nanyang, Henan, P. R. China P.C.: 473008
Tel: 0377-63239734 Email: ccc@cn-ex.com



CERTIFICATE FOR CHINA COMPULSORY PRODUCT CERTIFICATION (Annex)

No.: 2023312304001783

Page 5 of 8

Internal	Y3	--	Solenoid valve 3 (lower seat lift)
Internal	P	--	Optional connection - pressure sensor
External	Service port	--	Connection serial/USB converter for CU4plus toolbox software

Control unit type CU4* plus 24V Direct Connect

Internal / External	Terminal	Designation	Functional description
External	1	Power+	Power supply 24V d.c. ± 20%
External	2	Power-	Power supply 24V d.c. (GND)
Internal	3	O0 Digital Output	PLC input valve status / closed
Internal	4	O1 Digital Output	PLC input valve status / open
Internal	5	O2 Digital Output	PLC input valve status / upper seat lift
Internal	6	O3 Digital Output	PLC input valve status / lower seat lift
Internal	7	SV Digital Output	PLC input service request
Internal	8	I0 Digital Input	PLC output to activate solenoid 1 / main valve
Internal	9	I1 Digital Input	PLC output to activate solenoid 2 / upper seat lift
Internal	10	I2 Digital Input	PLC output to activate solenoid I2 / lower seat lift
Internal	11	+5VDC	Supply voltage for SPX prox. sensor / linear sensor

Issued date: 2023-10-27

Director:



**Nanyang Explosion Protected Electrical
Apparatus Research Institute Co.,Ltd.**



<http://www.ccc-cnex.com>
ccc.china-ex.com

Add: No. 20, North Zhongjing Road, Nanyang, Henan, P. R. China P.C.: 473008
Tel: 0377-63239734 Email: ccc@cn-ex.com



CERTIFICATE FOR CHINA COMPULSORY PRODUCT CERTIFICATION (Annex)

No.: 2023312304001783

Page 6 of 8

Internal	12	S	Signal SPX prox. sensor
Internal	13	0V	Potential for SPX prox. sensor / linear sensor
Internal	Linear sensor	--	--
Internal	Y1	PWM Output	Solenoid valve 1 (main valve)
Internal	Y2	PWM Output	Solenoid valve 2 (upper seat lift)
Internal	Y3	PWM Output	Solenoid valve 3 (lower seat lift)
External	Service port	--	Connection serial/USB converter for CU4plus toolbox software

Control unit type CU4*plus 24V IO-Link

Internal / External	Terminal	Designation	Functional description
External	1	Power+	Operating voltage + (18 V...30 V d.c.)
External	2	Power-	Operating voltage – or Ground
Internal	3	C /Q	IO-Link Signal
Internal	4...10	--	Not in use
Internal	11	5 VDC	Voltage supply for valve sensor or extension module
Internal	12	Sensor 2	Sensor 2 connection or extension module
Internal	13	GND	Mass potential for sensor supply or extension module

Issued date: 2023-10-27

Director:



**Nanyang Explosion Protected Electrical
Apparatus Research Institute Co.,Ltd.**



<http://www.ccc-cnex.com>
ccc.china-ex.com

Add: No. 20, North Zhongjing Road, Nanyang, Henan, P. R. China P.C.: 473008
Tel: 0377-63239734 Email: ccc@cn-ex.com



CERTIFICATE FOR CHINA COMPULSORY PRODUCT CERTIFICATION (Annex)

No.: 2023312304001783

Page 7 of 8

Internal	JST	Sensor 1	Linear Sensor 1
Internal	14	Sensor 2	Sensor Signal 2
Internal	15	GND	Mass potential for sensor supply
Internal	Y1	PWM Output	Solenoid valve 1 (main valve)
Internal	Y2	PWM Output	Solenoid valve 2 (upper seat lift)
Internal	Y3	PWM Output	Solenoid valve 3 (lower seat lift)
External	Service port	--	Connection serial/USB converter for CU4plus toolbox software
Internal	P	Pressure sensor	Pressure measurement of main actuator

Ex marking: Ex ec IIB T4 Gc

- Producers should organize production in accordance with the technical documents approved by the certification body.

2. Specific conditions of safety use:

- Ambient temperature range: 0°C~+55°C.
- The control unit CU4** resp. CU4*plus* have to be installed and used in such a way, that electrostatic charging from operation, maintenance and cleaning is excluded.
- The base of the control unit CU4** resp. CU4*plus* has to be installed in such a way that it is protected from UV-radiation.
- The connecting and disconnecting of the pluggable electrical circuits inclusive the field wirings is only permitted if no explosive atmosphere exists.
- The control unit type CU4** resp. CU4*plus* has to be erected in such a way that a pollution degree 2 or better, according to GB/T 16935.1, is achieved.

Issued date: 2023-10-27

Director:

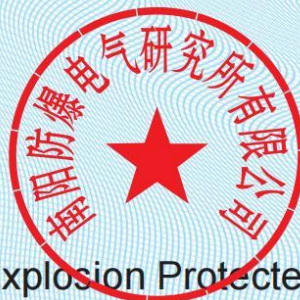

**Nanyang Explosion Protected Electrical
Apparatus Research Institute Co.,Ltd.**



<http://www.ccc-cnex.com>
ccc.china-ex.com

Add: No. 20, North Zhongjing Road, Nanyang, Henan, P. R. China P.C.: 473008
Tel: 0377-63239734 Email: ccc@cn-ex.com



CERTIFICATE FOR CHINA COMPULSORY PRODUCT CERTIFICATION (Annex)

No.: 2023312304001783

Page 8 of 8

- Measures have to be taken, external to the control unit type CU4** resp. CU4*plus*, to provide a transient protection that ensures that the rated voltage, connected to the power supply terminals, is not exceeded by more than 40%.

- See instruction for other information.

3. Certificate related report(s):

- Type test report: CQST2309C003

- Factory inspection report: CN2023Q010528

4. Certificate change information: None

Issued date: 2023-10-27

Director:



Nanyang Explosion Protected Electrical
Apparatus Research Institute Co.,Ltd.

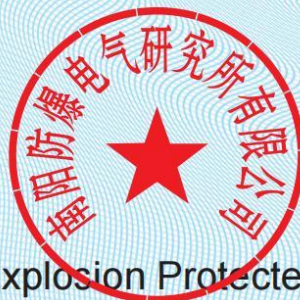

<http://www.ccc-cnex.com>
ccc.china-ex.com

Add: No. 20, North Zhongjing Road, Nanyang, Henan, P. R. China P.C.: 473008
Tel: 0377-63239734 Email: ccc@cn-ex.com

Information contained in this document is subject to change without notice and does not represent a commitment on the part of SPX FLOW, Inc.. No part of this document may be reproduced or transmitted in any form or by any means, electronic or mechanical, including photocopying and recording, for any purpose, without the express written permission of SPX FLOW, Inc..

Spare Parts list

CU4plus D4 IO-Link
3 G Ex ec IIB T4 Gc
IECEX - Zone 2



Date: 29.06.22
 Name: C.Keil
 Reviewed: C.Keil

SPX FLOW

Page 1 of 2

RN ATEX 01.044-8

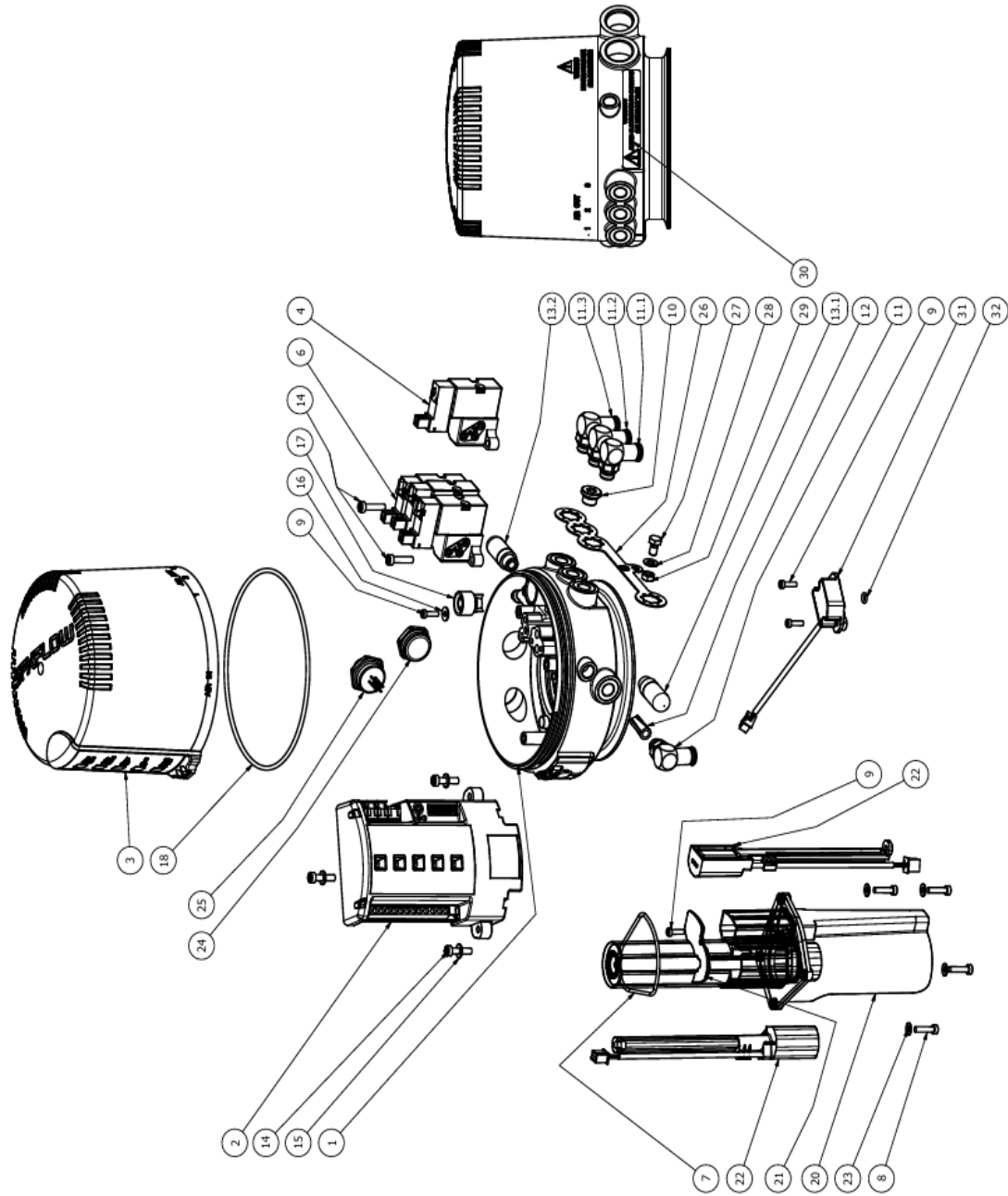

Information contained in this document is subject to change without notice and does not represent a commitment on the part of SPX FLOW, Inc.. No part of this document may be reproduced or transmitted in any form or by any means, electronic or mechanical, including photocopying and recording, for any purpose, without the express written permission of SPX FLOW, Inc..

Spare parts list

CU4plus D4 IO-Link II 3 G Ex ec IIB T4 Gc IECEx - Zone 2



Date: 29.06.23
 Name: C. Keil
 Reviewed:

SPX FLOW

Date: _____
 Name: _____
 Reviewed: _____

Page 2 of 2

RN ATEX 01.044-8

pos. item	Quantity	Description	required in version	Material	Part no.
		CU41plus D4 M12 IO-Link IECEx Z2		PA6.6 GF30	H348008
		CU43plus D4 M12 IO-Link IECEx Z2		PA6.6 GF30	H348004
1	1	CU41 Ex Base M cpl.	CU41	PA6.6 GF30 +PA12	H344231
1	1	CU43 Ex Base M cpl.	CU43	PA6.6 GF30 +PA12	H344232
2	1	CU4plus IO-Link E-Modul	CU41+43	Zyrel 70G33L black	H344393
3	1	CU4 cover translucent	CU41+43	Lexan 945AU	H337948
4	1	Solenoid valve 1 sol.	CU41	PPS	H319950
6	1	Solenoid valve 3 sol.	CU43	PPS	H319952
7	1	O-ring 45,6 x 2,4	CU41+43	NBR	H320401
8	4	Ejot Delta PT screw WN5452 35x14	CU41+43	A2	H320364
9	6	Ejot Delta PT screw WN5452 30x10	CU41+43	A2	H320363
10	1	IECEX blind plug CU4	CU41	Ms / nickel-plated	H347957
11	1	Elbow connector G1/8" 6x1	CU41+43	1.4301 / PA	H208825
11.1	1	Elbow connector G1/8" 6x1	CU41+43	1.4301 / PA	H208825
11.2	1	Elbow connector G1/8" 6x1	CU43	1.4301 / PA	H208825
11.3	1	Elbow connector G1/8" 6x1	CU43	1.4301 / PA	H208825
12	1	CU4 air filter	CU41+43	PE-porous	H320223
13.1	1	Sound reducer	CU41+43	PE-porous	H347802
13.2	1	Sound reducer	CU43	PE-porous	H347802
14	5	Ejot Delta PT screw WN5452 40x16	CU41+43	A2	H320365
15	3	Washer ø4,3 DIN125	CU41+43	A2	H79576
16	1	Washer A 3,2 DIN9021	CU41+43	A2	H320404
17	1	CU4 pressure relief valve	CU41+43	PPS	H320352
18	1	O-ring 120,32 x 2,62	CU41+43	NBR	H320402
20	1	CU4plus sensortower D4 V2	CU41+43	PET	H339461
21	1	Cap CU4plus sensor tower	CU41+43	Noryl 731 S	H339432
22	2	CU4plus Sensor V2	CU41+43	Noryl 731 S	H339463

pos. item	Quantity	Description	required in version	Material	Part no.
23	4	Washer A=3,7	CU41+43	A2	H323771
24	1	Blind cap V-Ex M20 x 1,5	CU41+43	PA	H347803
25	1	Female Flange M12x1,5 - 4pin	CU41+43	Ms / nickel-plated	H338108
26	1	CU4 equipotential bonding rail	CU41+43	1.4310	H347605
27	1	Hex. screw M5x8	CU41+43	A2	H339700
28	1	Washer l=5,3	CU41+43	A2	H79587
29	1	Hex. Nut M5	CU41+43	A2	H79276
30	1	ATEX CU label - Electrostatic risk	all versions	Tevus	H345151
31	1	CU4plus pressure sensor cpl.	CU41+43	PA6 GF 30	H336026
32	1	O-ring 4-1,5	CU41+43	NBR	H336024

CU4plus Adapter

Adapter spareparts information to be found in document: RN 01.044.3-1

Information contained in this document is subject to change without notice and does not represent a commitment on the part of SPX FLOW, Inc. No part of this document may be reproduced or transmitted in any form or by any means, electronic or mechanical, including photocopying and recording, for any purpose, without the express written permission of SPX FLOW, Inc.

Ersatzteilliste: spare parts list

CU4plus Adapter

SPX FLOW

Datum:	26.01.16	04.04.16	20.05.19	09.11.19
Name:	Trytko	Trytko	C.Keil	C.Keil
Geprüft:	Schulz	Schulz	C.Keil	C.Keil

Blatt 1 von 6

RN01.044.3-1

CU4Plus D4 Adapter

V1

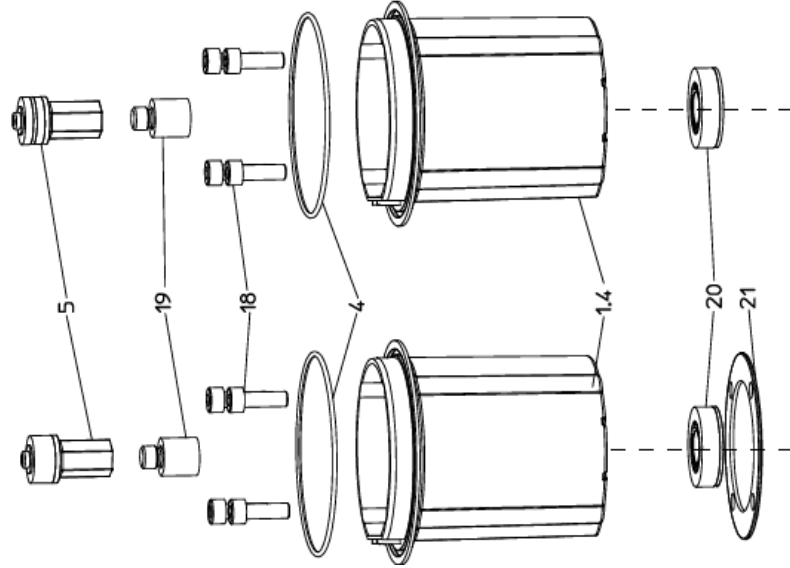

CU4Plus M - Adapter

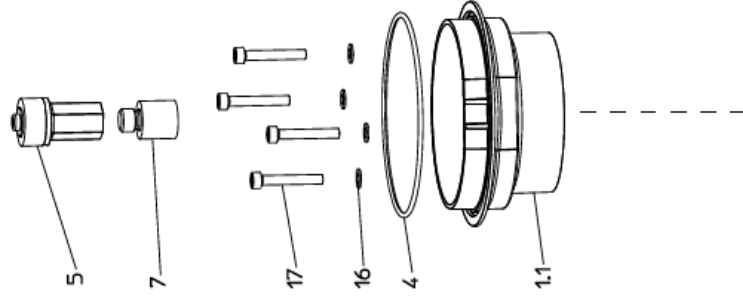

CU4Plus T - Adapter

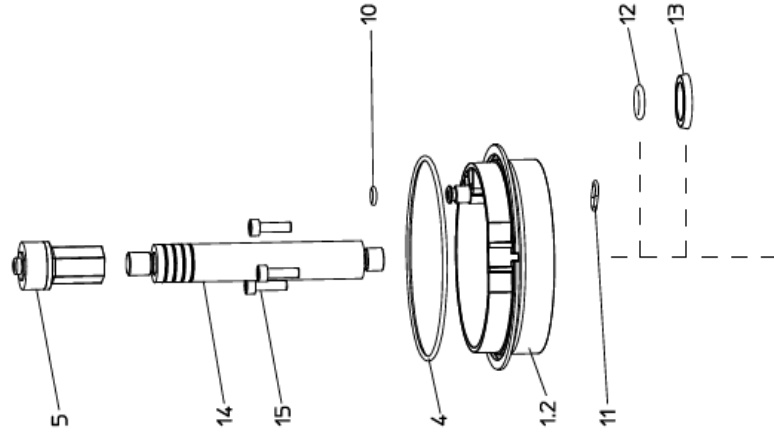

CU4Plus S - Adapter

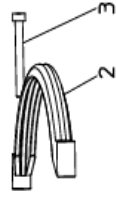
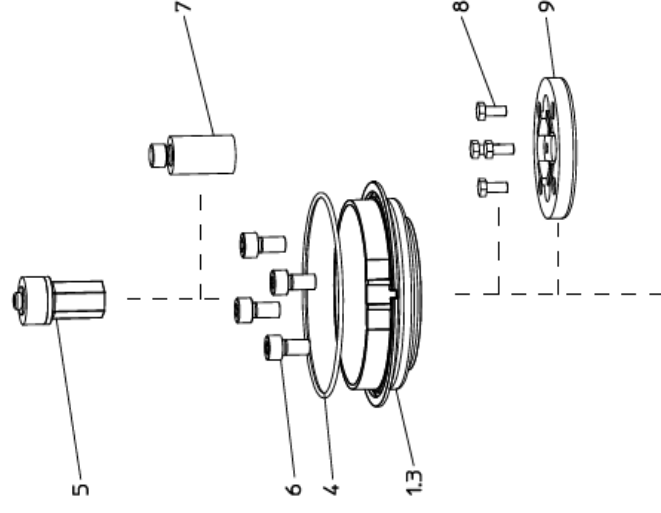

Information contained in this document is subject to change without notice and does not represent a commitment on the part of SPX FLOW, Inc. No part of this document may be reproduced or transmitted in any form or by any means, electronic or mechanical, including photocopying and recording, for any purpose, without the express written permission of SPX FLOW, Inc.

Ersatzteilliste: spare parts list

CU4plus Adapter

Datum:	26.01.16	04.04.16	20.05.19	09.11.19
Name:	Trytko	Trytko	C.Keil	C.Keil
Geprüft:	Schulz	Schulz	C.Keil	C.Keil
Datum:	26.01.21			
Name:	C.Keil			
Geprüft:	C.Keil			

SPX FLOW

Blatt 2 von 5

RN01.044.3-1

CU4plus DT4 -62 Adapter

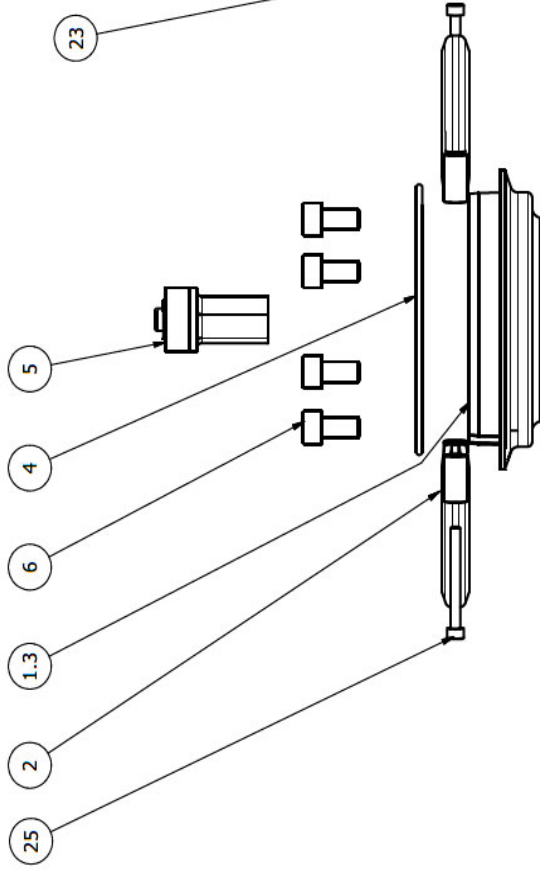

CU4plus DT4 -92 Adapter

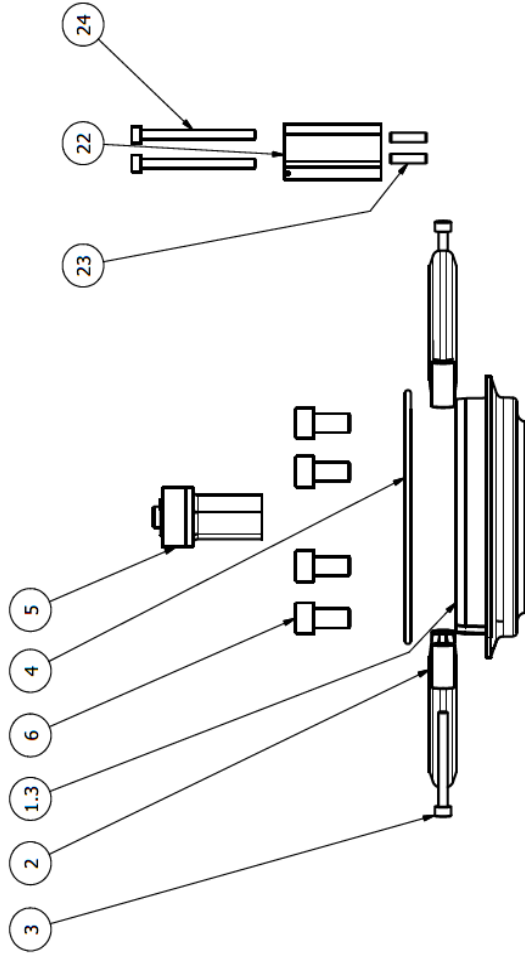

Information contained in this document is subject to change without notice and does not represent a commitment on the part of SPX FLOW, Inc. No part of this document may be reproduced or transmitted in any form or by any means, electronic or mechanical, including photocopying and recording, for any purpose, without the express written permission of SPX FLOW, Inc.

Ersatzteilliste: spare parts list

CU4plus Adapter

pos. item	Menge quantity	Beschreibung description	Material	CU4plus - S	CU4plus - S Langhub ø165	CU4plus-Smini	CU4plus-Smax	CU4plus - T	CU4plus-Tmax
				WS-Nr. ref.-no.	WS-Nr. ref.-no.	WS-Nr. ref.-no.	WS-Nr. ref.-no.	WS-Nr. ref.-no.	WS-Nr. ref.-no.
		CU4 Adapter kpl. CU4 adapter cpl.		08-48-690/93 H333143	08-48-696/93 H335312	08-48-691/93 H333144	08-48-692/93 H333145	08-48-693/93 H333146	08-48-694/93 H333147
1.1	1	CU4 Adapter M CU4 adapter M	Zytel 70G33L schwarz						
1.2	1	CU4 Adapter T CU4 adapter T	Zytel 70G33L schwarz					08-46-571/93 H319875	
1.3	1	CU4 Adapter S CU4 adapter S	Zytel 70G33L schwarz		08-46-570/93 H319874				
2	2	CU4 Clamphalbschale kpl. CU4 clamp cpl.	Grivory GH-5H1					08-46-569/93 H319873	
3	2	Zylinderschraube Cyl. Screw	A2-70					65-05-040/13 H320360	
4	1	O-Ring O-ring	NBR					58-06-493/83 H148389	
5	1	CU4 Magnetschaltnocke kpl. CU4 magnet switch cam cpl.	Zytel HTN					08-46-767/93 H333099	
6	4	Zylinderschraube Cyl. Screw	A2-70	65-05-120/13 M8x16 H79012	65-05-122/13 M8x25 H79014	65-05-120/13 M8x16 H79012	65-05-129/13 M8x60 H315760		
7	1	Zugstangenverlängerung Guide rod extension	PA6			15-26-070/93 H208096	15-26-058/93 H327149		
8	4	Skt. Schraube Hex. screw	A2-70			65-01-033/15 H78737			
9	1	CU Adapter SW4 CU adapter SW4	PA6		08-48-359/93 H330879	08-48-355/93 H207570	08-48-361/93 H327150		
10	1	O-Ring O-ring	NBR					58-06-059/83 H320505	
11	1	O-Ring O-ring	NBR					58-06-034/83 H321897	
12	1	O-Ring O-ring	NBR						58-06-039/83 H208632

SPX FLOW

Blatt 3 von 6

RN01.044.3-1

APV CU4*plus*
24V IO-Link
Control Unit

FOR IECEx ZONE 2 GAS APPLICATIONS

SPXFLOW[®]

SPX FLOW

Design Center / Manufacturer

Gottlieb-Daimler-Straße 13
D-59439 Holzwickede, Germany
P: (+49) (0) 2301-9186-0
F: (+49) (0) 2301-9186-300

SPX FLOW

Production

Stanisława Jana Rolbieskiego 2
PL- Bydgoszcz 85-862, Poland
P: (+48) 52 566 76 00
F: (+48) 52 525 99 09

SPX FLOW reserves the right to incorporate the latest design and material changes without notice or obligation.

Design features, materials of construction and dimensional data, as described in this manual, are provided for your information only and should not be relied upon unless confirmed in writing. Please contact your local sales representative for product availability in your region.

For more information visit www.spxflow.com.

ISSUED 06/2023 - Original Manual

COPYRIGHT ©2023 SPX FLOW, Inc.