



# SM & SG SERIES

## Top - Side - Bottom Entry Mixer

### Compact Mixer

The SM and SG series are compact agitators with direct drive mechanisms. The driver unit is available as an IEC motor or gearmotor. Optional configurations include hollow shaft motors and top, side or bottom entry orientations.

### Advantages

- Reliable performance even at low torque.
- Perfect concentricity and quiet operation at all speeds.
- Sealing technology range from radial shaft sealing with oil drip pan up to high tech hygienic double – acting mechanical sealing.
- Wide range of applications even for the standard unit and low cost system modifications through the use of great variety of alternate components.



#### SPECIFICATIONS AND TECHNICAL DATA

Motor Power	0,37 - 15 kW
Shaft Diameter	25 - 60 mm
Key Applications	<b>Aseptic, Beverage Processing:</b> Nutritional & Medical Drinkable Food, Soft Drinks, Plant-based Drinks, Wine & Spirits, <b>Dairy Processing:</b> ESL Milk, Ice Cream

## Orientations

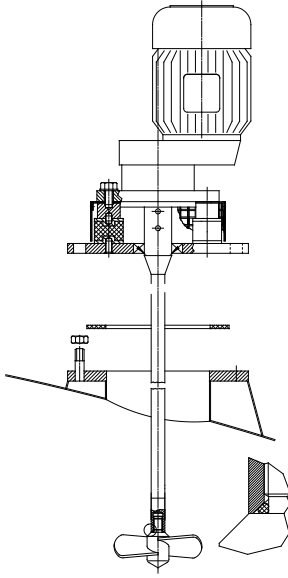

**SM/SG Top Entry**

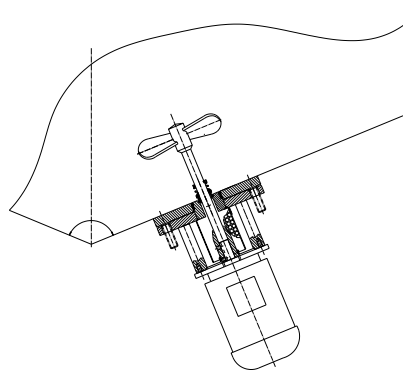

**SM/SG Bottom Entry**

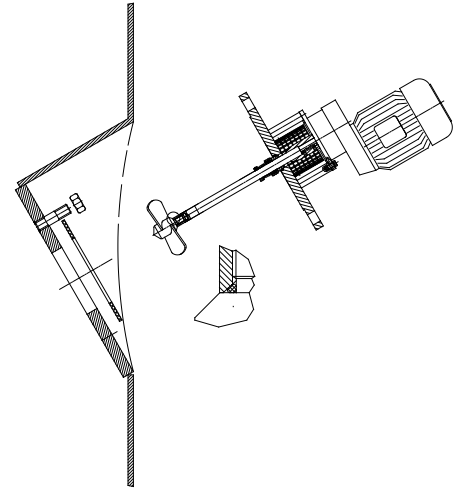

**SM/SG Side Entry**

## Applications

### Side Entry Mixing

SM/SG series side entry mixers are used to mix milk, wine, fruit juices and edible oils at low to medium viscosities. With optimized horizontal and vertical angling against the vessel wall, these mixers ensure thorough and uniform mixing throughout the entire tank, resulting in homogeneous blending.



### Bottom Entry Mixing

Bottom entry mixers from the SM/SG series are ideal for tall tanks. Through advanced computational fluid dynamics (CFD) flow simulation, the placement and design of these mixers at the tank's bottom ensure optimal performance.



# SPXFLOW®

SPX FLOW, Inc. reserves the right to incorporate our latest design and material changes without notice or obligation. Design features, materials of construction and dimensional data, as described in this bulletin, are provided for your information only and should not be relied upon unless confirmed in writing. Please contact your local sales representative for product availability in your region. The green "»" is a trademark of SPX FLOW, Inc.

For more information, visit [www.spxflow.com](http://www.spxflow.com).