

STONE[®]



AC and DC
Hydraulic Power Packs

SPX[®]

HYDRAULIC TECHNOLOGIES

www.stonehydraulics.com

Hydraulic DC Power Packs

Applications

- Aerial work platforms
- Tipper truck bodies
- Tail lifts
- Pallet trucks
- Paraplegic lifts
- Snow ploughs
- Tipping trailers

Features

- Wide range of DC motor options
- Industry standard cartridge valves
- Unique motor designs with balanced armatures
- Choice of voltages up to 3 kW
- Pump displacement from 0,8 to 8,0 cc/rev
- Large selection of oil reservoir configurations and capacities

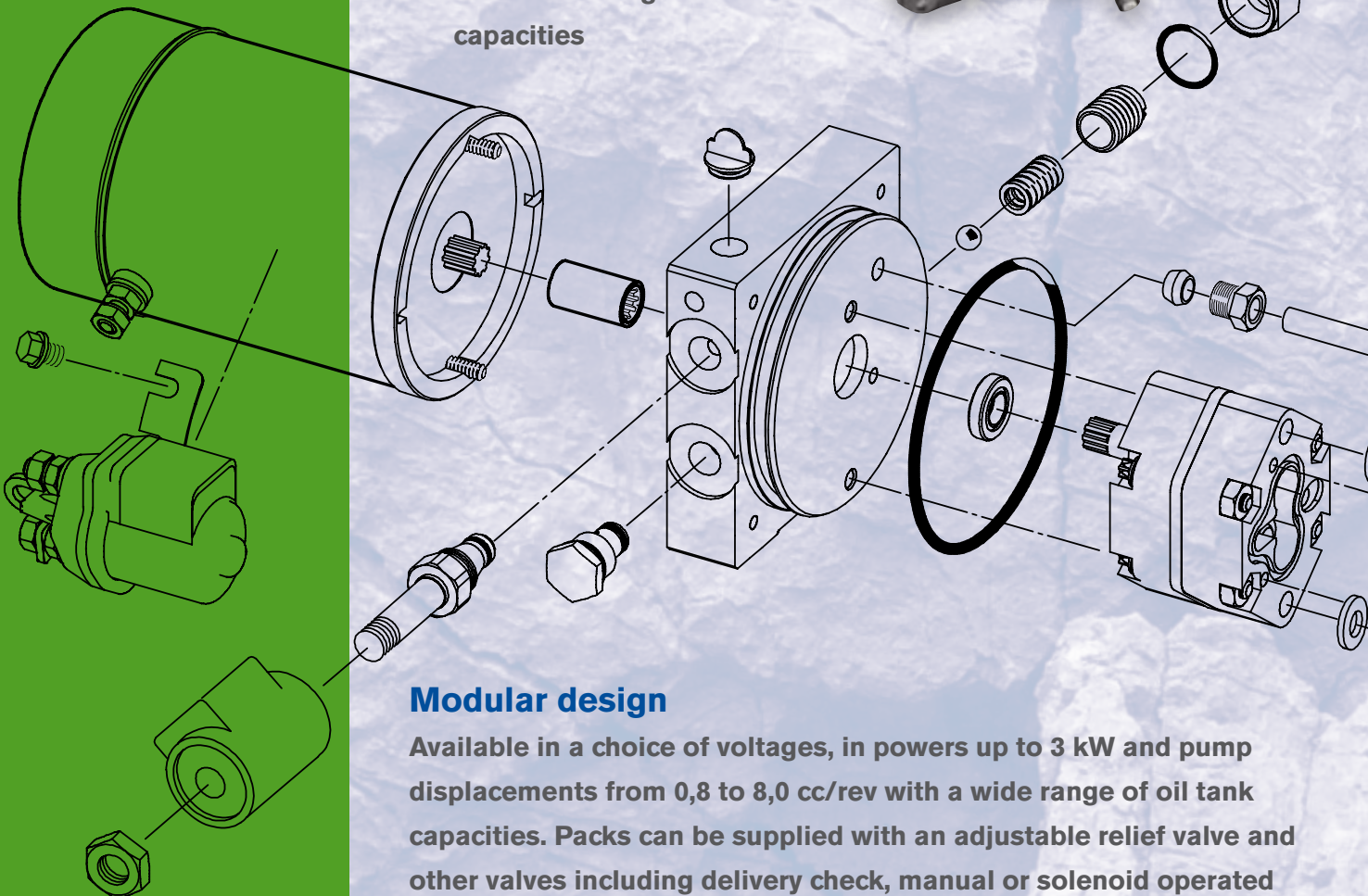
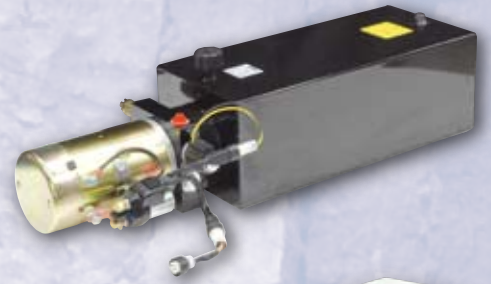

Modular design

Available in a choice of voltages, in powers up to 3 kW and pump displacements from 0,8 to 8,0 cc/rev with a wide range of oil tank capacities. Packs can be supplied with an adjustable relief valve and other valves including delivery check, manual or solenoid operated release are optional. CETOP valves are also available, together with custom manifold packages with built in valve options.

Hydraulic Micro Power Packs

For applications where the mounting space is limited and maximum performance and reliability are required, Stone Hydraulics developed hydraulic micro power packs.



Hydraulic AC Power Packs

Available in a wide range of powers up to 4,0 kW for single and three phase voltage supply with pump displacements of 0,8 to 8,0 cc/rev. Packs can be supplied with a large selection of oil reservoir configurations and capacities. Hydraulic power packs are supplied with an adjustable or fixed relief valve and other optional valves including delivery check and manual or solenoid operated release.

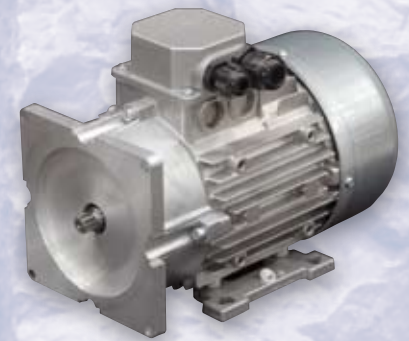

Applications

- Auto hoists
- Compactors
- Hose crimpers
- (Scissor) Lift tables

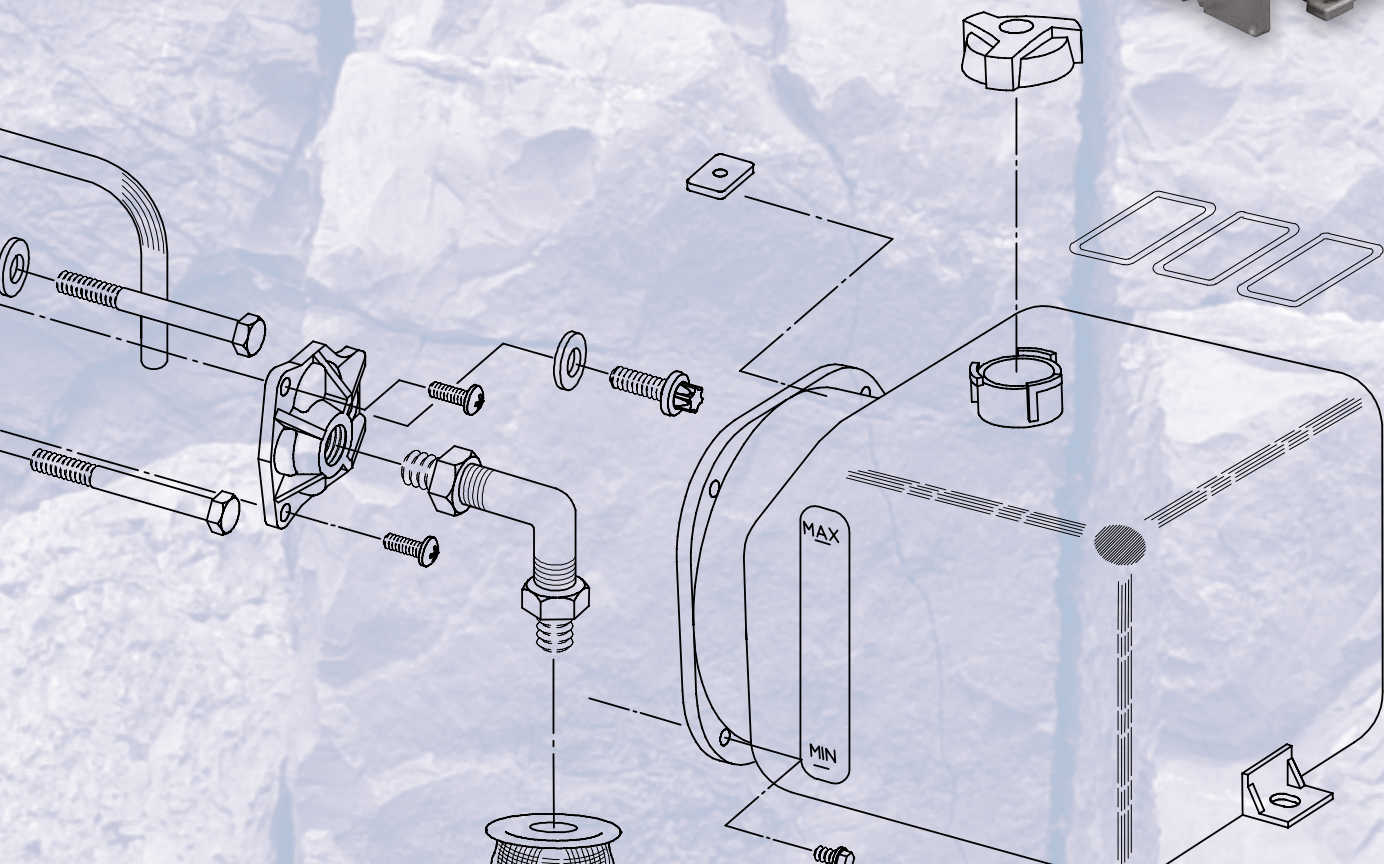

Accessories

Stone Power Packs can be fitted with a wide range of accessories, which can be adapted to the end-users needs and requirements.

Remote Controllers

Depending on the end-users requirements, Stone Hydraulics provides a customized remote controller that will be integrated with the power pack.

This enables safe and reliable operation of the power pack.

Pressure Alarm

The patented Stone Pressure alarm secures a safe working environment and the alarm sounds when the system is pressurized.

The alarm can be wired to operate all the time the system is pressurized or only in the up or down operations.



Applications

- Tipper truck bodies
- Tail lifts
- Paraplegic lifts
- Recreational vehicles
- Snow ploughs



Features

- Can be fitted on all power packs
- Durable and robust design
- Alarm sounds intermitantly

SPX®

HYDRAULIC TECHNOLOGIES

EUROPEAN CUSTOMER SERVICE CENTER

Albert Thijsstraat 12
6471 WX Eyselshoven, The Netherlands
Tel: 31 45 567 88 77
Fax: 31 45 567 88 78
Email: infoeurope@stonehydraulics.com

280 rue Henry Bessemer
60100 Creil, France
Tel. 33 3 44259975
Fax. 33 3 44640701
Email: infoeurope@stonehydraulics.com

Asia Pacific Customer Service Center

7 Gul Circle
Singapore 629563, Singapore
Tel: 65 6265 3343
Fax: 65 6265 6646
Email: infoasia@stonehydraulics.com

Americas Customer Service Center

American Customer Service Center
5885 11th Street
Rockford, Illinois 61109, United States
Tel: 1 800 8745556
Fax: 1 800 2887031
Email: info@stonehydraulics.com

China Customer Service Center

No. 1568 Hua Shan Road
International Park Center, Floor 9th
Shanghai, 200052, China
Tel: 86-21 2208-5888
Fax: 86-21 2208-5682
Email: infochina@stonehydraulics.com