

## WR60/WR80 Series

OVER-PRESSURE RELIEF VALVES



Protect your pump with an external over-pressure relief valve. If pump discharge pressure exceeds the set cracking-pressure, the valve will open to a relief path.

The adjustable-spring actuator allows users to set the desired relief cracking pressure right at the valve by simply turning the adjustment screw. The relief pressure setting can be bypassed to completely open the valve for CIP cleaning without over-pressuring the valve and pipeline.

SPX FLOW, Inc. (NYSE:FLOW) is a leading manufacturer of innovative flow technologies, many of which help define the industry standard in the market segments they serve. From its headquarters in Charlotte, North Carolina, it operates a sales and support network, centers of manufacturing excellence, and advanced engineering facilities, throughout the world. Its cutting-edge flow components and process equipment portfolio includes a wide range of pumps, valves, heat exchangers, mixers, homogenizers, separators, filters, UHT, and drying technology that meet many application needs. Its expert engineering capability also makes it a premium supplier of customized solutions and complete, turn-key packages to meet the most exacting of installation demands.

Incorporating many leading brands, SPX FLOW has a long history of serving the food and beverage, power and energy, and industrial market sectors. Its designs and engineered solutions help customers drive efficiency and productivity, increase quality and reliability, and meet the latest regulatory demands. In-depth understanding of applications and processes, state-of-the-art Innovation Centers, and advanced pilot/testing technology further assist in optimizing processes and reducing timescales to reliably meet production targets.

To learn more about SPX FLOW capabilities, its latest technology innovations and complete service offerings, please visit [www.spxflow.com](http://www.spxflow.com).

# Over-Pressure Relief Valves

## FEATURES AND BENEFITS

- Utilizes standard W60/W80 single seat components offering machined-from-bar bodies, modular design, Tef-Flow™ P stems, and low cost of ownership.
- Adjustable-spring, maintenance-free actuator allows easy setting of desired relief cracking pressure.
- Actuator piston bypasses relief pressure setting and fully opens valve for CIP cleaning without need to over-pressurize the valve and pipeline.
- Multiple body styles provide minimal dead-leg relief configurations with pump for efficient cleaning and processing.
- Various controls options available on valve for feedback and automation.
- W80 stem flush adapter available for aseptic applications.

## MATERIALS

Product Wetted: ASTM 316L (UNS-S31603); (DIN-1.4404)

Non-Product: ASTM 304 (UNS-S30400); (DIN-1.4301)

Seat Material: Tef-Flow™ P (Std.) and metal (Optional) for strength and durability

Elastomers: FKM or EPDM

Finish: ≤ 32Ra (≤0.8 μm) Other finishes available upon request

Sizes: Available in three actuator diameters, 4" (102mm), 5" (127mm) and 6" (152mm) with heavy springs for these series and sizes:  
 - WR61 air-to-raise valves (AR) 1.5" (38mm) – 4" (102mm)  
 - WR63 air-to-lower (AL) 2" (51mm) -4" (102mm)

## PRESSURE RATINGS

### Standard

VALVE SIZE WITH PRESSURE AT	1.0"/1.5" (25/38mm)	2.0" (51mm)	2.5" (64mm)	3.0" (76mm)	4.0" (101mm)	6.0"* (152mm)
70°F (20°C)	500 psi (34.5 bar)	450 psi (31 bar)	400 psi (28 bar)	350 psi (24 bar)	200 psi (14 bar)	150 psi (10 bar)
160/180°F (71/82°C)	375 psi (26 bar)	350 psi (24 bar)	300 psi (17 bar)	250 psi (17 bar)	150 psi (10 bar)	100 psi (6 bar)
250°F (121°C)	250 psi (17 bar)	250 psi (17 bar)	200 psi (14 bar)	150 psi (10 bar)	125 psi (8 bar)	75 psi (5 bar)

### Valve with High Pressure Adapter and Clamps

VALVE SIZE WITH PRESSURE AT	1.0"/1.5" (25/38mm)	2.0" (51mm)	2.5" (64mm)	3.0" (76mm)	4.0" (101mm)	6.0"* (152mm)
70°F (20°C)	1220 psi (84 bar)	900 psi (62 bar)	720 psi (49 bar)	--	--	--
160/180°F (71/82°C)	1160 psi (80 bar)	855 psi (60 bar)	690 psi (47 bar)	--	--	--
250°F (121°C)	1100 psi (75 bar)	830 psi (57 bar)	660 psi (45 bar)	--	--	--

3, 4 or 6 inch high pressure clamp not available.

\*6" valves available in W61 Shutoff and W65 Divert only. For other valve types contact factory.

For all valve options see Valve Key Datasheet (VK-1000)

# Typical product applications

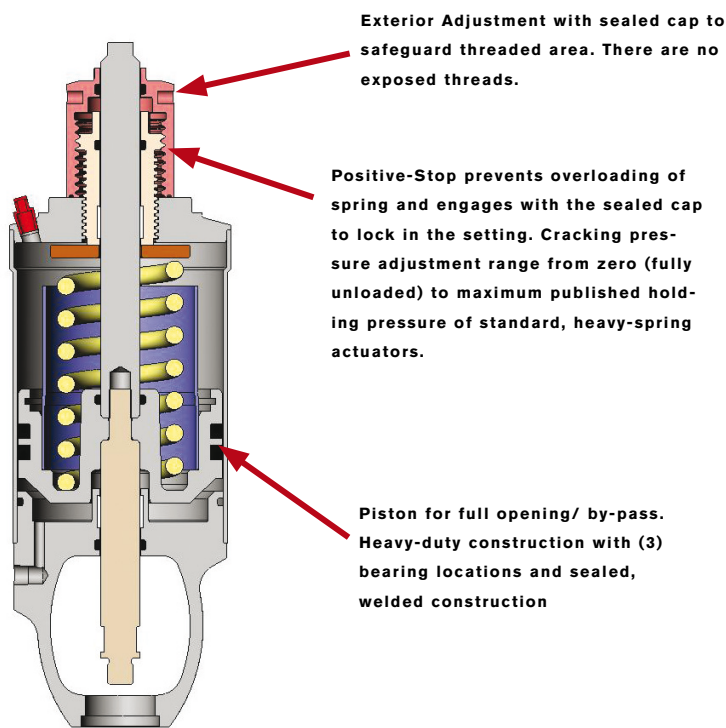

**NOTES:**

- Pump Over-Pressure valves are designated as WR60 and WR80 Series Valves.
- Not an ASME rated device or SRV. Not suitable for tanks or other pressure-vessels.
- WR60/WR80 valves are not factory-set to a specific cracking pressure. Once installed, the valve should be adjusted and calibrated to desired relief pressure and verified by a line pressure gauge.

**Beverage**

- Beer
- Cider
- Fruit Drinks
- Liquid Sugar and Glucose
- Soft Drinks
- Wine
- Wort



**Food**

- Animal Oils
- Flavorings
- Pet Food
- Soups and Sauces
- Vegetable Juices
- Vegetable Oils
- Vinegars



**Dairy**

- Cream
- Milk
- Milk Concentrate
- Raw Milk
- Skimmed Milk
- Whey
- Whey Concentrate



**Pharmaceutical and Toiletries**

- Emulsions
- Extracts
- Lotions
- Perfumes
- WFI (Water for Injection)
- High Purity Water
- Pure Water





**Chemical**

- Additives
- Adhesives
- Coatings
- Contaminated Liquids
- Detergents
- Emulsions
- Paint

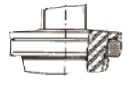

## OPTIONS AND ACCESSORIES

### SEAT OPTIONS

SEAT TYPE	MAXIMUM TEMPERATURE	APPLICATION	SERIES
	280°F (137°C)	High Temp High Pressure Pressure Relief	WR60 WR80
	375°F (190°C)	High Pressure High Flow Large Particulate	WR60 WR80

### PORT OPTIONS

- W = Weld
- S = S-Line
- I = I-Line (female - 15l)
- 14I = I-Line (male - 14l)
- B = Bevel Seat (male threaded end)
- F = Flange
- Q = Q-Line
- D = DIN 11851 405 Thread
- A = Aseptic I-Line (15NI)

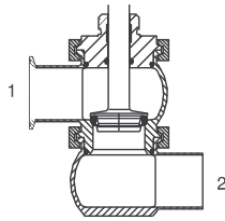

**Example:**  
**W61-TS-SW**

For mixed connection types, specify in order of port #.

### ADAPTER OPTIONS

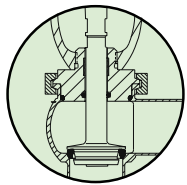

The 'standard' adaptor is used on all models of short and long stroke W60 Series valves. Machined from SS 316L bar with a thick cross-section, the adaptor adds strength to the valve body and provides alignment for the stem. The outer perimeter seals to the valve body with an o-ring that is located forward to the product zone to minimize crevices. The product stem passes through the adaptor and is sealed to the adaptor with an o-ring. A Teflon® bearing guides the stem and takes up the mechanical loading imparted by hydraulic forces. This increases the service life of the stem seal. Adaptors are made in 1"-6" (25mm -152mm) sizes.

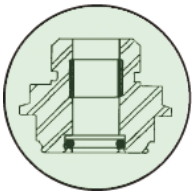

The pressure limitation of the W60 adaptor is the sealing capability of the dynamic o-ring on the product stem. This variation of the W60 adaptor uses a backing ring added on the atmospheric side to support the stem o-ring. This significantly boosts the pressure rating on the stem o-ring. The product stem passes through the adaptor and is sealed to the adaptor with an o-ring and is guided by a Teflon® bearing.

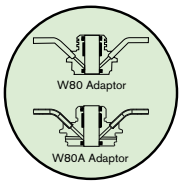

This adaptor is used to convert a 'standard' W60 series valve to a W80. The outer perimeter seals to the valve body with an o-ring that is located forward to the product zone to minimize crevices. The product stem passes through the adaptor and is sealed in the upper part and the lower part of the adaptor with o-rings. The space between the o-rings is flushed with a suitable liquid or steam. The Teflon® bearing is located in the flushed chamber. Adaptors are made in 1"-6" (25mm - 152mm) sizes. For vacuum-rated, extended shelf-life (ESL) applications, the W80A adaptor adds steam trace to the adapter-to-valve body connection

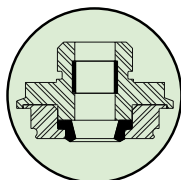

For high-risk and hard to clean product applications, the wiping stem seal fills the gap between the product zone and the traditional o-ring stem seal. The adaptor is a two-piece design to allow easy inspection or replacement of the wiping stem seal. The outer perimeter seals to the valve body with an o-ring that is located forward to the product zone to minimize crevices. A Teflon® bearing is used to guide and support the valve stem.

# Control Tops - WR63/WR83 Only

## WAUKESHA CHERRY-BURRELL CONTROL TOP



### Features And Benefits

- Transparent Control Top keeps all electrical components visible.
- Maintainable, designed with the user in mind, making assembly and troubleshooting worry free and easy.
- Waukesha Cherry-Burrell uses the industry's most widely recognized electrical components, so access to off the shelf replacement parts is easy, ensuring quick delivery and less down time.
- NEMA 4x (IP64)
- Stainless Steel Control Top Option



### Connector Options

- S/O Cord Grip for hard wire (std)
- Quick Disconnect Pin Connectors

### Interface Options

- AS-i Field Bus Card
- DeviceNet™ Field Bus Network Card

### Position Indication

- Set & Forget Switch
- Inductive Proximity Switches 20-140V AC/DC, 2-Wire (Std)
- Microswitches 24VDC, 110VAC
- Intrinsically safe options 5-24VDC



### Solenoid Valves

- 24VDC or 110VAC
- Select from 0 to 3 Solenoids

## CU4 CONTROL TOP



### Features And Benefits

- Reliability and long service life - robust clamp connection, reinforced Stainless Steel air coupling threads to avoid air leakages, and water tight seals
- Cost-effective - simple design and limited options for basic control top functionality
- Ease of operation - contains manual override solenoids and adjustment screw to throttle air flow to actuator to ensure optimal opening and closing
- Clarity - clear and bright indication of valve position - 5 diodes in LED panel and convenient location
- NEMA 6 (I67)

### Connector Options

- S/O Cord Grip for hard wire (std)
- Quick Disconnect Pin Connectors

### Interface Options

- AS-i Field Bus Card

### Position Indication

- 2 internal feedback sensor switches for valve open/ valve closed position detection

### Solenoid Valves

- 24V DC or 110V AC
- Select 1 solenoid or solenoid with NOT element (air/air or air assist)



## 8681 CONTROL TOP



### Features And Benefits

- Contact free position sensor including (3) programmable feedback signals
- Positions easily taught via intuitive push buttons or Autotune feature to ensure quick & easy set-up
- Ultra-bright 360° visual LED position indication with adjustable red, yellow, & green color assignments provide clarity from all points of view and avoid confusion
- Manual override and air throttle adjustable solenoids to assist start-up, maintenance, and troubleshooting
- Up to IP69K washdown rating available (IP65/67 as standard) for high washdown environments
- Built-in microcontroller tracks cycles and alerts operator when preventive maintenance is required
- Supplied by industry leading Burkert Fluid Controls

### Connector Options

- S/O Cord Grip for hard wire (STD)
- Quick Disconnect Pin Connectors

### Interface Options

- AS-i Field Bus Card
- DeviceNet™ Field Bus Network Card

### Position Indication

- (3) programmable position sensors in control top

### Solenoid Valves

- 24V DC or 110V AC
- Manual override and air throttle adjustment
- Up to (3) available in control top

## WR61/WR81 ONLY

- Yoke mount proximity switch
- (1) or (2) inductive proximity switches, 24VDC/110VAC 2-wire
- Intrinsically safe options
- Externally Mounted Solenoids

## CONFIGURATIONS AND THEORY OF OPERATION

### Over-Pressure Protection on a Positive-Displacement Pump using the Adjustable-Spring Actuator

#### Capacity Example:

- Model 30 Universal PD
- 1.5" (38 mm) Ports, 25 gpm (6 M<sup>3</sup>/hr)
- Cracking Pressure: 100 psi (7 bar)
- Air-to-Raise Configuration

Use the W61 Holding Pressure Charts in datasheet DS-1201 to select a maximum holding-pressure higher than the desired cracking pressure for a given plug size. Use the heavy-duty actuator listings i.e. 4RHAR. WR61 holding pressures also listed on page 10.

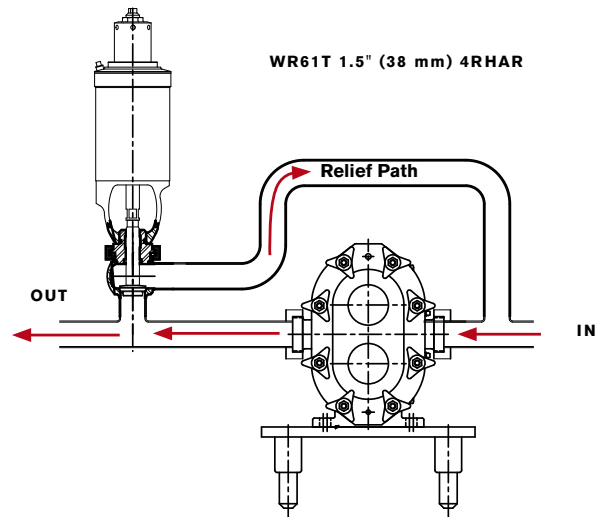

#### W61 AR/HAR (air-to-raise) - Standard Stroke

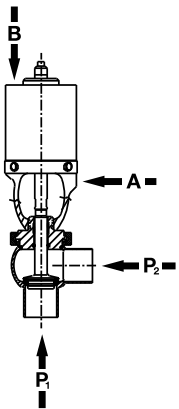

	VALVE SIZE - INCHES (MM) - PRESSURE IN PSI (BAR)						
	ACTUATOR SIZE IN (mm)	1" (25)	1.5" (38)	2" (51)	2.5" (64)	3" (76)	4" (102)
BOTTOM PORT (P <sub>1</sub> ), ACTUATOR SPRING HOLDS CLOSED AGAINST:	4RHAR	213 (15)	177 (12)	99 (7)	64 (4)	44 (3)	25 (2)
	5RHAR	---	378 (26)	212 (15)	136 (9)	94 (6)	54 (4)
	6RHAR	---	602 (42)	338 (23)	216 (15)	150 (10)	87 (6)

Select:

**4RHAR, maximum holding pressure of 177 psi (12 bar)**

The 4RHAR Adjustable-Spring actuator will also hold to 177 psi (12 bar) max when fully loaded.

Designate the W61 as a WR61.

## SELECTION: WR61T 1.5" 4RHAR

### Set Pressure

- Use tables on page 10 or in the W60/W80 Operation and Maintenance manual, 95-03022, to estimate the number of turns off the maximum to achieve the desired relief cracking pressure.
- 177 psi (12 bar) – 100 psi (7 bar) desired cracking point = 77 psi (5 bar)  
1.5" (38 mm) Plug, 4RHAR, 24 psi (2 bar) per turn reduction from maximum
- Turn adjustment screw 100% down (fully loaded to maximum), then back off 77/24 or approximately 3.2 turns to achieve 100 psi (7 bar) cracking pressure

Refer to page 9, Pressure Rise Charts for performance under flow.

### Air-To-Raise Spring-Adjustable Actuator Spring Setting Pressure change per turn of adjusting screw

PLUG SIZE	ACTUATOR		
	4RHAR	5RHAR	6RHAR
1.5	24	40	82
2.0	13	23	46
2.5	9	15	29
3.0	6	10	20
4.0	3	6	12

Screw may be different due to spring variations.

## CONFIGURATIONS AND THEORY OF OPERATION

### Over-Pressure Protection on a Positive-Displacement Pump using the Adjustable-Spring Actuator

For Free-draining, minimal dead-leg relief piping, use the WR63 valve, CD body and an Air-to-Lower, adjustable-spring actuator. If pump discharge pressure exceeds the set cracking-pressure, the valve will open and relieve the over-pressure to pump suction.

### SELECTION: WR63CD REVERSE-ACTING

WR63 Reverse-Acting Over-Pressure Relief with CD body for Cross-Flow Operation

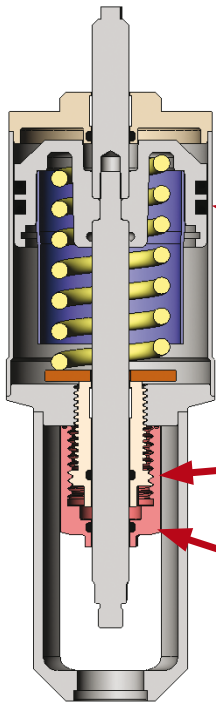
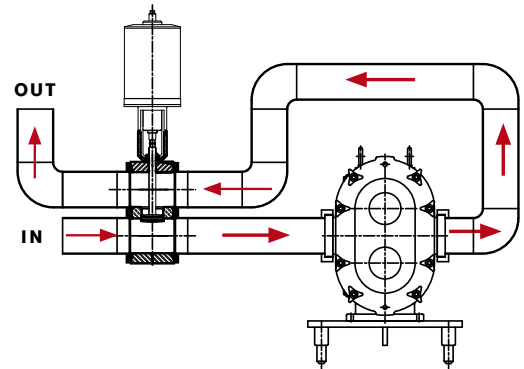

Cracking pressure adjustment range from zero (fully unloaded) to maximum published hold pressure of standard, heavy-spring actuators.

**Piston for full opening/by-pass. Heavy-Duty construction with (3) bearing locations and sealed, welded construction.**

**Positive-Stop prevents overloading of spring and engages with the sealed cap to lock in the setting.**

**Exterior Adjustment with sealed cap to safeguard threaded area.**

### SELECTION: WR61C AIR-TO-RAISE ADJUSTABLE-SPRING ACTUATOR

Air-to-Raise (WR61), Cross-Flow Body configurations also available for minimal dead-leg relief lines. Use the C, CM or CPS body with a close-coupled tee as a cost effective solution.

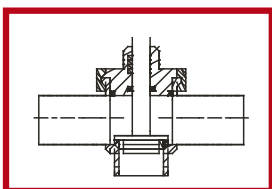
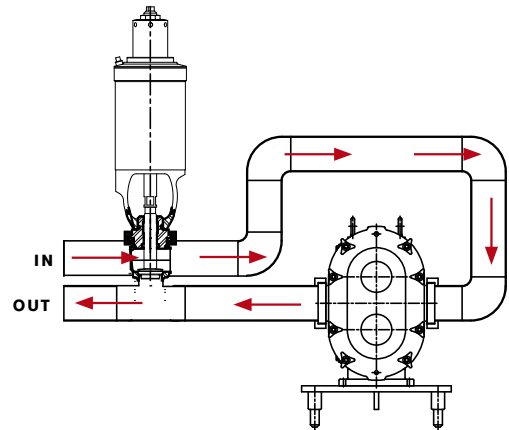

CM

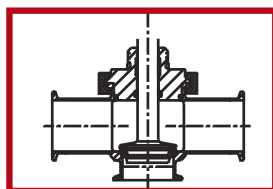

CPS

## CONFIGURATIONS AND THEORY OF OPERATION

### Over-Pressure Protection using a Reduced-Seat Valve and the Adjustable-Spring Actuator

Reduced-Seat Valve Bodies

#### Capacity Example:

- Model 220 Universal PD
- 4" (102 mm) Ports, 115 gpm (26m<sup>3</sup>/hr)
- Cracking Point: 170 psi (12 bar)
- Cross-flow, minimal dead-leg
- Air-to-lower (AL) configuration

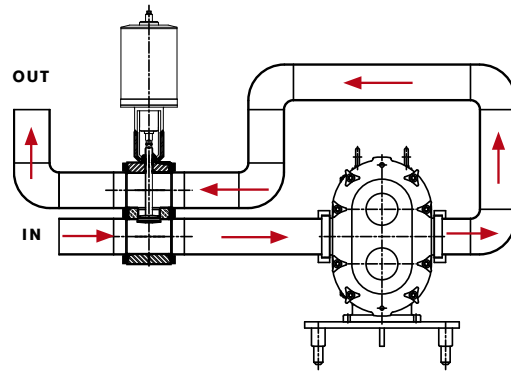

Use the W63 Holding Pressure Charts in datasheet DS-1201 to select a maximum holding-pressure higher than the desired cracking pressure for a given plug size. Use the heavy-duty actuator listings i.e. 4HAR. WR63 holding pressures also listed on page 10.

#### W63 AL/AHL (Air-to-Lower) - Standard Stroke

	VALVE SIZE - INCHES (MM) - PRESSURE IN PSI (BAR)				
	ACTUATOR SIZE IN (mm)	2" (51)	2.5" (64)	3" (76)	4" (102)
PORT (P <sub>1</sub> ), ACTUATOR SPRING HOLDS CLOSED AGAINST:	4HAL <sub>1</sub>	114 (8)	69 (5)	46 (3)	24 (2)
	5HAL <sub>1</sub>	244 (17)	147 (10)	99 (7)	52 (4)
	6HAL <sub>1</sub>	323 (22)	195 (13)	131 (9)	68 (5)

A cracking pressure of 170 psi (12 bar) is achievable - with a 2.5" (64 mm) plug

6HAL provides 68 psi (5 bar) max. holding pressure on a 4" (102 mm) plug- not enough to achieve desired cracking pressure of 170 psi (12 bar) for the chosen line size.

Selection:

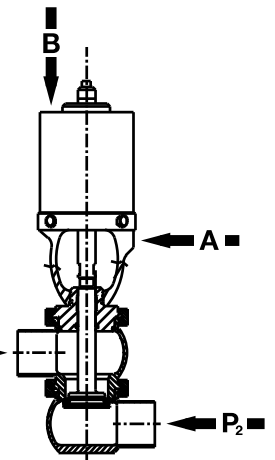

#### Reduced-Seat Selection: WR63CD 40/25 with the 6RHAL actuator

While the port connections and body remain 4.0" (102 mm), the valve plug is 2.5" (64 mm). The maximum holding pressure of the 2.5" (64 mm) plug can be used = 195 psi (13 bar).

For Reduced-Seat valves, pressure drop, pressure rise and reseating pressure must be estimated using the 2.5" (64 mm) valve plug size. Refer to Pressure Rise Charts on page 9.

When the desired cracking pressure exceeds the maximum holding pressure of the actuator- for the chosen valve size:

1. Consider reducing the valve size and using a reducer in the piping. This is the most cost-effect solution for T-body styles
2. For cross-flow bodies, a reduced-seat option can be selected.

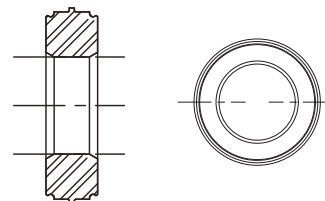

Reduced-Seat Insert 4.0/2.5



## ADDITIONAL TECHNICAL DATA

### WR61/WR63 Over-Pressure Valve Pressure Rise

Utilizing either Air-to-Rise or Air-to-Lower adjustable-spring actuators respectively

4" (102 mm)  
Diameter  
Actuator

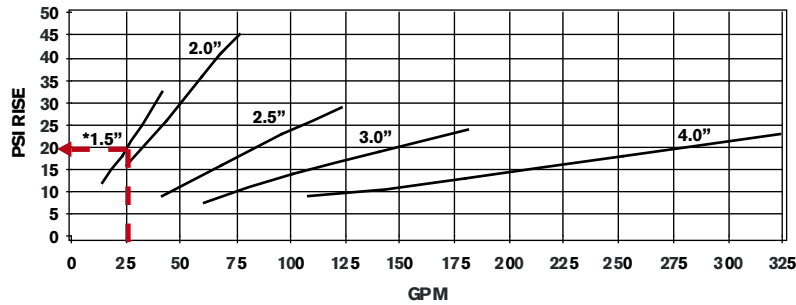

#### WR61T 1.5" (38) 4RHAR Actuator

Relief @ 25 gpm (6 m<sup>3</sup>/hr) will produce 20 psi (1 bar) added pressure rise.

(See notes below)

#### Reseating Pressure:

Total relief line pressure must drop by 20 psi (1 bar) for reseating.

(See notes below)

5" (127 mm)  
Diameter  
Actuator

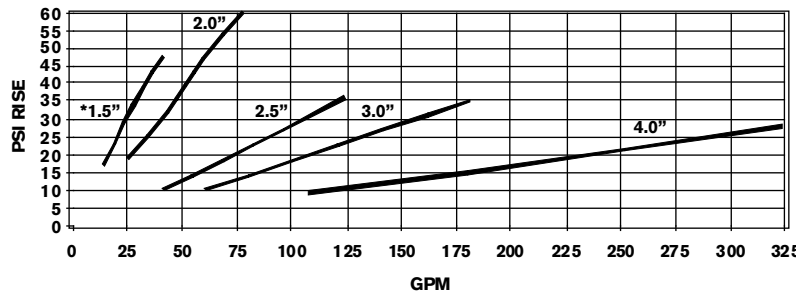

#### WR63CD 4.0"(102mm)/ 2.5" (64 mm) 6RHAL Actuator

Relief @ 115 gpm (26 m<sup>3</sup>/hr) adds 45 psi (3 bar) pressure rise with the 2.5" (64 mm) plug.

(See notes below)

6" (152 mm)  
Diameter  
Actuator

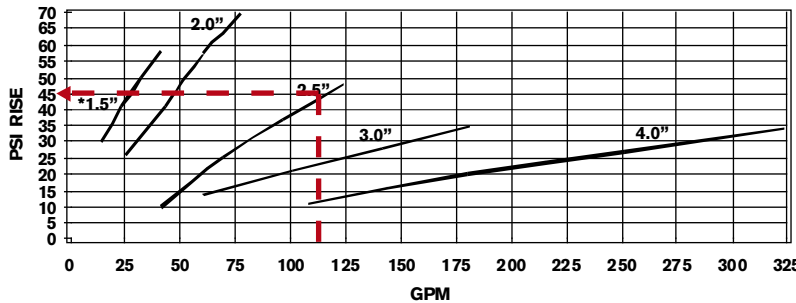

#### Reseating Pressure:

Total relief line pressure must drop by 18 psi (1 bar) for reseating.

(See notes below)

#### \* Valve Seat Size

Pressure rise and reseating values are estimated based on water at 70°F (21°C).

Results can vary subject to flow conditions and product properties. For pressure rise curves on viscous fluids, please contact factory.

**NOTE: Not for use as an ASME-coded relief valve.**

#### Chart Guide

1. Locate curve for selected actuator size and valve seat size.
2. Where relief flow rate intersects curve, determine pressure rise.
3. Add pressure-rise to relief-pressure and relief-path line-pressure loss, elevation loss, destination pressure etc. For estimated total pressure during relief.
4. Use reseal pressure to gauge minimum differential between set pressure and normal operating pressure.

RESEATING PRESSURE		
VALVE SEAT SIZE INCHES (mm)	Reduction in pressure from set pressure psi (bar)	
	WR61	WR63
1.5" (38)	20 (1 bar)	30 (2 bar)
2" (51)	12 (.8 bar)	22 (2 bar)
2.5" (64)	8 (.5 bar)	18 (1 bar)
3" (76)	5 (.3 bar)	15 (1 bar)
4" (102)	5 (.3 bar)	15 (1 bar)

## ADDITIONAL TECHNICAL DATA

### WR61 DATA

#### Maximum Holding Pressure\* Per Valve Size From W61 Valve Chart

PLUG SIZE INCHES (mm)	ACTUATOR SIZE psi (bar)		
	4" HAR	5" HAR	6" HAR
1.5" (38)	177 (12)	378 (26)	602 (42)
2.0" (51)	99 (7)	212 (15)	338 (23)
2.5" (64)	64 (4)	136 (9)	216 (15)
3.0" (76)	44 (3)	94 (6)	150 (10)
4.0" (102)	25 (2)	54 (4)	87 (6)

#### Pressure\* Change Per Turn of Adjusting Screw

PLUG SIZE INCHES (mm)	ACTUATOR SIZE psi (bar)		
	4" RHAR	5" RHAR	6" RHAR
1.5" (38)	24 (2)	40 (3)	82 (6)
2.0" (51)	13 (.9)	23 (2)	46 (3)
2.5" (64)	9 (.6)	15 (1)	29 (2)
3.0" (76)	6 (.4)	10 (.7)	20 (1)
4.0" (102)	3 (.2)	6 (.4)	12 (.8)

Actual pressure change per turn of adjusting screw may be different due to variations between springs.

### WR63 DATA

#### Maximum Holding Pressure\* Per Valve Size From W63 Valve Chart

PLUG SIZE INCHES (mm)	ACTUATOR SIZE psi (bar)		
	4" HAL	5" HAL	6" HAL
1.5" (38)**	233 (16)	497 (34)	659 (45)
2.0" (51)	114 (8)	244 (17)	323 (22)
2.5" (64)	69 (5)	147 (10)	195 (13)
3.0" (76)	46 (3)	99 (7)	131 (9)
4.0" (102)	24 (2)	52 (4)	68 (5)

#### Pressure\* Change Per Turn of Adjusting Screw

PLUG SIZE INCHES (mm)	ACTUATOR SIZE psi (bar)		
	4" RHAL	5" RHAL	6" RHAL
1.5" (38)**	32 (2)	53 (4)	90 (6)
2.0" (51)	16 (1)	26 (2)	44 (3)
2.5" (64)	9 (.6)	16 (1)	27 (2)
3.0" (76)	6 (.4)	11 (.7)	18 (1)
4.0" (102)	3 (.2)	6 (.4)	9 (.6)

Actual pressure change per turn of adjusting screw may be different due to variations between springs.

\*Review valve features and port connections to determine pressure limitations.

\*\* WR63 not available with 1.5" (38 mm) body size due to limitations on pressure adjustment to 0 psi (0 bar) relief pressure. It is only available with larger body sizes and 1.5" (38 mm) reduced seat insert.

## W60 SERIES VALVES: SAFE, STRONG AND SANITARY

### Cleanable, designed for sanitary / hygienic applications

- 316L Stainless Steel wetted parts
- Minimal internal crevices and high surface finishes
- Free-spinning, snap-on seats for reliable sealing: choice of Tef-Flow™, Tef-Flow™ P, Tri-Ring, or metal
- Captive, supported stationary seals located forward to the product zone: choice of o-ring, quad, or wiping stem seals
- Free draining in multiple positions – including upside down
- 3-A compliant, FDA approved materials, EHDGE certified

### Heavy-duty construction

- Machined-from-bar body construction can withstand mishandlings of active plant environment and lead to long service life
- Consistently thick body wall dimensions and laser welded port extensions minimize body distortion during manifolding and extreme fluid temperature changes
- Deep, inter-locking bodies and adapters
- Heavy-Duty Clamps and High Pressure Adapters for up to 1220 psi (84 bar) applications
- Multiple split TFM bearing support of stems

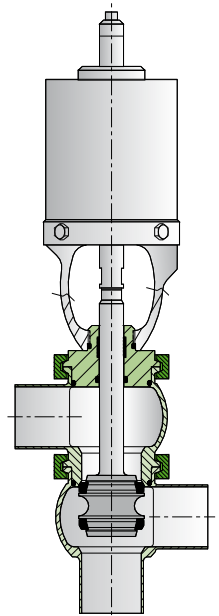

W62TT

### Flexibility and Modularity

- Major components (body, stem, adapter, actuators) are modular in design to quickly and easily assembly or retrofit in field a valve to meet specific applications
- Choice of standard fully maintainable actuator or cost-effective maintenance-free actuator with 5-year warranty with various sizes and spring options
- True-line mix body sizes and custom 45° or other angled ports available to match complicated pipe design
- One-piece bodies or two-piece clamped
- AL6XN alloy product zone parts for corrosive products
- Custom port lengths and center-to-center dimensions can match competitor and legacy series valves to provide easy drop-in replacements
- Various control top models available to fit customer needs: low cost APV CU4 or full-featured, robust WCB control tops

### Low cost of ownership

- Heavy-duty construction maximizes service life
- Minimum propriety parts gives off-the-shelf availability and low price of most spares and components
- Available spare parts from local distributor or factory in Delavan, WI
- Modular design enables multi-use parts, easy training and familiarity with whole family of valves, minimum spares required on shelf
- Long life standard actuator is field-maintainable with finger-safe, caged springs and cartridge piston assemblies
- Commonality of parts: same part numbers used multiple places
- Simple, easy-to-maintain design is intuitive and does not require advanced mechanical skills

## Made in Wisconsin for the unique needs of U.S. dairies

- Nationwide network of recognized solution providers and System Integrators for Dairy Processes
- Dependable spare parts - made and stocked in Wisconsin
- Nationwide Service network



# WR60/WR80 Series

**OVER-PRESSURE RELIEF  
VALVES**

# SPXFLOW

Based in Charlotte, North Carolina, SPX FLOW, Inc. (NYSE: FLOW) is a multi-industry manufacturing leader. For more information, please visit [www.spxflow.com](http://www.spxflow.com)

# SPXFLOW

**SPX FLOW** 611 Sugar Creek Road Delavan, WI 53115  
P: (262) 728-1900 or (800) 252-5200 E: [wcb@spxflow.com](mailto:wcb@spxflow.com)

SPX FLOW, Inc. reserves the right to incorporate our latest design and material changes without notice or obligation.

Design features, materials of construction and dimensional data, as described in this bulletin, are provided for your information only and should not be relied upon unless confirmed in writing. Please contact your local sales representative for product availability in your region. For more information visit [www.spxflow.com](http://www.spxflow.com).

The green "s" and "x" are trademarks of SPX FLOW, Inc.

WCB\_Valves-WR60-WR80\_DST\_US

Version: 04/2022

COPYRIGHT © 2022 SPX FLOW, Inc.

Identification Number: DS-1224