

# Cartridge Aerator or Bilge Pump

52289-web / US ONLY

ORIGINAL INSTRUCTIONS/TRANSLATION OF ORIGINAL INSTRUCTIONS  
READ AND UNDERSTAND THIS MANUAL PRIOR TO OPERATING OR  
SERVICING THIS PRODUCT



Please follow the easy installation instructions carefully to assure maximum efficiency in your bilge pump operation.

## **Cartridge Bilge Pump Installation Instructions**

1. Mount pump at lowest point in the bilge.
2. Select a point where bilge water is to be pumped overboard, at least 1 foot above the water line and the shortest distance from the pump. Install a 3/4" thru hull (Johnson Pump) P/N 7509. A 1 1/16" hole is required.
3. Fasten a 3/4" fuel resistant hose from pump outlet to the thru hull fitting. Avoid sharp bends or loops. Support hose if necessary. It is important that the hose be constantly rising and not be allowed to dip below the outlet port. For maximum performance use smooth bore, reinforced hose.

## **Wiring The Pump**

1. Connect the brown wire to the positive (+) fused side of the battery.
2. Connect the black wire to the negative (-) side of the battery.
3. Do not cut back insulation more than 3" and keep all connections well above water levels. A submerged splice will render the warranty void.
4. Fuse sizes for models:

3250	requires 5A
3270	requires 5A
3290	requires 5A
5. For longer pump life, do not run dry.

## To Automate The Pump With Johnson Pump Electro-Magnetic Float Switch

Follow the wiring diagram below, observing all the cautions from the wiring instructions.

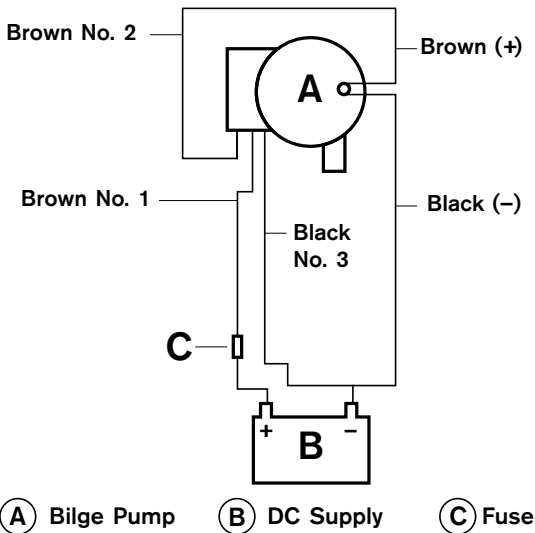

## To Remove Or Replace Power Cartridge

1. Lift tab and rotate the two fins in a counter clockwise direction and lift out (fig. 1,2, & 3).
2. To reinstall, first make sure the "O" Ring is properly located (Fig. 4). Coat the "O" Ring with a light film of vegetable oil or mineral oil, then align the two cams on either side of the power cartridge with the two slots in the outer housing. Press down and twist in a clockwise rotation. To ensure that the power cartridge is properly located, twist fins in a counter clockwise direction without lifting tab. Cartridge should stay in place.

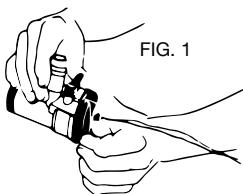

FIG. 2

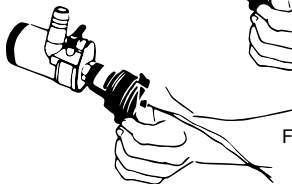
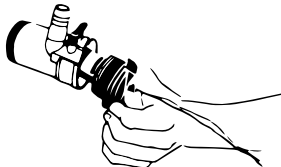
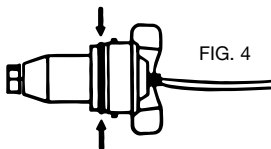
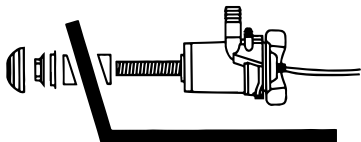

FIG. 3



## Cartridge Aerator Pump Installation Instructions



1. Drill a 1 1/16" hole through the transom well below the water line.
2. Caulk the threaded shaft on the pump and insert the threaded shaft through the hole. NOTE: Silicone sealants are not recommended. If the transom has a severe angle use transom shims 7124 to level pump.
3. Tighten the nut and saw off the excess threaded shaft. Make certain the pump outlet is pointing straight up before tightening shaft nut.
4. Connect the pump leads to any convenient 12 V DC power source. Connect the brown lead to the positive side and the black lead to the negative side. A convenient on/off dash switch is available from your Johnson Pump dealer (Part no. 7204)

Fuse sizes: Model 2850 requires 5A

Model 2870 requires 5A

Model 3850 requires 5A

Model 3870 requires 5A

5. Connect a 3/4" reinforced hose from the pump discharge to the livewell or spray bar.
6. The unit is now ready for operation.

To clean or replace power cartridge, **first block off the thru hull inlet**. Then lift the tab and rotate the two fins in a counter clockwise direction and lift out (see Figures 1, 2, and 3 on previous page).

To reinstall the power cartridge unit, first **make sure the "O" Ring is properly located** (see Figure 4 on previous page). Coat the "O" Ring with a light film of vegetable oil or mineral oil, then align the two cams on either side of the power cartridge unit with the two slots in the pump housing. Press down and rotate in a clockwise rotation. To ensure that the power cartridge is properly installed, twist the fins in a counter clockwise direction without lifting tab. Cartridge should stay in place and not move.

Unblock the thru-hull inlet if it was blocked and reattach power leads (see step 4 of the installation instructions above).

## Use Of Check Valve (Bilge Pump Only)

The check valve supplied with your cartridge pump is used to prevent the backflow of water. The utilization of the check valve requires you to be mindful of its functionality. The check valve material is made of Nitrile material to be used for water applications only. Also, the check valve will reduce the flow of the pump. If flow is critical to the application of the pump, it is recommended that the check valve not be used. Also, when winterizing your boat, remove the check valve to avoid ice formation and/or degradation of the check valve.

### Installation:

Install check valve such that the tapered end is towards the direction of flow. To install check valve, **remove gasket** in Duraport and replace the gas-ket with the check valve which also acts as the gasket. **Save the gasket** in case you intend to not use the check valve at a later time.

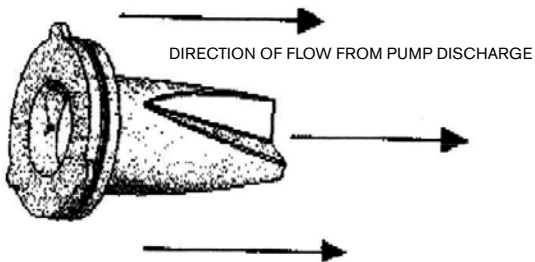

# THREADED DISCHARGE PORT SUPPLEMENTAL INSTRUCTIONS:

## UNASSEMBLED FITTINGS

1. Install the appropriate barb fitting straight or 90 degree into the  $\frac{3}{4}$  inch connector nut; place the sealing washer into the connector nut afterwards.
2. Install the hose clamp loosely on the discharge hose and install the hose onto the barb. Tighten the hose clamp securely.
3. Thread the assembled connector nut onto the pump discharge port, position the hose and hand tighten the connector nut, tighten the assembly  $\frac{1}{4}$  turn past hand tightness.

## PRE-ASSEMBLED FITTINGS

1. Install the hose clamp loosely on the discharge hose, install the hose onto the barb fitting and position as necessary. Tighten the hose clamp securely.
2. Check the tightness of the connector nut.

**THREADED NUTS DO NOT REQUIRE MECHANICAL TIGHTENING.  
DO NOT OVER TIGHTEN, DAMAGE MAY OCCUR**

*Marine type sealants are not required,  
periodic check for tightness is recommended.*

## PART NUMBERS:



SPX FLOW, 5885 11th Street, Rockford, Illinois 61109

warrants to the original consumer purchaser that this bilge pump will be free from defects in material and workmanship, providing that the case is not opened or the pump otherwise abused for a period of 3 years from the date originally purchased.

IMPORTANT: FOR THIS WARRANTY TO BE EFFECTIVE, SPX FLOW INC. MUST BE SUPPLIED WITH THE ORIGINAL PURCHASE DATE OF THE PUMP. THE ACCEPTANCE BY SPX FLOW INC. OF ANY PUMP RETURNED SHALL NOT BE DEEMED AN ADMISSION THAT SUCH PUMP IS DEFECTIVE OR IN VIOLATION OF ANY WARRANTY. THE COMPANY RESERVES THE RIGHT TO REPAIR OR REPLACE THE PUMP. NO REPRESENTATIVE OR OTHER PERSON IS AUTHORIZED TO ASSUME FOR SPX FLOW INC. ANY ADDITIONAL LIABILITY IN CONNECTION WITH THE SALE OF ITS PRODUCTS OR TO ALTER THIS WARRANTY IN ANY WAY. IN NO EVENT WILL SPX FLOW INC. WILL BE LIABLE FOR MORE THAN THE SALES PRICE OF THE PUMP. UNDER NO CIRCUMSTANCES WILL SPX FLOW INC. BE LIABLE FOR ANY LOST PROFITS, INCIDENTAL OR CONSEQUENTIAL COSTS, EXPENSES, OR DAMAGES. THE LIMITATION ON LIABILITY FOR LOST PROFITS, INCIDENTAL OR CONSEQUENTIAL COST EXPENSES OR DAMAGES SHALL SURVIVE ANY FAILURE OF ESSENTIAL PURPOSE OF THIS LIMITED WARRANTY.

Some states do not allow the exclusive or limitation of incidental or consequential damages, so the above limitation may not apply to you. NO EXPRESS OR LIMITED WARRANTY, INCLUDING WARRANTY OF MERCHANTABILITY AND FITNESS SHALL EXTEND FOR ANY PERIOD OF TIME GREATER THAN 3 YEARS FROM THE DATE OF ORIGINAL PURCHASE OF THIS PRODUCT. Some states do not allow limitation on how long an implied warranty lasts so the above limitation may not apply to you.

CAUTION - Warranty void if seal on pump is broken, if any electric cord is cut back more than 3 inches, if electric splices become submerged, or if pump is installed contrary to instructions or warnings.

Bilge Pumps are designed to exhaust standing water only. These pumps are not intended for damage control. Bilge Pump capacities may not be sufficient to prevent flooding from rapid accumulation of water due to storms, rough weather and/or rapid leaks created by hull damages or unsafe navigational conditions.





## **WARNING:**

THIS PUMP IS DESIGNED TO PUMP FRESH WATER AND SALT WATER ONLY. DO NOT PUMP OIL, DIESEL FUEL, GASOLINE OR OTHER FLAMMABLE LIQUIDS WITH THIS PUMP. DO NOT EXPOSE PUMP TO LIQUIDS AND CHEMICALS THAT ARE NOT COMPATIBLE WITH ABS PLASTIC. THIS PUMP DOES NOT PREVENT THE DISCHARGE OF OIL OR OTHER CHEMICALS INTO THE WATER. DO NOT DISCHARGE OIL OR OTHER CHEMICALS INTO THE ENVIRONMENT. WHEN SERVICING THE PUMP, ALWAYS DISCONNECT POWER. USE THE SPECIFIED FUSE SIZES. BILGE PUMPS ARE DESIGNED TO EVACUATE STANDING WATER ONLY. BILGE PUMPS ARE NOT DESIGNED TO PREVENT BOAT SINKAGE DUE TO STORMS, ROUGH WEATHER, UNSAFE BOATING, WRONG INSTALLATION OR OTHER DAMAGES.

# SPXFLOW

Cartridge Aerator  
or Bilge Pump

## CUSTOMER SERVICE & SUPPORT

1 847 671-7867

[jp-customerservice@spxflow.com](mailto:jp-customerservice@spxflow.com)

For more information about our worldwide locations, approvals, certifications, and local representatives, visit Johnson Pump-Marine at [www.spxflow.com](http://www.spxflow.com)

SPX FLOW, Inc. reserves the right to incorporate our latest design and material changes without notice or obligation.

Design features, materials of construction and dimensional data, as described in this bulletin, are provided for your information only and should not be relied upon unless confirmed in writing. Please contact your local sales representative for product availability in your region.

For more information visit [www.spxflow.com](http://www.spxflow.com).

“>” and “X” are trademarks of SPX FLOW, Inc.



ISO  
8846  
8849

**> Johnson  
Pump®**