

CU4plus AS-interface V1 - V2

CONTROL UNIT

FORM NO.: H333978 REVISION: GB-6

READ AND UNDERSTAND THIS MANUAL PRIOR TO OPERATING OR SERVICING THIS PRODUCT.



We,

DESIGN CENTER/MANUFACTURER: SPX Flow Technology Germany GmbH
Gottlieb-Daimler-Str. 13, D-59439 Holzwickede

MANUFACTURING FACILITY: SPX Flow Technology Poland sp. z o.o.
Rolbieskiego 2, 85-862 Bydgoszcz, Poland

AUTHORIZED REPRESENTATIVE: SPX Flow Europe Ltd.
(for UKCA) Building A, Compass House, Manor Royal
Crawley, RH10 9PY

declare under our sole responsibility that the

SPX FLOW APV brand Control Units of the series
CU4 Direct Connect and AS-interface Control Unit
CU4plus Direct Connect, AS-interface and IO-Link Control Units
CU4 110V Module (*)

meet the requirements of the
Electromagnetic Compatibility Directive 2014/30/EU
& protection class IP 67 EN 60529, EN 61000-6-2, EN 61000-6-4, EN 60068-2-6
RoHS Directive 2011/65/EU
Low Voltage Directive 2014/35/EU (*only applicable for APV CU4 110V Module)

Holzwickede, November 2022



Dr.-Ing. Behdad Ariatabar, Design Center Lead - Valves

meet the requirements of the
Electromagnetic Compatibility Regulations 2016 No. 1091 & BS harmonized standards
Restriction of Use of Certain Hazardous Substances in Electrical and Electronic Equipment Regulation 2012 No. 3032
Electrical Equipment (Safety) Regulations 2016 No. 1101 (*only applicable for APV CU4 110V Module)

Crawley, November 2022



Ewout Roozendaal, Director Global Pricing

Content	Page
1. Abbreviations and Definitions	6
2. Safety Instructions	6
2.1. Sentinels	
2.2. Intended use	
2.3. General regulations for careful handling	
2.4. Welding instructions	
2.5. Persons	
2.6. Warranty	
2.7. Important safety instructions for AS-interface networks	
3. General Terms	12
3.1. Purpose of use	
3.2. Design of CU4plus AS-interface	
3.3. Function of the individual components	
4. Mechanics and Pneumatics	15
4.1. Air connections for turning actuator	
4.2. Air connections seat valves and double seat mix proof valves	
4.3. Pressure relief valve	
4.4. Functional description - block diagrams	
4.5. Technical data / Standards	
4.6. Solenoid valves	
4.7. Throttling function	
4.8. NOT element	
5. Adapter	31
5.1. Valves with turning actuator, e.g. butterfly valve	
5.2. Single seat valve	
5.3. Double seat mix proof valve DE3, DA3+	
5.4. Double seat mix proof valves D4, D4 SL, D4 PMO, DA4	
5.5. Double seat tank outlet valve DT4 SL and AM1 aseptic mixproof valve	
6. Electronic Module	33
6.1. Function/block diagram	
6.2. Functional description of connections	
6.3. Technical data	
6.4. Connections	
6.5. LED indications	
6.6. Adjustment of valve profiles	
6.7. AS-i communication / Data signals	
6.8. Service and Maintenance Software CU4plus Toolbox	
6.9. Seat Pulsation - Efficiency in Cleaning	
7. Valve Position Indication	56
7.1. Continuously measuring valve position measuring system	
7.2. Tolerance band of the valve position measuring system	
7.3. Adjustment of valve position indication / Teach-in	
7.4. Use of external sensors	
8. CU Assembly and Startup	59
8.1. Valves with turning actuator, e.g. for butterfly valve	
8.2. Single seat valve	
8.3. Double seat valve DA3+ with activated Seat Lift Detection (SLD)	
8.4. Double seat mix proof valves D4, D4 SL, D4 PMO, DA4	
8.5. Double seat tank outlet valve DT4 SL	
8.6. Aseptic Double seat mix proof valve	
8.7. Pre-settings	
8.7. Pre-settings	
8.8. Replacement of CU3 versions	
9. Accessories and Tools	77
10. Service	78
10.1. Dismantling	
11. Trouble Shooting	79
12. Spare Parts Lists	81

1. Abbreviations and Definitions

A	Exhaust air
AWG	American Wire Gauge
CE	Communauté Européenne
CU	Control Unit
DI	Digital Input
DO	Digital Output
EMV	Electromagnetic Compatibility
EU	European Union
GND	Ground/mass potential
IP	International Protection
LED	Luminous diode
N	Pneumatic Air Connection NOT element
NEMA	National Electrical Manufacturers Association
P	Supply Air Connection
PELV	Protected Extra-Low Voltage
PWM	Pulse-width modulation
Y	Pneumatic Air Connection
SLD	Seat Lift Detection / Seat Lift Gathering

2. Safety Instructions

2.1. Sentinels

Meaning:



Danger!

Direct danger which can lead to severe bodily harm or to death!



Caution!

Dangerous situation which can lead to bodily harm and/or material damage.



Attention!

Risk as a result of electric current.



Note!

Important technical information or recommendation.

These special safety instructions point directly to the respective handling instructions. They are accentuated by the corresponding symbol. Carefully read the instructions to which the sentinels refer. Continue handling the control unit only after having read these instructions.

2. Safety Instructions

2.2. Intended use

The CU4plus AS-i control unit is only intended for use as described in chapter 3.1. Use beyond that described in chapter 3.1. do not comply with the regulations and SPX FLOW shall not be responsible for any damage resulting from this non-observance. The operator bears the full risk. Prerequisites for proper and safe operation of the control unit are the appropriate transport and storing as well as the professional assembly. Intended use also means the observance of operating, service and maintenance conditions.

2.3. General regulations for careful handling

To ensure a faultless function of the unit and a long service life, the information given in this instruction manual as well as the operating conditions and permissible data specified in the data sheets of the control unit for process valves should be strictly adhered to.

- The operator is committed to operating the control unit in faultless condition, only.
- Observe the general technical rules while using and operating the unit.
- Observe the relevant accident prevention regulations, the national rules of the user country as well as your company-internal operating and safety regulations during operation and maintenance of the unit.
- Switch off the electrical power supply before carrying out any work on the system!
- Note that piping or valves that are under pressure must not be removed from a system!
- Take suitable measures to prevent unintentional operation or impermissible impairment.
- Following an interruption of the electrical or pneumatic supply, ensure a defined and controlled re-start of the process!
- If these instructions are not observed, we will not accept any liability. Warranties on units, devices and accessories will expire!

2. Safety Instructions



2.4. Welding instructions

It is generally recommended to avoid welding work in process installation in which control units are installed and connected. If welding is nonetheless required, earthing of the electrical devices in the welding area is a necessity.



2.5. Persons

- Installation and maintenance work may only be carried out by qualified personnel and by means of appropriate tools.
- Qualified personnel must get a special training with regard to possible risks and must know and observe the safety instructions indicated in the instruction manual.
- Work at the electrical installation may only be carried out by personnel specialized in electrics!

2.6. Warranty

This document does not contain any warranty acceptance. We refer to our general terms of sale and delivery. Prerequisite for a guarantee is the correct use of the unit in compliance with the specified conditions of application.



Note!

This warranty only applies to the Control Unit. No liability will be accepted for consequential damage of any kind arising from failure or malfunction of the device.

2. Safety Instructions

2.7. Important safety instructions for AS-interface networks

Aside from complying with the Installation Guidelines according to AS-i Specification, observe the following instructions!

2.7.1 Earthing

- The PE connection of the AS-i power supply (protective earth) must (if existent) be grounded.
- The symmetry point of the AS-i network (GND, ground, shield) must be connected with the plant ground).
- Neither AS-i – nor AS-i + must be grounded.
- Use of earth-leakage relay, insulation monitoring modules is recommended.
- Use of surge protection modules is recommended.

2.7.2. Network design and voltage supply

- Use only AS-i certified power supplies.
- Output voltage 26.5 to 31.6 VDC
- AS-i power supplies deliver up to 8A.
- The voltage drop between power supply and bus device must not exceed 3V. If required, the power supply must be set closer to the slaves. Alternatively power supplies with repeaters can be extended to such an extent that up to 3 power supplies can be distributed over the whole bus, see fig.
- An AS-i segment including all stubs must not be longer than 100 m.
- Additional 100 m AS-i cable may be connected to each repeater, whereas not more than 2 repeaters (max. 2 connected in series) may be set between a slave and the master.
- A galvanically isolated AS-i power supply must be connected in every segment.

Extension with repeater

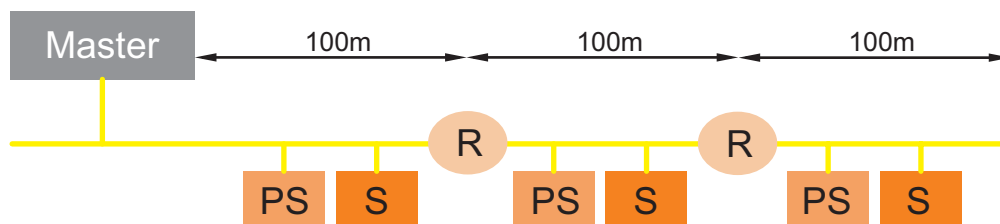

2. Safety Instructions

Extension with repeater to max. 500 m (central positioning)

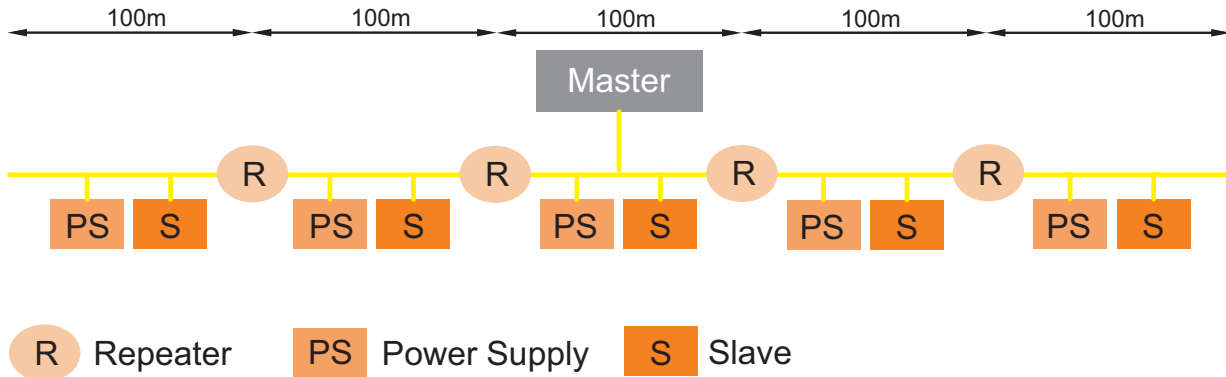

- AS-i power cables must be separated from the energy cables and must be as short as possible.
- External proximity switches must be connected to the slave as close as possible.
- Floating sensors/actuators: Grounding of galvanic peripheral devices connected with AS-i potential is not permitted. It must be avoided in terms of immunity to interference.

2.7.3. Selection of the appropriate power supply:

The max. electricity demand in the AS-i net (sum of all consumers) per segment must be smaller than the admissible current carrying capacity of the AS-i network (max. 90 %).

- The electricity demand of the individual slave results from the instruction manual. For the design of the networks a simultaneity factor can be integrated if necessary. A max. assignment of e.g. 62 slaves should be taken as a basis.
- At the end of each segment under full load, the AS-i voltage must be within the specification 26.5 to 31.6 V.

2.7.4. What has to be observed if a 8A AS-i power supply is used?

If more than the standard current of 2 A is transferred via the AS-i cables, the following boundary conditions must be considered when planning the net:

- The voltage drop along the AS-i line increases. For orientation purposes: If 2 A are transferred via one 100 m-long-cable with wire cross-section of 1.5 mm, the voltage drop amounts to 5 V.
- The contacts of the penetration technology are designed only for certain maximum permanent current which are partially below 8 A. Refer to the manufacturer datasheet!

2. Safety Instructions

2.7.5. Increase in interference resistance

- The connection „Schirm“ (shield) at the AS-i power supply unit must be connected directly and with good RF characteristics with the potential equalization of the machine or plant. This is not a grounding measure for safety reasons, but a functional grounding so that the AS-i line can be operated symmetrically against the earth. If a shielded cable is used, the cable shield must be connected there - and there only, as well.
- A good symmetrie must also be observed towards other electrical sources of interference (speed-controlled actuators, welding units etc.). The length of the connecting cables between the active slaves (CU4, CU4plus etc.) and the proximity switches connected to them must be limited to max. 2 m.
- When high electrostatic charge is expected (e.g. polishing machines, injection moulding machines, wrapping foils for plastic materials etc.) it may be required to take additional protective measures, such as the installation of arresters for static loads.

2.7.6. May the AS-i cable be laid in parallel to power cables?

- Although the communication via AS-i cable is not sensitive to EMC, it should be laid separately from line cables - also in control cabinets.
- Maximum distance to potential sources of interference (e.g. frequency converter) must be observed.
- Every AS-i wiring harness should have its own cable, i.e. AS-i cables should not be laid together with other cables in the same common cable.
- If it is required to lay single conductors (e.g. in control cabinets), parallel conductors must be laid. In case of standard stranded wires, lay and twist single conductors together.

3. General Terms

fig. 3.2.

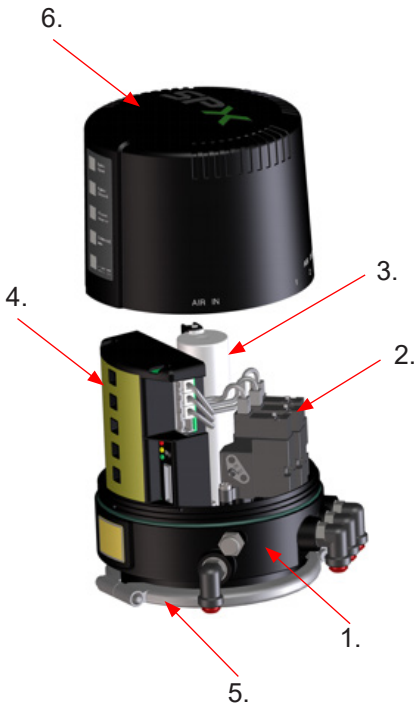

3.1. Purpose of use

The control unit CU4plus AS-i has been developed for the control of process valves in food processing industry as well as related industries.

The CU4plus AS-i control unit operates as interface between process control and process valve and controls the electric and pneumatic signals.

The pneumatic control of valves is undertaken via the solenoid valves. The control unit controls the valve positions, **open** and **closed**, via sensors. The electronic module undertakes the task to process the switching signal from the control and to control the corresponding solenoid valves. The electronic module also provides for potential-free contacts. The corresponding light signals in the control unit provide for an external indication of the valve positions.

3.2. Design of CU4plus AS-interface (fig. 3.2.)

The CU4plus AS-interface control unit consist of the following components:

1. The Control Unit base with integrated air channels and electric and pneumatic connections as well as viewing windows with type label.
2. 1 or 3 solenoid valves for the control of the valve actuators and for the seat lifting of double seat valves.
 - 1 solenoid valve with 1 logic NOT element for the control of the valve actuators.
3. Sensor module with integrated position measuring system for the detection of the valve position.
4. Electronic module for the electric supply, for the AS-i communication with the control, evaluation of feedback signals and control of solenoid valves as well as valve position indication through LED.
5. Clamp ring to fasten the CU4 on the adapter.
6. Cover with LED optics.

fig. 3.2.1

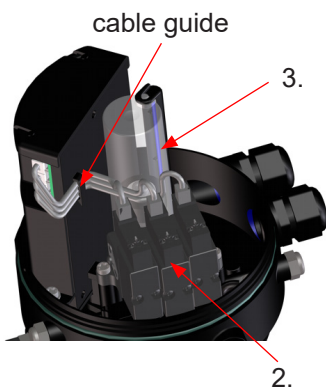

The cable/s by means of which the solenoid valves are connected with the electronic module must be guided through the cable guide at the rear side of the electronic module. **(fig. 3.2.1).**

3. General Terms

3.3. Function of the individual components

The installation of the control unit is undertaken by special adapters which are available for the different valves types, see **chapter 5**. Adapter. The snap connectors for supply air and pneumatic air to the individual cylinders at the valves are located at the outside of the control unit. At the control units for valves with turning actuator, the pneumatic air is transferred internally to the actuator. The air supply of the control unit is equipped with an exchangeable air filter. Observance of the required compressed air quality is imperative. Please also see **chapter 4.5** Technical Data.

The number of the solenoid valves installed in the CU4 depends on the valve actuators to be controlled. Single seat and butterfly valves and double seat valves without seat lift function require 1 solenoid valve.

Control units for double seat valves equipped with 3 solenoid valves. For the manual actuation, the solenoid valves are provided with a safe handle which is easy to operate.

The electronic module installed in the control unit fulfils the task to process the electric signals from the control, to control the solenoid valves and to evaluate the feedback signals from the feedback unit. Moreover, the signalling and indication of the valve positions as well as additional diagnostic functions are undertaken via the electronic module.

The electronic module is the interface between control actuators or sensors. Communication is undertaken via the standard AS-interface bus protocol according to specification V3.0.

Valve position detection is realized via a linear sensor which is integrated in the sensor module.

Control is effected via the target mounted to the valve rod. The measuring range of the linear sensor system detects the complete valve stroke. By means of the teach-in function, the corresponding position for closed and open valve position are detected and seat lift positions are permanently saved in the electronic module if required. (see **chapter 7.3** Teach-in function)

For the D4 and AM1 valve generations two linear sensors are used to monitor the close, open and the upper and lower seat lift position.

For DA3+ double seat valves with active seat lift detection (SLD) additionally to the linear sensor integrated in the CU, two external proximity switches installed at the valve actuator are required. The corresponding signals of the linear sensor as well as external proximity switches are evaluated in an internal logic circuit and, thus, the corresponding valve position indications are generated. (see **chapter 6.7**. Data signals, AS-i communication)

3. General Terms

3.3. Function of the individual components

The luminous diodes are located on the front side of the electronic module. Their signals are visibly indicated to the outside by an optical window in the cover the control unit. Beside the open and closed valve position, the existence of the operating voltage as well as different diagnostic information are indicated. **Chapter 6.6.** LED indicators provides more details.

The complete control unit has been designed on the building block principle. By exchange of the electronic module, the control type can be changed, e.g. from direct control (Direct Connect) to communication with AS-Interface.



Note! Wiring must be changed!

4. Mechanics and Pneumatics

4.1. Air connections for turning actuator

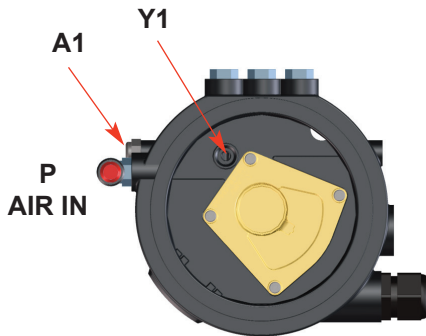

4.1.1. Function

CU41plus-T AS-i

design for valve with turning actuator, e.g. butterfly valves

- P** air supply with integrated particle filter
- Y1** bore to transfer control air to turning actuator
- A1** exhaust air, with exhaust silencer

4.2. Air connections seat valves and double seat mix proof valves

4.2.1. Function

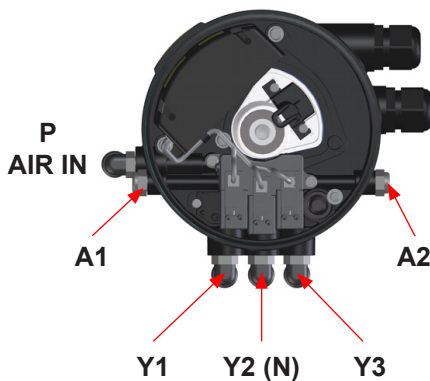

CU41plus-S AS-i

design for seat valves

- P** air supply with integrated particle filter
- Y1** pneumatic air connection for main actuator
- A1** exhaust air with silencer

CU41Nplus-S AS-i

design for seat valves with NOT element

- P** air supply with integrated particle filter
- Y1** pneumatic air connection for main actuator
- N** pneumatic air connection for the spring support of the actuator by compressed air via NOT element
- A1** exhaust air with silencer

CU41plus-M AS-i

design for DE3 double seat valves without seat lift function

- P** air supply with integrated particle filter
- Y1** pneumatic air connection for main actuator
- A1** exhaust air with silencer

CU43plus-M AS-i

design for DA3+ double seat valves with seat lift function

- P** air supply with integrated particle filter
- Y1** pneumatic air connection for main actuator
- Y2** pneumatic air connection for seat lift actuator of upper seat lifting
- Y3** pneumatic air connection for seat lift actuator of lower seat lifting
- A1/A2** exhaust air with silencer

4. Mechanics and Pneumatics

4.2.1. Function

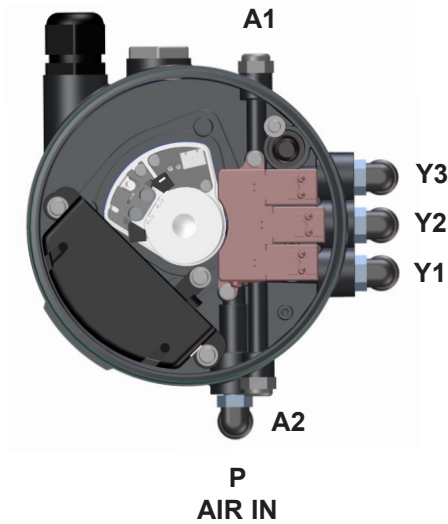

CU41plus-D4-V1-V2

**design for D4 double seat mix proof valves
without seat lift function**

- P** air supply with integrated particle filter
- Y1** control air connection for main actuator
- A1** exhaust air, with exhaust silencer

CU43plus-D4-V1-V2 / AM1

**design for D4 SL, DT4 SL, D4 PMO, DA4 double seat mix
proof and AM1 aseptic mixproof valves with seat lift function**

- P** air supply with integrated particle filter
- Y1** control air connection for main actuator
- Y2** pneumatic air connection for seat lift actuator of upper seat lifting
- Y3** pneumatic air connection for seat lift actuator of lower seat lifting
- A1/A2** exhaust air, with exhaust silencer

4. Mechanics and Pneumatics

4.3. Pressure relief valve

The base of the control unit is equipped with a pressure relief valve which prevents an inadmissible pressure build-up in the inner control unit.

If required, the pressure relief valve vents into the clearance between the base and the adapter of the control unit.



The pressure relief valve must not be mechanically blocked under any circumstances.

4. Mechanics and Pneumatics

4.4. Functional description - block diagrams



4.4.1. CU41plus AS-interface (internal position measuring system)

Valve types: SW4, MS4, UF4, UFMS4, SV1, SVS1F

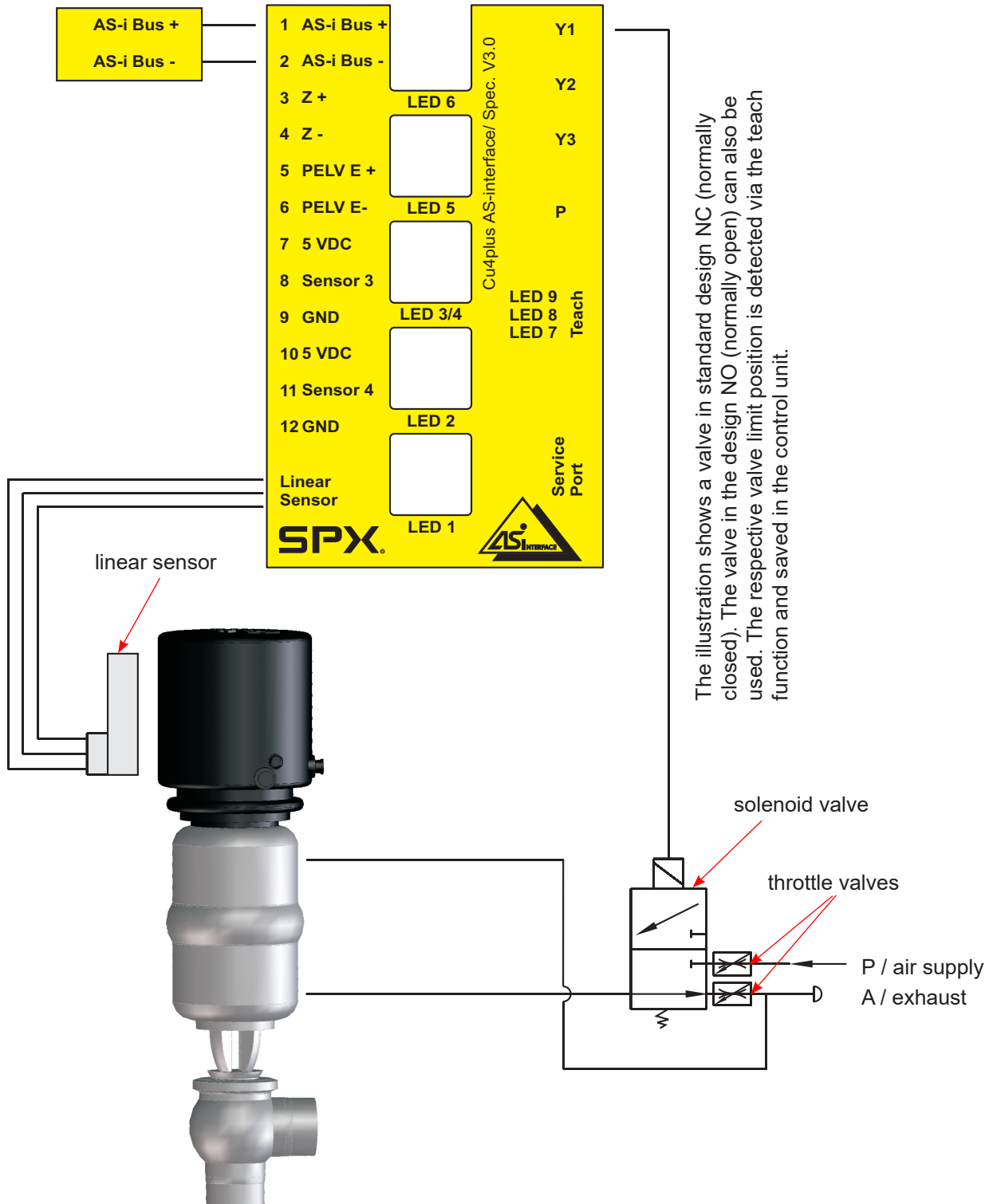

4. Mechanics and Pneumatics

4.4. Functional description - block diagrams



4.4.2. CU41Nplus AS-interface (internal position measuring system)

Valve type: SD4

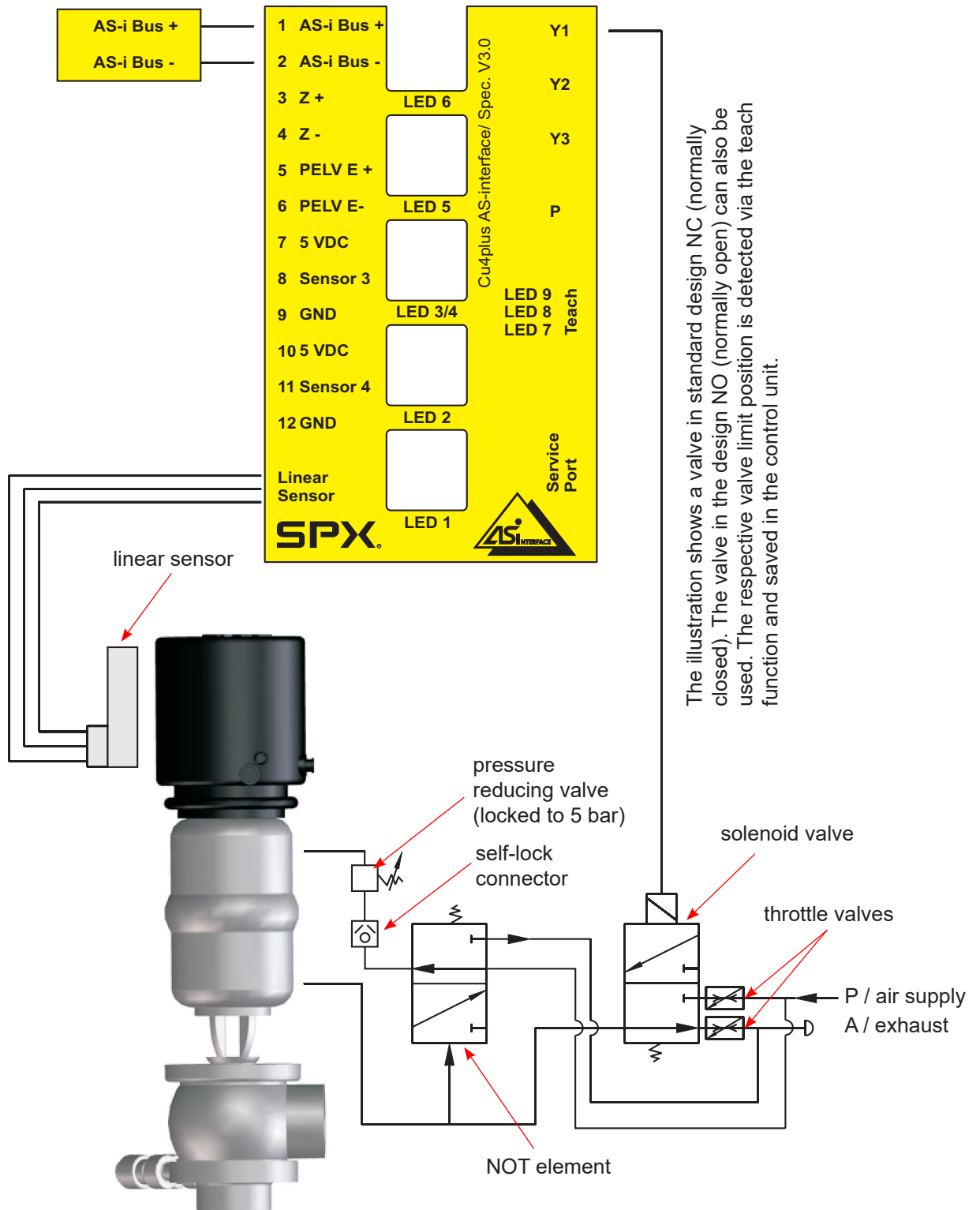

4. Mechanics and Pneumatics

4.4. Functional description - block diagrams



4.4.3. CU43plus AS-interface for DA3+SLD double seat valve (internal position measuring system and 2 external proximity switches)

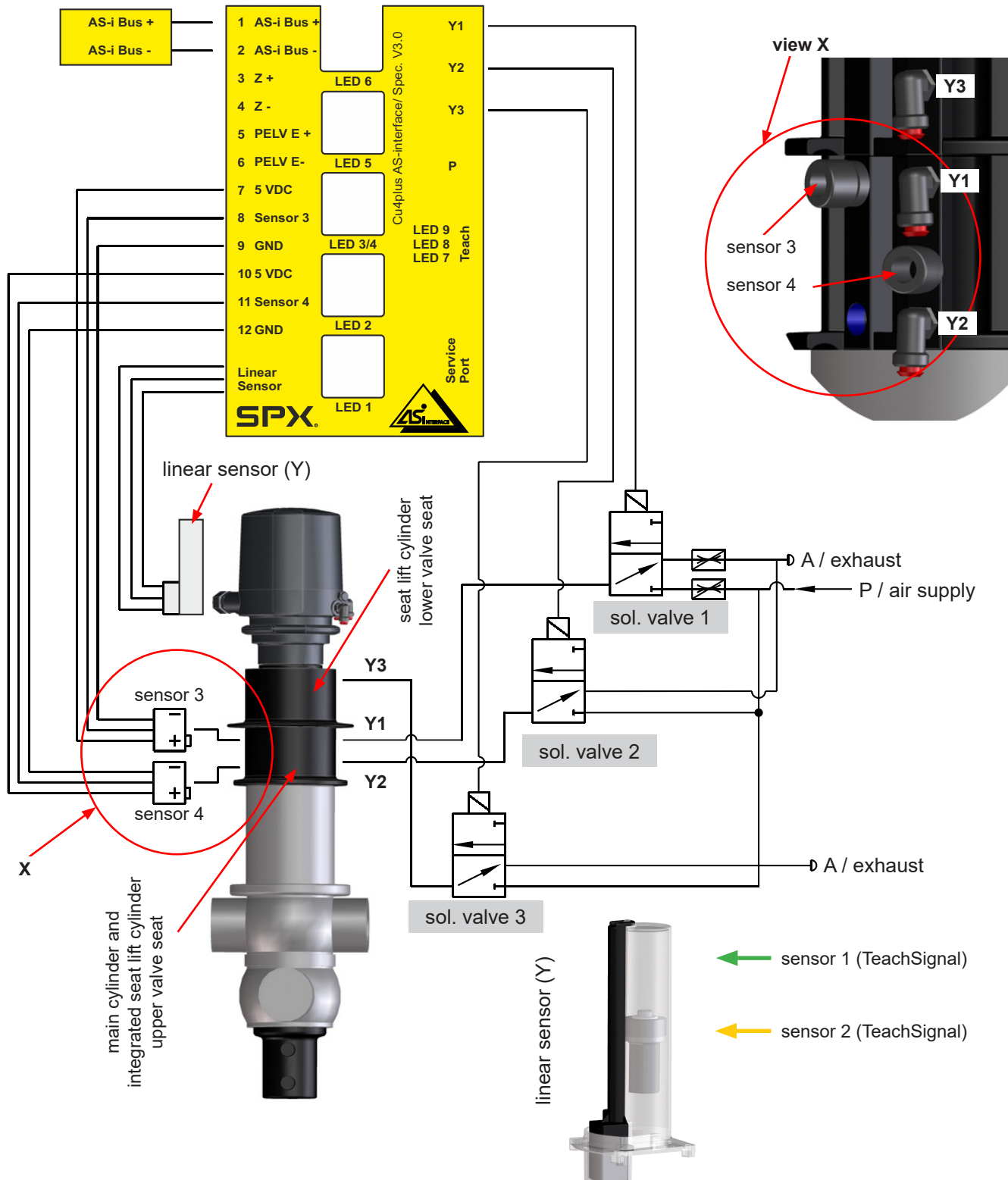

4. Mechanics and Pneumatics

4.4. Functional description - block diagrams



4.4.4. CU41plus-D4-V1 for D4 double seat mix proof valves

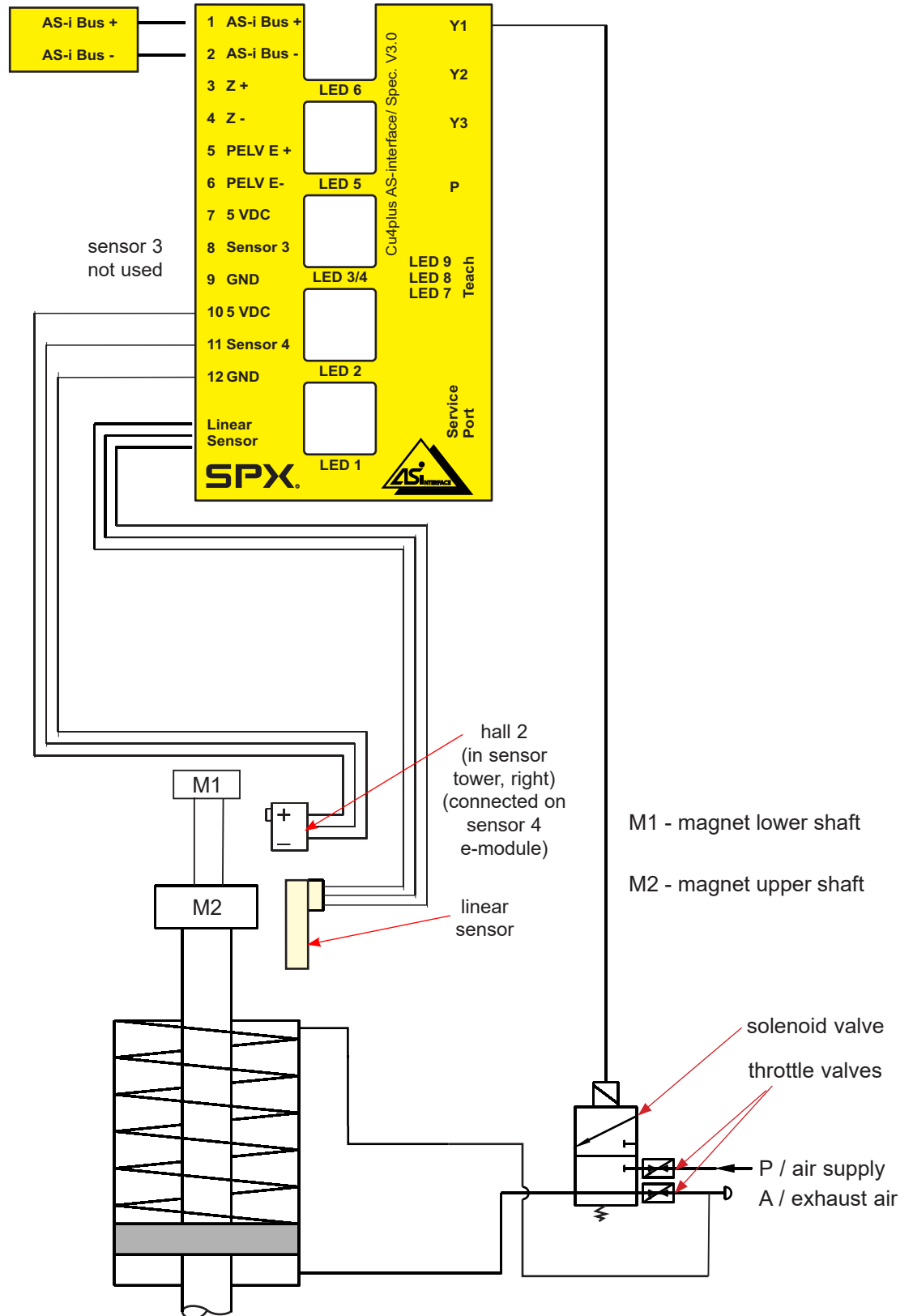

4. Mechanics and Pneumatics

4.4. Functional description - block diagrams



4.4.4. CU41plus-D4-V2 for D4 double seat mix proof valves

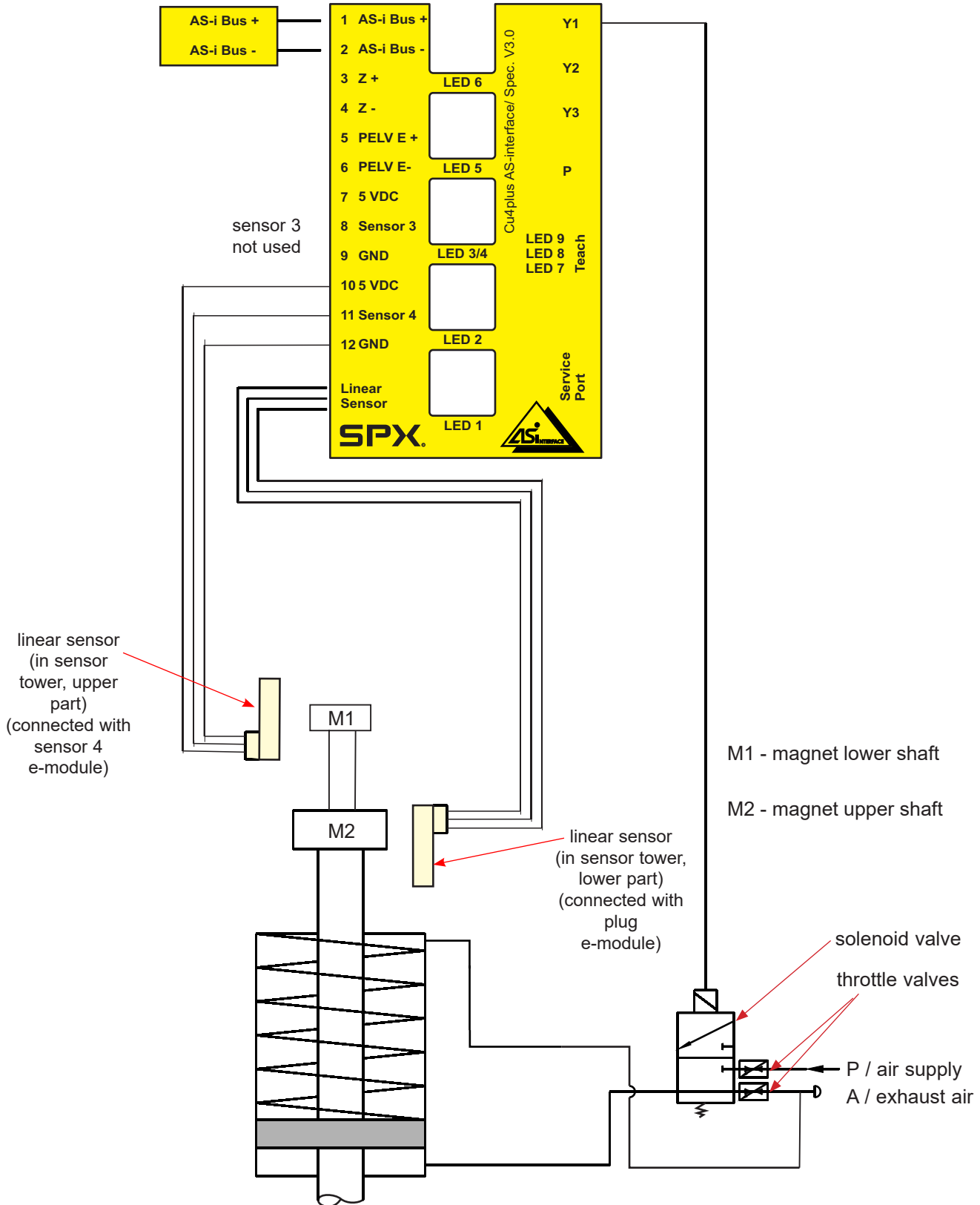

4. Mechanics and Pneumatics

4.4. Functional description - block diagrams



4.4.5. CU43plus-D4-V1 for D4 SL double seat mix proof valves

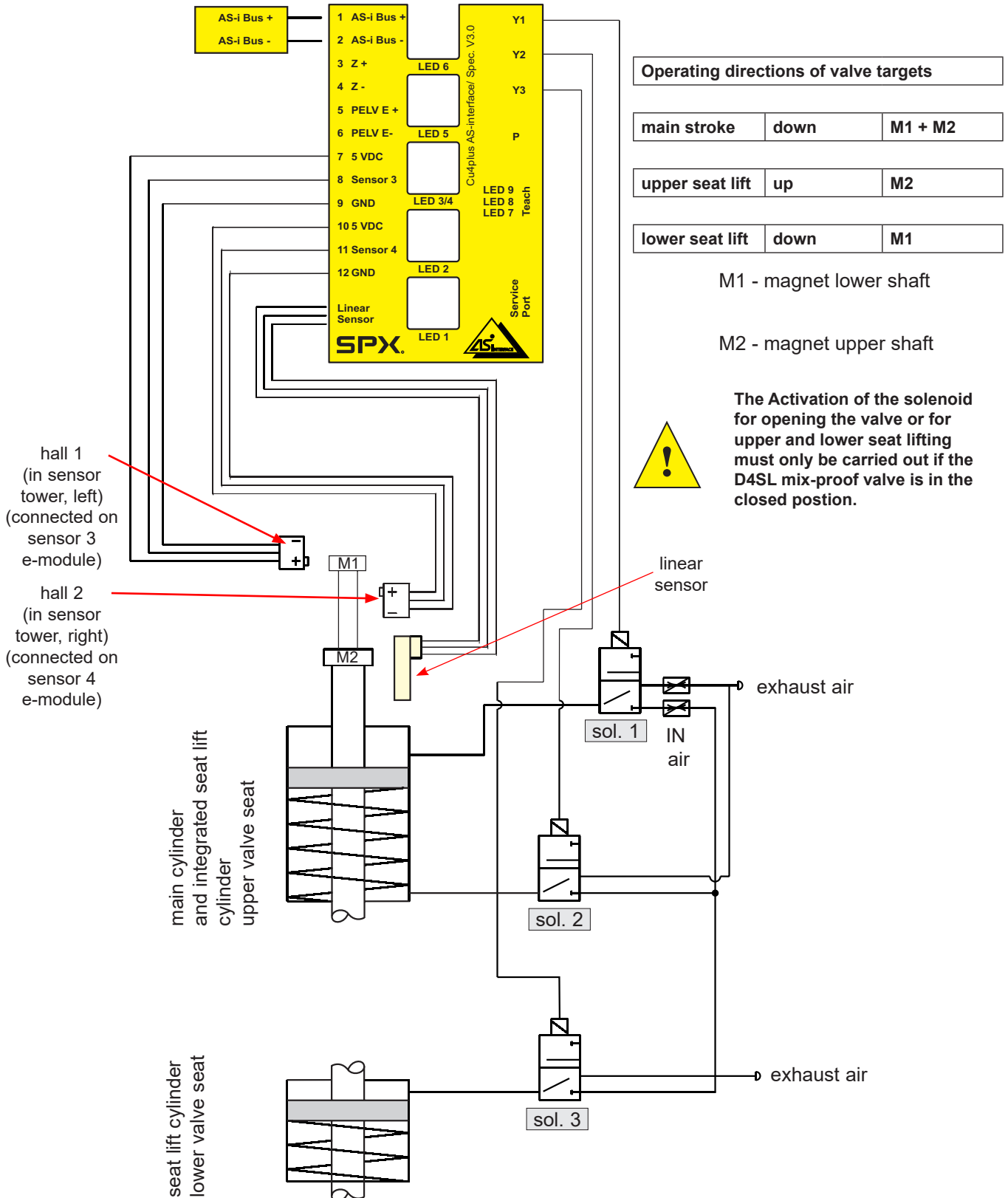

4. Mechanics and Pneumatics

4.4. Functional description - block diagrams



4.4.5. CU43plus-D4-V2 for D4 SL / D4 PMO double seat mix proof valves

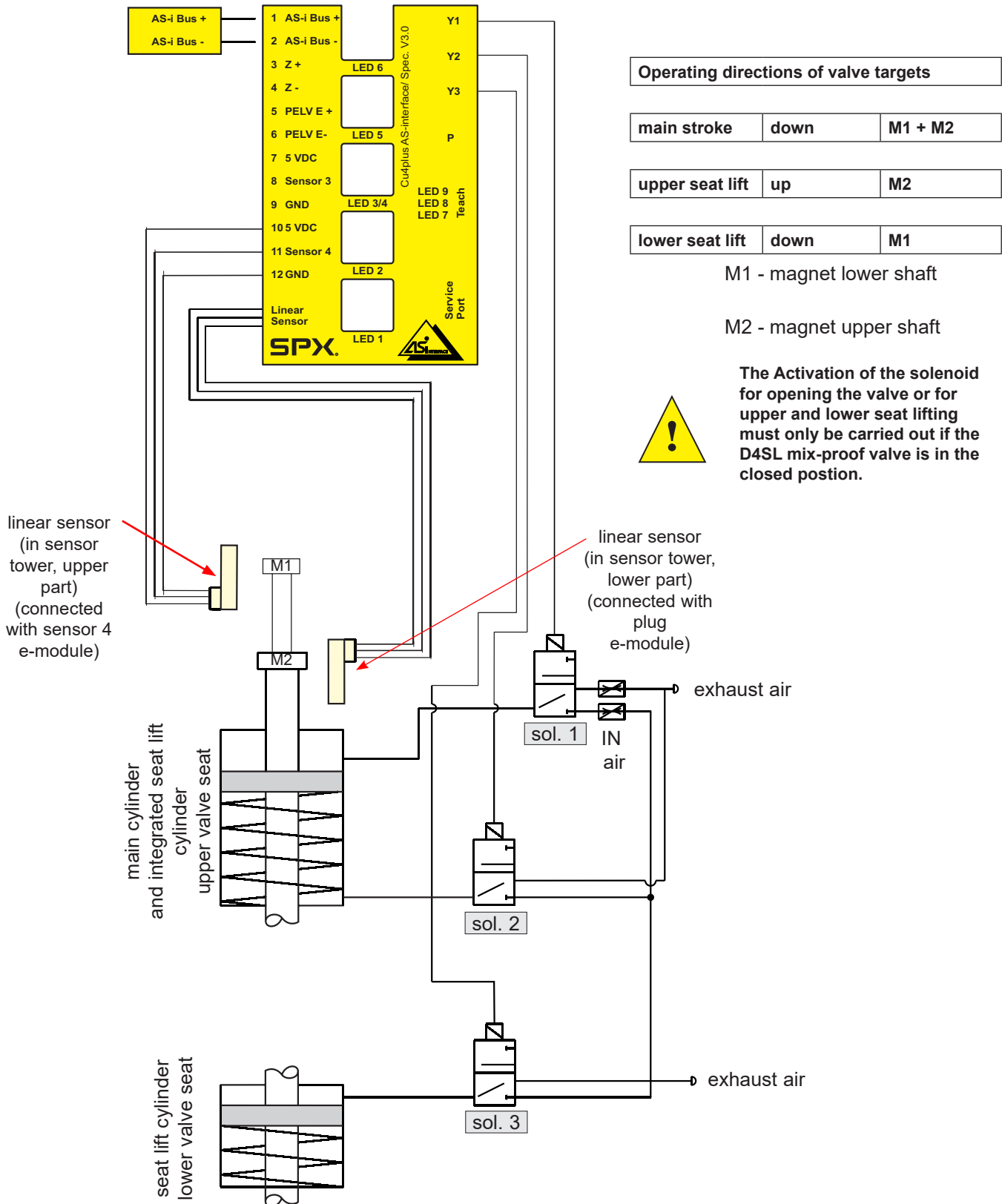

4. Mechanics and Pneumatics

4.4. Functional description - block diagrams



4.4.6. CU43plus-D4-V1 for DA4 double seat mix proof valves

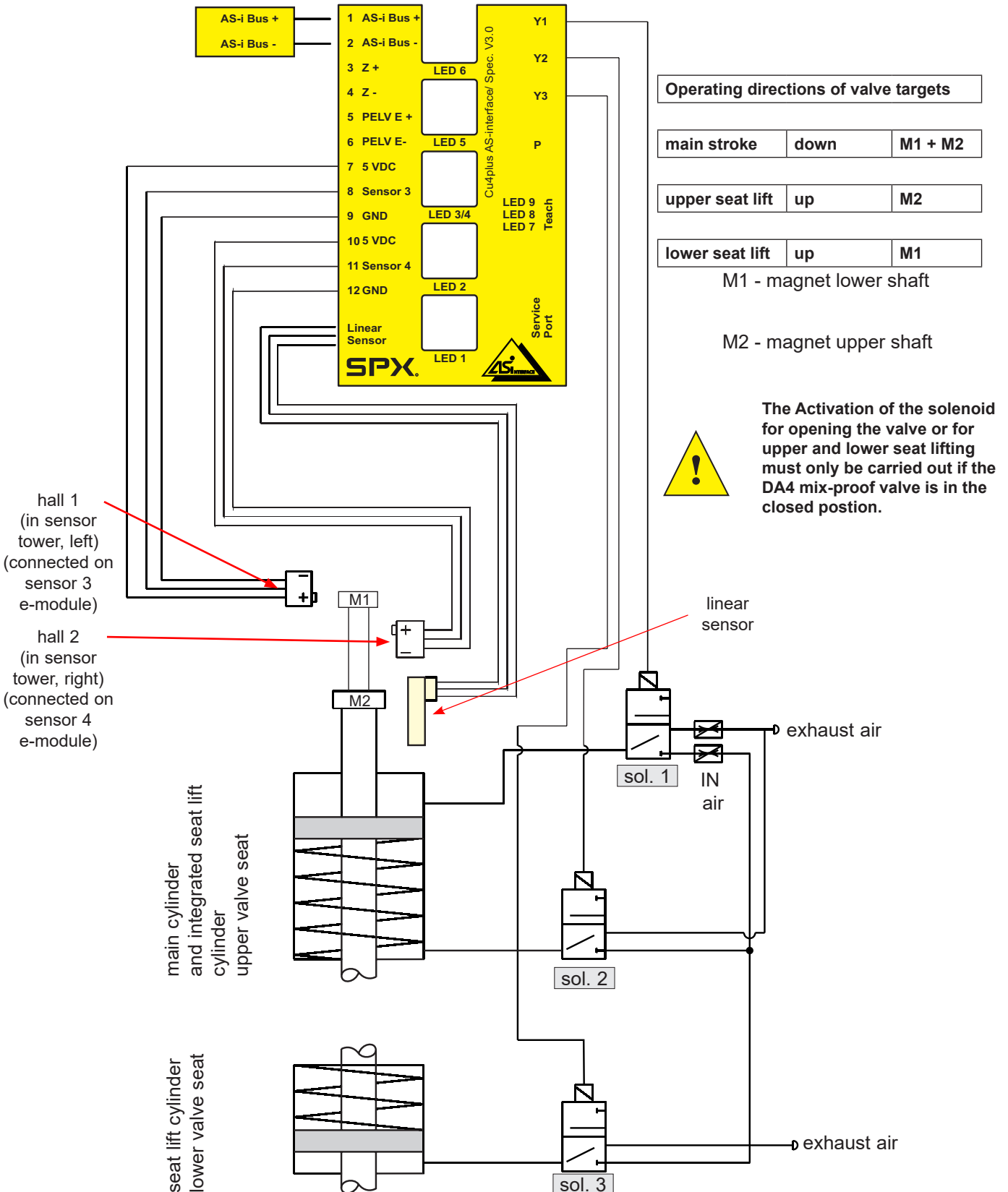

4. Mechanics and Pneumatics

4.4. Functional description - block diagrams



4.4.6. CU43plus-D4-V2 for DA4 double seat mix proof valves

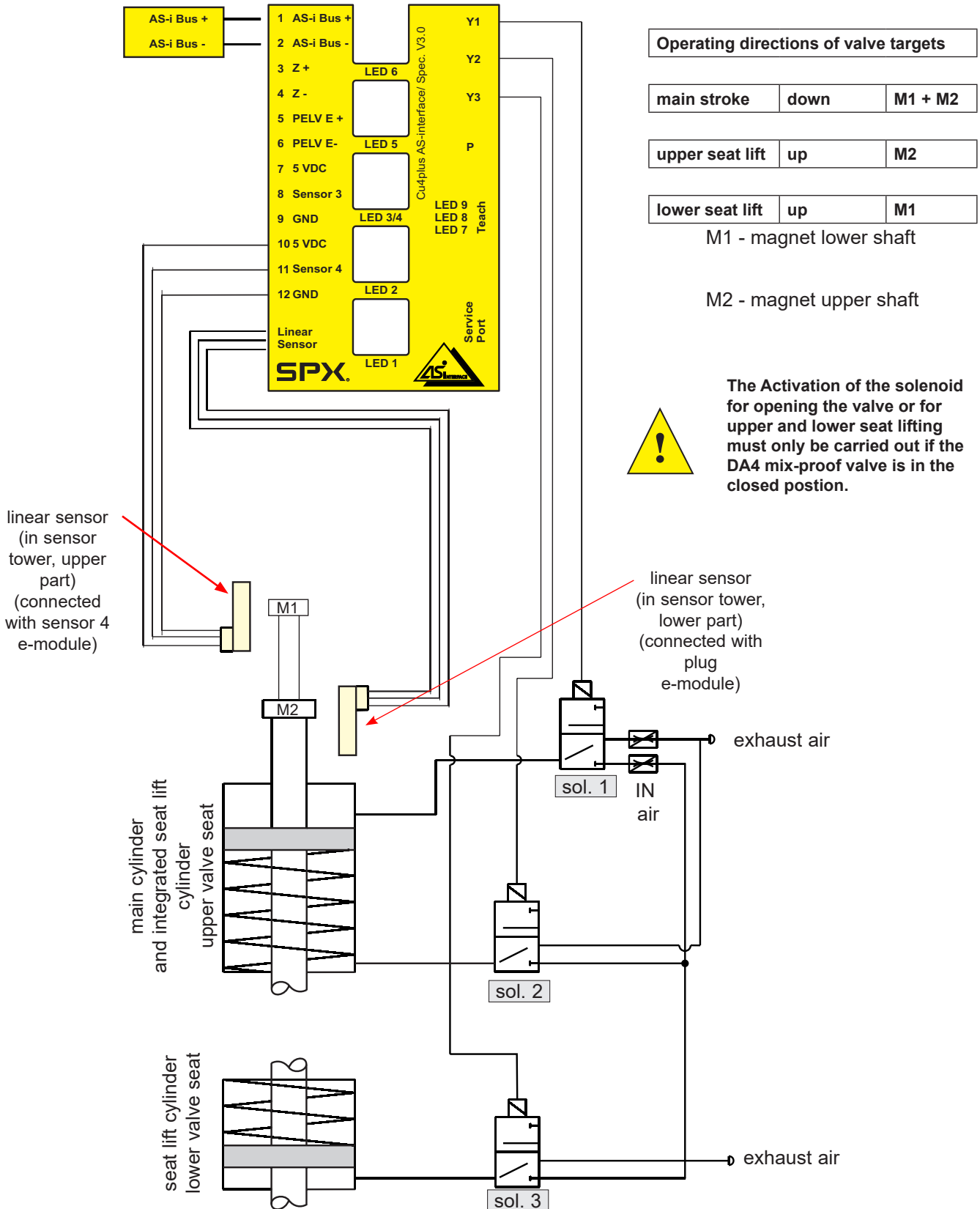

4. Mechanics and Pneumatics

4.4. Functional description - block diagrams

4.4.7. CU43plus-D4-V2 for DT4 SL double seat tank outlet valves

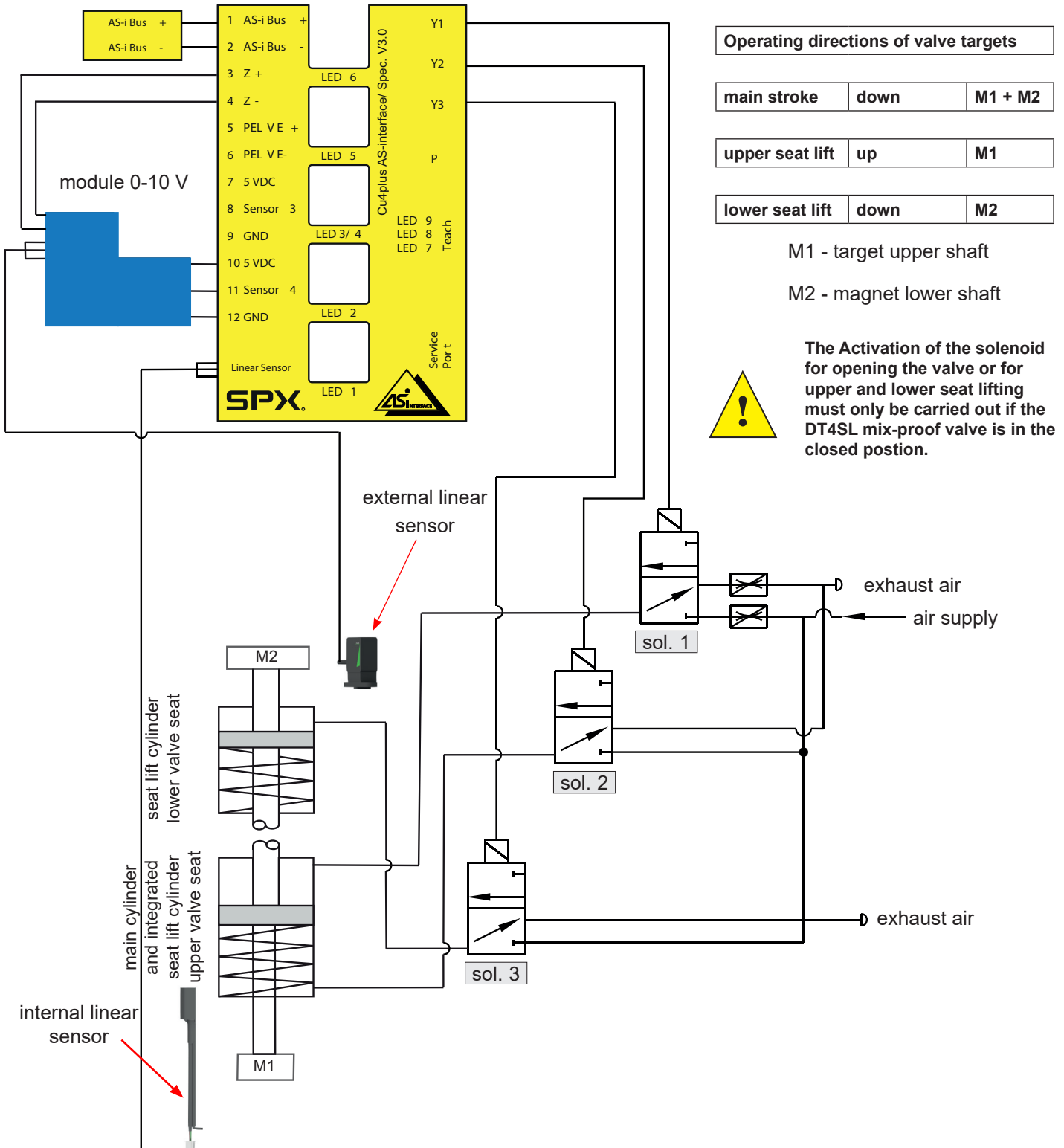

4. Mechanics and Pneumatics

4.4. Functional description - block diagrams

4.4.8. CU43plus-D4 for AM1 aseptic mixproof valves

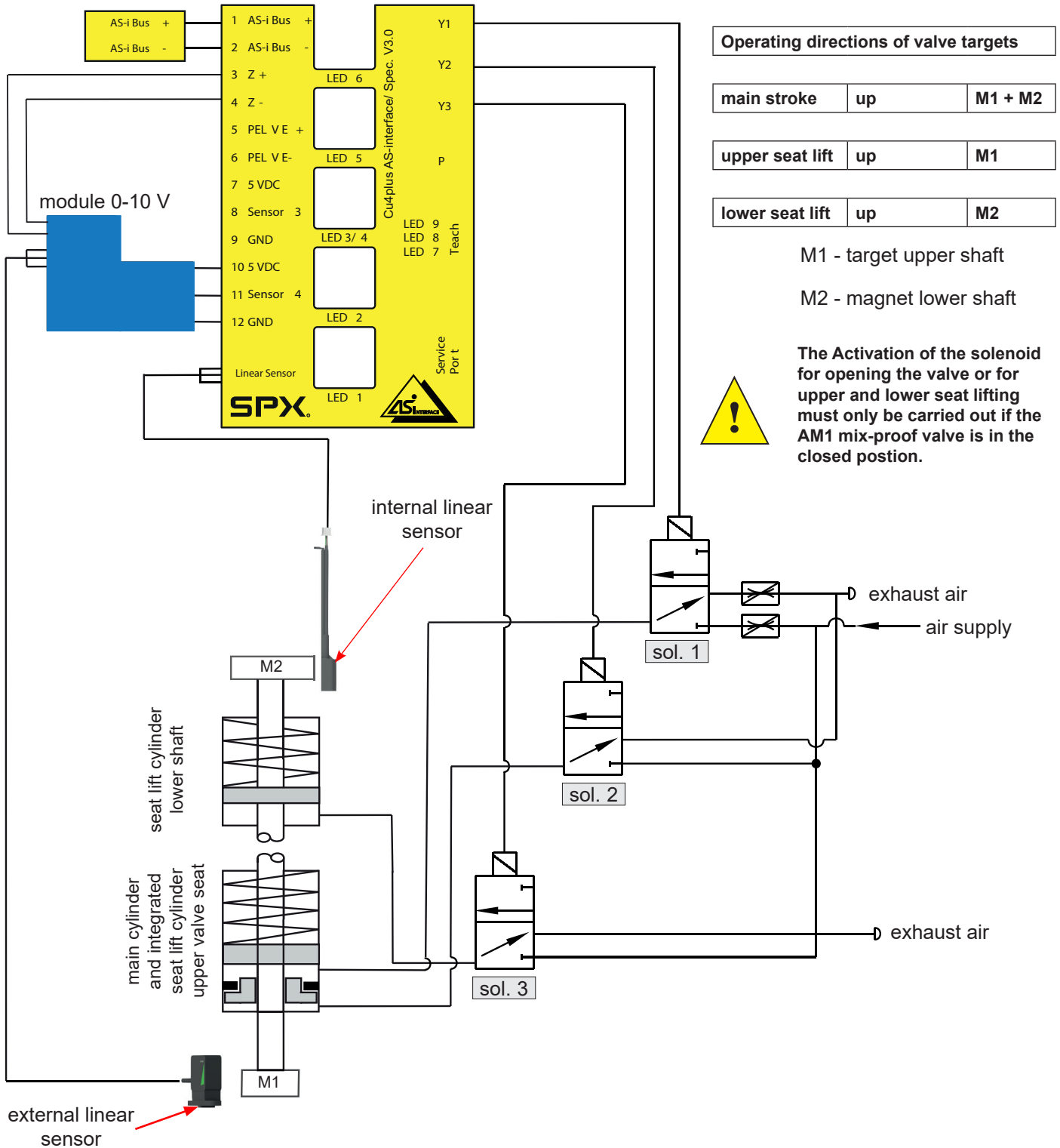

4. Mechanics and Pneumatics

4.5. Technical data / Standards

Material:	PA6.6/PA12
Ambient temperature:	-20 to +70 °C, -4 to +158 °F
EU:	EMC 2014/30/EU (89/336/EEC)

Standards and environmental audits:

protective class IP 67 EN 60529/
 complies with NEMA 6
 EMV interference resistance EN
 61000-6-2
 EMV emitted interference EN61000-6-4
 AS-interface certification according to
 specification V3.0

vibration/oscillation EN60068-2-6

safety of machinery DIN EN ISO
 13849-1

Air hose: 6 mm / ¼" OD

Pressure range: 6–8 bar

Compressed air quality: quality class acc. to DIN ISO 8573-1

- **content of solid particles:** quality class 3,
 max. size of solid particles per m³
 10000 of 0,5 µm < d < 1,0 µm
 500 of 1,0 µm < d < 5,0 µm
- **content of water:** quality class 3,
 max. dew point temperature -20 °C
 For installations at lower temperatures
 or at higher altitudes, additional
 measures must be considered to reduce
 the pressure dew point accordingly.
- **content of oil:** quality class 1,
 max. 0,01 mg/m³

The oil applied must be compatible with Polyurethane elastomer materials.

4. Mechanics and Pneumatics

4.6. Solenoid valves

In the base of the control unit max. 3 solenoid valves are installed. The 3/2-way solenoid valves are connected with the electronic module by moulded cables and plug connector.

control: PWM signal
handle: rotary switch at valve

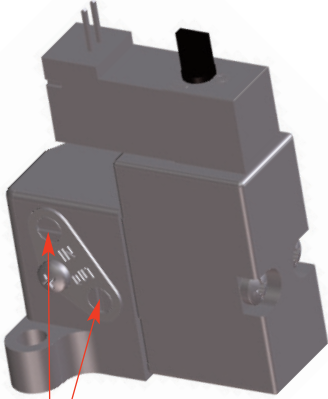

throttle screws

4.7. Throttling function

The operating speed of the valve actuator can be varied or reduced. This may be necessary to slacken the actuation of the valve in order to prevent pressure hammers in the piping installation. For this purpose, the supply and exhaust air of the **first solenoid valve** can be adjusted via the throttling screws respectively allocated in the interface of the solenoid valve. By turning the screws in anticlockwise direction, the inlet or outlet air is throttled.

4.8. NOT element

Through the installation of the logic NOT element, the closing force of the valve actuator can be increased by additional compressed air. The NOT element conveys the compressed air via an external reducing valve (max. 5 bar) to the spring side of the valve actuator.



The pressure reducing valve is fixed to 5 bar.

Note!

The air connection of the NOT element is equipped with an integrated non-return valve. The air hose must be slid into the air connection until it stops in order to open the non-return valve.

The NOT element is also used for air/air - actuators.

5. Adapter

Adapter for different process valves

5.1. Valves with turning actuator, e.g. butterfly valve

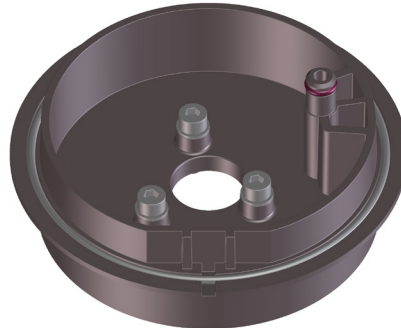

5.2. Single seat valve

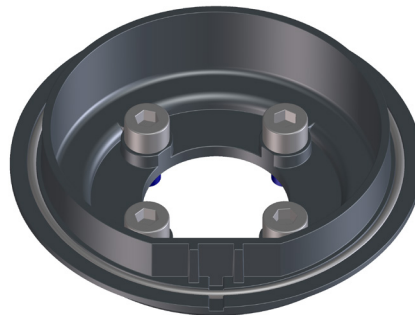

5.3. Double seat mix proof valve DE3, DA3+



5.4. Double seat mix proof valves D4, D4 SL, D4 PMO, DA4



5. Adapter

Adapter for different process valves

5.5. Double seat tank outlet valve DT4 SL and AM1 aseptic mixproof valve

5.5.1. DT4 - 62 adapter



5.5.2. DT4 - 92 adapter



6. Electronic Module

6.1. Function/block diagram

The CU4plus AS-i control unit is a slave for the fieldbus system AS-Interface according to specification V3.0. The profile is S-7.A.*.E (3 outputs and 2/4 inputs).

The CU4plus AS-i is designed for the extended address range. With these devices in the extended address range up to 62 slaves (formerly known as 2.1) can be connected with one AS-Interface cable.

Attention: Consider cumulative power input and simultaneity factor!

With the CU4plus AS-i energy supply of the control valves can be effected via the AS-i bus or via separate auxiliary energy lines. Thus, it is possible to realize an EMERGENCY STOP function: If the auxiliary voltage is safely shut off by conventional means, the control valves are deprived of electric energy and they fall into a safe position. The function of the inputs is preserved even if auxiliary energy is shut off.

The control of the solenoid valves is undertaken in energy-saving mode via the pwm signals.

6.1.1. CU43plus AS-i SLD

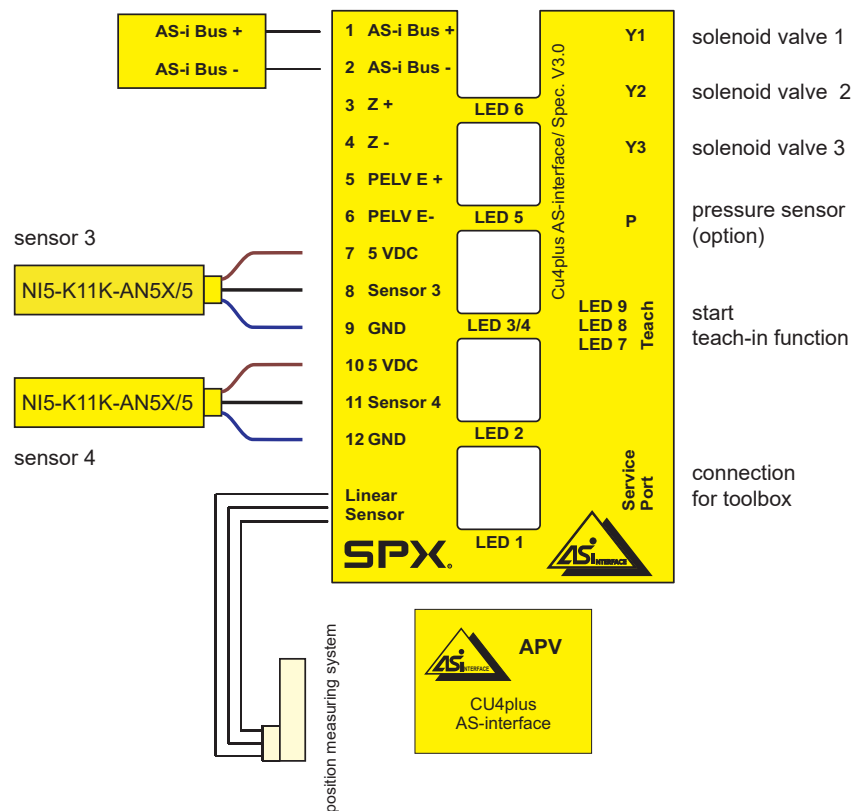

6. Electronic Module

6.1. Function/block diagram

6.1.2. CU41plus-D4-V1 CU43plus-D4-V1

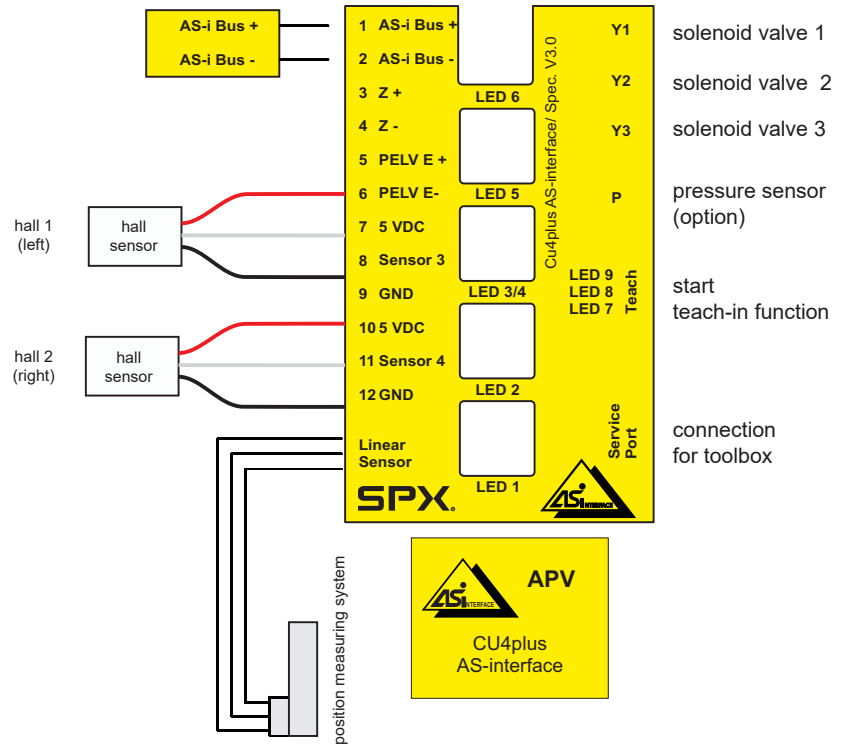

6.1.2. CU41plus-D4-V2 CU43plus-D4-V2

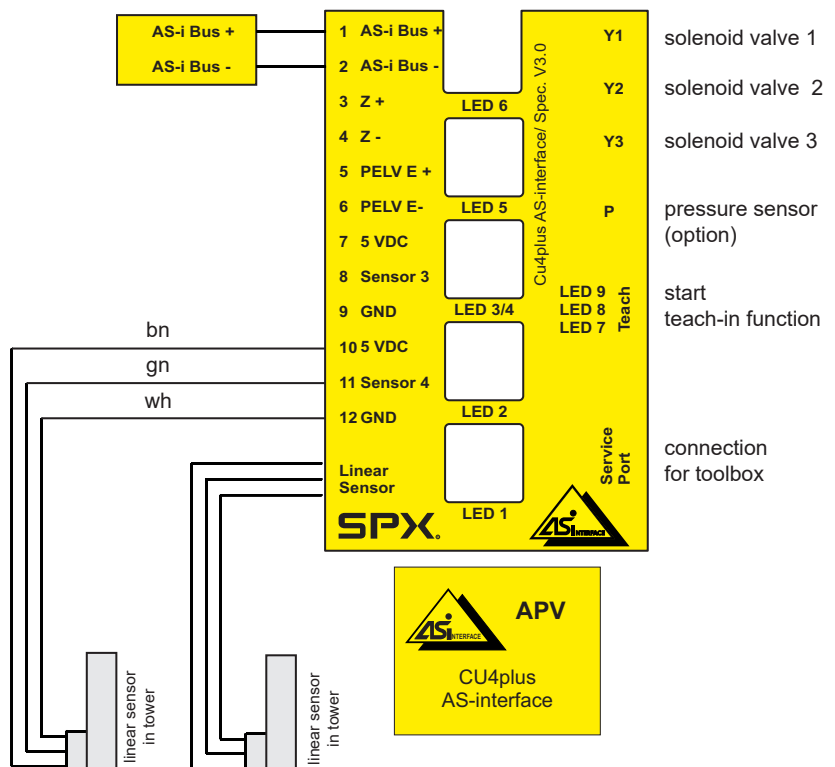

6. Electronic Module

6.1. Function/block diagram

6.1.3. CU43plus-DT4 / AM1

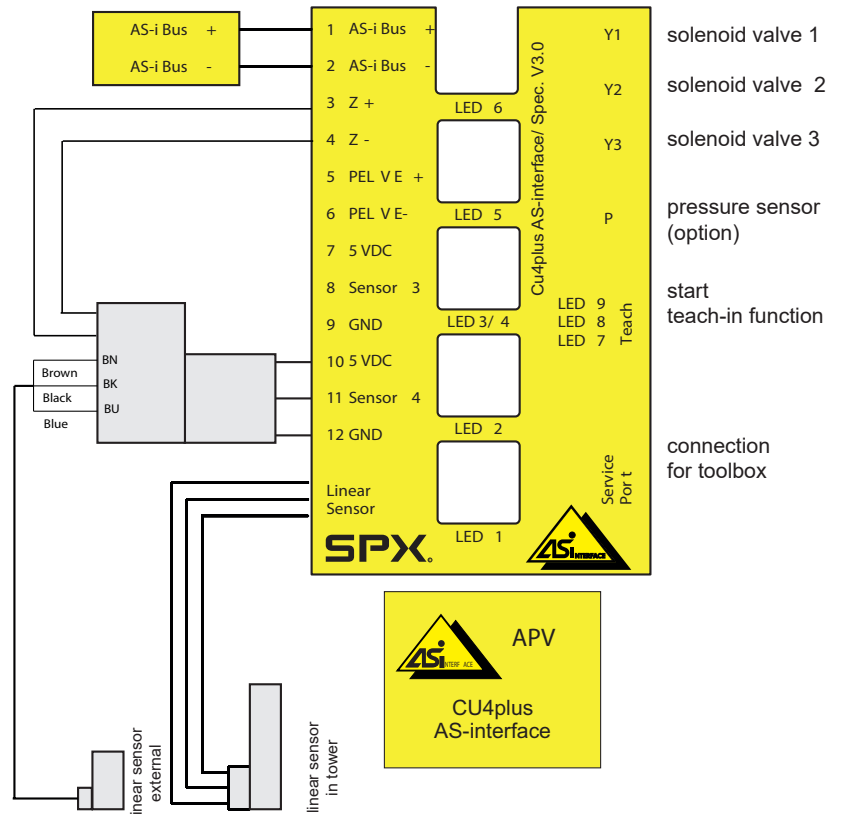

6. Electronic Module

6.1. Function/block diagram

6.1.4. Standard Function

Voltage supply of solenoid valves via AS-i bus

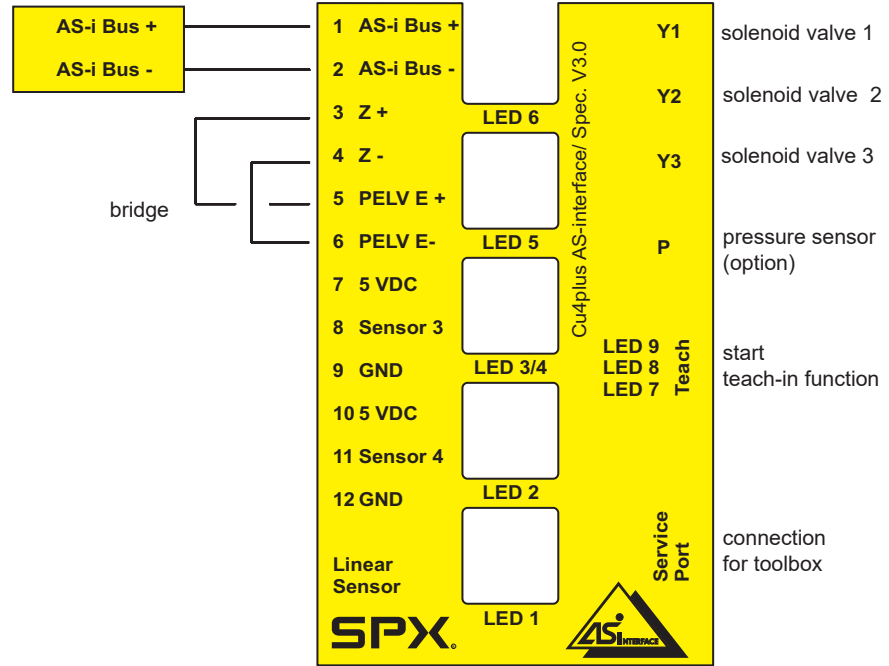

6.1.5. Safety Stop Function

Voltage supply of solenoid valves via additional auxiliary energy

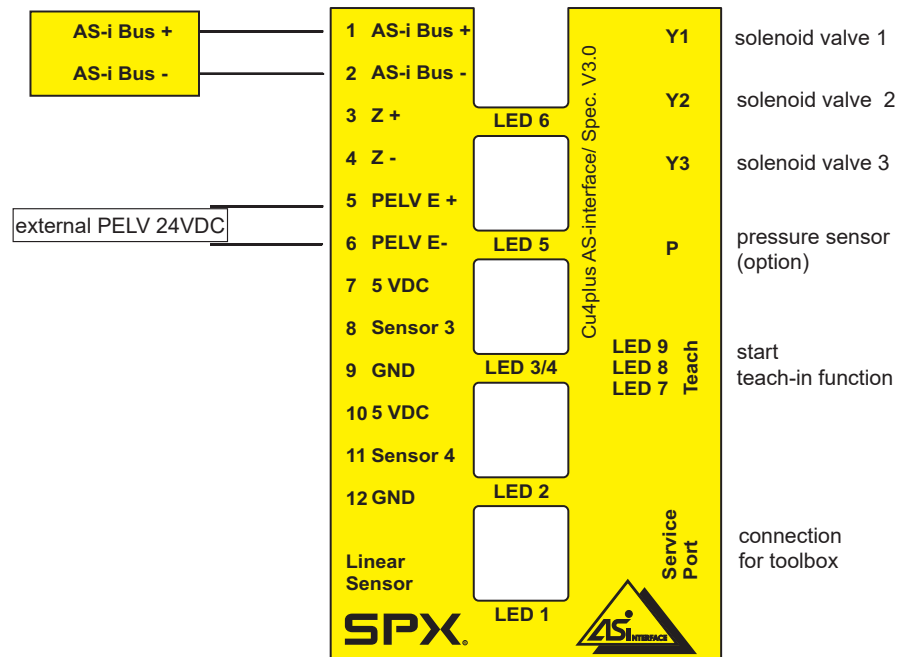

6. Electronic Module

6.2. Functional description of connections

6.2.1. Functional description of connections - Version V1

Terminal	Designation	Functional Description
1	AS-i +	connection AS-i network
2	AS-i -	connection AS-i network
3	Z +	bridge Z+ / PELV E+ (in case of energy supply for solenoid valves via AS-i bus)
4	Z -	bridge Z- / PELV E- (in case of energy supply for solenoid valves via AS-i bus)
5	PELV E+	separate auxiliary energy PELV 24VDC + (for EMERGENCY STOP function, only)
6	PELV E-	separate auxiliary energy PELV 24VDC - (for EMERGENCY STOP function, only)
7	5 VDC	voltage supply for proximity switches
8	Sensor 3	signal sensor 3 (evaluation of logic table for appropriate valve type)
9	GND	mass potential for sensor voltage supply
10	5 VDC	voltage supply for proximity switches
11	Sensor 4	signal sensor 4 (evaluation of logic table for appropriate valve type)
12	GND	mass potential for sensor voltage supply
linear sensor		linear sensor for valve position detection (for suitable SPX FLOW sensor, only!)
Y1		solenoid valve 1 (main valve)
Y2		solenoid valve 2 (upper seat lift)
Y3		solenoid valve 3 (lower seat lift)
P		optional connection - pressure sensor
service port		connection serial/USB converter for CU4plus toolbox software

6.2.2. Functional description of connections - Version V2

Terminal	Designation	Functional Description
1	AS-i +	connection AS-i network
2	AS-i -	connection AS-i network
3	Z +	bridge Z+ / PELV E+ (in case of energy supply for solenoid valves via AS-i bus)
4	Z -	bridge Z- / PELV E- (in case of energy supply for solenoid valves via AS-i bus)
5	PELV E+	separate auxiliary energy PELV 24VDC + (for EMERGENCY STOP function, only)
6	PELV E-	separate auxiliary energy PELV 24VDC - (for EMERGENCY STOP function, only)
7	5 VDC	voltage supply for proximity switches
8	no sensor	
9	GND	mass potential for sensor voltage supply
10	5 VDC	voltage supply for proximity switches
11	sensor 4	linear sensor for valve position detection (for suitable SPX FLOW sensor, only!)
12	GND	mass potential for sensor voltage supply
linear sensor		linear sensor for valve position detection (for suitable SPX FLOW sensor, only!)
Y1		solenoid valve 1 (main valve)
Y2		solenoid valve 2 (upper seat lift)
Y3		solenoid valve 3 (lower seat lift)
P		optional connection - pressure sensor
service port		connection serial/USB converter for CU4plus toolbox software

6. Electronic Module

6.3. Technical data / AS-interface

AS-interface-profile:	S-7.A.*.E
Extended address mode:	is supported
Serial communication mode:	no
Inverse-polarity protection:	exists
Indication "Power":	LED 3 (green)
Indication "Fault":	LED 4 (red)
AS-interface voltage range:	26.5...31.6 V
External voltage supply	
PELV	24 VDC
max. current consumption:	100 mA
(in case of supply of actuators from auxiliary energy)	150 mA
(in case of supply of actuators from AS-interface)	
Input delay time:	< 1 s
AS-interface specification:	V3.0
Supply of solenoid valves:	pwm signal from electronic module
Short-circuit protection:	yes
Excess voltage protection:	100 mA
Induction protection:	yes
Status indication of outputs:	LED on board
Response time of watchdog:	--- (watchdog not activated)

Short-circuit or excess voltage of actuator supply or cable break at valves is signalled to the master via the peripheral failure bit (profile S-7.A.*.E only). Simultaneously, LED 3/4 flashes according to AS-interface specification alternately red/green.

Supply of sensors: 5 VDC, 4,75...5,25V (sum of all currents < 40mA)



Caution!

The sensor inputs and the peripheral supply must not be connected with installation-GND.

Connecting terminals: conductor cross section 0.5 – 1,5 mm² (with conductor sleeve) complying with AWG 20-16

AS-interface communication / data: see 6.7.

6. Electronic Module

6.4. Connections

Sensors for valve position detection:

Internal sensors: internal linear sensor SPX FLOW type switching distance acc. to SPX FLOW specification

Internal hall sensors: "magnetic hall sensor"
SPX FLOW UB 4.75 - 5.25 VDC
switching distance acc. to SPX FLOW specification







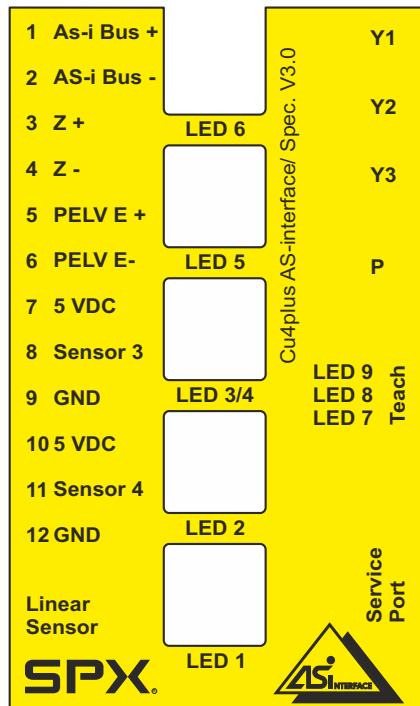





External sensors: inductive proximity switch
SPX FLOW UB 4.75-5.25 VDC
switching distance acc. to SPX FLOW specification

6.5. LED indications

The meanings of the different colors of the LED indication are described in table 6.5.1. LED indications / Indicator lights.



6. Electronic Module

6.5.1. LED indication / Indicator lights				
LED 1	solenoid valve 2 / upper seat lift	blue, 1 blink		solenoid valve 2 controlled upper seat * lifted
	solenoid valve 3 / lower seat lift	blue, 2 blinks		solenoid valve 3 controlled lower seat * lifted
LED 2	sol. valve 1 /main valve	blue, 2 blinks		main valve controlled
LED 3/4	power and diagnosis	green, permanent light		operating voltage ok, no failure - AS-i status indication
		red, green blink		peripheral failure (short circuit, excess voltage, cable break) - teach-in requested, flash data failure, valve failure, wrong number of valves, overload of sensor voltage supply
		red, permanent light		AS-i communication failure - no data interchange with master - master in stop mode - slave cannot read master commands - master in protect mode and slave not in protect mode
		green, blink		AUX voltag missing (connect either PELV or bridge Z/PELV)
		green, permanent light red, blink = red-yellow blink		slave address = 0
		red, blink		duplicate addresses recognized
LED 5	valve closed	orange, permanent light		valve closed
LED 6	valve open	green, permanent light		valve open
LED 7	pressure signal (option)			
LED 8	service request	yellow, permanent light		imminent service request
LED 9	teach-in	red, permanent light blink		teach-in is running teach-in required
LED Y1	solenoid valve 1	permanent light		controlled
LED Y2	solenoid valve 1	permanent light		controlled
LED Y3	solenoid valve 1	permanent light		controlled

*** Depending on the adjusted mode!**

6. Electronic Module

6.6. Adjustment of valve profiles

The adjustment of valve profiles is carried out with the Service Software CU4plus Toolbox (see CU4plus Toolbox manual). For the different process valves different logic profiles exist. These differ in view of the detection of the feedback and the logic profile of the valve.

Valve profile:

Type	Valve profile	Valve position measuring system	Tolerance band	Valve basic position NO/NC	Invert - valve position indication	Number of solenoids
0	V2 - Mix proof valve DA4	2 internal linear sensors	fixed +/- 1 mm	NC only	possible	always 3
1	V2 - Mix proof valve D4	2 internal linear sensors	fixed +/- 1 mm	NC only	possible	always 1
2	V2 - Mix proof valve D4 SL	2 internal linear sensors	fixed +/- 1 mm	NC only	possible	always 3
3	V1 - Mix proof valve DA4	internal linear sensor and 2 hall sensors	fixed +/- 1 mm	NC only	possible	always 3
4	V1 - Mix proof valve D4	internal linear sensor and 1 hall sensor	fixed +/- 1 mm	NC only	possible	always 1
5	V1 - Mix proof valve D4 SL	internal linear sensor and 2 hall sensors	fixed +/- 1 mm	NC only	possible	always 3
6	Mix proof valve with seat lift detection (DA3+ SLD)	internal linear sensor and 2 external proximity switches	fixed +/- 1 mm	NC only	possible	always 3
7	Mix proof valve with seat lift detection (DA3+ SLD) CU3 compatibility mode	internal linear sensor and 2 external proximity switches	fixed +/- 1 mm	NC only	possible	always 3
8	Mix proof / seat valve with external feedback detection	external proximity switches	not available	NC / NO	possible	optional 1,2,3
9	Seat valve / butterfly valve with internal feedback detection	internal linear sensor	+/- 1 mm +/- 3 mm +/- 5 mm	NC / NO	possible	optional 1,2,3
A	Double seat tank outlet valve DT4 SL	1 internal linear sensor 1 external linear sensor	fixed +/- 1 mm	NC only	not possible	always 3
B	V2 - Mix proof valve D4 PMO	2 internal linear sensors	fixed +/- 1 mm	NC only	possible	always 3
C	Aseptic mix-proof valve AM1	1 internal linear sensor 1 external linear sensor	fixed	NC only	not possible	always 3
D	Mix proof valve D4SL and DA4	2 internal linear sensors	+/- 1 mm	NC only	possible	always 3

Valve basic position:
position can be adjusted.

Depending on the valve type, the basic

Tolerance band:

Selection according to valve type.
(see chapter 7.2)

Valve position indication:

LED can be inverted, e.g. for
adaption of valve type

Delivery status:
(SLD) profile is adjusted.

Mix proof valve with seat lift detection

AS-i address:
Adjusted valve characteristics:
with SLD

0 LED 4 (red) ON
logic profile 1, for DA3+

Teach-In:

CU waits for teach-in with valve, LED 3-6 blink

Adjustment / change of valve profile is realized via ToolBox software (see Toolbox manual).

6. Electronic Module

6.7. AS-i communication / Data signals

6.7.1. Single seat butterfly valves with internal feedback detection, valve profile type 9

NC - normally closed			
Application: single seat / butterfly valve with internal feedback detection (SW4, SD4, MS4, SVS, SV etc.)			
AS-i Communication Input Data / IDI	valve state	sensor 1	sensor 2
		signal generated by teach-in (position of position sensor)	signal generated by teach-in (position of position sensor)
DI0	closed	1	0
DI1	open	0	1
DI2	not occupied	1	1
DI3	not occupied	1	1
AS-i Communication Output Data / ODI	solenoid 1 Main	solenoid 2	solenoid 3
DO0	1	0	0
DO1	0	1	0
DO2	0	0	1
DO3	not occupied	not occupied	not occupied
NO - normally open			
Application: single seat / butterfly valve with internal feedback detection (SW4, SD4, MS4, SVS, SV etc.)			
AS-i Communication Input Data / IDI	valve state	sensor 1	sensor 2
		signal generated by teach-in (position of position sensor)	signal generated by teach-in (position of position sensor)
DI0	closed	0	1
DI1	open	1	0
DI2	not occupied	1	1
DI3	not occupied	1	1
AS-i Communication Output Data / ODI	solenoid 1 Main	solenoid 2	solenoid 3
DO0	1	0	0
DO1	0	1	0
DO2	0	0	1
DO3	not occupied	not occupied	not occupied

6. Electronic Module

6.7. AS-i communication / Data signals

6.7.2. Mix proof valve with seat lift detection (DA3+ SLD), valve profil type 6

NC - normally closed					
Application: Double seat mix proof valve with seat lift detection (SLD)					
AS-i Communication Input Data / IDI	valve state	sensor 4	sensor 3	sensor 2	sensor 1
		external proximity switch	external proximity switch	signal generated by teach-in, (position of position sensor)	signal generated by teach-in, (position of position sensor)
DI0	closed	1	1	0	1
DI1	open	0	0	1	0
DI2	upper seat lifting	0	1	0	1
DI3	lower seat lifting	1	1	0	0

The appropriate AS-i signal for valve position will be generated within the CU by logic combination of the 4 sensor signals. The appropriate valve position is shown direct by the IDI AS-i signals. Further adjustments are not required!

AS-i Communication Output Data / ODI	solenoid 1 main	solenoid 2 upper seat lift	solenoid 3 lower seat lift
DO0	1	0	0
DO1	0	1	0
DO2	0	0	1
DO3	not occupied	not occupied	not occupied

When replacing a CU3 control unit, use the following profile:
 Double seat mix proof valve with seat lift detection (SLD) CU3 compatible mode
 (all signals similar to CU3) - see instruction manual of CU3 Control Unit.

6. Electronic Module

6.7. AS-i communication / Data signals

6.7.3. Mix proof valve D4 - V1, valve profil type 4

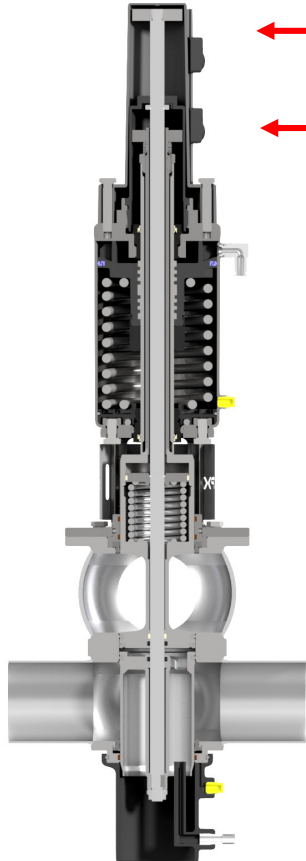

operating	main stroke downwards		
-----------	-----------------------	--	--

main stroke	valve operating direction: downwards		
-------------	--------------------------------------	--	--

lower shaft	signal S3 signal S4	internal hall sensors	valve target M1
-------------	------------------------	-----------------------	--------------------

upper shaft	signal S2 signal S1	linear sensor	valve target M2
-------------	------------------------	---------------	--------------------

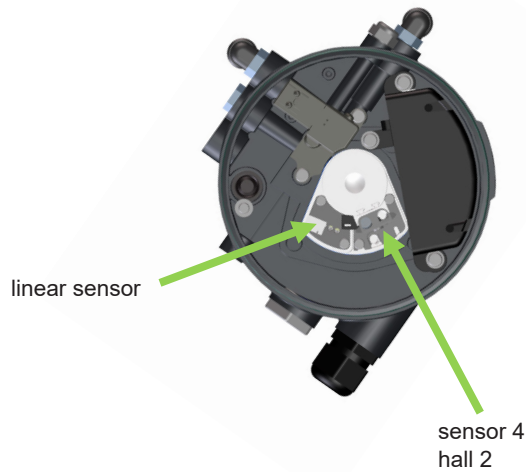

AS-i input data	valve status	linear sensor / (teach data)		internal hall sensors		tolerance band
		sensor signal S1			sensor signal S4	
DI0	closed	1			0	+1 mm, -1 mm
DI1	open	0			1	+1 mm, -1 mm

AS-i output data	solenoid 1 Main		
DO0	1		

6. Electronic Module

6.7. AS-i communication / Data signals

6.7.3. Mix proof valve D4 - V2, valve profil type 1

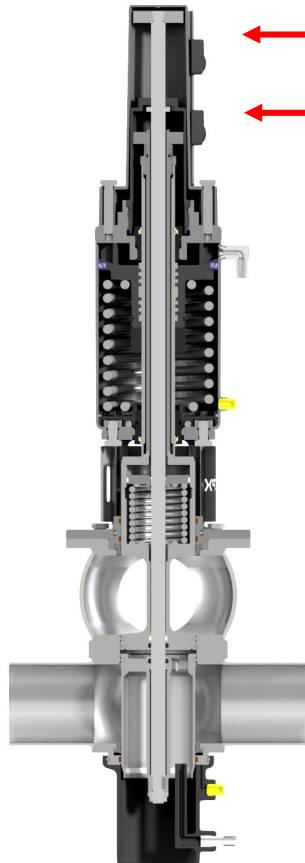

operating	main stroke downwards	
-----------	-----------------------	--

main stroke	valve operating direction: downwards	
-------------	--------------------------------------	--

lower shaft	signal S3 signal S4	linear sensor 1	valve target M1
-------------	------------------------	-----------------	--------------------

upper shaft	signal S2 signal S1	linear sensor 2	valve target M2
-------------	------------------------	-----------------	--------------------

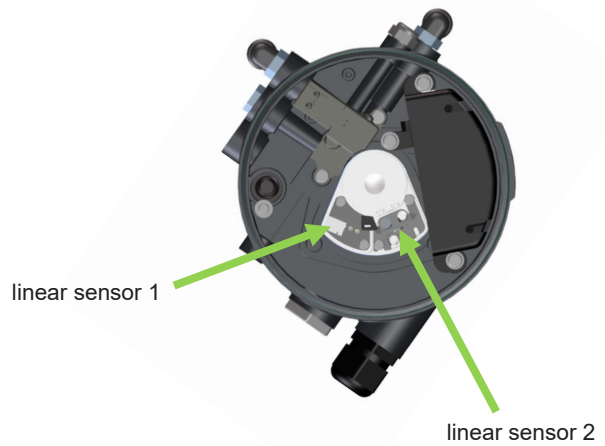

AS-i input data	valve status	linear sensor 2 / (teach data)		linear sensor 1 / (teach data)		tolerance band
		sensor signal S1			sensor signal S4	
D10	closed	1			0	+1 mm, -1 mm
D11	open	0			1	+1 mm, -1 mm

AS-i output data	solenoid 1 Main		
DO0	1		

6. Electronic Module

6.7. AS-i communication / Data signals

6.7.4. Mix proof valve D4 SL - V1, valve profil type 5

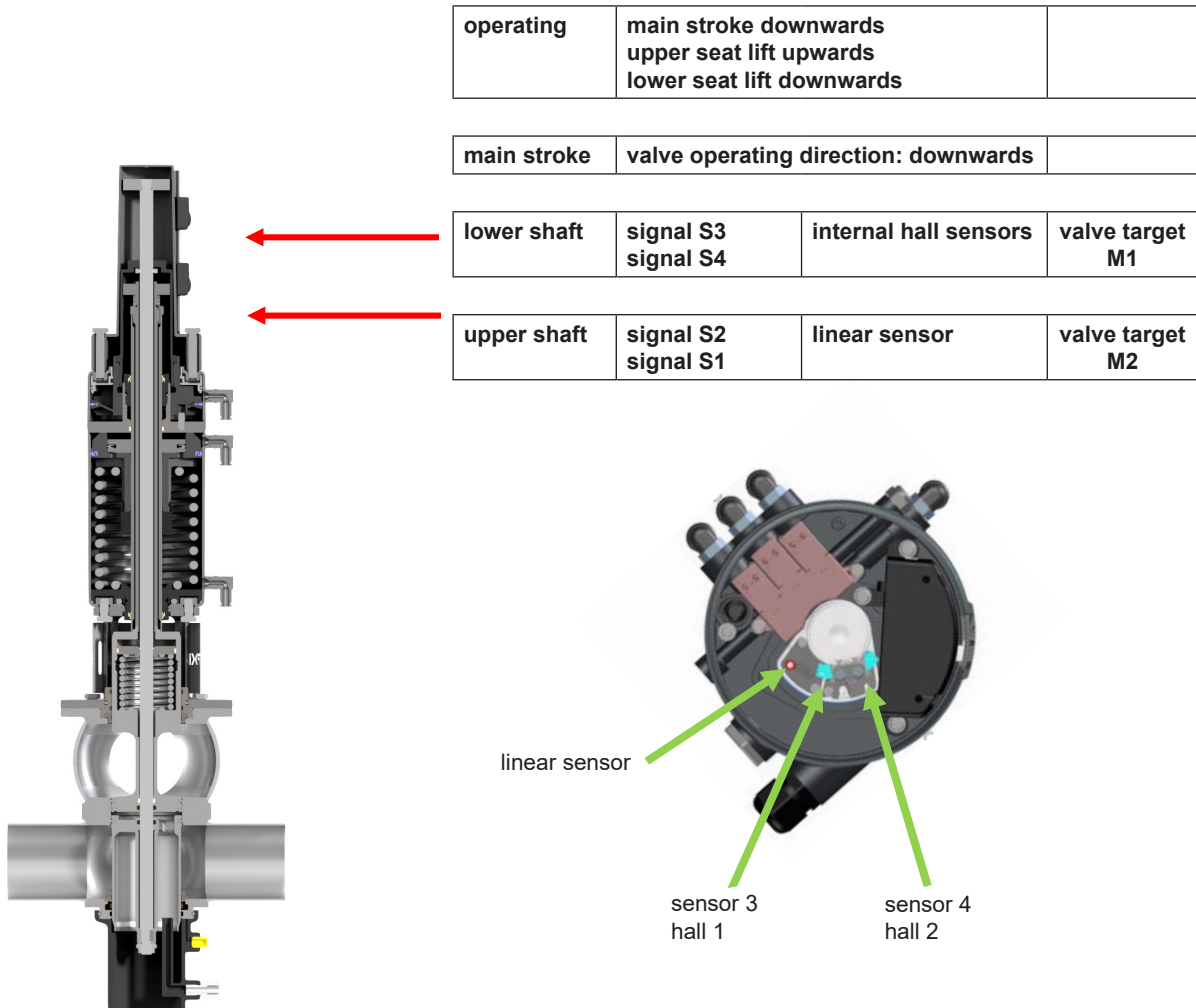

AS-i input data	valve status	linear sensor / (teach data)		internal hall sensors		tolerance band
		sensor signal S1	sensor signal S2	sensor signal S3	sensor signal S4	
DI0	closed	1	0	1	0	+1 mm, -1 mm
DI1	open	0	0	0	1	+1 mm, -1 mm
DI2	upper seat lift	0	1	1	0	+1 mm, -1 mm
DI3	lower seat lift	1	0	0	0	+1 mm, -1 mm

AS-i output data	solenoid 1 Main	solenoid 2 upper seat lift	solenoid 3 lower seat lift
DO0	1	0	0
DO1	0	1	0
DO2	0	0	1

6. Electronic Module

6.7. AS-i communication / Data signals

6.7.4. Mix proof valve D4 SL - V2, valve profile type 2

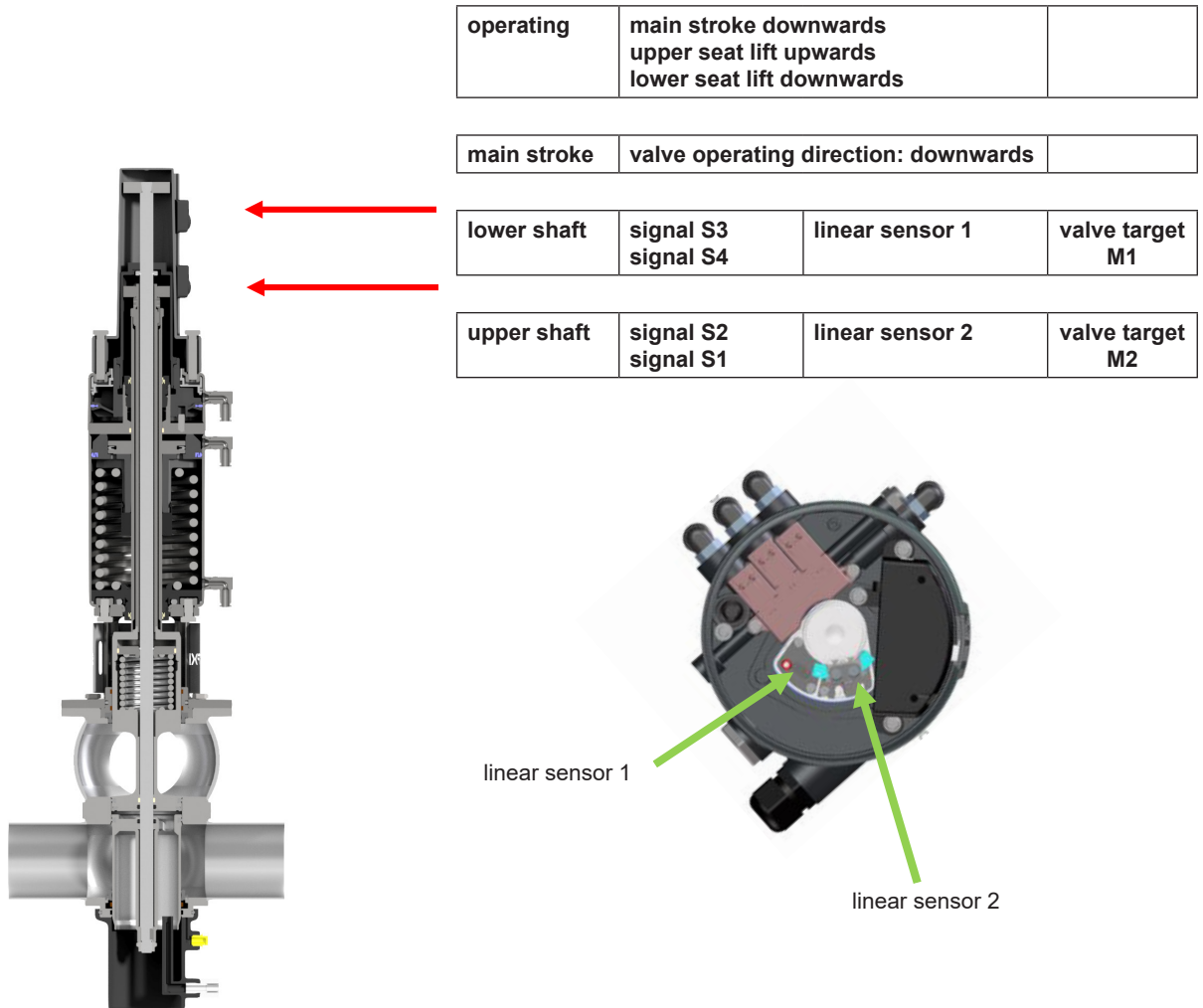

AS-i input data	valve status	linear sensor 2 / (teach data)		linear sensor 1 / (teach data)		tolerance band
		sensor signal S1	sensor signal S2	sensor signal S3	sensor signal S4	
DI0	closed	1	0	1	0	+1 mm, -1 mm
DI1	open	0	0	0	1	+1 mm, -1 mm
DI2	upper seat lift	0	1	1	0	+1 mm, -1 mm
DI3	lower seat lift	1	0	0	0	+1 mm, -1 mm

AS-i output data	solenoid 1 Main	solenoid 2 upper seat lift	solenoid 3 lower seat lift
DO0	1	0	0
DO1	0	1	0
DO2	0	0	1

6. Electronic Module

6.7. AS-i communication / Data signals

6.7.5. Mix proof valve D4 PMO - V2, valve profile type B

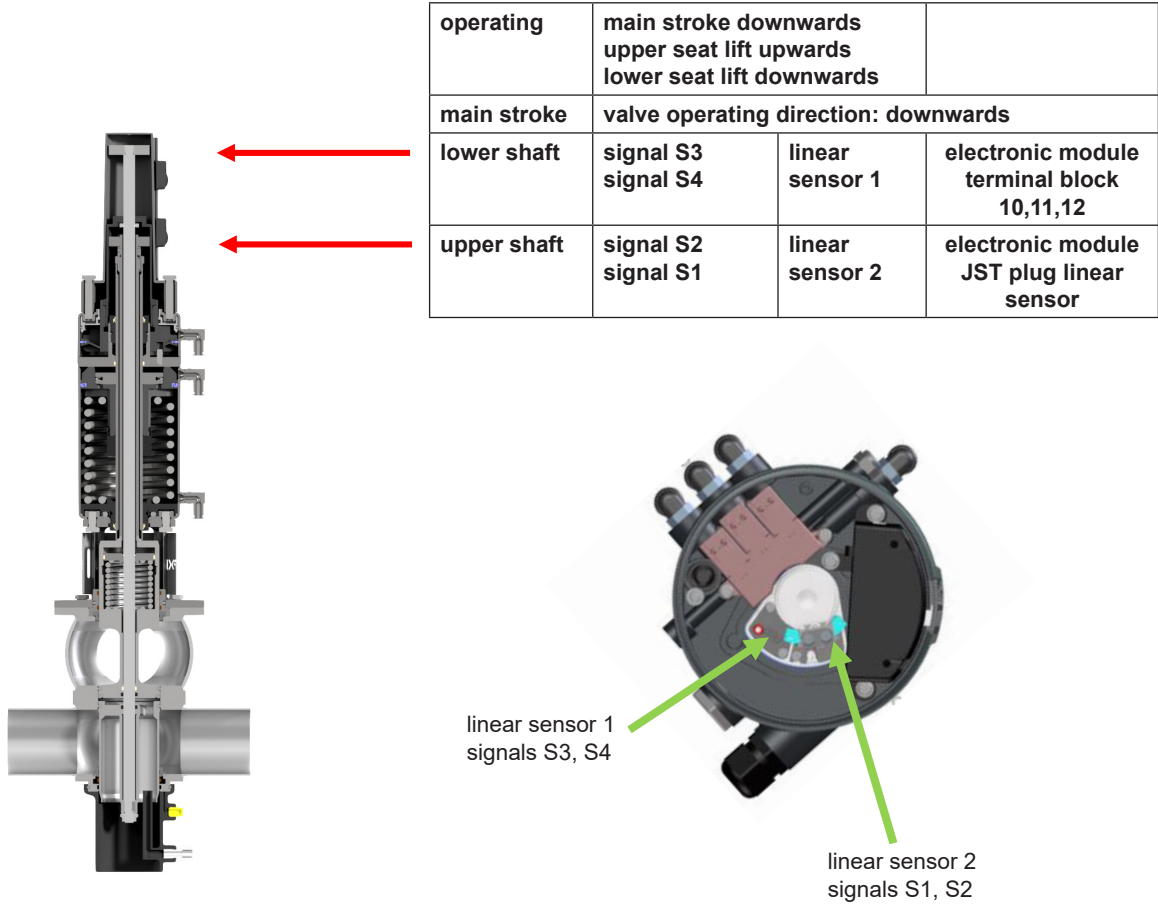

	valve status	linear sensor 2 / (teach data)		linear sensor 1 / (teach data)		tolerance band
		sensor signal S1	sensor signal S2	sensor signal S3	sensor signal S4	
	closed	1	0	1	0	+1 mm, -1 mm
	open	0	0	0	1	+1 mm, -1 mm
	upper seat lift	0	1	1	0	+1 mm, -1 mm
	lower seat lift	1	0	0	0	+1 mm, -1 mm

AS-i input data	DI0	DI1	DI2	DI3
no logical combination of sensor signals, just raw data combination table has to be implemented in PLC software during seat lift - the opposite valve shaft stays in closed position, this can be monitored by watching the appropriate signal				

AS-i output data	solenoid 1 Main	solenoid 2 upper seat lift	solenoid 3 lower seat lift
DO0	1	0	0
DO1	0	1	0
DO2	0	0	1

6. Electronic Module

6.7. AS-i communication / Data signals

6.7.6. Mix proof valve DA4 - V1, valve profile type 3

operating	main stroke downwards upper seat lift upwards lower seat lift upwards	
-----------	---	--

main stroke	valve operating direction: downwards	
-------------	--------------------------------------	--

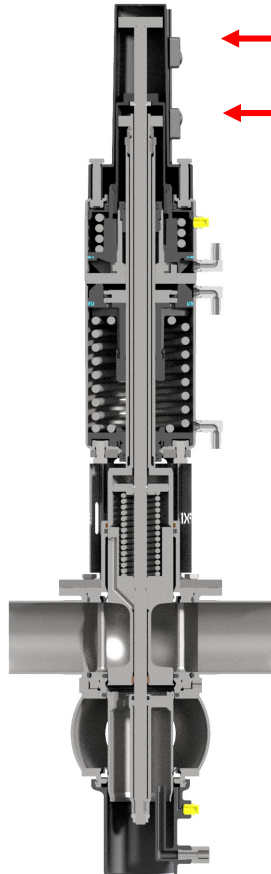

lower shaft	signal S3 signal S4	internal hall sensors	valve target M1
upper shaft	signal S2 signal S1	linear sensor	valve target M2

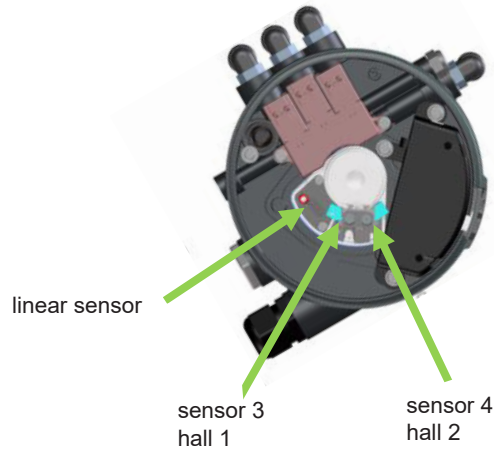

AS-i input data	valve status	linear sensor / (teach data)		internal hall sensors		tolerance band
		sensor signal S1	sensor signal S2	sensor signal S3	sensor signal S4	
DI0	closed	1	0	0	0	+1 mm, -1 mm
DI1	open	0	0	0	1	+1 mm, -1 mm
DI2	upper seat lift	0	1	0	0	+1 mm, -1 mm
DI3	lower seat lift	1	0	1	0	+1 mm, -1 mm

AS-i output data	solenoid 1 Main	solenoid 2 upper seat lift	solenoid 3 lower seat lift
DO0	1	0	0
DO1	0	1	0
DO2	0	0	1

6. Electronic Module

6.7. AS-i communication / Data signals

6.7.6. Mix proof valve DA4 - V2, valve profile type 0

operating	main stroke downwards upper seat lift upwards lower seat lift upwards	
-----------	---	--

main stroke	valve operating direction: downwards	
-------------	--------------------------------------	--

lower shaft	signal S3 signal S4	linear sensor 1	valve target M1
-------------	------------------------	-----------------	--------------------

upper shaft	signal S2 signal S1	linear sensor 2	valve target M2
-------------	------------------------	-----------------	--------------------

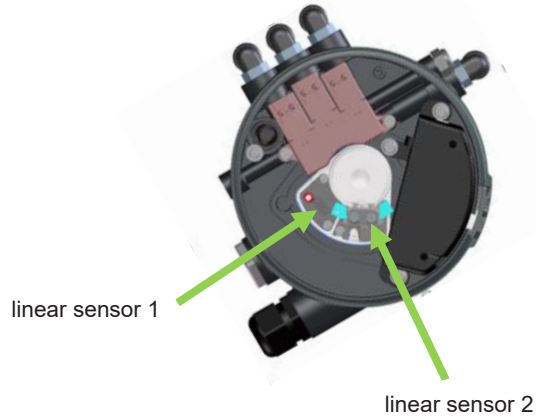
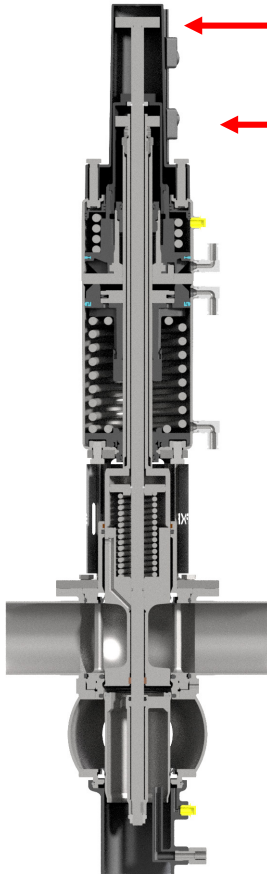

AS-i input data	valve status	linear sensor 2 / (teach data)		linear sensor 1 / (teach data)		tolerance band
		sensor signal S1	sensor signal S2	sensor signal S3	sensor signal S4	
DI0	closed	1	0	0	0	+1 mm, -1 mm
DI1	open	0	0	0	1	+1 mm, -1 mm
DI2	upper seat lift	0	1	0	0	+1 mm, -1 mm
DI3	lower seat lift	1	0	1	0	+1 mm, -1 mm

AS-i output data	solenoid 1 Main	solenoid 2 upper seat lift	solenoid 3 lower seat lift
DO0	1	0	0
DO1	0	1	0
DO2	0	0	1

6. Electronic Module

6.7. AS-i communication / Data signals

6.7.7. Double seat tank outlet valve DT4 SL - V2, valve profile type A

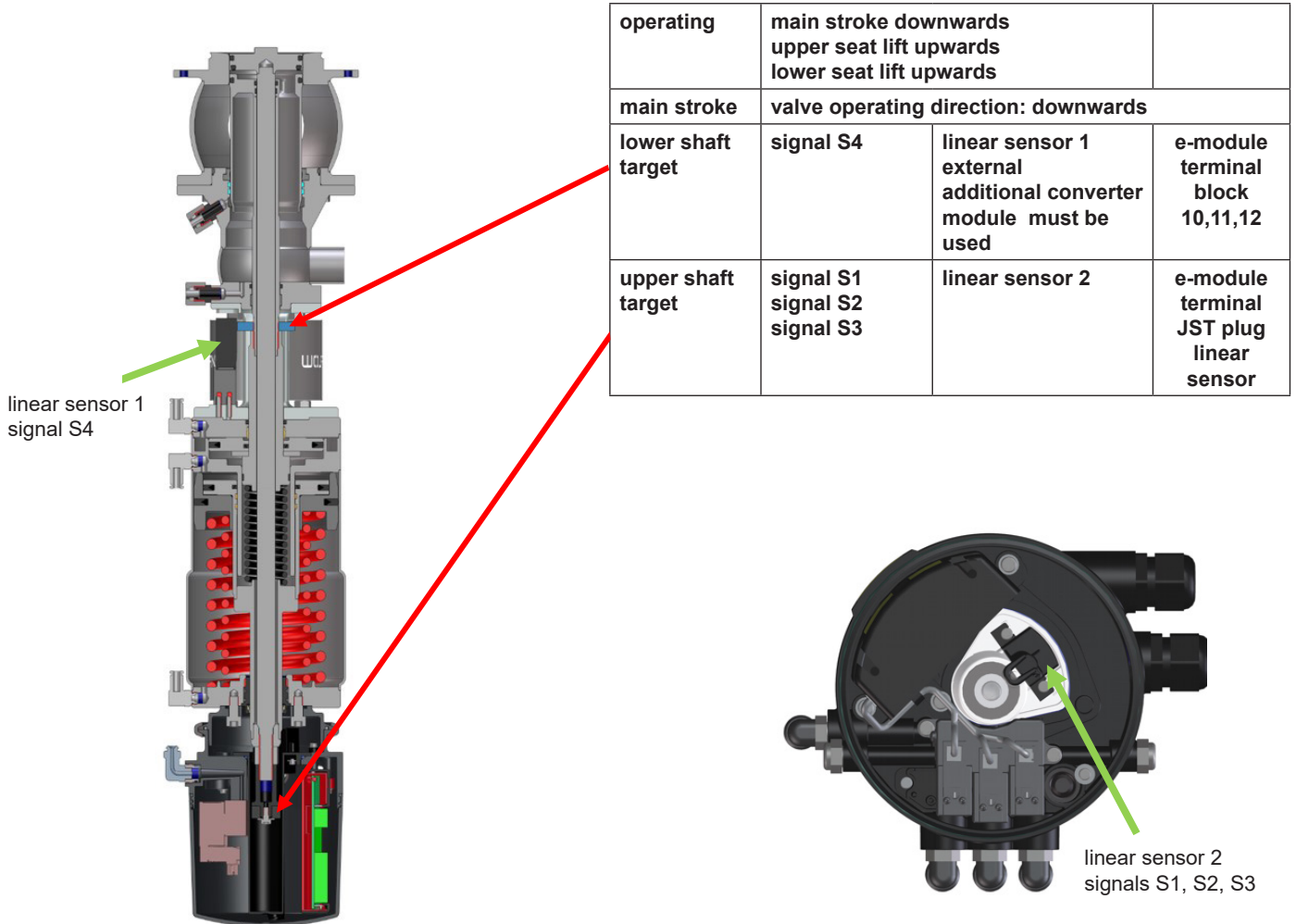

AS-i input data	valve status	linear sensor 2 / (Teach data)			linear sensor 1 / (Teach data)	tolerance band
		sensor signal S1	sensor signal S2	sensor signal lift	sensor signal S4	
DI0	closed	1	0	0	0	+1 mm, -1 mm
DI1	open	0	1	0	0	+1 mm, -1 mm
DI2	upper seat lift	0	0	1	0	+1 mm, -1 mm
DI3	lower seat lift	1	0	0	1	+1 mm, -1 mm

AS-i output data	solenoid 1 Main	solenoid 1 upper seat lift	solenoid 1 lower seat lift
DO0	1	0	0
DO1	0	1	0
DO2	0	0	1

6. Electronic Module

6.7. AS-i communication / Data signals

6.7.8. Aseptic mix proof valve AM1, valve profile type C

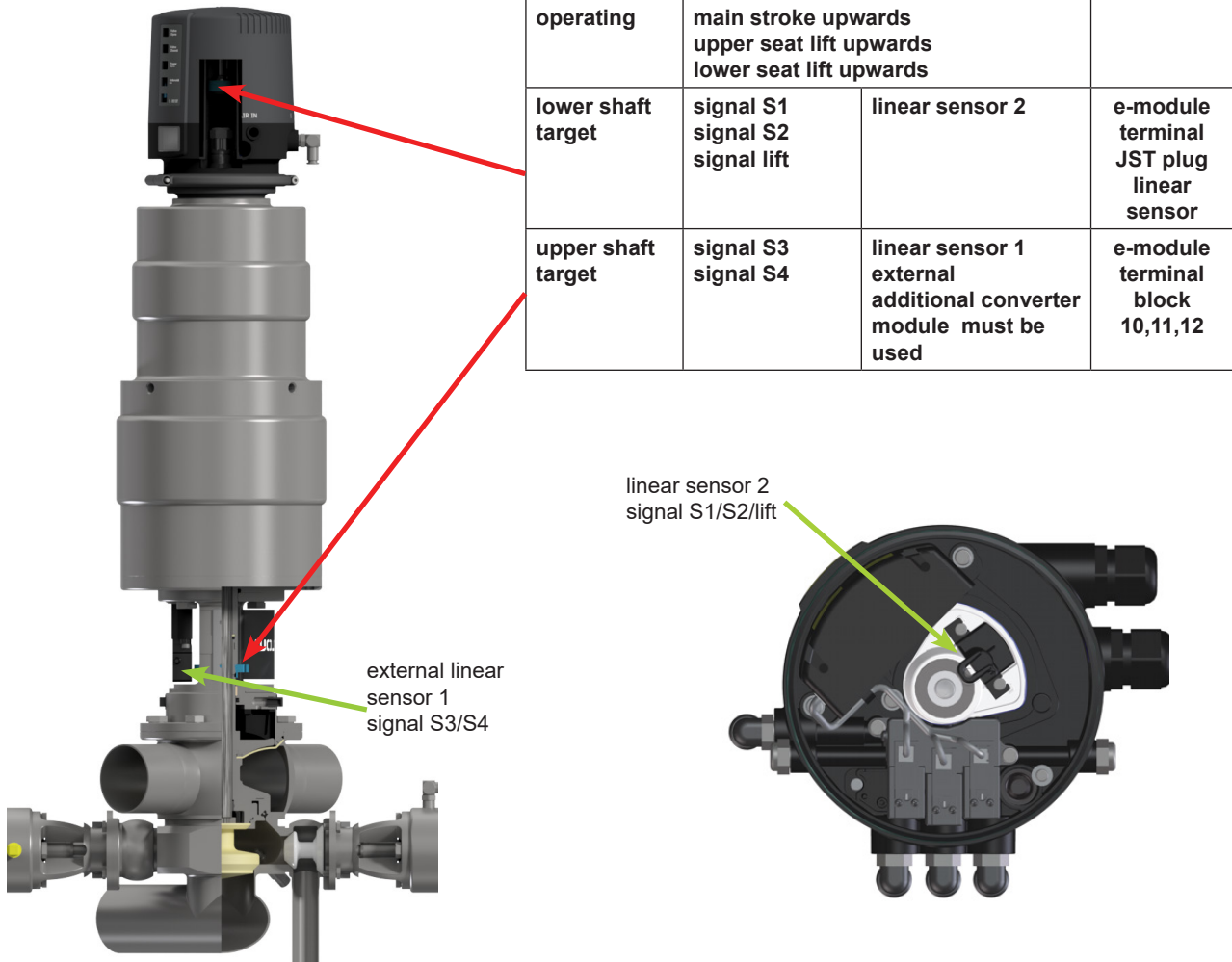

AS-i input data	valve status	External linear sensor 1 (S) / (Teach data)		Internal linear sensor 2 (J) / (Teach data)			
		signal S3	signal S4	signal S1	signal S2	lift	Tolerance band
DI0	closed	0	1	1	0	0	fixed
DI1	open	0	0	0	1	0	+/- 1mm
DI2	upper seat lift	1	0	1	0	0	fixed
DI3	lower seat lift	0	1	0	0	1	fixed

AS-i output data	solenoid 1 Main	solenoid 2 upper seat lift	solenoid 3 lower seat lift
DO0	1	0	0
DO1	0	1	0
DO2	0	0	1

6. Electronic Module

6.7. AS-i communication / Data signals

6.7.9. Valve profile type D

DA4 Mix proof valve	
operating	main stroke downwards upper seat lift upwards lower seat lift upwards

D4SL Mix proof valve	
operating	main stroke downwards upper seat lift upwards lower seat lift downwards

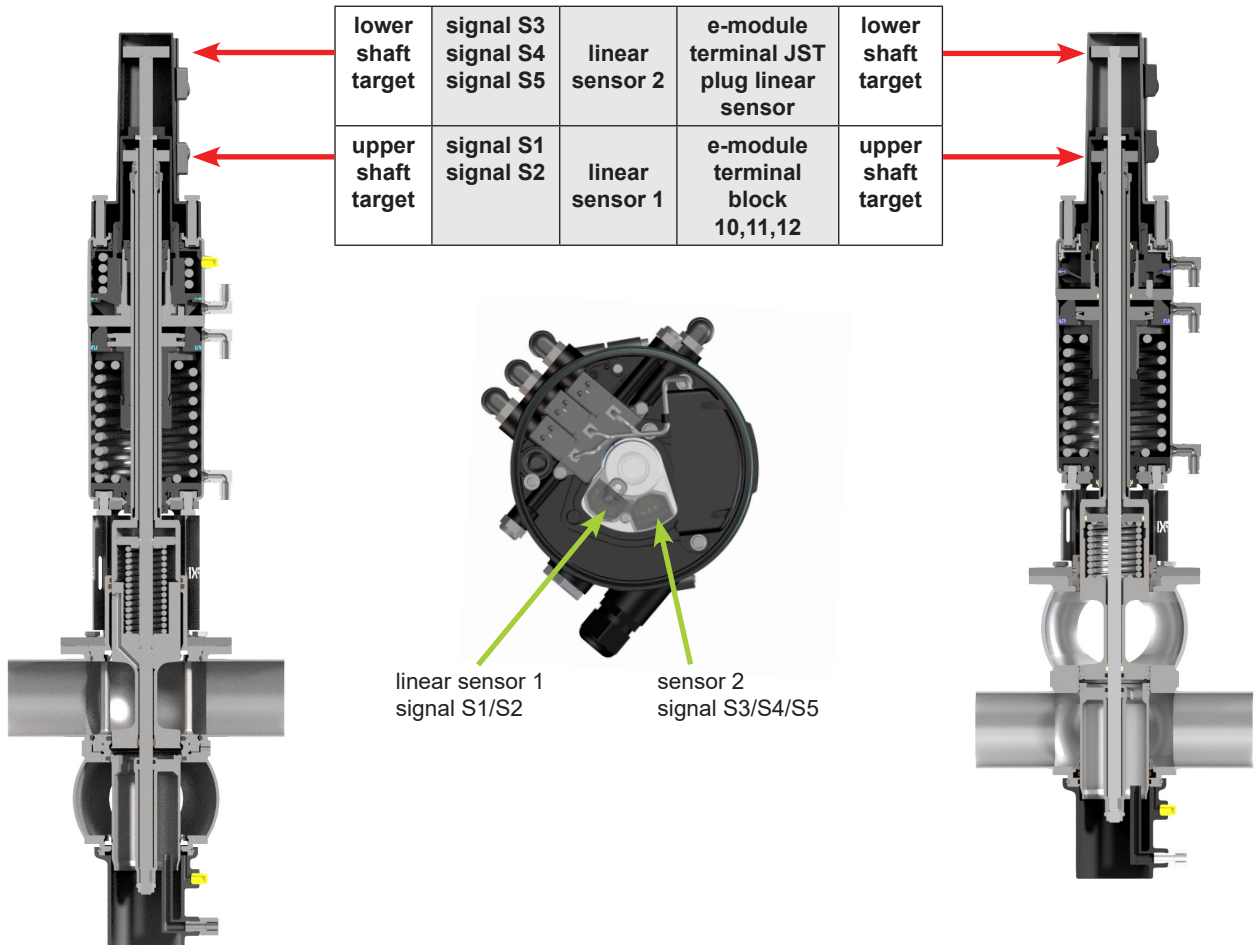

AS-i input data				valve status	Internal linear sensor 1 (S) / Teach data for upper shaft		Internal linear sensor 2 (J) / Teach data for lower shaft			
DI0	DI1	DI2	DI3		signal S1	signal S2	signal S3	signal S4	signal S5	Tolerance band
1	0	0	0	closed	0	1	1	0	0	+/- 1mm
0	1	0	0	open	0	0	0	1	0	+/- 1mm
1	0	1	0	upper seat lift	1	0	1	0	0	+/- 1mm
1	0	0	1	lower seat lift	0	1	0	0	1	+/- 1mm

AS-i output data	solenoid 1 Main	solenoid 2 upper seat lift	solenoid 3 lower seat lift
DO0	1	0	0
DO1	0	1	0
DO2	0	0	1

6. Electronic Module

6.7. AS-i communication / Data signals

6.7.10. AS-i parameter data / status / diagnosis

AS-i parameter data (inverted)			
inputs		outputs	
PI3	not occupied	PO3	not occupied
PI2	Teach mode	PO2	not occupied
PI1	Aux. Voltage	PO1	not occupied
PI0	Service requ.	PO0	Activate Watchdog

AS-i status	
inputs	
S3	EEPROM error
S2	Automatic "unique" duplicate address detection
S1	Periphery fault
S0	Address not permanently stored

AS-i diagnosis	
inputs	
0	Air pressure availed
1	Teach-in-successfully completed

6.8. Service and Maintenance Software CU4plus Toolbox

For the parameterization of the CU4plus AS-i the CU4plus Toolbox Software is available.

The Toolbox kit with appropriate USB/serial cable can be purchased from SPX Flow using the article number H333470.

The latest version of the Toolbox Software is always available from the SPX Flow F&B Sharepoint. Please contact your SPX Flow Sales representative.

This software is designed for PC system software Windows 7, Windows 8.1, Windows 10.

After installation of the CU4plus Toolbox the corresponding control unit is connected with the PC by means of an adapter cable.

The individual functions are described in the CU4plus Toolbox manual.

SPXFLOW

INSTRUCTION MANUAL

ToolBox Service & Maintenance
Software for APV Control Unit CU4plus AS-interface / Direct Connect

CONTROL PROGRAM FOR WINDOWS® OPERATING SYSTEMS

FORM NO.: H33333 VERSION: 02.01.20 READ AND UNDERSTAND THIS MANUAL PRIOR TO OPERATING OR SERVICING THIS PRODUCT.



APV

6. Electronic Module

6.9. Seat Pulsation - Efficiency in Cleaning

For increasing seat cleaning efficiency and reduction of CIP losses, the "Pulsation" can be activated. With this function, the seat lifts can be operated in pulsation mode while the PLC signal activates the seat lift.

2 types of pulsation methods are available:

a) Time based pulsation:

The seat lifting is activated for a period of time = on time.
And the seat lifting is deactivated for a period of time = off time.
For the time based pulsation, the on-time and off-time needs to be set via the CU4plus Toolbox.

b) Stroke based pulsation:

Once the seat lift position has been reached, the solenoid remains active for a defined time = on time.
Then the solenoid is deactivated, the shaft returns to close position, once the shaft passes a certain position of the complete stroke = % of stroke, the solenoid is activated again and the seat lift cycle starts again.

For the stroke based pulsation, default parameters are set.
These can be adjusted within the CU4plus Toolbox.

During pulsation, the feedback for the appropriate seat lift will always be active!

7. Valve Position Indication

7.1. Continuously measuring valve position measuring system

For the internal detection of the valve position indication, a contact-free operating linear sensor is used which is actuated via the magnetic switching cam installed at the valve rod. The nominal measuring range of the measuring system amounts to 0 - 72 mm, relative repetitive accuracy < 0.1 mm.

Within this measuring range, the corresponding positions for closed and open valve position as well as seat lift positions are generated via the teach-in function and permanently saved in the electronic.

7.2. Tolerance band of the valve position measuring system

The tolerance band of the valve position measuring system describes the active measuring range in which the corresponding feedback information, closed or open valve position, is registered. For different process valves also different tolerance bands exist. The adjustment is realized via the ToolBox software.

Tolerance band	Output of feedback signals in range	Recommendation for valve type
T1	+/- 1 mm	e.g. DA3+, D4, D4 SL, D4 PMO, DA4, DT4
T2	+/- 3 mm	e.g. SW4, MS4, UF4
T3	+/- 5 mm	e.g. SV, SVS, DKR

A fixed tolerance band is used for AM1 Valve

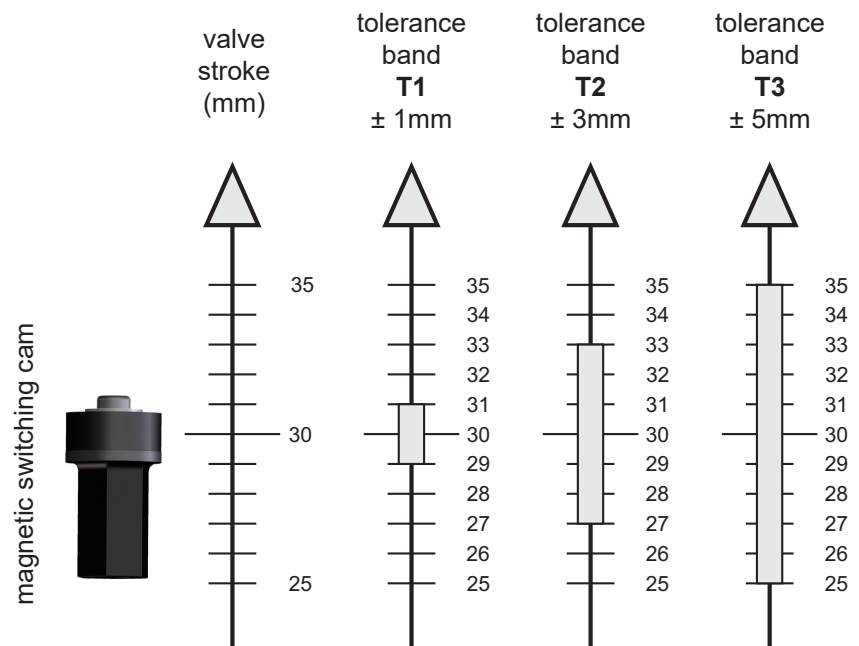

7. Valve Position Indication

7.3. Adjustment of valve position indication / Teach-in

The continuously measuring valve position measuring system is taught via a reference valve movement.

The respective positions for the closed and open valve position as well as for further valve positions, e.g. seat lifting, are travelled to and the corresponding position of the sensor system is permanently stored in the memory of the electronic module. This process is called Teach-In.

The Teach-In is started by pressing the Teach-In key at the electronic module. The key must be pressed permanently for 3 seconds.

After the start of the Teach-In the LED 9 lights up and the valve travels into the corresponding final positions and back into the basic position. The positions of the corresponding valve positions are stored.

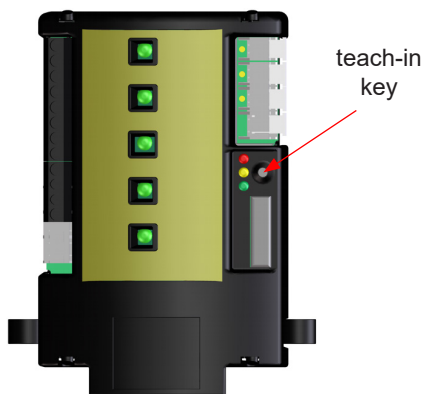

Indication	Status	Action
LED 3-6,9 blink	Delivery status Waiting for teach-in	Start teach-in press teach-in for at least 3 seconds
LED 9 OFF LED 3/4 blink	Teach-in active	Wait Do not control valve via PLC.
LED 9 OFF	Successful teach-in	Valve can be controlled by PLC.
LED 9 ON	Valve service carried out	Start teach-in / press teach-in key for 3 sec.
LED 9 blink	Teach-in not successful, repetition required. Possible reasons for teach-in failure: Compressed air is missing. Supply voltage missing. Switching logic does not fit to valve.	Start teach-in / press teach-in key for 3 sec.

7. Valve Position Indication

7.3.1. To be observed before teach-in:



- Corresponding target is mounted to the valve rod, in case of mixproof valves, two targets are used.

Note! Caution!

The target for CU4plus is not identical with the standard CU target!

- CU4plus AS-i control unit is duly installed on the valve.
- Valve is duly installed in the process.
- **Valve is not manually controlled or controlled by PLC.**
- Control air is connected (requirements, see Technical Data, chapter 4.5.).
- Nominal valve stroke is not restricted, e.g. through chunky products in the valve.
- Selected valve profile complies with the installed process valve (adjustment is realized via CU4plus Toolbox software, delivery status is valve profile type 0, V2-mixproof valve DA4.)

During the Teach-In function, the valve is controlled and moves independently into all operating positions.



As a precaution, the Teach-In function is to be repeated after any valve service or maintenance!

If these instructions are not observed, process failures, product loss or personal injury may occur!

7.4. Use of external sensors

For double seat valves with active seat lift detection (SLD) 2 additional proximity switches are required which are mounted in the actuator area of the DA3+ valve and connected at the electronic module of the CU4plus AS-i.

8. CU Assembly and Startup

8.1. Valves with turning actuator, e.g. for butterfly valve

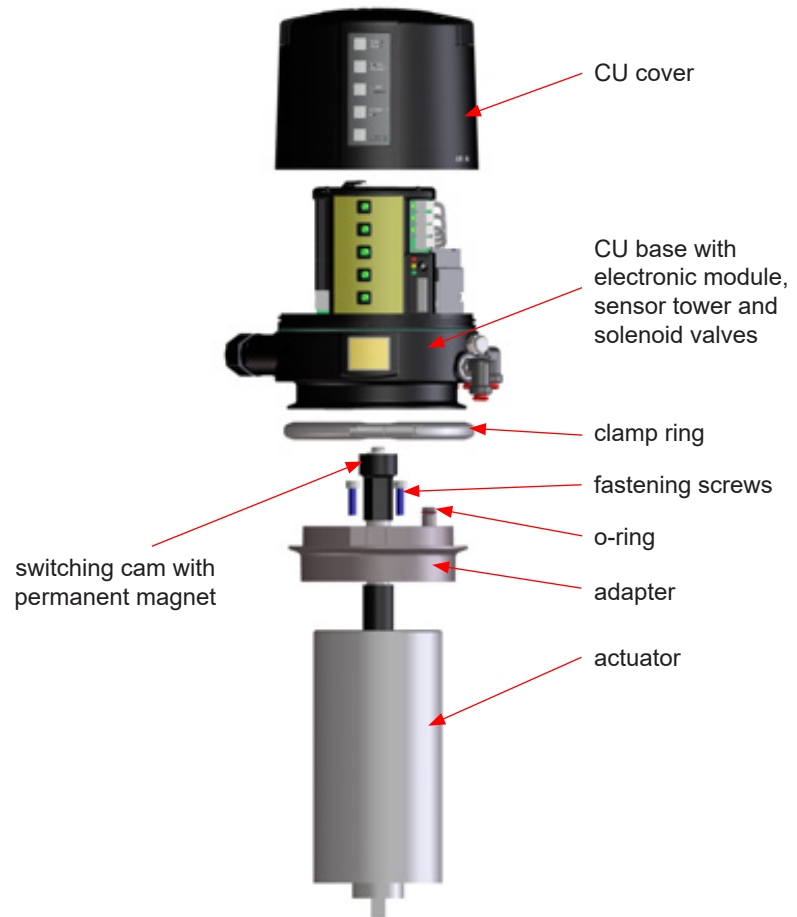

Caution!

The permanent magnet is made of fragile material and must be protected against mechanical load . – Risk of fracture! The magnetic fields can damage or delete data carrier or influence electronic and mechanic components.

Assembly of the control unit on the valve

1. Assembly of the adapter on the turning actuator.
Fasten with 3 screws.
See to the right positioning of the o-rings on the lower side of the adapter and in the groove of the air transfer stud.
2. Install switching cam with shaft rod prolongation.
Secure with Loctite semi-solid and fasten it.
3. Place the control unit via the operating cam onto the adapter.
Observe alignment.
4. Attach the clamp rings and fasten them with the screws.

8. CU Assembly and Startup

8.1.1. Pneumatic connection



Supply air:

Caution!

Shut off the compressed air supply before connecting the air hose!

See that the air hose is professionally cut to length. Use a hose cutter for this purpose.

Pneumatic air for valve actuator:

For the assembly of the control unit on the turning actuator with integrated air transfer, air hosing between the control unit and the actuator is not necessary.

Exhaust air:

As a standard, the exhaust air connection is equipped with a silencer. If required, the silencer can be removed and the exhaust air can be hosed separately when it must be led off to the exterior, for example.

8.1.2. Electric connection



Attention!

Electric connections shall only be carried out by qualified personnel!

See to a professional execution and installation of the AS-interface network.

Observe the Safety Instructions specified in chapter 2.

8.1.3. Startup

After proper assembly and installation of the control unit, startup can be undertaken as described below:

1. Switch on the air supply.
2. Switch on the voltage supply.
3. Adjust AS-i address at the CU4plus AS-i.
4. Adjust corresponding logic profile in accordance with the process valve used (if this has not been determined for the delivery status).

Start Teach-In. It is mandatory to observe the corresponding prerequisites (**see chapter 7.3.**).

8. CU Assembly and Startup

8.2. Single seat valve

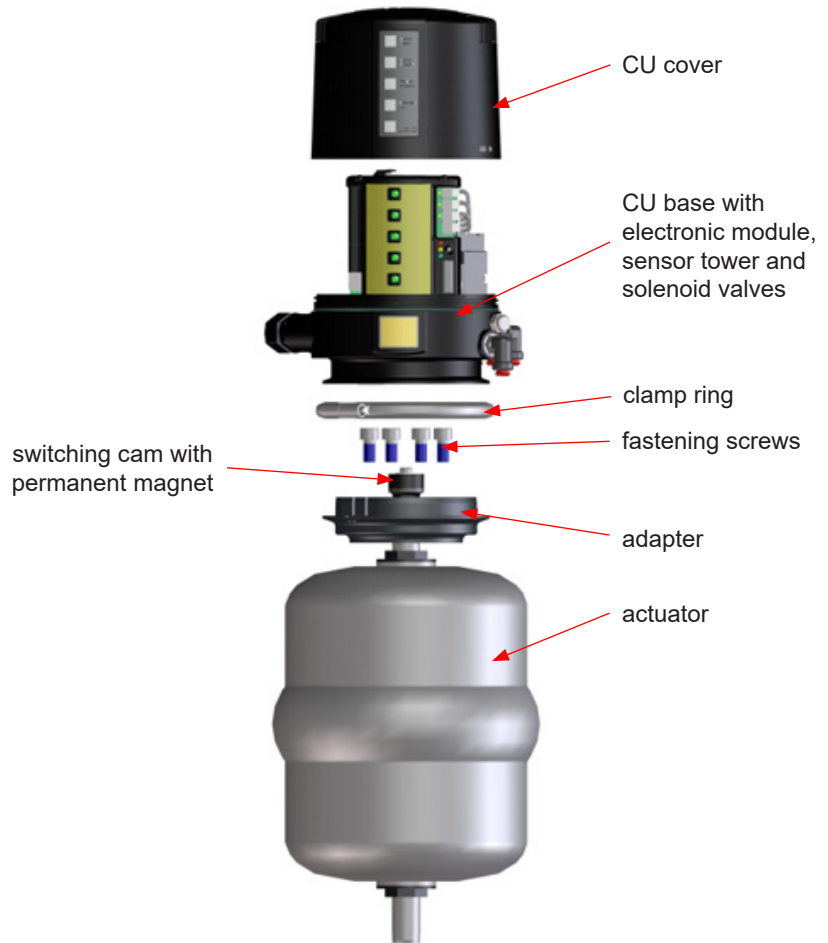

Caution!

The permanent magnet is made of fragile material and must be protected against mechanical load . – Risk of fracture!
The magnetic fields can damage or delete data carrier or influence electronic and mechanic components.

Assembly of the control unit on the valve

1. Assembly of the adapter on the single seat valve. Fasten with 4 screws.
2. Secure switching cam with Loctite semi-solid and fasten it.
3. Place the control unit via the switching cam onto the adapter. Observe alignment!
4. Attach the clamp rings and fasten them with the screws.

8. CU Assembly and Startup

8.2.1. Pneumatic connection



Supply air:

Caution! Shut off the compressed air supply before connecting the air hose!

See that the air hose is professionally cut to length. Use a hose cutter for this purpose.

Pneumatic air for valve actuator:

Connect the pneumatic air connection **Y1** with the valve actuator.

- For the CU41N (**with logic NOT element**), the pneumatic air connection N must be connected with the spring side of the actuator.
See to the spring side of the actuator during the assembly of the pressure-reducing valve.

Exhaust air:

As a standard, the exhaust air connection is equipped with a silencer. If required, the silencer can be removed and the exhaust air can be hoses separately when it must be led off to the exterior, for example.

8.2.2. Electric connection



Attention! Electric connections shall only be carried out by qualified personnel.

See to a professional execution and installation of the AS-interface network.

Observe the Safety Instructions specified in chapter 2.

8.2.3. Startup

After proper assembly and installation of the control unit, startup can be undertaken as described below:

1. Switch on the air supply.
2. Switch on the voltage supply.
3. Adjust AS-i address at the CU4plus AS-i.
4. Adjust corresponding logic profile in accordance with the process valve used (if this has not been determined for the delivery status).
5. Start Teach-In. It is mandatory to observe the corresponding prerequisites (**see chapter 7.3.**).

8. CU Assembly and Startup

8.3. Double seat valve DA3+ with activated Seat Lift Detection (SLD)

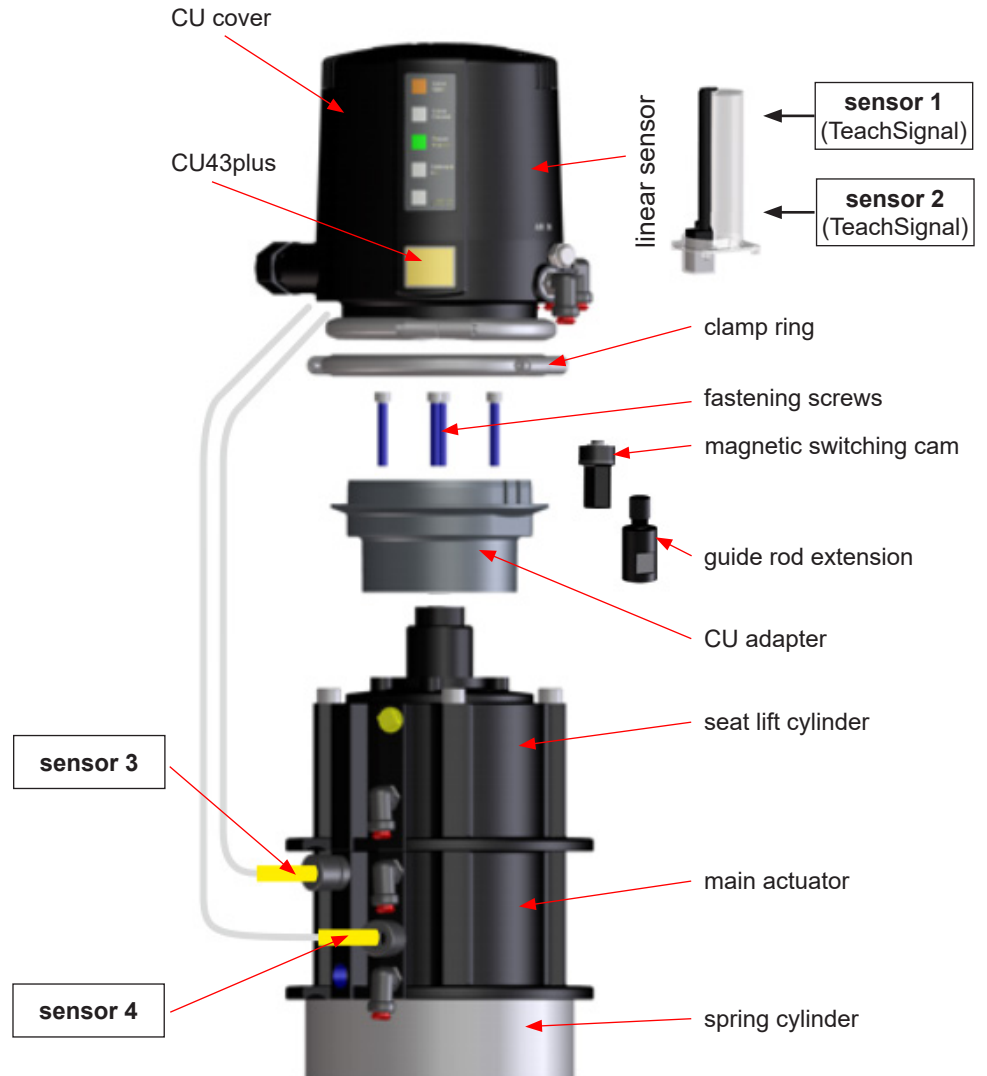

Assembly of the control unit on the valve

1. Assembly of the adapter on the double seat valve. Fasten with 4 screws.
2. Align air connections of the control unit to the valve actuator.
3. Place the control unit onto the adapter. Observe alignment!
4. Attach the clamp rings and fasten them with the screws.
5. Assemble the external proximity switches at the actuator.

8. CU Assembly and Startup

8.3.1 Pneumatic connection



Supply air:

Caution! Shut off the compressed air supply before connecting the air hose!

See that the air hose is professionally cut to length. Use a hose cutter for this purpose.

Pneumatic air to valve actuator:

Connect pneumatic air connection **Y1** with the valve actuator.
Main actuator

Connect pneumatic air connection **Y2** with the valve actuator.
Seat lifting - upper valve seat

Connect pneumatic air connection **Y3** with the valve actuator.
Seat lifting – lower valve seat

Exhaust air:

As a standard, the exhaust air connections **A1** and **A2** are equipped with a silencer. If required, the silencer can be removed and the exhaust air can be hoses separately when it must be led off to the exterior, for example.

8.3.2. Electric connection



Attention! Electric connections shall only be carried out by qualified personnel.

See to a professional execution and installation of the AS-interface network.

Observe the Safety Instructions specified in chapter 2.

8.3.3. Connection of external proximity switches

The electric connection of the proximity switches specified by SPX is undertaken according to the terminal layout described in chapter 6.

The mechanic assembly of the proximity switches is carried out at the actuator of the corresponding double seat valves. Observance of the instruction manual for double seat valves is essential!

8. CU Assembly and Startup

8.3.4. Startup

After proper assembly and installation of the control unit, startup can be undertaken as described below:

1. Switch on the air supply.
2. Switch on the voltage supply.
3. Adjust AS-i address at the CU4plus AS-i.
4. Adjust corresponding logic profile in accordance with the process valve used (if this has not been determined for the delivery status).
5. Start Teach-In. It is mandatory to observe the corresponding prerequisites (**see chapter 7.3.**).

8. CU Assembly and Startup

8.4. Double seat mix proof valves D4, D4 SL, D4 PMO, DA4

V1

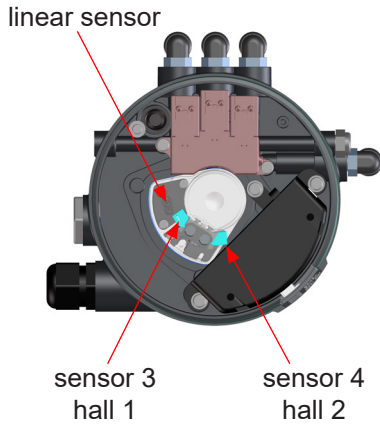

V2

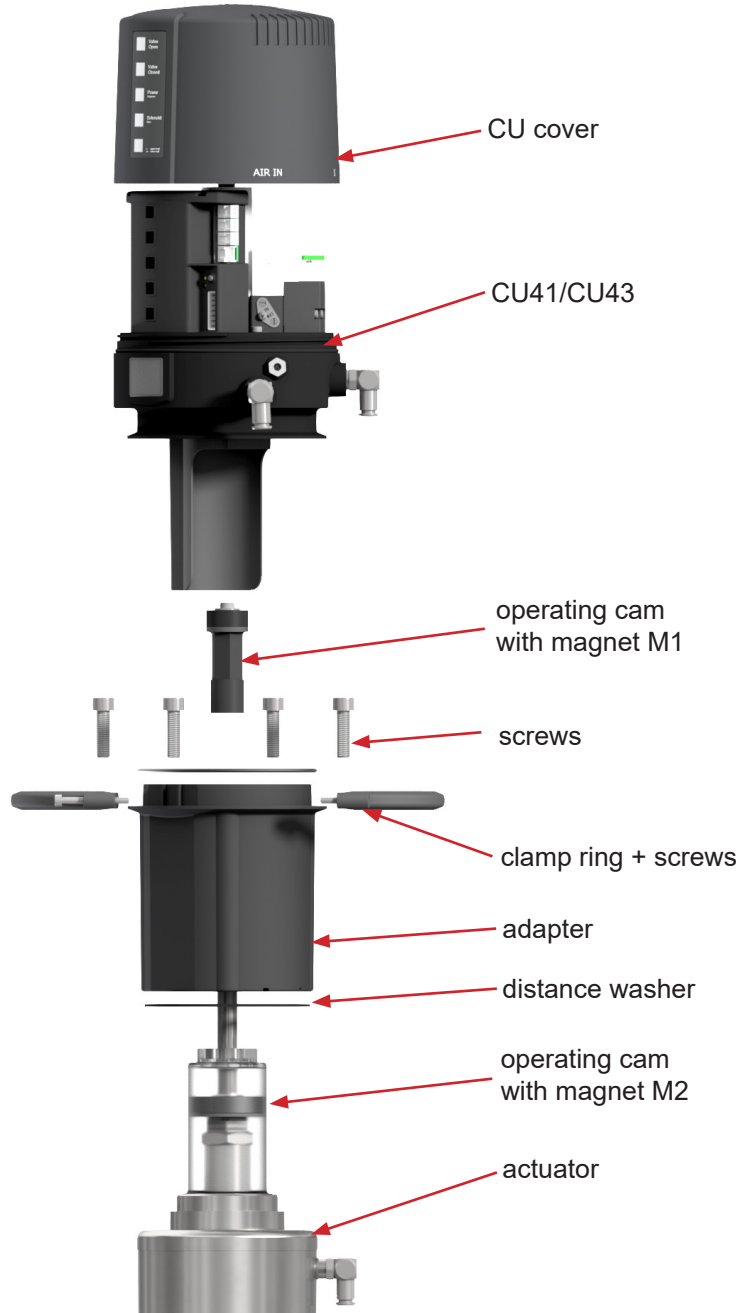
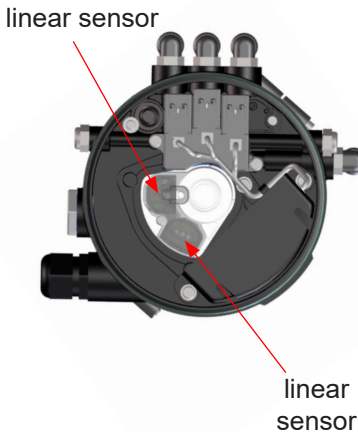

Assembly of the control unit on the valve

1. Assemble the magnet M2 on the upper shaft under the stop screw.
2. Assemble the adapter with the 4 screws on the double seat valve.
3. Assemble the operating cam M1 with guide rod extension on the guide rod.
4. Place the control unit onto the adapter. Observe alignment!
5. Attach the clamp rings and fasten them with the 2 screws.
6. Align air connections of the control unit to the valve actuator.

8. CU Assembly and Startup

8.4.1 Pneumatic connection

Supply air:



Caution!

Shut off the compressed air supply before connecting the air hose!

Make sure that the air hose is professionally cut to length. Use a hose cutter for this purpose.

Pneumatic air to valve actuator:

Connect pneumatic air connection **Y1** with the valve actuator. Main actuator 1

Connect pneumatic air connection **Y2** with the valve actuator. (seat lifting - upper valve seat) 2

Connect pneumatic air connection **Y3** with the valve actuator. (seat lifting – lower valve seat) 3

Exhaust air:

As a standard, the exhaust air connections **A1** and **A2** are equipped with a silencer. If required, the silencer can be removed and the exhaust air can be hosed separately when it must be led off to the exterior, for example.

8.4.2 Electric connection



Attention! Electric connections shall only be carried out by qualified personnel.

See to a professional execution and installation of the AS-interface network.

Observe the Safety Instructions specified in chapter 2.

8. CU Assembly and Startup

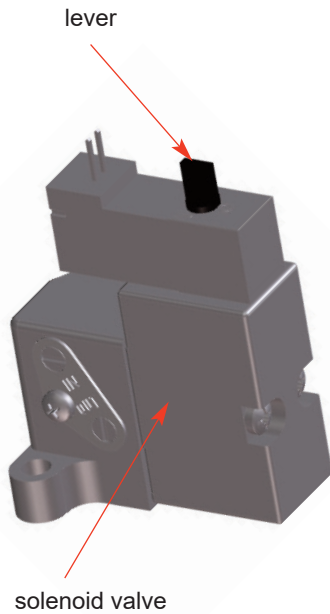

8.4.3 Connection of external proximity switches

The electric connection of the proximity switches specified by SPX FLOW is undertaken according to the terminal layout described in chapter 6.

The mechanic assembly of the proximity switches is carried out at the actuator of the corresponding double seat valves. Observance of the instruction manual for double seat valves is essential!

8.4.4 Startup

After proper assembly and installation of the control unit, startup can be undertaken as described below

1. Switch on the air supply
2. Switch on the voltage supply.
3. Check the solenoid valves by turning the lever on the upper side by 90°.
4. For final adjustments of the feedback position switches please use the Teach function.

V1 version:

Before starting the Teach function, observe and carry out the steps for pre-setting as described on pages 58, 59, 60.

V2 version:

No pre-settings required.
 Select the appropriate valve profile.
 Start Teach-In (see chapter 7.3.).

8. CU Assembly and Startup

8.5. Double seat tank outlet valve DT4 SL

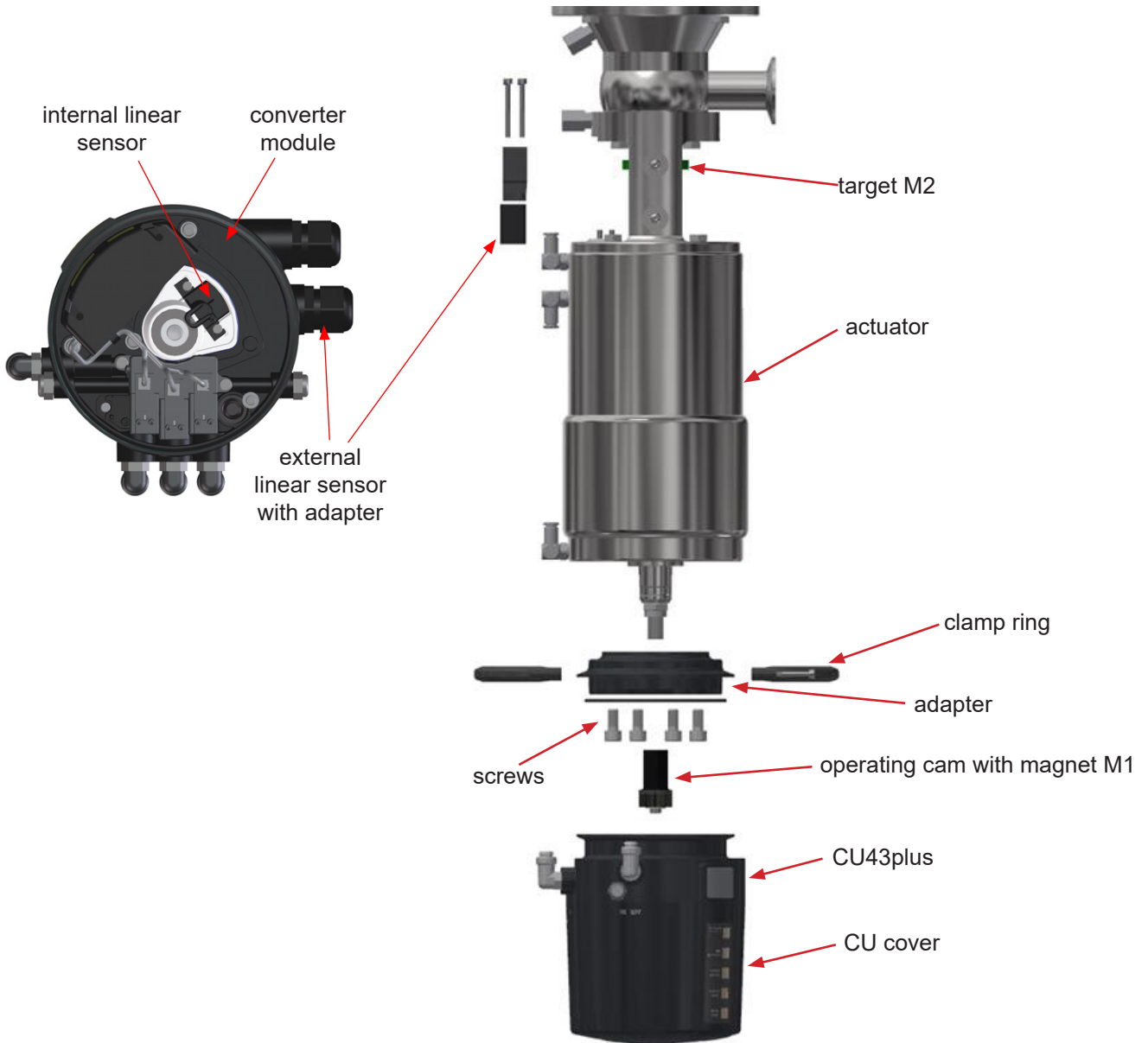

Assembly of the control unit on the valve

1. Assemble the target M2 on the lower shaft, see oper. manual DT4 SL.
2. Assemble the external linear sensor with the adapter in the yoke area. Insert cable through cable grommet and cable gland then connect the cable to the E-modul.
3. Assemble the adapter with the 4 screws on the double seat valve.
4. Assemble the operating cam M1 on the guide rod.
5. Place the control unit onto the adapter. Observe alignment!
6. Attach the clamp rings and fasten them with the 2 screws.
7. Align air connections of the control unit to the valve actuator.

8. CU Assembly and Startup

8.5.1 Pneumatic connection



Supply air:

Caution!

Shut off the compressed air supply before connecting the air hose!

Make sure that the air hose is professionally cut to length. Use a hose cutter for this purpose.

Pneumatic air to valve actuator:

Connect pneumatic air connection **Y1** with the valve actuator. Main actuator 1

Connect pneumatic air connection **Y2** with the valve actuator. (seat lifting - upper valve seat) 2

Connect pneumatic air connection **Y3** with the valve actuator. (seat lifting – lower valve seat) 3

Exhaust air:

As a standard, the exhaust air connections **A1** and **A2** are equipped with a silencer. If required, the silencer can be removed and the exhaust air can be hosed separately when it must be led off to the exterior, for example.

8.5.2 Electric connection



Attention! Electric connections shall only be carried out by qualified personnel.

Observe the Safety Instructions specified in chapter 2.

8. CU Assembly and Startup

8.6. Aseptic Double seat mix proof valve AM1

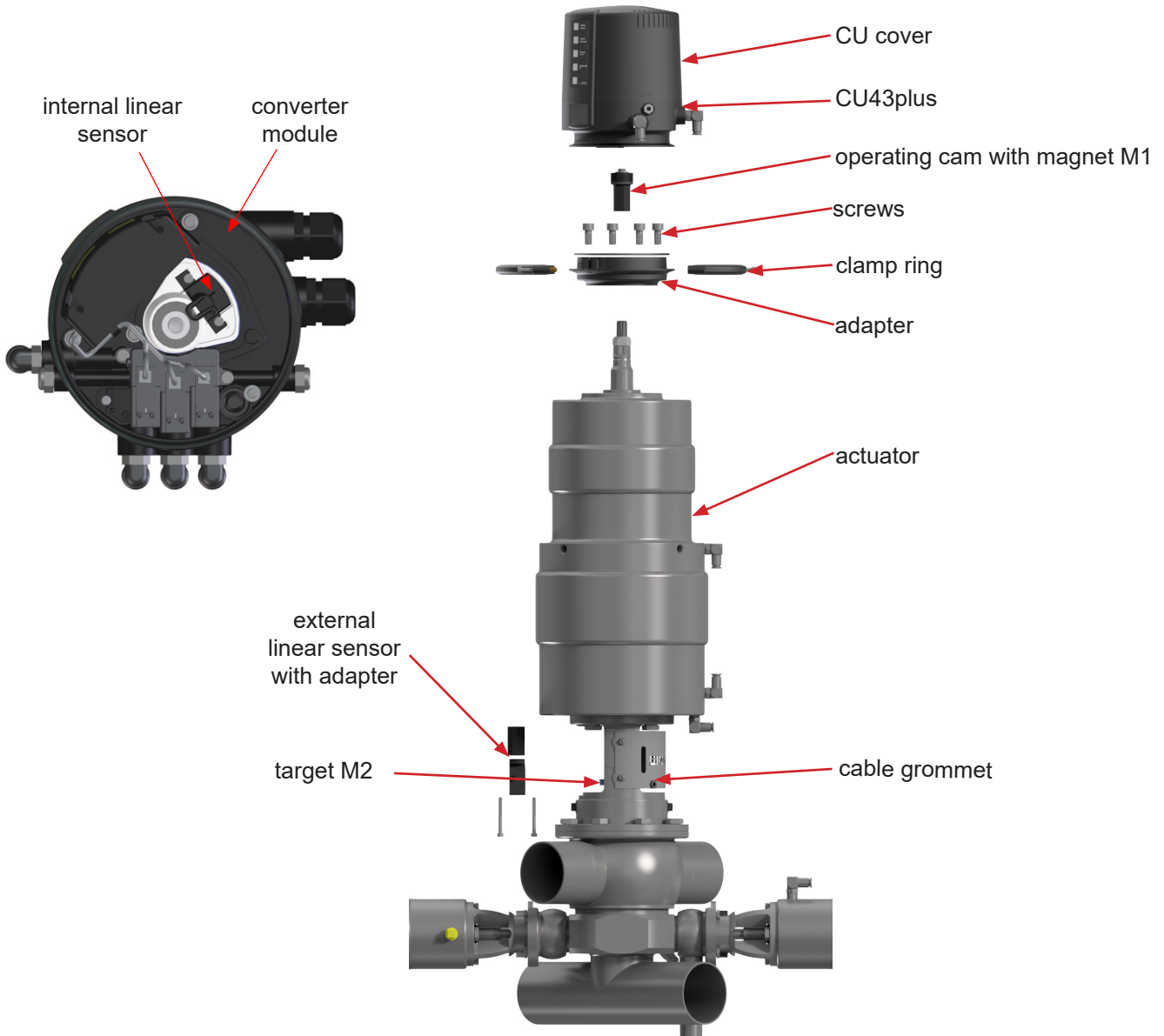

Assembly of the control unit on the valve

1. Assemble the target M2 on the upper shaft, see oper. manual AM1.
2. Assemble the external linear sensor with the adapter in the yoke area. Insert cable through cable gland and connect to the E-modul.
3. Assemble the adapter with the 4 screws on the double seat valve.
4. Assemble the operating cam M1 on the guide rod.
5. Place the control unit onto the adapter. Observe alignment!
6. Attach the clamp rings and fasten them with the 2 screws.
7. Align air connections of the control unit to the valve actuator.

8. CU Assembly and Startup

8.6.1 Pneumatic connection



Supply air:

Caution!

Shut off the compressed air supply before connecting the air hose!

Make sure that the air hose is professionally cut to length. Use a hose cutter for this purpose.

Pneumatic air to valve actuator:

Connect pneumatic air connection **Y1** with the valve actuator. Main actuator 1

Connect pneumatic air connection **Y2** with the valve actuator. (seat lifting - upper valve seat) 2

Connect pneumatic air connection **Y3** with the valve actuator. (seat lifting – lower valve seat) 3

Exhaust air:

As a standard, the exhaust air connections **A1** and **A2** are equipped with a silencer. If required, the silencer can be removed and the exhaust air can be hosed separately when it must be led off to the exterior, for example.

8.6.2 Electric connection



Attention! Electric connections shall only be carried out by qualified personnel.

Observe the Safety Instructions specified in chapter 2.

8. CU Assembly and Startup

8.7. Pre-settings

8.6.1. Pre-settings of CU4plus AS-i on D4 mix proof valve V1

Step	Description
1	assembly of adapter
2	assembly of CU4plus connect air hoses with CU and D4 valve actuator - Air out 1 / main actuator - Air out 2 / upper seat lift actuator - Air out 3 / lower seat lift actuator
3	CU4plus AS-i power ON switch compressed control air supply ON
4	connect CU4 Toolbox
5	start Toolbox software with password access - also see: CU4 Toolbox manual
6	open pull down menu "Valve settings" adjust valve profile D4 and write settings to CU
7	CU signalizes "no teach data" LED 3/4 - perfault blink together with LED 5/6/9 blink
8	adjust hall sensors S3 (Toolbox) = tower spindle 1 S4 (Toolbox) = tower spindle 2
8a	sensor S3 / tower spindle 1 - not used
8b	adjust S4 / tower spindle 2 manually activate solenoid 1 - valve to open turn tower spindle 2 until blue LED at hall sensor is ON turn tower spindle 2 counter clockwise until blue LED is just OFF turn tower spindle 2 clockwise 2 times (LED should still be ON) manually de-activate solenoid 1 - valve to return into closed position
9	start teach routine press teach button (next to LED 9) until LED 9 is ON teach routine proceeds automatically to learn every valve position after successful teach the valve closed position is indicated (orange LED 5)

8. CU Assembly and Startup

8.7. Pre-settings

8.7.2. Pre-settings of CU4plus AS-i on D4 SL mix proof valve V1

Step	Description
1	assembly of adapter
2	assembly of CU4plus connect air hoses with CU and D4 valve actuator - Air out 1 / main actuator - Air out 2 / upper seat lift actuator - Air out 3 / lower seat lift actuator
3	CU4plus AS-i power ON switch compressed control air supply ON
4	connect CU4 Toolbox
5	start Toolbox software with password access - also see: CU4 Toolbox manual
6	open pull down menu "Valve settings" adjust valve profile D4SL and write settings to CU
7	CU signalizes "no teach data" LED 3/4 - perifaault blink together with LED 5/6/9 blink
8	adjust hall sensors S3 (Toolbox) = tower spindle 1 S4 (Toolbox) = tower spindle 2
8a	adjust S3 / tower spindle 1 no solenoid active turn tower spindle 1 until blue LED at hall sensor is ON continue turning tower spindle 1 until LED at hall sensor is OFF turn tower spindle 1 2 times counter clockwise (LED should still be ON) manually activate solenoid 3 - lower seat lift, LED at hall sensor OFF manually deactivate solenoid 3 - lower seat lift, LED at hall sensor is ON
8b	adjust S4 / tower spindle 2 manually activate solenoid 1 - valve to open turn tower spindle 2 until blue LED at hall sensor is ON turn tower spindle 2 counter clockwise until blue LED is just OFF turn tower spindle 2 clockwise 2 times (LED should still be ON) manually de-activate solenoid 1 - valve to return into closed position
9	start teach routine press teach button (next to LED 9) until LED 9 is ON teach routine proceeds automatically to learn every valve position after successful teach the valve closed position is indicated (orange LED 5)
10	check if valve positions are correct either use manual override at the solenoid or CU4Toolbox to activate the valve postions open, upper seat lift, lower seat lift and check the appropriate output signals and LED

8. CU Assembly and Startup

8.7. Pre-settings

8.7.3. Pre-settings of CU4plus AS-i on DA4 mix proof valve V1

Step	Description
1	assembly of adapter
2	assembly of CU4plus connect air hoses with CU and D4 valve actuator - Air out 1 / main actuator - Air out 2 / upper seat lift actuator - Air out 3 / lower seat lift actuator
3	CU4plus AS-i power ON switch compressed control air supply ON
4	connect CU4 Toolbox
5	start Toolbox software with password access - also see: CU4 Toolbox manual
6	open pull down menu "Valve settings" adjust valve profile DA4 and write settings to CU
7	CU signalizes "no teach data" LED 3/4 - perifaault blink together with LED 5/6/9 blink
8	adjust hall sensors S3 (Toolbox) = tower spindle 1 S4 (Toolbox) = tower spindle 2
8a	adjust S3 / tower spindle 1 manually activate solenoid 3 - lower seat lift turn tower spindle 1 until blue LED at hall sensor is ON turn tower spindle 1 further clockwise until LED just is OFF turn tower spindle 1 2 times counter clockwise (LED should still be ON) manually de-activate solenoid 3 - valve to return into closed position
8b	adjust S4 / tower spindle 2 manually activate solenoid 1 - valve to open turn tower spindle 2 until blue LED at hall sensor is ON turn tower spindle 2 counter clockwise until blue LED is just OFF turn tower spindle 2 clockwise 2 times (LED should still be ON) manually de-activate solenoid 1 - valve to return into closed position
9	start teach routine press teach button (next to LED 9) until LED 9 is ON teach routine proceeds automatically to learn every valve position after successful teach the valve closed position is indicated (orange LED 5)
10	check if valve positions are correct either use manual override at the solenoid or CU4Toolbox to activate the valve positions open, upper seat lift, lower seat lift and check the appropriate output signals and LED

8. CU Assembly and Startup

8.8. Replacement of CU3 versions

Replacement of a standard CU3 AS-i

All CU41 variants can substitute a CU3 control unit without changing the signal routing. When replacing the CU3, the larger dimensions of the CU4 control unit must, however, be considered. If a CU43 is to replace a CU33 control unit, the change of the seat lifting signals must be observed.

The following table shows the details.

AS-interface output data bit	CU33	CU43
DO0	main valve	main valve
DO1	lower seat lifting	upper seat lifting
DO2	upper seat lifting	lower seat lifting

In order to prevent the activation of the wrong seat lift after CU replacement, the following adaptations can be carried out:

- Change in the control software. – or -
- The interchange of the electrical connections of the pneumatic valves 2 and 3 at the electronic module of CU43. In this case, the signals of CU43 as well as of CU33 can be controlled.



Note!

The air hoses leading to the actuators MUST NOT be exchanged. For the lower seat lift, the CU is equipped with a separate exhaust air channel due to the larger volume of the actuator. A mix-up of the air hoses can lead to disruption in operation.

Replacement of a standard CU33 AS-i SLD

Adjust the compatibility mode with the ToolBox software.

The CU43plus AS-i will work in the same manner as the CU33 AS-i SLD.

9. Accessories and Tools

Assembly/disassembly - adapter on valve actuator:

- hexagon socket wrench 6 mm
- screwdriver 4 mm

Assembly/disassembly – CU on adapter:

- hexagon socket wrench 3 mm

Assembly/disassembly – electronic module:

- Torx wrench TX20
- screwdriver 3.5 mm

Assembly/disassembly – feedback unit:

- Torx wrench TX15

Assembly/disassembly – electronic modules:

- Torx wrench TX20

Assembly/disassembly – air connections:

- jaw wrench SW13

Assembly/disassembly – pressure relief valve:

- Torx wrench TX10

Loctite semi-solid

jaw wrench



torx wrench



screwdriver



hexagon socket wrench

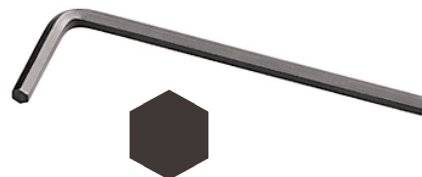

10. Service

10.1. Dismantling

Before disassembly, verify the following items:

- The valve must be in safety position and must not be controlled!
- Shut off air supply!
- Cut off current to control unit, i.e. interrupt the supply voltage!

Solenoid valve (4, 5, 6)

- + Open the CU cover by turning in anticlockwise direction.
- + Release the plug connection at the electronic module for the corresponding solenoid valve.
- + Release and remove the 2 screws (20) TX20.
- + Replace the solenoid valve.
- + Assembly in reverse order. See to a proper fit of the flat seal!

Electronic module (2)

Before releasing the cable connections make sure that all lines are de-energised!

- + Open the CU cover by turning in anticlockwise direction.
- + Release the plug connection of the solenoid valves.
- + Release the cable from the terminal strip, all terminals 1-8.
- + Release and remove the 3 screws (20) TX20.
- + Replace the electronic module.
- + Assembly in reverse order.

Feedback unit

Before releasing the cable connections make sure that all lines are de-energised!

- + Open the cover.
- + Release the cable for the linear sensors from the terminal strip, terminals 3-8.
- + Release the clamp ring and lift the CU4 from the adapter.
- + Remove the 4 screws (9) TX15 at the lower side of the CU base (1).
- + Take out the feedback unit to the bottom.

Linear sensor

The linear sensor can only be replaced at the dismantled feedback unit.

- + Remove the 2 screws (14) TX10.
- + Release the plug connection at the electronic module.
Dismantle the linear sensor.
- + Assembly in reverse order.
- + Carry out Teach-In.

11. Trouble Shooting

Failure	Remedy
Valve position is not indicated.	Carry out teach-in.
	Check fastening of magnetic switching cam.
	Check adjusted logic profile and process valve.
Feedback via proximity switches is missing.	Check positioning of proximity switches.
	Check AS-i bus communication.
	Check cabling to the electronic module.
LED indication is missing.	Check AS-i bus communication.
	Check cabling to the electronic module.
Control Unit CU41 installed on Butterfly valves	
Movement of valve flap is missing with actuated solenoid valve.	Check if right control unit is installed. Check label in type window of control unit: CU41plus-T AS-i
	Check valve movement with manual at solenoid valve.
	Check cabling between electronic module and solenoid valve.
	Check compressed air (min. 6 bar).
	Bore for transfer of control air to turning actuator must be open.
Air leakage at lower side of adapter.	Check o-rings of adapter.

11. Trouble Shooting

Failure	Remedy
Control Unit CU41 installed on Single seat, Double seal and Double seat valves	
Valve position movement is missing with actuated solenoid valve.	Check if right control unit is installed. Check label in type window of control unit: CU41plus-S AS-i CU41Nplus-S AS-i CU41plus-M AS-i CU41plus-D4-V1-V2 AS-i
	Check valve movement with manual at solenoid valve.
	Check cabeling between electronic module and solenoid valve.
	Check compressed air (min. 6 bar).
	Check control air connection between the CU41 and the valve actuator.
Control Unit CU43 installed on Double seat valves with SLD	
Valve position movement is missing with actuated solenoid valve.	Check if right control unit is installed. Check label in type window of control unit: CU43plus-M AS-i CU43plus-D4-V1-V2 AS-i CU43plus DT4 CU43plus AM1
	Check valve movement with manual at solenoid valve.
	Check cabeling between electronic module and solenoid valve.
	Check compressed air (min. 6 bar).
	Check control air connection between the CU43 and the DA3 / DA4 / D4 SL / D4 PMO / DT4 SL / AM1 actuator.

12. Spare Parts Lists

The reference numbers of spare parts for the different control unit designs and adapters are included in the attached spare parts drawings with corresponding lists.

When you place an order for spare parts, please indicate the following data:

- number of parts required
- ID number
- reference number
- parts designation

Data are subject to change.

Information contained in this document is subject to change without notice and does not represent a commitment on the part of SPX FLOW, Inc.. No part of this document may be reproduced or transmitted in any form or by any means, electronic or mechanical, including photocopying and recording, for any purpose, without the express written permission of SPX FLOW, Inc..

Spare Parts list

Control Unit CU4 plus AS-i extended



Date: 04.04.24
 Name: C.Keil
 Reviewed: N.Splietthof

SPX FLOW

Page 1 of 9

Date:
 Name:
 Reviewed:

RN 01.044.6

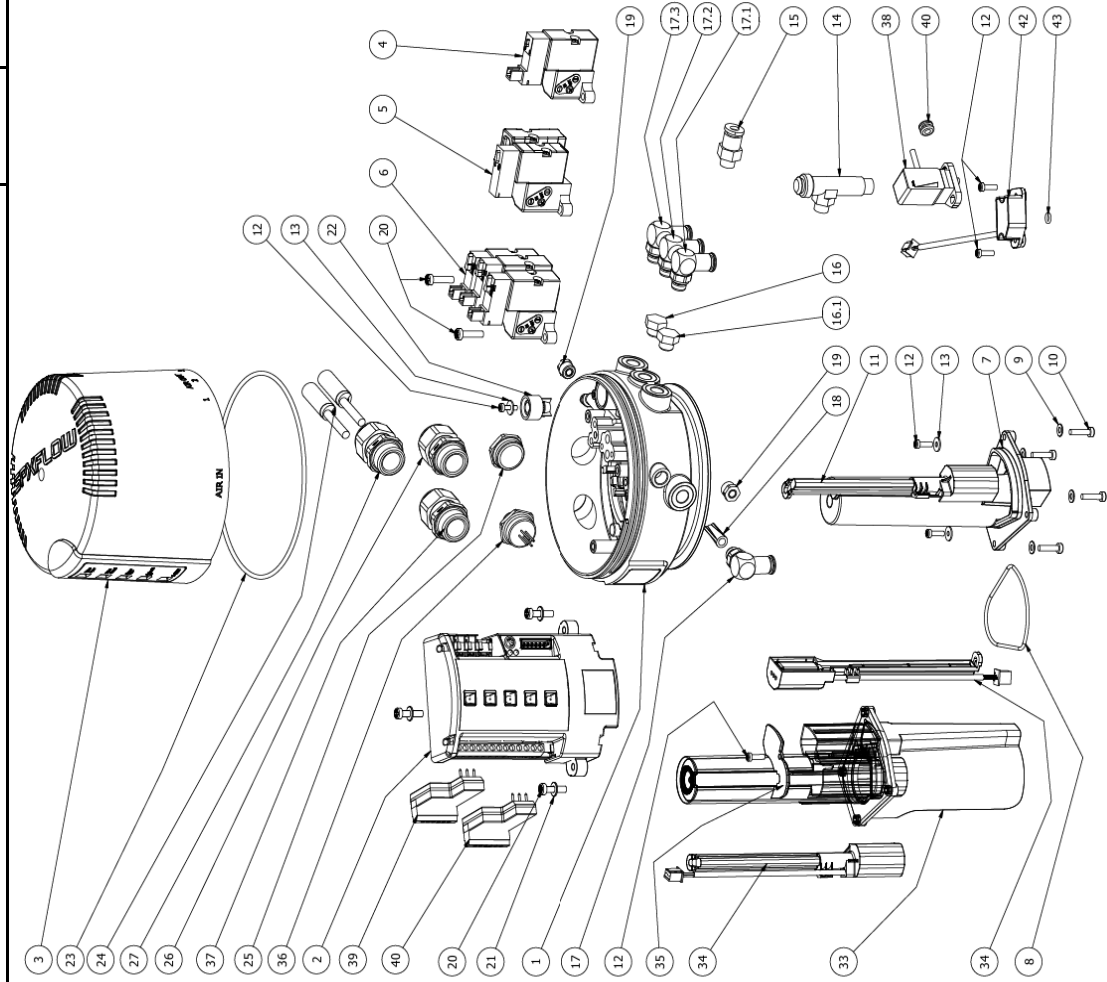

Information contained in this document is subject to change without notice and does not represent a commitment on the part of SPX FLOW, Inc.. No part of this document may be reproduced or transmitted in any form or by any means, electronic or mechanical, including photocopying and recording, for any purpose, without the express written permission of SPX FLOW, Inc..

Spare parts list

Control Unit CU4 plus AS-i extended CU4plus-S AS-i ext.



Date:	04.04.24				
Name:	C.Keil				
Reviewed:	N.Spleithoff				
Date:				Page	2
Name:					9
Reviewed:					RN 01.044.6

SPX FLOW

pos. item	Quantity	Description, product contacted seals with reference number	required in version	Material	Part no.	pos. item	Quantity	Description, product contacted seals with reference number	required in version	Material	Part no.
1	1	CU41-Base	CU41	PA6.6 GF30	H319853	18	1	CU4 air filter	CU41+43	PE	H320223
1	1	CU43-Base	CU43	PA6.6 GF30	H319857	19	1	Sound reducer	CU41+43	Nickel-plated brass	H208826
2	1	CU4plus AS-i-SLD E-Modul	CU41+43	Zytel 70G33L	H333117	20	5	Ejot Delta PT screw 40 x 16	CU41+43	A2	H320365
3	1	CU4 Cover	CU41+43	PA12 Black	H325602	21	3	Washer DIN125 I=4,3	CU41+43	A2	H79576
4	1	Solenoid valve 1EMV	CU41	PPS	H319950	22	1	CU4 overflow valve	CU41+43	PPS	H320352
6	1	Solenoid valve 3 EMV	CU43	PPS	H319952	23	1	O-ring 120,32 x 2,62	CU41+43	NBR	H320402
7	1	CU4plus Sensortower	CU41+43	Grilamid TR90	H321498	25	1	Plug V-NE-SD M20x1,5	CU43	PA black	H324895
8	1	O-ring 47.29 x 2.62	CU41+43	NBR	H320401	26	1	Screwed cable gland M20x1,5 ø5-9	CU41	PA black	H320372
9	4	Washer DIN125 A=3,7	CU41+43	A2	H323771	36	1	Female Flange M12x1,5 - 4pin	CU41+43	1.4404	H338108
10	4	Ejot Delta PT screw 35 x 14	CU41+43	A2	H320364						
11	1	CU4plus sensor cp.	CU41+43	H324877							
12	3	Ejot Delta PT screw 30 x 10	CU41+43	H320363							
13	3	Washer DIN9021 A=3,2	CU41+43	H320404							
16.1	1	Plug G1/8" with o-ring	CU43	H320482							
17	1	Elbow connector G1/8" 6x1	CU41+43	H208825							
	1	Elbow connector G1/8" 1/4" OD	CU41+43	H312732							
	1	Elbow connector G1/8" 6x1	CU41+43	H208825							
17.1	1	Elbow connector G1/8" 1/4" OD	CU41+43	H312732							
	1	Elbow connector G1/8" 1/4" OD	CU43	H208825							
17.2	1	Elbow connector G1/8" 1/4" OD	CU43	H312732							
	1	Elbow connector G1/8" 1/4" OD	CU43	H208825							
17.3	1	Elbow connector G1/8" 6x1	CU43	H208825							
	1	Elbow connector G1/8" 1/4" OD	CU43	H312732							

CU4plus Adapter

Adapter Spareparts information to be found in document: RN01.044.3-1

Information contained in this document is subject to change without notice and does not represent a commitment on the part of SPX FLOW, Inc.. No part of this document may be reproduced or transmitted in any form or by any means, electronic or mechanical, including photocopying and recording, for any purpose, without the express written permission of SPX FLOW, Inc..

Spare parts list

Control Unit CU4 plus AS-i extended CU41Nplus-S AS-i ext.



Date:	04.04.24				
Name:	C. Keil				
Reviewed:	N. Spilthoff				
Date:				Page	3
Name:					9
Reviewed:					RN 01.044.6

SPX FLOW

pos. item	Quantity	Description, product contacted seals with reference number	required in version	Material	Part no.	Description, product contacted seals with reference number	required in version	Material	Part no.
1	1	CU41Nplus S AS-i extended cpl. (6x1)		PA6.6 GF30	H333120				
2	1	CU41Nplus S AS-i extended cpl. (1/4")		PA6.6 GF30	H333126				
3	1	CU41Nplus S AS-i extended cpl. (6x1) M12		PA6.6 GF30	H338855				
4	1	CU41Nplus S AS-i extended cpl. (1/4") M12		PA6.6 GF30	H338861				
5	1	CU41-Base	CU41	PA6.6 GF30	H319853				
6	1	CU4plus AS-i-SLD E-Modul	CU41	Zytel 70G33L	H333117				
7	1	CU4 Cover	CU41	PA12 Black	H325602				
8	1	Solenoid valve 1 EMV+NOT-element	CU41	PPS	H319951				
9	1	CU4plus Sensortower	CU41	Grlamid TR90	H321498				
10	1	O-ring 47.29 x 2.62	CU41	NBR	H320401				
11	4	Washer DIN125 A=3,7	CU41	A2	H323771				
12	4	Ejot Delta PT screw 35 x 14	CU41	A2	H320364				
13	1	CU4plus sensor cpl.	CU41		H324877				
14	3	Ejot Delta PT screw 30 x 10	CU41	A2	H320363				
15	3	Washer DIN9021 A=3,2	CU41	A2	H320404				
16	1	Pressure reducer valve 5 bar	CU41	Nickel-plated brass	H208841				
17	1	Connection direct automatic lock	CU41	Nickel-plated brass	H320551				
18	1	Elbow connector G1/8" 6x1	CU41	Nickel-plated brass	H208825				
19	1	Elbow connector G1/8" 1/4" OD	CU41 (1/4")	Nickel-plated brass	H312732				
20	1	Elbow connector G1/8" 6x1	CU41	Nickel-plated brass	H208825				
21	1	Elbow connector G1/8" 1/4" OD	CU41 (1/4")	Nickel-plated brass	H312732				
22	1	CU4 air filter	CU41	PE	H320223				
23	1	Sound reducer	CU41	Nickel-plated brass	H208826				
24	5	Ejot Delta PT screw 40 x 16	CU41	A2	H320365				
25	3	Washer DIN125 I=4,3	CU41	A2	H79576				
26	1	CU4 overflow valve	CU41	PPS	H320352				
27	1	O-ring 120.32 x 2.62	CU41	NBR	H320402				
28	1	Screwed cable gland M20x1.5 ø5-9	CU41	PA black	H320372				
29	1	Female Flange M12x1.5 - 4pin	CU41	1.4404	H338108				

CU4plus Adapter

Adapter Spareparts information to be found in document: RN01.044.3-1

Information contained in this document is subject to change without notice and does not represent a commitment on the part of SPX FLOW, Inc.. No part of this document may be reproduced or transmitted in any form or by any means, electronic or mechanical, including photocopying and recording, for any purpose, without the express written permission of SPX FLOW, Inc..

Spare parts list

Control Unit CU4 plus AS-i extended CU41plus-T AS-i ext.



Date:	04.04.24				
Name:	C. Keil				
Reviewed:	N. Spilthoff				
Date:				Page	4
Name:					9
Reviewed:					RN 01.044.6

SPX FLOW

pos. item	Quantity	Description, product contacted seals with reference number	required in version	Material	Part no.	Description, product contacted seals with reference number	required in version	Material	Part no.
		CU41plus T AS-i extended cpl. (6x1)		PA6.6 GF30	H333119				
		CU41plus T AS-i extended cpl. (1/4")		PA6.6 GF30	H333125				
		CU41plus T AS-i extended cpl. (6x1) M12		PA6.6 GF30	H338853				
		CU41plus T AS-i extended cpl. (1/4") M12		PA6.6 GF30	H338859				
1	1	CU41-Base	CU41	PA6.6 GF30	H319854				
2	1	CU4plus AS-i-SLD E-Modul	CU41	Zytel 70G33L	H333117				
3	1	CU4 Cover	CU41	PA12 Black	H325602				
4	1	Solenoid valve 1EMV	CU41	PPS	H319950				
7	1	CU4plus Sensortower	CU41	Grlamid TR90	H321498				
8	1	O-ring 47,29 x 2,62	CU41	NBR	H320401				
9	4	Washer DIN125 A=3,7	CU41	A2	H323771				
10	4	Ejot Delta PT screw 35 x 14	CU41	A2	H320364				
11	1	CU4plus sensor cpl.	CU41		H324877				
12	3	Ejot Delta PT screw 30 x 10	CU41	A2	H320363				
13	3	Washer DIN9021 A=3,2	CU41	A2	H320404				
16	1	Plug G1/8" with o-ring	CU41	Nickel-plated brass	H320482				
16.1	1	Plug G1/8" with o-ring	CU41	Nickel-plated brass	H320482				
17	1	Elbow connector G1/8" 6x1	CU41	Nickel-plated brass	H208825				
	1	Elbow connector G1/8" 1/4" OD	CU41 (1/4")	Nickel-plated brass	H312732				
18	1	CU4 air filter	CU41	PE	H320223				
19	1	Sound reducer	CU41	Nickel-plated brass	H208826				
20	5	Ejot Delta PT screw 40 x 16	CU41	A2	H320365				
21	3	Washer DIN125 I=4,3	CU41	A2	H79576				
22	1	CU4 overflow valve	CU41	PPS	H320352				
23	1	O-ring 120,32 x 2,62	CU41	NBR	H320402				
26	1	Screwed cable gland M20x1,5 ø5-9	CU41	PA black	H320372				
36	1	Female Flange M12x1.5 - 4pin	CU41	1.4404	H338108				

CU4plus Adapter

Adapter Spareparts information to be found in document: RN01.044.3-1

Information contained in this document is subject to change without notice and does not represent a commitment on the part of SPX FLOW, Inc.. No part of this document may be reproduced or transmitted in any form or by any means, electronic or mechanical, including photocopying and recording, for any purpose, without the express written permission of SPX FLOW, Inc..

Spare parts list

Control Unit CU4 plus AS-i extended CU41Nplus-T AS-i ext.



Date:	04.04.24				
Name:	C. Keil				
Reviewed:	N. Spilthoff				
Date:				Page	5
Name:					9
Reviewed:					RN 01.044.6

SPX FLOW

pos. item	Quantity	Description, product contacted seals with reference number	required in version	Material	Part no.
1	1	CU41Nplus T AS-i extended cpl. (6x1)	CU41	PA6.6 GF30	H333121
2	1	CU41Nplus T AS-i extended cpl. (1/4")	CU41	PA6.6 GF30	H333127
3	1	CU41Nplus T AIR/AIR AS-i ext.(6x1) M12	CU41	PA6.6 GF30	H338856
4	1	CU41Nplus T AIR/AIR AS-i ext.(1/4") M12	CU41	PA6.6 GF30	H338862
5	1	CU41-Base	CU41	PA6.6 GF30	H319854
6	1	CU4plus AS-i-SLD E-Modul	CU41	Zytel 70G33L	H333117
7	1	CU4 Cover	CU41	PA12 Black	H325602
8	1	Solenoid valve 1 EMV+NOT-element	CU41	PPS	H319951
9	1	CU4plus Sensortower	CU41	Grlamid TR90	H321498
10	1	O-ring 47,29 x 2,62	CU41	NBR	H320401
11	4	Washer DIN125 A=3,7	CU41	A2	H323771
12	4	Ejot Delta PT screw 35 x 14	CU41	A2	H320364
13	1	CU4plus sensor cpl.	CU41		H324877
14	3	Ejot Delta PT screw 30 x 10	CU41	A2	H320363
15	3	Washer DIN9021 A=3,2	CU41	A2	H320404
16	1	Pressure reducer valve 5 bar		Nickel-plated brass	H208841
17	1	Connection direct automatic lock		Nickel-plated brass	H320551
18	1	Plug G1/8" with o-ring	CU41	Nickel-plated brass	H320482
19	1	Elbow connector G1/8" 6x1	CU41	Nickel-plated brass	H208825
20	1	Elbow connector G1/8" 1/4" OD	CU41 (1/4")	Nickel-plated brass	H312732
21	1	CU4 air filter	CU41	PE	H320223
22	1	Sound reducer	CU41	Nickel-plated brass	H208826
23	5	Ejot Delta PT screw 40 x 16	CU41	A2	H320365
24	3	Washer DIN125 I=4,3	CU41	A2	H79576
25	1	CU4 overflow valve	CU41	PPS	H320352
26	1	O-ring 120,32 x 2,62	CU41	NBR	H320402
27	1	Screwed cable gland M20x1.5 ø5-9	CU41	PA black	H320372
28	1	Female Flange M12x1.5 - 4pin	CU41	1.4404	H338108

CU4plus Adapter

Adapter Spareparts information to be found in document: RN01.044.3-1

Information contained in this document is subject to change without notice and does not represent a commitment on the part of SPX FLOW, Inc.. No part of this document may be reproduced or transmitted in any form or by any means, electronic or mechanical, including photocopying and recording, for any purpose, without the express written permission of SPX FLOW, Inc..

Spare parts list

Control Unit CU4 plus AS-i extended CU4plus-M AS-i ext.



Date:	04.04.24				
Name:	C. Keil				
Reviewed:	N. Spieithoff				
Date:				Page	6
Name:					9
Reviewed:					RN 01.044.6

SPX FLOW

pos. item	Quantity	Description, product contacted seals with reference number	required in version	Material	Part no.	pos. item	Quantity	Description, product contacted seals with reference number	required in version	Material	Part no.
		CU43plus M AS-i ext. cpl. (6x1)		PA6.6 GF30	H333122	18	1	CU4 air filter	CU41+43	PE	H320223
		CU41plus M AS-i ext. cpl. (6x1)		PA6.6 GF30	H335237	19	1	Sound reducer	CU41+43	Nickel-plated brass	H208826
		CU43plus M AS-i ext. cpl. (6x1) M12		PA6.6 GF30	H338835	20	5	Ejot Delta PT screw 40 x 16	CU41+43	A2	H320365
		CU41plus M AS-i ext. cpl. (6x1) M12		PA6.6 GF30	H338854	21	3	Washer DIN125 I=4,3	CU41+43	A2	H79576
		CU43plus M AS-i ext. cpl. (1/4")		PA6.6 GF30	H333128	22	1	CU4 overflow valve	CU41+43	PPS	H320352
		CU41plus M AS-i ext. cpl. (1/4")		PA6.6 GF30	H335238	23	1	O-ring 120,32 x 2,62	CU41+43	NBR	H320402
		CU43plus M AS-i ext. cpl. (1/4") M12		PA6.6 GF30	H338836	24	2	Proximity switch Ni5 K1 1K-AN 5X/5			H208844
		CU41plus M AS-i ext. cpl. (1/4") M12		PA6.6 GF30	H338860	26	1	Screwed cable gland M20x1,5 ø5-9	CU41+43	PA black	H320372
1	1	CU41-Base	CU41	PA6.6 GF30	H319855	27	1	Screwed cable gland M20x1,5 ø2x5	CU43	PA black	H320371
		CU43-Base	CU43	PA6.6 GF30	H319857	36	1	Female Flange M12x1,5 - 4pin	CU41	1.4404	H338108
2	1	CU4plus AS-i-SLD E-Modul	CU41+43	Zytel 70G33L	H333117	40	1	CU4plus ada. Sensor 2 prox. Switches	CU43	PA black	H342435
3	1	CU4 Cover	CU41+43	PA12 Black	H325602						
4	1	Solenoid valve 1EMV	CU41	PPS	H319950						
6	1	Solenoid valve 3 EMV	CU43	PPS	H319952						
7	1	CU4plus Sensortower	CU41+43	Grlamid TR90	H321498						
8	1	O-ring 47,29 x 2,62	CU41+43	NBR	H320401						
9	4	Washer DIN125 A=3,7	CU41+43	A2	H323771						
10	4	Ejot Delta PT screw 35 x 14	CU41+43	A2	H320364						
11	1	CU4plus sensor cpl.	CU41+43		H324877						
12	3	Ejot Delta PT screw 30 x 10	CU41+43	A2	H320363						
13	3	Washer DIN9021 A=3,2	CU41+43	A2	H320404						
16.1	1	Plug G1/8" with o-ring	CU41	Nickel-plated brass	H320482						
17	1	Elbow connector G1/8" 6x1	CU41+43	Nickel-plated brass	H208825						
	1	Elbow connector G1/8" 1/4" OD	CU41+43	Nickel-plated brass	H312732						
	1	Elbow connector G1/8" 6x1	CU41+43	Nickel-plated brass	H208825						
17.1	1	Elbow connector G1/8" 1/4" OD	CU41+43	Nickel-plated brass	H312732						
	1	Elbow connector G1/8" 6x1	CU43	Nickel-plated brass	H208825						
17.2	1	Elbow connector G1/8" 1/4" OD	CU43	Nickel-plated brass	H312732						
	1	Elbow connector G1/8" 1/4" OD	CU43	Nickel-plated brass	H208825						
17.3	1	Elbow connector G1/8" 6x1	CU43	Nickel-plated brass	H208825						
	1	Elbow connector G1/8" 1/4" OD	CU43	Nickel-plated brass	H312732						

CU4plus Adapter

Adapter Spareparts information to be found in document: RN01.044.3-1

Information contained in this document is subject to change without notice and does not represent a commitment on the part of SPX FLOW, Inc.. No part of this document may be reproduced or transmitted in any form or by any means, electronic or mechanical, including photocopying and recording, for any purpose, without the express written permission of SPX FLOW, Inc..

Spare parts list

Control Unit CU4 plus AS-i extended CU4plus-D4 V2 AS-i ext.



Date:	04.04.24				
Name:	C. Keil				
Reviewed:	N. Spilthoff				
Date:				Page	7
Name:					9
Reviewed:					RN 01.044.6

SPX FLOW

pos. item	Quantity	Description, product contacted seals with reference number	required in version	Material	Part no.	pos. item	Quantity	Description, product contacted seals with reference number	required in version	Material	Part no.
1	1	CU41-Base	CU41	PA6.6 GF30	H319855	20	5	Ejot Delta PT screw 40 x 16	CU41+43	A2	H320365
	1	CU43-Base	CU43	PA6.6 GF30	H319857	21	3	Washer DIN125 I=4,3	CU41+43	A2	H79576
2	1	CU4plus AS-i-SLD E-Modul	CU41+43	Zytel 70G33L	H333117	22	1	CU4 overflow valve	CU41+43	PPS	H320352
3	1	CU4 Cover	CU41+43	PA12 Black	H325602	23	1	O-ring 120,32 x 2,62	CU41+43	NBR	H320402
4	1	Solenoid valve 1EMV	CU41	PPS	H319950	25	1	Plug V-NE-SD M20x1,5	CU41+43	PA black	H324895
6	1	Solenoid valve 3 EMV	CU43	PPS	H319952	26	1	Screwed cable gland M20x1,5 ø5-9	CU41+43	PA black	H320372
8	1	O-ring 47,29 x 2,62	CU41+43	NBR	H320401	33	1	CU4plus sensortower D4 V2	CU41+43	PET	H339461
9	4	Washer DIN125 A=3,7	CU41+43	A2	H323771	34	2	CU4plus Sensor V2	CU41+43	Noryl black	H339463
10	4	Ejot Delta PT screw 35 x 14	CU41+43	A2	H320364	35	1	Cap CU4plus sensor tower	CU41+43	Noryl black	H339432
12	6	Ejot Delta PT screw 30 x 10	CU41+43	A2	H320363	36	1	Flush-type connector M20x1,5	CU41+43	1.4404	H338108
13	3	Washer DIN9021 A=3,2	CU41+43	A2	H320404	CU4plus Adapter					
16.1	1	Plug G1/8" with o-ring	CU41	Nickel-plated brass	H320482						
17	1	Elbow connector G1/8" 6x1	CU41+43	Nickel-plated brass	H208825						
	1	Elbow connector G1/8" 1/4" OD	CU41+43	Nickel-plated brass	H312732						
17.1	1	Elbow connector G1/8" 6x1	CU41+43	Nickel-plated brass	H208825						
	1	Elbow connector G1/8" 1/4" OD	CU41+43	Nickel-plated brass	H312732						
17.2	1	Elbow connector G1/8" 6x1	CU43	Nickel-plated brass	H208825						
	1	Elbow connector G1/8" 1/4" OD	CU43	Nickel-plated brass	H312732						
17.3	1	Elbow connector G1/8" 6x1	CU43	Nickel-plated brass	H208825						
	1	Elbow connector G1/8" 1/4" OD	CU43	Nickel-plated brass	H312732						
18	1	CU4 air filter	CU41+43	PE	H320223						
19	1	Sound reducer	CU41+43	Nickel-plated brass	H208826						

Adapter Spareparts information to be found in document: RN01.044.3-1

Information contained in this document is subject to change without notice and does not represent a commitment on the part of SPX FLOW, Inc.. No part of this document may be reproduced or transmitted in any form or by any means, electronic or mechanical, including photocopying and recording, for any purpose, without the express written permission of SPX FLOW, Inc..

Spare parts list

Control Unit CU4 plus AS-i extended CU4plus-DT4 AS-i ext.



Date:	04.04.24				
Name:	C. Keil				
Reviewed:	N. Spilthoff				
Date:				Page	8
Name:					9
Reviewed:					RN 01.044.6

SPX FLOW

pos. item	Quantity	Description, product contacted seals with reference number	required in version	Material	Part no.	pos. item	Quantity	Description, product contacted seals with reference number	required in version	Material	Part no.
		CU43plus DT4 AS-i ext. V2 (6x1)		PA6.6 GF30	H342423	36	1	Flush-type connector M20x1,5	CU43	1.4404	H338108
		CU43plus DT4 AS-i ext. V2 (1/4")		PA6.6 GF30	H342424	37	1	Screwed cable gland M20x1,5 ø5-9mm	CU43	PA black	H320372
		CU43plus DT4 AS-i ext. V2 (6x1) M12		PA6.6 GF30	H342421	38	1	Balluff linear sensor	CU43		H343141
		CU43plus DT4 AS-i ext. V2 (1/4") M12		PA6.6 GF30	H342422	39	1	CU4plus Adapter Sensor 0-10V	CU43		H342434
						41	1	Cable grommet	CU43	PVC black	H344059
						42	1	O-ring	CU43	NBR	H336024
						43	1	CU4plus pressure sensor cpl.	CU43		H336026
1	1	CU43-Base	CU43	PA6.6 GF30	H319857						
2	1	CU4plus AS-i-SLD E-Modul	CU43	Zytel 70G33L	H333117						
3	1	CU4 Cover	CU43	PA12 Black	H325602						
6	1	Solenoid valve 3 EMV	CU43	PPS	H319952						
7	1	CU4plus Sensortower	CU43	Grlamid TR90	H321498						
8	1	O-ring	CU43	NBR	H320401						
9	4	Washer	CU43	A2	H323771						
10	4	Ejot Delta PT screw	CU43	A2	H320364						
11	1	CU4plus sensor cpl.	CU43		H324877						
12	5	Ejot Delta PT screw	CU43	A2	H320363						
13	3	Washer	CU43	A2	H320404						
17	1	Elbow connector G1/8" 6x1	CU43	Nickel-plated brass	H208825						
	1	Elbow connector G1/8" 1/4" OD	CU43	Nickel-plated brass	H312732						
17.1	1	Elbow connector G1/8" 6x1	CU43	Nickel-plated brass	H208825						
	1	Elbow connector G1/8" 1/4" OD	CU43	Nickel-plated brass	H312732						
17.2	1	Elbow connector G1/8" 6x1	CU43	Nickel-plated brass	H208825						
	1	Elbow connector G1/8" 1/4" OD	CU43	Nickel-plated brass	H312732						
17.3	1	Elbow connector G1/8" 6x1	CU43	Nickel-plated brass	H208825						
	1	Elbow connector G1/8" 1/4" OD	CU43	Nickel-plated brass	H312732						
18	1	CU4 air filter	CU43	PE	H320223						
19	1	Sound reducer	CU43	Nickel-plated brass	H208826						
20	5	Ejot Delta PT screw	CU43	A2	H320365						
21	3	Washer	CU43	A2	H79576						
22	1	CU4 overflow valve	CU43	PPS	H320352						
23	1	O-ring	CU43	NBR	H320402						
26	1	Screwed cable gland M20x1,5 ø5-9	CU43	PA black	H320372						

CU4plus Adapter

Adapter Spareparts information to be found in document: RN01.044.3-1

Information contained in this document is subject to change without notice and does not represent a commitment on the part of SPX FLOW, Inc.. No part of this document may be reproduced or transmitted in any form or by any means, electronic or mechanical, including photocopying and recording, for any purpose, without the express written permission of SPX FLOW, Inc..

Spare parts list

Control Unit CU4 plus AS-i extended CU4plus-AM1 AS-i ext.



Date:	04.04.24				
Name:	C. Keil				
Reviewed:	N. Spilthoff				
Date:				Page	9
Name:					
Reviewed:					RN 01.044.6

SPX FLOW

pos. item	Quantity	Description, product contacted seals with reference number	required in version	Material	Part no.	pos. item	Quantity	Description, product contacted seals with reference number	required in version	Material	Part no.
		CU43plus AM1 AS-i ext. V2 (6x1)		PA6.6 GF30	H348709	36	1	Flush-type connector M20x1,5	CU43	1.4404	H338108
		CU43plus AM1 AS-i ext. V2 (1/4")		PA6.6 GF30	H348714	37	1	Screwed cable gland M20x1,5 ø5-9mm	CU43	PA black	H320372
		CU43plus AM1 AS-i ext. V2 (6x1) M12		PA6.6 GF30	H348033	38	1	Balluff linear sensor	CU43		H343141
		CU43plus AM1 AS-i ext. V2 (1/4") M12		PA6.6 GF30	H348715	39	1	CU4plus Adapter Sensor 0-10V	CU43		H342434
						41	1	Cable grommet	CU43	PVC black	H344059
						42	1	O-ring	CU43	NBR	H336024
						43	1	CU4plus pressure sensor cpl.	CU43		H336026
1	1	CU43-Base	CU43	PA6.6 GF30	H319857						
2	1	CU4plus AS-i-SLD E-Modul	CU43	Zytel 70G33L	H333117						
3	1	CU4 Cover	CU43	PA12 Black	H325602						
6	1	Solenoid valve 3 EMV	CU43	PPS	H319952						
7	1	CU4plus Sensortower	CU43	Grlamid TR90	H321498						
8	1	O-ring	CU43	NBR	H320401						
9	4	Washer	CU43	A2	H323771						
10	4	Ejot Delta PT screw	CU43	A2	H320364						
11	1	CU4plus sensor cpl.	CU43		H324877						
12	5	Ejot Delta PT screw	CU43	A2	H320363						
13	3	Washer	CU43	A2	H320404						
17	1	Elbow connector G1/8" 6x1	CU43	Nickel-plated brass	H208825						
	1	Elbow connector G1/8" 1/4" OD	CU43	Nickel-plated brass	H312732						
17.1	1	Elbow connector G1/8" 6x1	CU43	Nickel-plated brass	H208825						
	1	Elbow connector G1/8" 1/4" OD	CU43	Nickel-plated brass	H312732						
17.2	1	Elbow connector G1/8" 6x1	CU43	Nickel-plated brass	H208825						
	1	Elbow connector G1/8" 1/4" OD	CU43	Nickel-plated brass	H312732						
17.3	1	Elbow connector G1/8" 6x1	CU43	Nickel-plated brass	H208825						
	1	Elbow connector G1/8" 1/4" OD	CU43	Nickel-plated brass	H312732						
18	1	CU4 air filter	CU43	PE	H320223						
19	1	Sound reducer	CU43	Nickel-plated brass	H208826						
20	5	Ejot Delta PT screw	CU43	A2	H320365						
21	3	Washer	CU43	A2	H79576						
22	1	CU4 overflow valve	CU43	PPS	H320352						
23	1	O-ring	CU43	NBR	H320402						
26	1	Screwed cable gland M20x1,5 ø5-9	CU43	PA black	H320372						

CU4plus Adapter

Adapter Spareparts information to be found in document: RN01.044.3-1

Date:	19.04.24	19.12.24
Name:	C.Keil	C.Keil
Reviewed:	N.Spl	N.Spl

Control Unit CU4 plus Adapter

RN 01.044.3-1

Date:		
Name:		
Reviewed:		

CU4Plus D4 Adapter

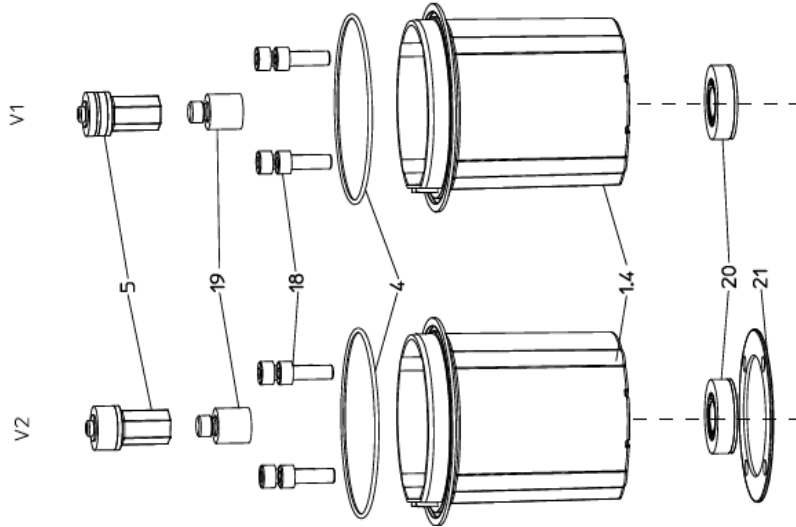

CU4Plus M - Adapter

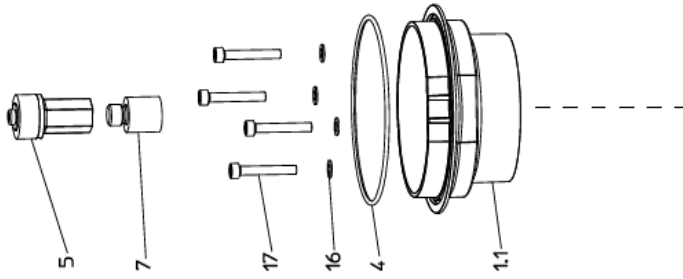

CU4Plus T - Adapter

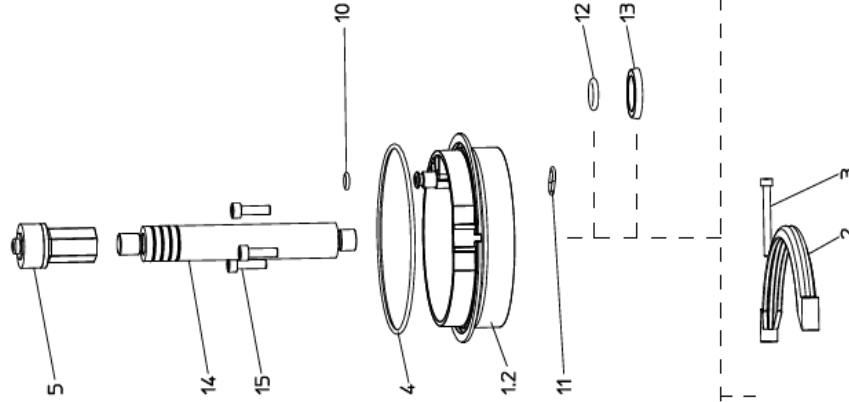

CU4Plus S - Adapter

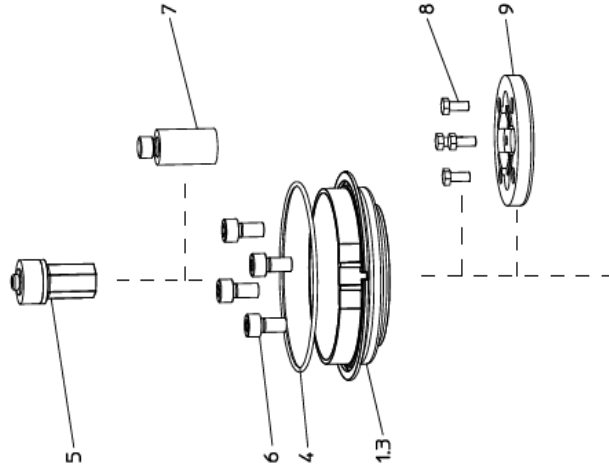

Information contained in this document is subject to change without notice and does not represent a commitment on the part of SPX FLOW, Inc.. No part of this document may be reproduced or transmitted in any form or by any means, electronic or mechanical, including photocopying and recording, for any purpose, without the express written permission of SPX FLOW, Inc..

Spare Parts list

Control Unit CU4 plus Adapter

Date: 19.04.24
 Name: C.Keil
 Reviewed: N.Spl

SPX FLOW

Page 2 of 8

RN 01.044.3-1

CU4plus DT4-62 / AM1 Adapter

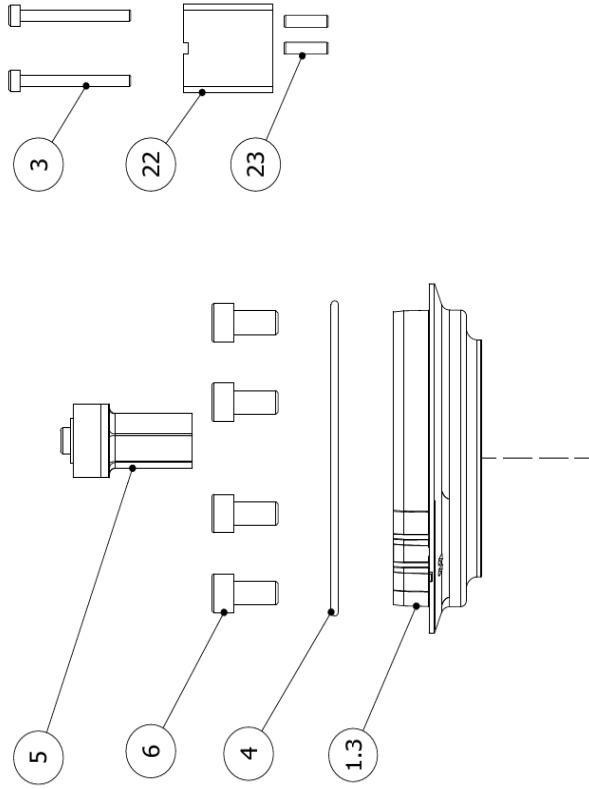

CU4plus DT4-92 Adapter

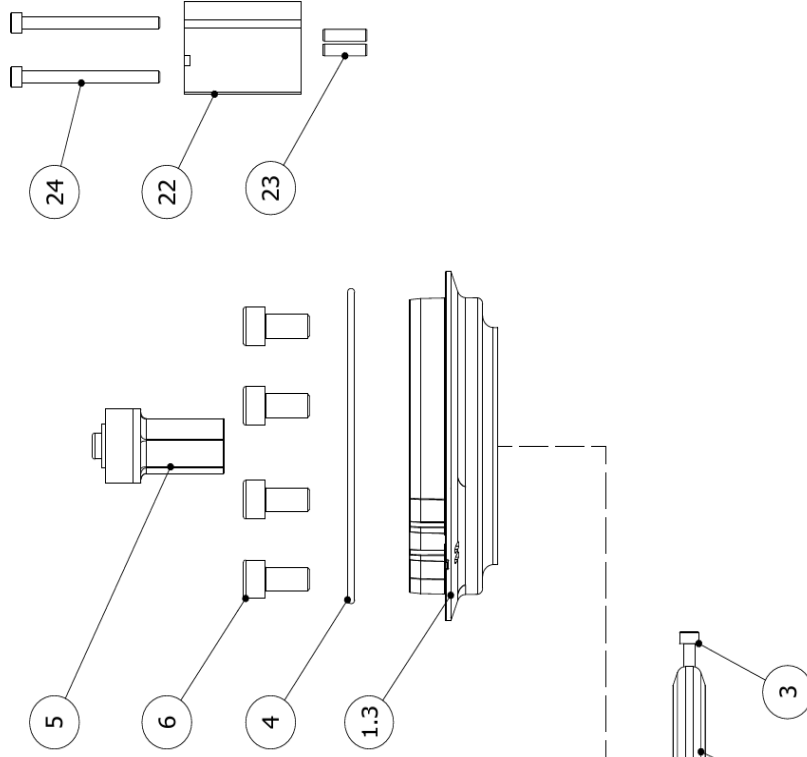

Information contained in this document is subject to change without notice and does not represent a commitment on the part of SPX FLOW, Inc.. No part of this document may be reproduced or transmitted in any form or by any means, electronic or mechanical, including photocopying and recording, for any purpose, without the express written permission of SPX FLOW, Inc..

Spare parts list

Control Unit CU4 plus Adapter CU4plus-S / CU4plus-S Longstroke

Date: 19.04.24			
Name: C.Keil			
Reviewed: N.Spl			
SPX FLOW			
Date:		Page 3	8
Name:		RN 01.044.3-1	
Reviewed:			

pos. item	Quantity	Description	required in version	Material	Part no.
		CU4 S Longstroke Ø165 adapter cpl.	S-Longstroke		H335312
1.3	1	CU4 adapter S	S-Longstroke	Zytel 70G33L	H319874
2	2	CU4 clamp cpl.	S-Longstroke	Grivory	H319873
3	2	Cylinder Screw M4x40	S-Longstroke	A2-70	H320360
4	1	O-Ring 101,27x2,62	S-Longstroke	NBR	H148389
5	1	CU4 magnet cpl.	S-Longstroke	Zytel 70G33L	H333099
6	4	Cylinder Screw M8x25	S-Longstroke	A2-70	H79014
9	1	CU adapter SW4	S-Longstroke	PA6	H330879

pos. item	Quantity	Description	required in version	Material	Part no.
		CU4 S adapter cpl.	S		H333143
1.3	1	CU4 adapter S	S	Zytel 70G33L	H319874
2	2	CU4 clamp cpl.	S	Grivory	H319873
3	2	Cylinder Screw M4x40	S	A2-70	H320360
4	1	O-Ring 101,27x2,62	S	NBR	H148389
5	1	CU4 magnet cpl.	S	Zytel 70G33L	H333099
6	4	Cylinder Screw M8x16	S	A2-70	H79012

Information contained in this document is subject to change without notice and does not represent a commitment on the part of SPX FLOW, Inc.. No part of this document may be reproduced or transmitted in any form or by any means, electronic or mechanical, including photocopying and recording, for any purpose, without the express written permission of SPX FLOW, Inc..

Spare parts list

Control Unit CU4 plus Adapter CU41plus-M / CU43plus-M

Date: 19.04.24
 Name: C.Keil
 Reviewed: N.Spl
 Date:
 Name:
 Reviewed:
 Page 6
 8
 RN 01.044.3-1

SPX FLOW

pos. item	Quantity	Description	required in version	Material	Part no.
		CU41 M adapter cpl.	41 M		H320476
1.1	1	CU4 adapter M	41 M	Zytel 70G33L	H319876
2	2	CU4 clamp cpl.	41 M	Grivory	H319873
3	2	Cylinder Screw	41 M	A2-70	H320360
4	1	O-Ring	41 M	NBR	H148389
16	4	Washer	41 M	A2-70	H208842
17	4	Cylinder Screw	41 M	A2-70	H79028

pos. item	Quantity	Description	required in version	Material	Part no.
		CU43 M adapter cpl.	43 M		H333148
1.1	1	CU4 adapter M	43 M	Zytel 70G33L	H319876
2	2	CU4 clamp cpl.	43 M	Grivory	H319873
3	2	Cylinder Screw	43 M	A2-70	H320360
4	1	O-Ring	43 M	NBR	H148389
5	1	CU4 magnet switch cam cpl.	43 M	Zytel 70G33L	H333099
7	1	Guide rod extension	43 M	PA6	H333136
16	4	Washer	43 M	A2-70	H208842
17	4	Cylinder Screw	43 M	A2-70	H79028

Information contained in this document is subject to change without notice and does not represent a commitment on the part of SPX FLOW, Inc.. No part of this document may be reproduced or transmitted in any form or by any means, electronic or mechanical, including photocopying and recording, for any purpose, without the express written permission of SPX FLOW, Inc..

Spare parts list

**Control Unit CU4 plus Adapter
CU4plus-D4 V2 / CU4plus-D4 V2**

Date:	19.04.24	19.12.24	SPX FLOW	
Name:	C.Keil	C.Keil		
Reviewed:	N.Spl	N.Spl		
Date:			Page	7
Name:			RN 01.044.3-1	
Reviewed:				

pos. item	Quantity	Description	required in version	Material	Part no.
		CU4 D4 V1 adapter cpl.	D4 V1		H336441
1.4	1	CU4 adapter D4	D4 V1	Zytel 70G33L	H336038
2	2	CU4 clamp cpl.	D4 V1	Grivory	H319873
3	2	Cylinder Screw M4x40	D4 V1	A2-70	H320360
4	1	O-Ring 101,27x2,62	D4 V1	NBR	H148389
5	1	CU4 magnet switch cam cpl.	D4 V1	Zytel	H320479
18	4	Cylinder screw	D4 V1	A2-70	H79014
19	1	D4 guide rod adapter for CU4	D4 V1	PA6.6	H336934
20	1	D4 magnet CU4plus cpl.	D4 V1		H348519

pos. item	Quantity	Description	required in version	Material	Part no.
		CU4 D4 V2 adapter cpl.	D4 V2		H341891
1.4	1	CU4 adapter D4	D4 V2	Zytel 70G33L	H336038
2	2	CU4 clamp cpl.	D4 V2	Grivory	H319873
3	2	Cylinder Screw M4x40	D4 V2	A2-70	H320360
4	1	O-Ring 101,27x2,62	D4 V2	NBR	H148389
5	1	CU4plus magnet switch cam cpl.	D4 V2	Zytel	H333099
18	4	Cylinder screw	D4 V2	A2-70	H173568
19	1	D4 guide rod adapter for CU4	D4 V2	PA6.6	H336934
20	1	D4 magnet CU4plus cpl.	D4 V2		H348519
21	1	CU4plus V2 distance washer	D4 V2	NBR	H342644

Information contained in this document is subject to change without notice and does not represent a commitment on the part of SPX FLOW, Inc.. No part of this document may be reproduced or transmitted in any form or by any means, electronic or mechanical, including photocopying and recording, for any purpose, without the express written permission of SPX FLOW, Inc..

Spare parts list

**Control Unit CU4 plus Adapter
CU4plus-DT4 62 / CU4plus-DT 92 / CU4plus AM1**

Date: 19.04.24
 Name: C.Keil
 Reviewed: N.Spl

SPX FLOW

Page 8
 RN 01.044.3-1

pos. item	Quantity	Description	required in version	Material	Part no.
		CU4 DT4-62 adapter cpl.	DT4 62 / AM1		H343619
1.3	1	CU4 adapter S	DT4 62 / AM1	Zytel 70G33L	H319874
2	2	CU4 clamp cpl.	DT4 62 / AM1	Grivory	H319873
3	4	Cylinder Screw	DT4 62 / AM1	A2-70	H320360
4	1	O-Ring	DT4 62 / AM1	NBR	H148389
5	1	CU4 magnet switch cam cpl.	DT4 62 / AM1	Zytel	H333099
6	1	Cylinder screw	DT4 62 / AM1	A2-70	H79012
22	1	Balluf adapter-62	DT4 62 / AM1	PA6.6	H342080
23	2	Parallel pin	DT4 62 / AM1	A1	H343581

pos. item	Quantity	Description	required in version	Material	Part no.
		CU4 DT4-92 adapter cpl.	DT4 92		H343620
1.3	1	CU4 adapter S	DT4 92	Zytel 70G33L	H319874
2	2	CU4 clamp cpl.	DT4 92	Grivory	H319873
3	2	Cylinder Screw	DT4 92	A2-70	H320360
4	1	O-Ring	DT4 92	NBR	H148389
5	1	CU4plus magnet switch cam cpl.	DT4 92	Zytel	H333099
6	1	Cylinder screw	DT4 92	A2-70	H79012
22	1	Balluf adapter-92	DT4 62	PA6.6	H343618
23	2	Parallel pin	DT4 62	A2-70	H343581
24	2	Cylinder screw	DT4 62	A2-70	H343617

CU4plus AS-interface V1 - V2

CONTROL UNIT



SPX FLOW

Design Center

Gottlieb-Daimler-Straße 13
D-59439 Holzwickede, Germany
P: (+49) (0) 2301-9186-0
F: (+49) (0) 2301-9186-300

SPX FLOW, Inc.

Production

611 Sugar Creek Road
Delavan, WI 53115, USA
P: (+1) 262 728 1900 or (800) 252 5200
F: (+1) 262 728 4904 or (800) 252 5012
E: wcb@spxflow.com

SPX FLOW

Production

Stanisława Jana Rolbieskiego 2
PL- Bydgoszcz 85-862, Poland
P: (+48) 52 566 76 00
F: (+48) 52 525 99 09

SPX FLOW reserves the right to incorporate the latest design and material changes without notice or obligation.

Design features, materials of construction and dimensional data, as described in this manual, are provided for your information only and should not be relied upon unless confirmed in writing. Please contact your local sales representative for product availability in your region.

For more information visit www.spxflow.com.

The green ">" is a trademark of SPX FLOW, Inc.

ISSUED 03/2021 - Original Manual

COPYRIGHT ©2021 SPX FLOW, Inc.