

Gerstenberg Schröder Perfector 125

SCRAPED SURFACE HEAT EXCHANGER

GS Perfector 125 Benefits:

OUTSTANDING DURABILITY

Completely sealed, fully insulated, corrosion-free stainless steel casing guarantees years of trouble-free operation.

IMPROVED HEAT TRANSMISSION

Special, corrugated chilling tubes improve the heat transmission value and prevent any internal build-up of compressor oil.

HIGHER EFFICIENCY

Each refrigerant circuit has a drop tank that enables prompt start-up and reduces downtime during production halts.

EASY CLEANING AND MAINTENANCE

GS Perfector 125 is designed to keep downtime to an absolute minimum - CIP cycles are fast and efficient, and maintenance procedures are simple.

LESS NOISE

The low energy, cast iron gear box yields maximum power while keeping noise levels to a minimum.

SCRAPER ROTOR SYSTEM

The standard scraper system is the Bulldog system featuring two rows of plastic scrapers. The scrapers can be inspected and replaced without removing the rotor. This ensures less downtime. Alternatively, rotor systems with floating scrapers in a selection of different materials are available to suit your particular product application.



PRODUCT SEALS

The product seals are designed to be semi-balanced with tungsten carbide wearing rings. Flushed seals are also available.

MATERIALS

Product contacting parts are made in stainless steel AISI 316. Chilling tubes are made in carbon steel plated with hard chromium. Alternatively, other materials are available on request.

CERTIFICATIONS

Made in conformity with European Machinery Directive 2006/42/EC. The construction is in accordance with European Pressure Equipment Directive (PED) 2014/68/EU and an ASME sec. VIII div. 1 certificate can be delivered on request.

COOLING MEDIA

NH₃, freon.

GS PERFECTOR 125	1 x 125	2 x 125	(1+1) x 125	(2+2) x 125	(1+1+1+1) x 125	(1+1+2) x 125	(2+2+2) x 125
NOMINAL CAPACITY - PUFF PASTRY MARGARINE [KG/H]	NA	750	750	1,500	1,500	1,500	2,250
NOMINAL CAPACITY - TABLE MARGARINE [KG/H]	750	1,500	1,500	3,000	3,000	3,000	4,500
NOMINAL CAPACITY - SHORTENING [KG/H]	1,100	2,200	2,200	4,400	4,400	4,400	6,600
NUMBER OF REFRIGERANT CIRCUITS	1	1	2	2	4	3	3
NUMBER OF TUBES PER REFRIGERANT CIRCUIT	1	2	1	2	1	1+2	2
MOTORS FOR PUFF PASTRY MARGARINE [kW]	22	37	11+22	22+45	11+11+22+22	15+15+45	22+45+45
MOTORS FOR TABLE MARGARINE [kW]	15	30	11+15	22+30	11+11+15+15	15+15+30	22+30+30
MOTORS FOR SHORTENING [kW]	15	30	11+15	22+30	11+11+15+15	15+15+30	22+30+30
NUMBER OF GEAR BOXES	1	1	2	2	4	3	3
COOLING SURFACE PER TUBE [M ²]	0.42	0.42	0.42	0.42	0.42	0.42	0.42
ANNULAR SPACE [MM]	6	6	6	6	6	6	6
NH ₃ CAPACITY AT -20°C [kW]	30/35	50/60/70	50/60/70	100/120/140	100/120/140	100/120/140	150/180/210
MAX. WORKING PRESSURE AT 40°C - MEDIA SIDE [BAR]	17.5	17.5	17.5	17.5	17.5	17.5	17.5
MAX. WORKING PRESSURE - PRODUCT SIDE [BAR]	120	120	120	120	120	120	120
MIN. WORKING TEMPERATURE - MEDIA SIDE [°C]	-25	-25	-25	-25	-25	-25	-25
CHILLING TUBE DIAMETER/ LENGTH [MM]	125/1,135	125/1,135	125/1,135	125/1,135	125/1,135	125/1,135	125/1,135
PRODUCT VOLUME PER TUBE [L]	3.5	3.5	3.5	3.5	3.5	3.5	3.5
PRODUCT PIPE IN/OUT [MM]	32x1.2	32x1.2	32x1.2	32x1.2	32x1.2	32x1.2	32x1.2
ROWS OF SCRAPERS	2	2	2	2	2	2	2
NOMINAL SCRAPER ROTOR SPEED [RPM]	490	490	490	490	490	490	490
WATER ATTEMPERATION CAPACITY [kW]	7.5	7.5	7.5	15	15	15	15+15
WATER ATTEMPERATION VOLUME [L]	45	45	45	45	45	45	45
WATER CIRCULATION PUMP [kW]	0.25	0.25	0.25	0.25	0.25	0.25	0.25
MACHINE WEIGHT [KG]*	1,400	1,600	2,000	3,100	3,500	3,300	4,400

* Approximately.

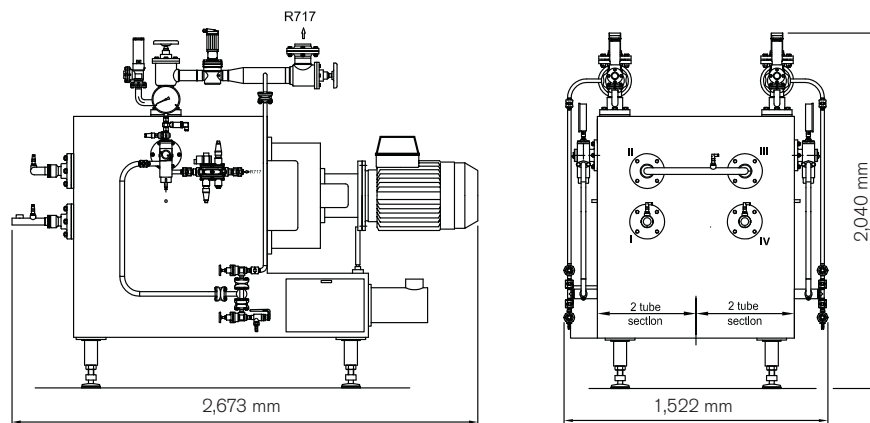

GS Perfector (2+2) x 125

SPXFLOW

SPX FLOW Oestmarken 7, 2860 Soeborg, Denmark

P: +45 70 278 222, F: +45 70 278 223

E: gs.dk.sales@spxflow.com · www.spxflow.com

SPX FLOW reserves the right to incorporate our latest design and material changes without notice or obligation. Design features, materials of construction and dimensional data, as described in this bulletin, are provided for your information only and should not be relied upon unless confirmed in writing. Please contact your local sales representative for product availability in your region. For more information visit www.spxflow.com. The green ">" is a trademark of SPX FLOW, Inc.

GS-202-GB VERSION 03/2016 ISSUED 01/2017

COPYRIGHT © 2016 SPX FLOW, Inc.