

DW Pump

ROTARY LOBE PUMPS

FORM NO.: L453194UK REVISION: 12/2012

READ AND UNDERSTAND THIS MANUAL PRIOR TO OPERATING OR SERVICING THIS PRODUCT.

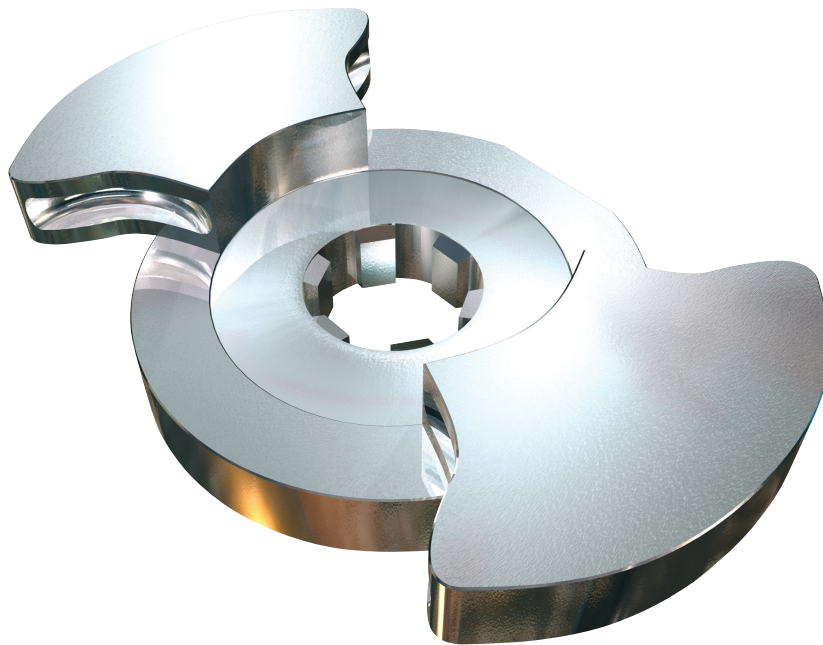

7. Pumpe komplet / Pump complete

Std. DW 1

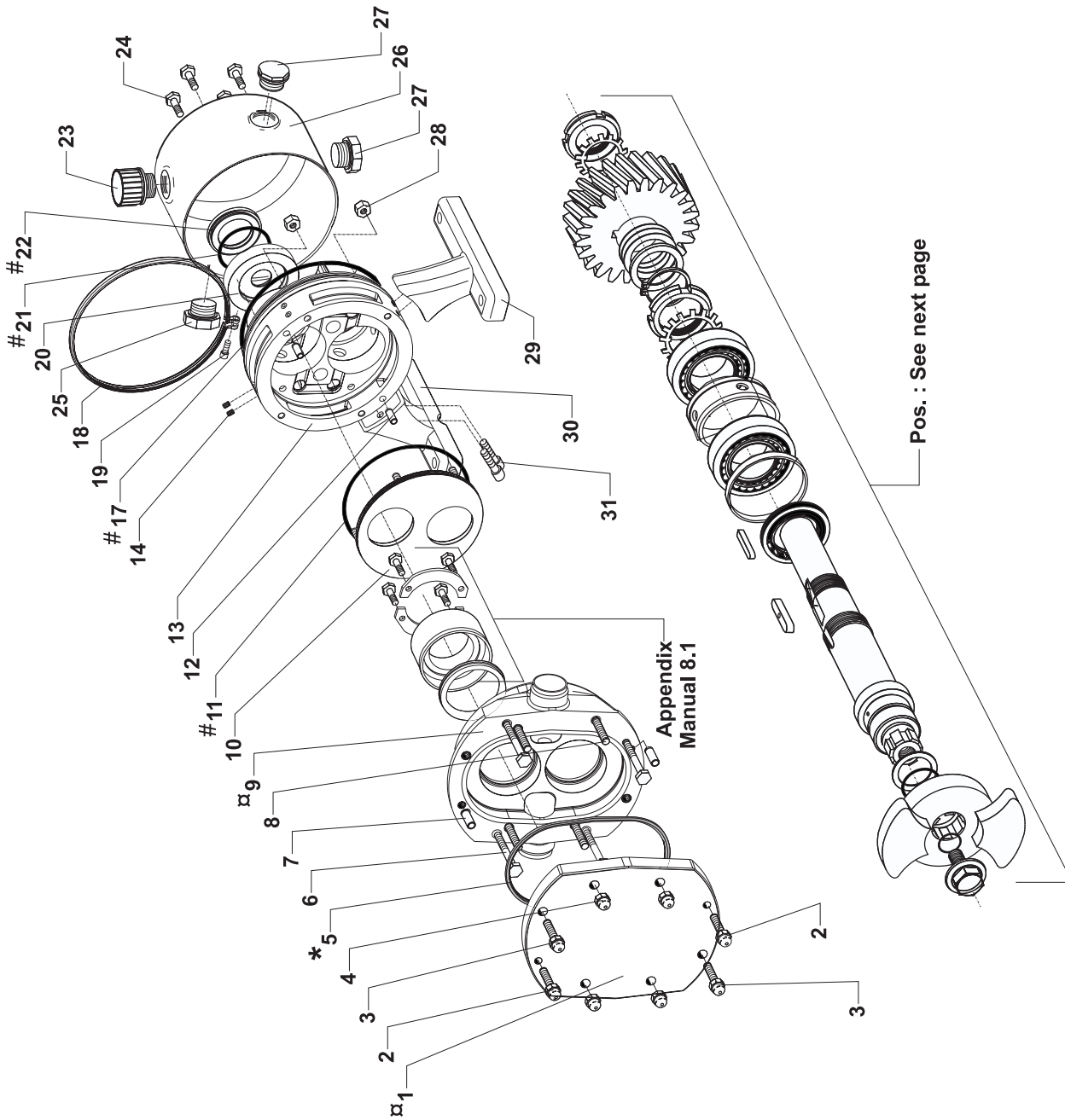

- * Produkt berørt paknings kit / Wet end seal kit
- # Gear boks paknings kit / Gear box seal kit

7. Pumpe komplet / Pump complete

Std. DW 1

NB! Nedenstående α varenumre, dækker ikke pumper solgt med 3.1 certifikat.
 For 3.1 reservedele, kontakt APV.
 α Part No. mentioned below, do not cover pumps sold with 3.1 certificate.
 For 3.1 spare parts, contact APV.

Pos	Stk/Qty	Material	Benævnelse	Description	Del nr. / Part No.			
					Piston	Lobe	Lobe	Lobe
					DW1/0037.5	DW1/004/15	DW1/007/7	DW1/007/15_600
α 1	1	316L	Frontdæksel	Front cover	LA1110101	LA1110100	LA1110100	LA1110100
2	2	304S.S	Stor bolt, front plade	Big bolt, front cover	LA1000100	LA1000100	LA1000100	LA1000100
3	2	304S.S	Lille bolt, front plade	Small bolt, front cover	LA1001200	LA1001200	LA1001200	LA1001200
4	4	AISI 304	Møtrik, frontplade	Nut, front cover dome	L700243	L700243	L700243	L700243
6	4	304S.S	Skruer, rotorhus/ lejekonsol	Screw, rotor case to chassis	L773450	L773450	L773452	L773452
7	2	316S.S	Styrestift	Dowel	LA1160320	LA1002100	LA1002100	LA1002100
8	4	AISI 304	Støttebolt, frontplade	Stud, front cover	LA1002100	LA1002100	LA1002100	LA1002100
α 9	1	316L	Rotorhus	Rotor case	LA17991003	LA17991003	LA17991007	LA17991007
10	1	304S.S.	Olietætningsplade	Oil seat plate	LA1312100	LA1312100	LA1312100	LA1312100
12	2	316S.S	Styrestift, rotorhus/ lejekonsol	Dowel, rotor case to chassis	LA1160320	LA1160320	LA1160320	LA1160320
13	1	1. 4305	Lejekonsol	Chassis	LA1302100	LA1302100	LA1302100	LA1302100
14	4	304S.S	Blindskruer	Plug	LA2000100	LA2000100	LA2000100	LA2000100
18	1	304S.S	Clampring	Clamp ring	LA1354100	LA1354100	LA1354100	LA1354100
19	1	304S.S	Skruer for clampring	Screw for clampring	L772962	L772962	L772962	L772962
20	1	Brass	Holder for læbetætning	Seal consol	LA1301100	LA1301100	LA1301100	LA1301100
23	1	Plastic	Oliepåfyldningsstuds	Oil filler plug	L2202000	L2202000	L2202000	L2202000
24	4	304S.S.	Skruer, holder for læbetætning	Screw, seal consol	L701517	L701517	L701517	L701517
25	1	Plastic	Olieskueglas	Oil level window	L2220000	L2220000	L2220000	L2220000
26	1	304S.S	Tandhjulskappe	Can	LA1364100	LA1364100	LA1364100	LA1364100
27	2	Plastic	Oliedrænprop	Oil drain plug	L2210A000	L2210A000	L2210A000	L2210A000
28	4	304S.S.	Klemmelemøtrik, olietætningsplade	Nut, oil seal plate	L773649	L773649	L773649	L773649
29 & 30	1	304S.S	Fødder (1 par)	Feet (1 pair)	LA1145100	LA1145100	LA1145100	LA1145100
31	4	304S.S	Skruer for fod	Screw for foot	L701057	L701057	L701057	L701057
* 5, 34 & 36	1	EPDM	Produktberørt paknings kit	Wet end seal kit	LA2380104	LA2380104	LA2380104	LA2380104
-	1	FPM (Viton)	Produktberørt paknings kit	Wet end seal kit	LA2380102	LA2380102	LA2380102	LA2380102
-	1	ISOLAST	Produktberørt paknings kit	Wet end seal kit	LA2380115	LA2380115	LA2380115	LA2380115
#11, 17, 21, 22 & 42	1	FPM (Viton)	Gear boks paknings kit	Gear box seal kit	LA2381102	LA2381102	LA2381102	LA2381102

7. Pumpe komplet / Pump complete

Std. DW 1

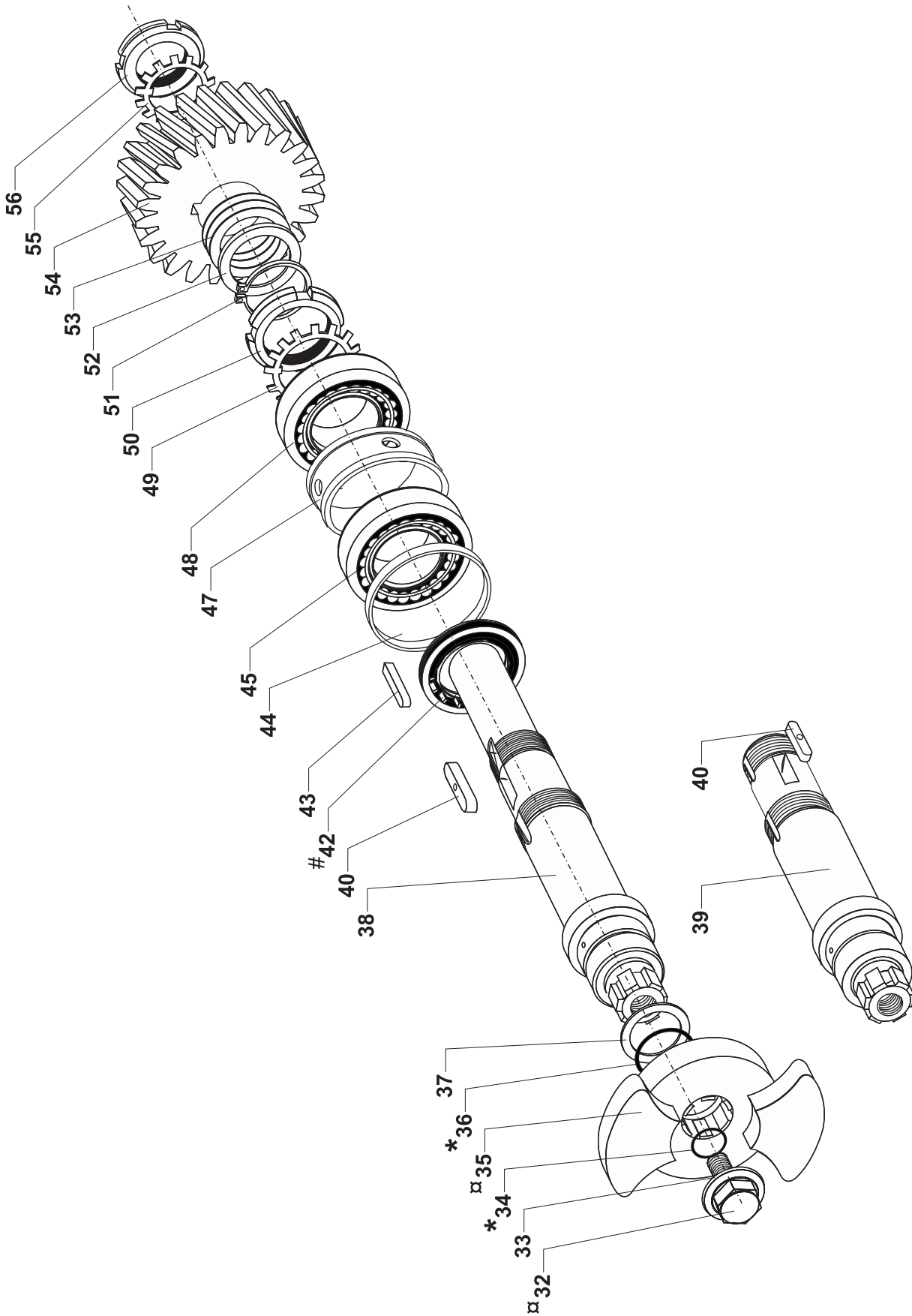

* Produkt berørt paknings kit / Wet end seal kit
 # Gear boks paknings kit / Gear box seal kit

7. Pumpe komplet / Pump complete

Std. DW 1

NBI! Nedenstående α varenumre, dækker ikke pumper solgt med 3.1 certifikat.
 For 3.1 reservedele, kontakt APV.
 α Part No. mentioned below, do not cover pumps sold with 3.1 certificate.
 For 3.1 spare parts, contact APV.

Pos	Stk/Qty	Material	Benævnelse	Description	Del nr. / Part No.			
					Piston DW1/0037/5	Lobe DW1/004/15	Lobe DW1/007/7	Lobe DW1/007/15_600
α 32	2	329S.S	Rotor skrue incl friktionsring	Rotor Screw with washer	LA10501003	LA10501004	LA10501006	LA105010061
33	2	18/02	Friktionsring	Washer ring	LA2658100	LA2658100	LA2658100	LA2658100
α 35	2	316L	Rotor-høj virkningsgrad	Rotor-high efficiency	LA141003P2SH	LA14100421SH	LA14100721SH	LA14100723SH
-	2	316L	Rotor-Multi-Duty	Rotor-Multi-Duty	LA141003P3SH	LA14100423SH	LA14100723SH	LA14100723SH
-	2	316L	Rotor-høj temperatur	Rotor-high temperature	LA141003P1SY	LA14100421SY	LA14100721SY	LA14100721SY
-	2	NGA	Rotor-høj virkningsgrad	Rotor-high efficiency	LA141003P4WH	LA14100424WH	LA14100724WH	LA14100724WH
-	2	NGA	Rotor høj temperatur	Rotor-high temperature	LA141003P5WH	LA14100424WY	LA14100724WY	LA14100724WY
-	2	NGA	Rotor-super tight	Rotor-super tight	LA141003P5WH	LA14100425WH	LA14100725WH	LA14100725WH
37	1	316S.S	Afstandskiver, rotor	Shims, rotor	L2657100	L2657100	L2657100	L2657100
38	1	AISI329L	Drivaksel	Shaft main	LA1500100	LA1500100	LA1501100	LA1502100
39	1	AISI329L	Dreven akse	Shaft aux	LA1600100	LA1600100	LA1601100	LA1602100
40	2	EN 6A	Feder, tandhjul	Gear key	L2180A101	L2180A101	L2180A101	L2180A101
43	1	EN 6A	Drivfeder	Drive key	L2181A100	L2181A100	L2181A100	L2181A100
44	2	St. 37-2	Lejring	Front spacer	LA1856100	LA1856100	LA1856100	LA1856100
45	2	-	Forreste leje	Bearing front	L2717100	L2717100	L2717100	L2717100
47	2	St. 37-2	Afstandscylinder, bageste leje	Spacer, rear bearing	LA1861100	LA1861100	LA1861100	LA1861100
48	2	-	Bagerste leje	Bearing rear	L2718100	L2718100	L2718100	L2718100
49	2	-	Spændskive, bagerste leje	Bearing rear tab washer	L2720025	L2720025	L2720025	L2720025
50	2	-	Møtrik, bagerste leje	Bearing rear nut	L2719025	L2719025	L2719025	L2719025
51	2	-	Lasering	Circlip	L2177100	L2177100	L2177100	L2177100
52	2	-	Afstandscylinder, tandhjul	Gear spacer	LA1850100	LA1850100	LA1850100	LA1850100
53	1	M.S.	Afstandskiver, tandhjul	Gear shims	L4000000	L4000000	L4000000	L4000000
54	1	-	Tandhjul(1 par)	Gear (1 pair)	LA2750100	LA2750100	LA2750100	LA2750100
55	2	-	Spændskive, gear	Gear tab washer	L2720020	L2720020	L2720020	L2720020
56	2	-	Møtrik, gear	Gear nut	L2719020	L2719020	L2719020	L2719020

7. Pumpe komplet / Pump complete

Std. DW 2

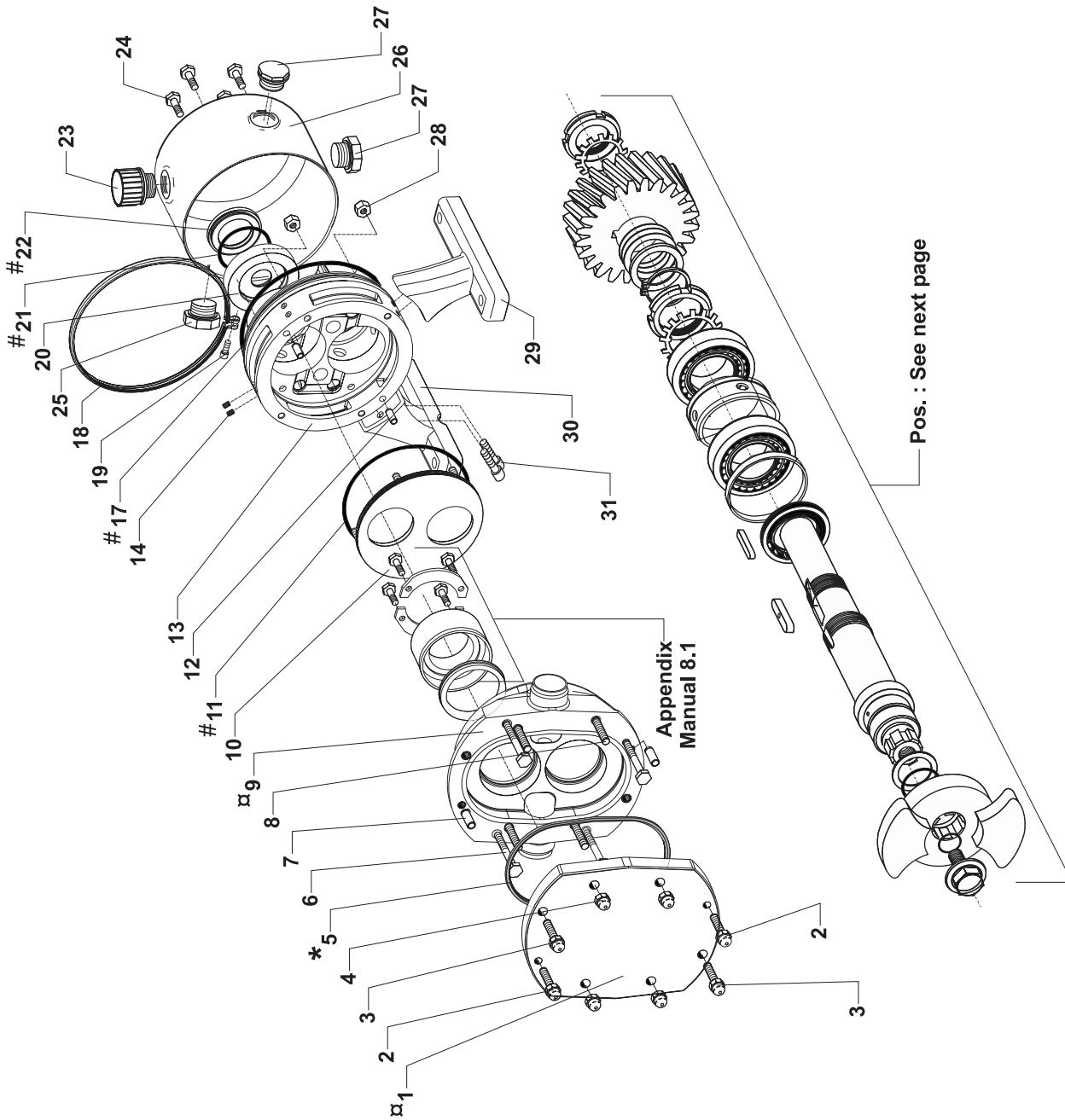

- * Produkt berørt paknings kit / Wet end seal kit
- # Gear boks paknings kit / Gear box seal kit

7. Pumpe komplet / Pump complete

Std. DW 2

NB! Nedenstående α varenumre, dækker ikke pumper solgt med 3.1 certifikat.
 For 3.1 reservedele, kontakt APV.
 α Part No. mentioned below, do not cover pumps sold with 3.1 certificate.
 For 3.1 spare parts, contact APV.

Pos	Stk/Qty	Material	Benævnelse	Description	Del nr. / Part No.			
					Piston	Lobe	Lobe	Lobe
					DW2/006/10	DW2/007/20	DW2/013/10	DW2/013/15_600
α 1	1	316L	Frontdæksel	Front cover	LA1110201	LA1110200	LA1110200	LA1110200
2	2	304S.S	Stor bolt, front plade	Big bolt, front cover	LA1000200	LA1000200	LA1000200	LA1000200
3	2	304S.S	Lille bolt, front plade	Small bolt, front cover	LA1001200	LA1001200	LA1001200	LA1001200
4	4	AISI 304	Møtrik, frontplade	Nut, front cover dome	L700243	L700243	L700243	L700243
6	4	304S.S	Skruer, rotorhus/ lejekonsol	Screw, rotor case to chassis	L773450	L773450	L773709	L773709
7	2	316S.S	Styrestift	Dowel	LA1160320	LA1002200	LA1002200	LA1002200
8	4	AISI 304	Støttebolt, frontplade	Stud, front cover	LA1002200	LA1002200	LA1002200	LA1002200
α 9	1	316L	Rotorhus	Rotor case	LA17992006	LA17992006	LA17992013	LA17992013
10	1	304S.S.	Olietætningsplade	Oil seat plate	LA1312200	LA1312200	LA1312200	LA1312200
12	2	316S.S	Styrestift, rotorhus/ lejekonsol	Dowel, rotor case to chassis	LA1160320	LA1160320	LA1160320	LA1160320
13	1	1.4305	Lejekonsol	Chassis	LA1302200	LA1302200	LA1302200	LA1302200
14	4	304S.S	Blindskruer	Plug	LA2000100	LA2000100	LA2000100	LA2000100
18	1	304S.S	Clampring	Clamp ring	LA1354200	LA1354200	LA1354200	LA1354200
19	1	304S.S	Skruer for clampring	Screw for clampring	L772962	L772962	L772962	L772962
20	1	Brass	Holder for læbetætning	Seal consol	LA1301200	LA1301200	LA1301200	LA1301200
23	1	Plastic	Oliepåfyldningsstuds	Oil filler plug	L2202000	L2202000	L2202000	L2202000
24	4	304S.S.	Skruer, holder for læbetætning	Screw, seal consol	L701517	L701517	L701517	L701517
25	1	Plastic	Olieskueglas	Oil level window	L2220000	L2220000	L2220000	L2220000
26	1	304S.S	Tandhjulskappe	Can	LA1364200	LA1364200	LA1364200	LA1364200
27	2	Plastic	Oliedrænprop	Oil drain plug	L2210A000	L2210A000	L2210A000	L2210A000
28	4	304S.S.	Klemåsemøtrik, olietætningsplade	Nut, oil seal plate	L773650	L773650	L773650	L773650
29 & 30	1	304S.S	Fødder (1 par)	Feet (1 pair)	LA1145200	LA1145200	LA1145200	LA1145200
31	4	304S.S	Skruer for fod	Screw for foot	L701057	L701057	L701057	L701057
* 5, 34 & 36	1	EPDM	Produktberørt paknings kit	Wet end seal kit	LA2380204	LA2380204	LA2380204	LA2380204
-	1	FPM (Viton)	Produktberørt paknings kit	Wet end seal kit	LA2380202	LA2380202	LA2380202	LA2380202
-	1	ISOLAST	Produktberørt paknings kit	Wet end seal kit	LA2380215	LA2380215	LA2380215	LA2380215
#11, 17, 21, 22 & 42	1	FPM (Viton)	Gear boks paknings kit	Gear box seal kit	LA2381202	LA2381202	LA2381202	LA2381202

7. Pumpe komplet / Pump complete

Std. DW 2

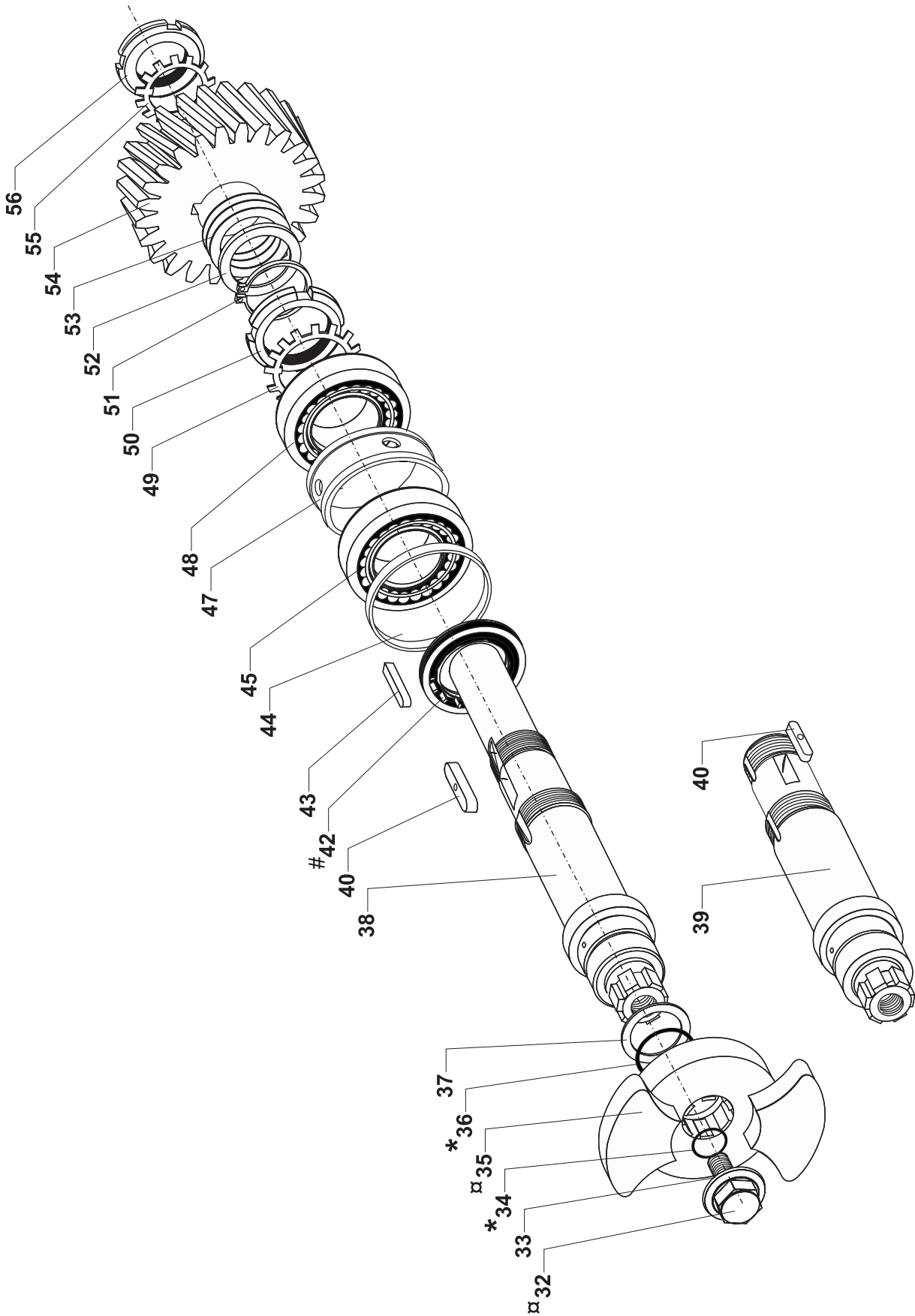

* Produkt berørt paknings kit / Wet end seal kit
 # Gear boks paknings kit / Gear box seal kit

7. Pumpe komplet / Pump complete

Std. DW 2

NBI! Nedenstående α varenumre, dækker ikke pumper solgt med 3.1 certifikat.
 For 3.1 reservedele, kontakt APV.
 α Part No. mentioned below, do not cover pumps sold with 3.1 certificate.
 For 3.1 spare parts, contact APV.

Pos	Stk/Qty	Material	Benævnelse	Description	Del nr. / Part No.			
					Piston DW2/006/10	Lobe DW2/007/20	Lobe DW2/013/10	Lobe DW2/013/15_600
α 32	2	329S.S	Rotor skrue incl friktionsring	Rotor Screw with washer	LA10502006	LA10502007	LA10502013	LA10502013
33	2	18/02	Friktionsring	Washer ring	LA2658200	LA2658200	LA2658200	LA2658200
α 35	2	316L	Rotor-høj virkningsgrad	Rotor-high efficiency	LA142006P2SH	LA14200721SH	LA14201321SH	LA1420131523SH
-	2	316L	Rotor-Multi-Duty	Rotor-Multi-Duty	LA142006P3SH	LA14200723SH	LA14201323SH	LA14201324WH
-	2	316L	Rotor-høj temperatur	Rotor-high temperature	LA142006P1SY	LA14200721SY	LA14201321SY	LA14201325WH
-	2	NGA	Rotor-høj virkningsgrad	Rotor-high efficiency	LA142006P4WH	LA14200724WH	LA14201324WH	LA14201324WH
-	2	NGA	Rotor-høj temperatur	Rotor-high temperature	LA14200724WH	LA14200724WH	LA14201324WH	LA14201324WH
-	2	NGA	Rotor-super tight	Rotor-super tight	LA142006P5WH	LA14200725WH	LA14201325WH	LA14201325WH
37	1	316S.S	Afstandskiver, rotor	Shims, rotor	L2657200	L2657200	L2657200	L2657200
38	1	AISI329L	Drivaksel	Shaft main	LA1500200	LA1500200	LA1501200	LA1501200
39	1	AISI329L	Dreven aksel	Shaft aux	LA1600200	LA1600200	LA1601200	LA1601200
40	2	EN 6A	Feder, tandhjul	Gear key	L2180A201	L2180A201	L2180A201	L2180A201
43	1	EN 6A	Drivfeder	Drive key	L2181A100	L2181A100	L2181A100	L2181A100
44	2	St. 37-2	Lejring	Front spacer	LA1856200	LA1856200	LA1856200	LA1856200
45	2	-	Forreste leje	Bearing front	L2717200	L2717200	L2717200	L2717200
47	2	St. 37-2	Afstandscylinder, bageste leje	Spacer, rear bearing	LA1861200	LA1861200	LA1861200	LA1861200
48	2	-	Bagerste leje	Bearing rear	L2718200	L2718200	L2718200	L2718200
49	2	-	Spændskive, bagerste leje	Bearing rear tab washer	L2720030	L2720030	L2720030	L2720030
50	2	-	Møtrik, bagerste leje	Bearing rear nut	L2719030	L2719030	L2719030	L2719030
51	2	-	Låsering	Circlip	L2177200	L2177200	L2177200	L2177200
52	2	-	Afstandscylinder, tandhjul	Gear spacer	LA1850200	LA1850200	LA1850200	LA1850200
53	1	M.S.	Afstandskiver, tandhjul	Gear shims	L4000100	L4000100	L4000100	L4000100
54	1	-	Tandhjul(1 par)	Gear (1 pair)	LA2750200	LA2750200	LA2750200	LA2750200
55	2	-	Spændskive, gear	Gear tab washer	L2720025	L2720025	L2720025	L2720025
56	2	-	Møtrik, gear	Gear nut	L2719025	L2719025	L2719025	L2719025

7. Pumpe komplet / Pump complete

Std. DW 3

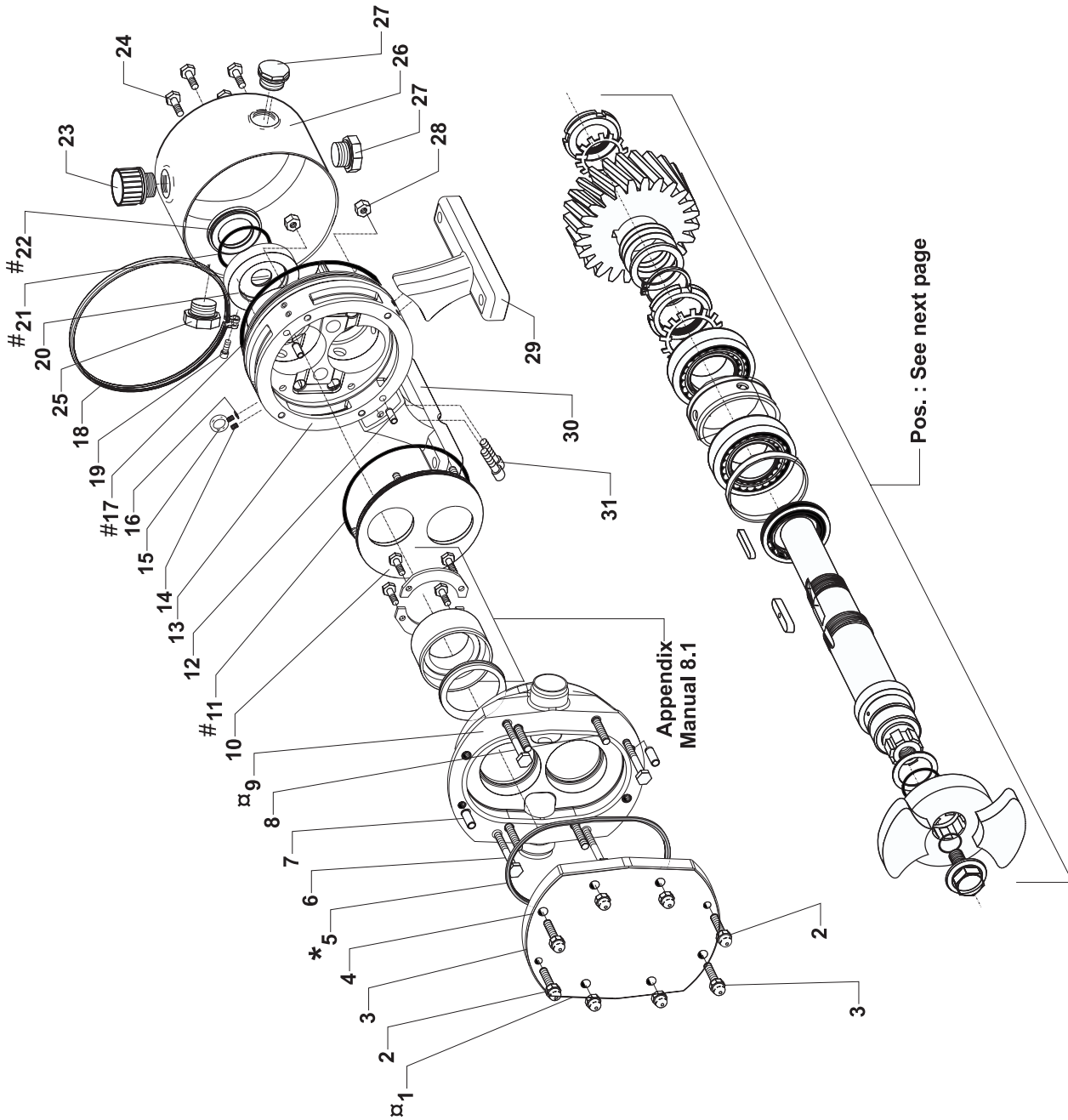

- * Produkt berørt paknings kit / Wet end seal kit
- # Gear boks paknings kit / Gear box seal kit

7. Pumpe komplet / Pump complete

Std. DW 3

NB! Nedenstående α varenumre, dækker ikke pumper solgt med 3.1 certifikat.
 For 3.1 reservedele, kontakt APV.
 α Part No. mentioned below, do not cover pumps sold with 3.1 certificate.
 For 3.1 spare parts, contact APV.

Pos	Stk/Qty	Material	Benævnelse	Description	Del nr. / Part No.				
					Piston DW3/014/10	Lobe DW3/017/20	Lobe DW3/030/10	Lobe DW3/030/15_600	Lobe DW3/050/5
α 1	1	316L	Frontdæksel	Front cover	LA1110301	LA1110300	LA1110300	LA1110300	LA1110300
2	2	304S.S	Stor bolt, front plade	Big bolt, front cover	LA1001300	LA1001300	LA1001300	LA1001300	LA1001300
3	2	304S.S	Lille bolt, front plade	Small bolt, front cover	LA1000300	LA1000300	LA1000300	LA1000300	LA1000300
4	4	AISI 304	Møtrik, frontplade	Nut, front cover dome	L700244	L700244	L700244	L700244	L700244
6	4	304S.S	Skrue, rotorhus/lejekonsol	Screw, rotor case to chassis	L772098	L772098	L772496	L772496	L773827
7	2	316S.S	Styrestift	Dowel	LA1160320	LA1160320	LA1160320	LA1160320	LA1160320
8	4	AISI 304	Støttebolt, frontplade	Stud, front cover	LA1002300	LA1002300	LA1002300	LA1002300	LA1002300
α 9	1	316L	Rotorhus	Rotor case	LA17993014	LA17993014	LA17993030	LA17993030	LA17993050
10	1	304S.S	Olietætningsplade	Oilseal plate	LA1312300	LA1312300	LA1312300	LA1312300	LA1312300
12	2	316S.S	Styrestift, rotorhus/lejekonsol	Dowel, rotor case to chassis	LA1160320	LA1160320	LA1160320	LA1160320	LA1160320
13	1	1. 4305	Lejekonsol	Chassis	LA1302300	LA1302300	LA1302300	LA1302300	LA1302300
14	2	304S.S	Blindskruer	Plug	LA2000100	LA2000100	LA2000100	LA2000100	LA2000100
15	2	AISI 304	Ringbolt	Lifting Eye bolt	L773815	L773815	L773815	L773815	L773815
16	2	Nylon	Skive	Washer	L773813	L773813	L773813	L773813	L773813
18	1	304S.S	Clampring	Clamp ring	LA1354300	LA1354300	LA1354300	LA1354300	LA1354300
19	1	304S.S	Skrue for clampring	Screw for clampring	L772962	L772962	L772962	L772962	L772962
20	1	Brass	Holder for læbetætning	Seal consol	LA1301300	LA1301300	LA1301300	LA1301300	LA1301300
23	1	Plastic	Oliefyldningsstuds	Oil filler plug	L2202000	L2202000	L2202000	L2202000	L2202000
24	4	304S.S.	Skrue, holder for læbetætning	Screw, seal consol	L701517	L701517	L701517	L701517	L701517
25	1	Plastic	Olieskueglas	Oil level window	L2220000	L2220000	L2220000	L2220000	L2220000
26	1	304S.S	Tandhjulskeppe	Can	LA1364300	LA1364300	LA1364300	LA1364300	LA1364300
27	2	Plastic	Oliedrænprop	Oil drain plug	L2210A000	L2210A000	L2210A000	L2210A000	L2210A000
28	4	304S.S	Klemfæsmøtrik, olietætningsplade	Nut, oil seal plate	L773650	L773650	L773650	L773650	L773650
29 & 30	1	304S.S	Fødder (1 par)	Feet (1 pair)	LA1145300	LA1145300	LA1145300	LA1145300	LA1145300
31	4	304S.S	Skrue for fod	Screw for foot	L701057	L701057	L701057	L701057	L701057
*5, 34 & 36	1	EPDM	Produktberørt paknings kit	Wet end seal kit	LA2380304	LA2380304	LA2380304	LA2380304	LA2380304
-	1	FPM (Viton)	Produktberørt paknings kit	Wet end seal kit	LA2380302	LA2380302	LA2380302	LA2380302	LA2380302
-	1	ISOLAST	Produktberørt paknings kit	Wet end seal kit	LA2380315	LA2380315	LA2380315	LA2380315	LA2380315
#11, 17, 21, 22 & 42	1	FPM (Viton)	Gear boks paknings kit	Gear box seal kit	LA2381302	LA2381302	LA2381302	LA2381302	LA2381302

7. Pumpe komplet / Pump complete

Std. DW 3

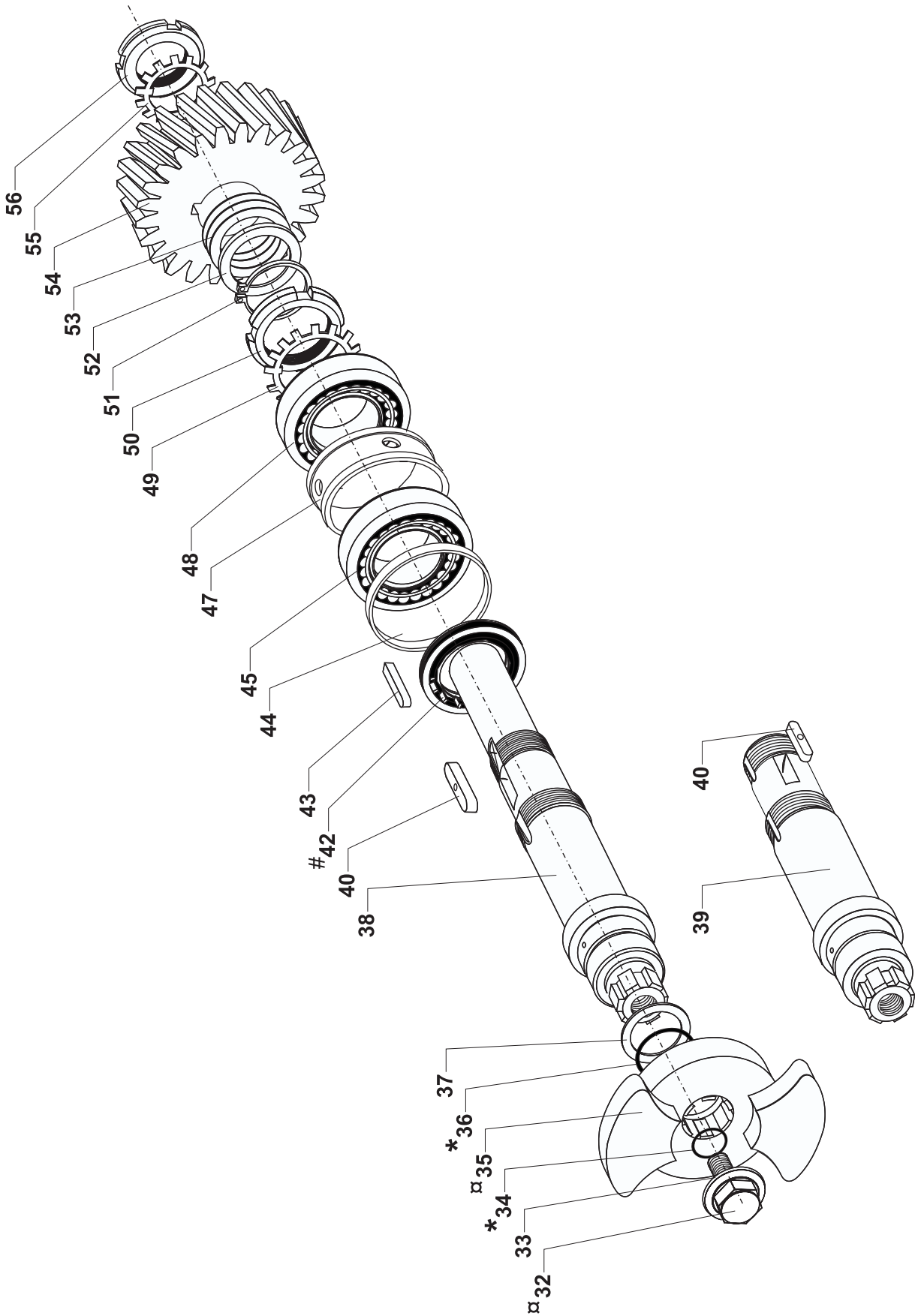

* Produkt berørt paknings kit / Wet end seal kit
 # Gear boks paknings kit / Gear box seal kit

7. Pumpe komplet / Pump complete

Std. DW 3

NBI! Nedenstående α varenumre, dækker ikke pumper solgt med 3.1 certifikat.
 For 3.1 reservedele, kontakt APV.
 α Part No. mentioned below, do not cover pumps sold with 3.1 certificate.
 For 3.1 spare parts, contact APV.

Pos	Stk/Qty	Material	Benævnelse	Description	Del nr. / Part No.					
					Piston	Lobe	Lobe	Lobe	Lobe	
					DW3/014/10	DW3/017/20	DW3/030/10	DW3/030/15_600	DW3/050/5	
α 32	2	329S.S	Rotor skrue incl friktionsring	Rotor Screw with washer	LA10503014	LA10503016	LA10503030	LA10503030	LA10503030	LA10503050
33	2	18/02	Friktionsring	Washer ring	LA2658300	LA2658300	LA2658300	LA2658300	LA2658300	LA2658301
α 35	2	3-16L	Rotor-høj virkningsgrad	Rotor-high efficiency	LA143014P2SH	LA14301621SH	LA14303021SH	LA14303021SH	LA14305021SH	LA14305021SH
-	2	3-16L	Rotor-Multi-Duty	Rotor-Multi-Duty	LA143014P3SH	LA14301623SH	LA14303023SH	LA14303023SH	LA14305023SH	LA14305023SH
-	2	3-16L	Rotor-høj temperatur	Rotor-high temperature	LA143014P1SY	LA14301621SY	LA14303021SY	LA14303021SY	LA14305021SY	LA14305021SY
-	2	NGA	Rotor-høj virkningsgrad	Rotor-high efficiency	LA143014P4WH	LA14301624WH	LA14303024WH	LA14303024WH	LA14305024WH	LA14305024WH
-	2	NGA	Rotor-høj temperatur	Rotor-high temperature	LA143014P4WY	LA14301624WY	LA14303024WY	LA14303024WY	LA14305024WY	LA14305024WY
-	2	NGA	Rotor-super tight	Rotor-super tight	LA143014P5WH	LA14301625WH	LA14303025WH	LA14303025WH	LA14305025WH	LA14305025WH
37	1	316S.S	Afstandsskiver, rotor	Shims, rotor	L2657300	L2657300	L2657300	L2657300	L2657300	L2657300
38	1	AlSi329L	Drivaksel	Shaft main	LA1500300	LA1500300	LA1501300	LA1501300	LA1501300	LA1501300
39	1	AlSi329L	Dreven aksel	Shaft aux	LA1600300	LA1600300	LA1601300	LA1601300	LA1601300	LA1601300
40	2	EN 6A	Feder, tandhjul	Gear key	L2180A301	L2180A301	L2180A301	L2180A301	L2180A301	L2180A301
43	1	EN 6A	Drivfeder	Drive key	L2181A300	L2181A300	L2181A300	L2181A300	L2181A300	L2181A300
44	2	St.37-2	Lejering	Front spacer	LA1856301	LA1856301	LA1856301	LA1856301	LA1856301	LA1856301
45	2	-	Forreste leje	Bearing front	L2717301	L2717301	L2717301	L2717301	L2717301	L2717301
47	2	St.37-2	Afstandscylinder, bageste leje	Spacer rear bearing	LA1861300	LA1861300	LA1861300	LA1861300	LA1861300	LA1861300
48	2	-	Bagerste leje	Bearing rear	L2718300	L2718300	L2718300	L2718300	L2718300	L2718300
49	2	-	Spændskive, bagerste leje	Bearing rear tab washer	L2720035	L2720035	L2720035	L2720035	L2720035	L2720035
50	2	-	Møtrik, bagerste leje	Bearing rear nut	L2719035	L2719035	L2719035	L2719035	L2719035	L2719035
51	2	-	Låsering	Circlip	L2177300	L2177300	L2177300	L2177300	L2177300	L2177300
52	2	-	Afstandscylinder, tandhjul	Gear spacer	LA1850300	LA1850300	LA1850300	LA1850300	LA1850300	LA1850300
53	1	M.S.	Afstandsskiver, tandhjul	Gear shims	L4000A300	L4000A300	L4000A300	L4000A300	L4000A300	L4000A300
54	1	-	Tandhjul (1 Par)	Gear (1 pair)	LA2750300	LA2750300	LA2750300	LA2750300	LA2750300	LA2750300
55	2	-	Spændskive, gear	Gear tab washer	L2720030	L2720030	L2720030	L2720030	L2720030	L2720030
56	2	-	Møtrik, gear	Gear nut	L2719030	L2719030	L2719030	L2719030	L2719030	L2719030

7. Pumpe komplet / Pump complete

Std. DW 4

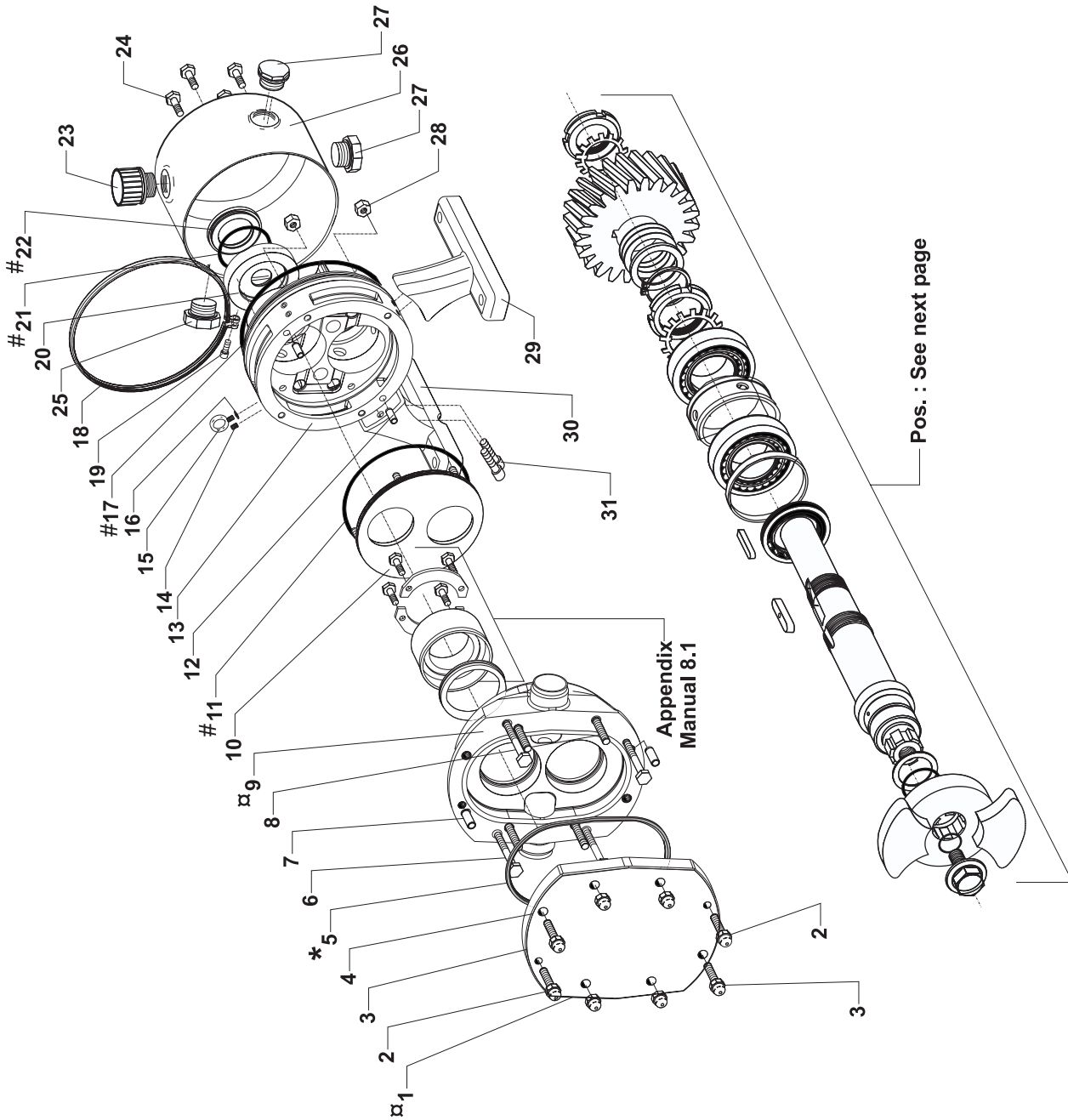

- * Produkt berørt paknings kit / Wet end seal kit
- # Gear boks paknings kit / Gear box seal kit

7. Pumpe komplet / Pump complete

Std. DW 4

NBI! Nedenstående α varenumre, dækker ikke pumper solgt med 3.1 certifikat.
 For 3.1 reservedele, kontakt APV.
 α Part No. mentioned below, do not cover pumps sold with 3.1 certificate.
 For 3.1 spare parts, contact APV.

Pos	Stk / Qty	Material	Benævnelse	Description	Del nr. / Part No.						
					Piston	Lobe	Lobe	Lobe	Lobe	Lobe	
α 1	1	316L	Frontdæksel	Front cover	LA1110401	LA1110400	LA1110400	LA1110400	LA1110400	LA1110400	LA1110400
2	2	304S.S	Stor bolt, front plade	Big bolt, front cover	LA1000400	LA1000400	LA1000400	LA1000400	LA1000400	LA1000400	LA1000400
3	2	304S.S	Lille bolt, front plade	Small bolt, front cover	LA1001400	LA1001400	LA1001400	LA1001400	LA1001400	LA1001400	LA1001400
4	4	304S.S	Møtrik, frontplade	Nut, front cover dome	L700244	L700244	L700244	L700244	L700244	L700244	L700244
6	4	304S.S	Skrue, rotorhus/lejekonsol	Screw, rotor case to chassis	L771606	L771606	L771606	L771606	L771606	L771606	L771606
7	2	316S.S	Styrestift	Dowel	LA1160320	LA1160320	LA1160320	LA1160320	LA1160320	LA1160320	LA1160320
8	4	304S.S	Støttebolt, frontplade	Stud, front cover	LA1002400	LA1002400	LA1002400	LA1002400	LA1002400	LA1002400	LA1002400
α 9	1	316L	Rotorhus	Rotor case	LA17994033	LA17994033	LA17994033	LA17994033	LA17994033	LA17994033	LA17994033
10	1	304S.S	Olietætningsplade	Oilseal plate	LA1312400	LA1312400	LA1312400	LA1312400	LA1312400	LA1312400	LA1312400
12	2	316S.S	Styrestift, rotorhus/lejekonsol	Dowel, rotor case to chassis	LA1160420	LA1160420	LA1160420	LA1160420	LA1160420	LA1160420	LA1160420
13	1	1. 4305	Lejekonsol	Chassis	LA1302400	LA1302400	LA1302400	LA1302400	LA1302400	LA1302400	LA1302400
14	2	304S.S	Blindskruer	Plug	LA2000400	LA2000400	LA2000400	LA2000400	LA2000400	LA2000400	LA2000400
15	2	304S.S	Ringbolt	Lifting Eye bolt	LA2101410	LA2101410	LA2101410	LA2101410	LA2101410	LA2101410	LA2101410
16	2	Nylon	Skive	Washer	L773655	L773655	L773655	L773655	L773655	L773655	L773655
18	1	304S.S	Clampring	Clamp ring	LA1354400	LA1354400	LA1354400	LA1354400	LA1354400	LA1354400	LA1354400
19	1	304S.S	Skrue for clampring	Screw for clampring	L772962	L772962	L772962	L772962	L772962	L772962	L772962
20	1	Brass	Holder for læbetætning	Seal consol	LA1301400	LA1301400	LA1301400	LA1301400	LA1301400	LA1301400	LA1301400
23	1	Plastic	Oliepåfyldningsstuds	Oil filler plug	L2202000	L2202000	L2202000	L2202000	L2202000	L2202000	L2202000
24	4	304S.S.	Skrue, holder for læbetætning	Screw, seal consol	L773454	L773454	L773454	L773454	L773454	L773454	L773454
25	1	Plastic	Olieskueglas	Oil level window	L2220000	L2220000	L2220000	L2220000	L2220000	L2220000	L2220000
26	1	304S.S	Tandhjulskappe	Can	LA1364400	LA1364400	LA1364400	LA1364400	LA1364400	LA1364400	LA1364400
27	2	Plastic	Oliedråenprop	Oil drain plug	L2210A000	L2210A000	L2210A000	L2210A000	L2210A000	L2210A000	L2210A000
28	4	304S.S	Klemåsemøtrik, olietætningsplade	Nut, oil seal plate	L773651	L773651	L773651	L773651	L773651	L773651	L773651
29 & 30	1	304S.S	Fødder (1 par)	Feet (1 pair)	LA1145400	LA1145400	LA1145400	LA1145400	LA1145400	LA1145400	LA1145400
31	4	304S.S	Skrue for fod	Screw for foot	L773656	L773656	L773656	L773656	L773656	L773656	L773656
*5, 34 & 36	1	EPDM	Produktberørt paknings kit	Wet end seal kit	LA2380404	LA2380404	LA2380404	LA2380404	LA2380404	LA2380404	LA2380404
-	1	FPM (Viton)	Produktberørt paknings kit	Wet end seal kit	LA2380402	LA2380402	LA2380402	LA2380402	LA2380402	LA2380402	LA2380402
-	1	ISOLAST	Produktberørt paknings kit	Wet end seal kit	LA2380415	LA2380415	LA2380415	LA2380415	LA2380415	LA2380415	LA2380415
#11, 17, 21, 22 & 42	1	FPM (Viton)	Gear boks paknings kit	Gear box seal kit	LA2381402	LA2381402	LA2381402	LA2381402	LA2381402	LA2381402	LA2381402

7. Pumpe komplet / Pump complete

Std. DW 4

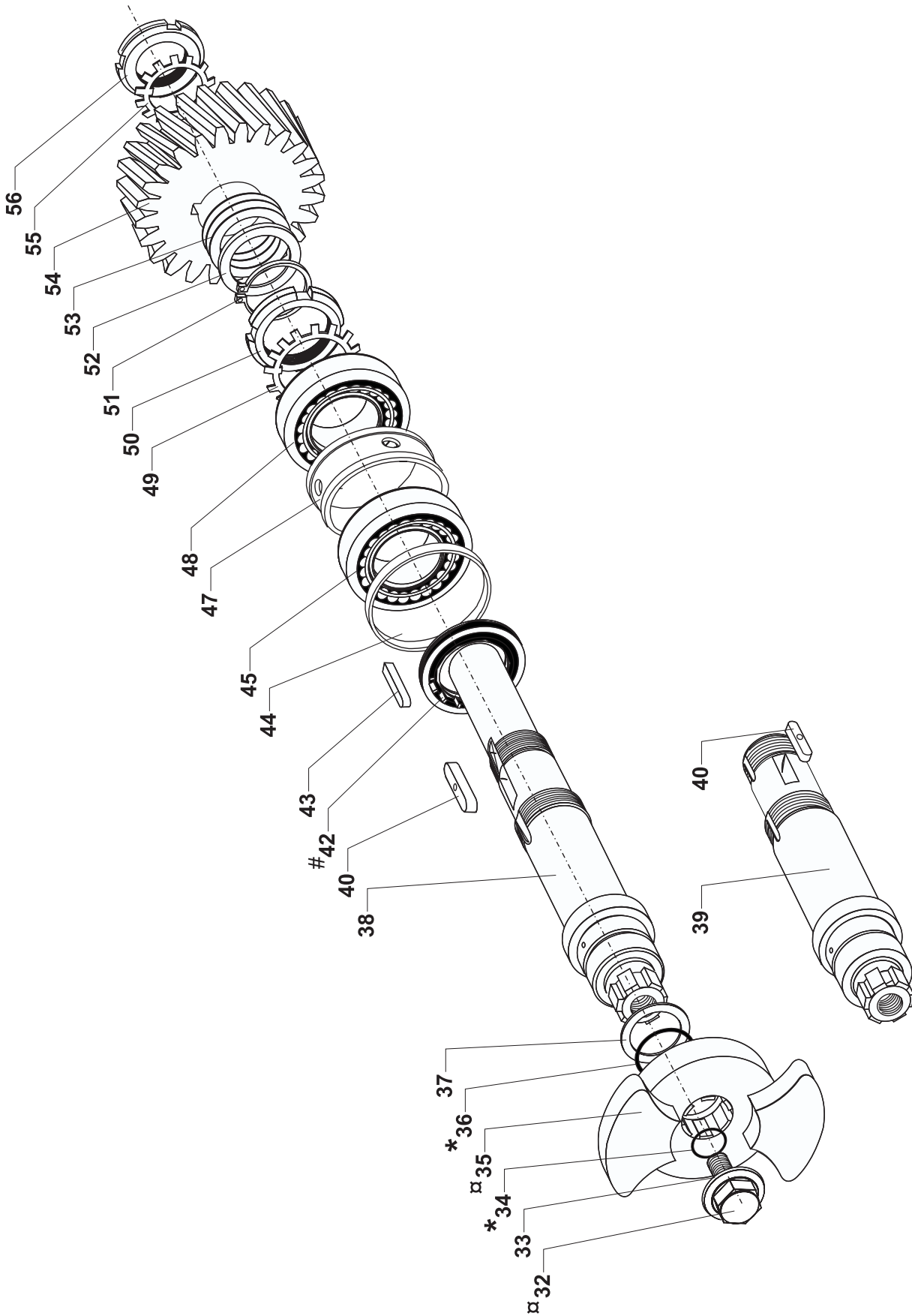

* Produkt berørt paknings kit / Wet end seal kit
 # Gear boks paknings kit / Gear box seal kit

7. Pumpe komplet / Pump complete

Std. DW 4

NBI! Nedenstående α varenumre, dækker ikke pumper solgt med 3.1 certifikat.
 For 3.1 reservedele, kontakt APV.
 α Part No. mentioned below, do not cover pumps sold with 3.1 certificate.
 For 3.1 spare parts, contact APV.

Pos	Stk / Qty	Material	Benævnelse	Description	Del nr. / Part No.					
					Piston	Lobe	Lobe	Lobe	Lobe	Lobe
					DW4/033/10	DW4/039/20	DW4/073/10	DW4/073/15_600	DW4/125/5	DW4/125/7_600
α 32	2	329S.S	Rotor skrue incl friktionsring	Rotor Screw with washer	LA10504033	LA10504039	LA10504039	LA10504125	LA10504125	LA10504125
33	2	18/02	Friktionsring	Washer ring	LA2658400	LA2658400	LA2658400	LA2658401	LA2658401	LA2658401
α 35	2	316L	Rotor-høj virkningsgrad	Rotor-high efficiency	LA144033P2SH	LA14403921SH	LA14407321SH	LA14412521SH	LA14412521SH	LA14412521SH
-	2	316L	Rotor-Multi-Duty	Rotor-Multi-Duty	LA144033P3SH	LA14403923SH	LA14407323SH	LA14412523SH	LA14412523SH	LA14412523SH
-	2	316L	Rotor-høj temperatur	Rotor-high temperature	LA144033P1SY	LA14403921SY	LA14407321SY	LA14412521SY	LA14412521SY	LA14412521SY
-	2	NGA	Rotor-høj virkningsgrad	Rotor-high efficiency	LA144033P4WH	LA14403924WH	LA14407324WH	LA14412524WH	LA14412524WH	LA14412524WH
-	2	NGA	Rotor-høj temperatur	Rotor-high temperature	LA144033P4WY	LA14403924WY	LA14407324WY	LA14412524WY	LA14412524WY	LA14412524WY
-	2	NGA	Rotor-super tight	Rotor-super tight	LA144033P5WH	LA14403925WH	LA14407325WH	LA14412525WH	LA14412525WH	LA14412525WH
37	1	316S.S	Afstandskiver, rotor	Shims, rotor	L2657400	L2657400	L2657400	L2657400	L2657400	L2657400
38	1	AIS1329L	Drivaksel	Shaft main	LA1500400	LA1500400	LA1501400	LA1501400	LA1501400	LA1501400
39	1	AIS1329L	Dreven aksel	Shaft aux	LA1600400	LA1600400	LA1601400	LA1601400	LA1601400	LA1601400
40	2	EN 6A	Feder, tandhjul	Gear key	L2180A401	L2180A401	L2180A401	L2180A401	L2180A401	L2180A401
43	1	EN 6A	Drivfeder	Drive key	L2181A400	L2181A400	L2181A400	L2181A400	L2181A400	L2181A400
44	2	St.37-2	Lejring	Front spacer	LA1856400	LA1856400	LA1856400	LA1856400	LA1856400	LA1856400
45	2	-	Forreste leje	Bearing front	L2717400	L2717400	L2717400	L2717400	L2717400	L2717400
47	2	St.37-2	Afstandscylinder, bageste leje	Spacer rear bearing	LA1861400	LA1861400	LA1861400	LA1861400	LA1861400	LA1861400
48	2	-	Bagerste leje	Bearing rear	L2718400	L2718400	L2718400	L2718400	L2718400	L2718400
49	2	-	Bagerste leje	Bearing rear tab washer	L2720045	L2720045	L2720045	L2720045	L2720045	L2720045
50	2	-	Spændskive, bagerste leje	Bearing rear nut	L2719045	L2719045	L2719045	L2719045	L2719045	L2719045
51	2	-	Møtrik, bagerste leje	Circlip	L2177400	L2177400	L2177400	L2177400	L2177400	L2177400
52	2	-	Låsering	Gear spacer	LA1850400	LA1850400	LA1850400	LA1850400	LA1850400	LA1850400
53	1	M.S.	Afstandscylinder, tandhjul	Gear shims	L4000200	L4000200	L4000200	L4000200	L4000200	L4000200
54	1	-	Afstandskiver, tandhjul	Gear (1 pair)	LA2750400	LA2750400	LA2750400	LA2750400	LA2750400	LA2750400
55	2	-	Tandhjul (1 Par)	Gear tab washer	L2720040	L2720040	L2720040	L2720040	L2720040	L2720040
56	2	-	Spændskive, gear	Gear nut	L2719040	L2719040	L2719040	L2719040	L2719040	L2719040
			Møtrik, gear							

7. Pumpe komplet / Pump complete

Std. DW 5

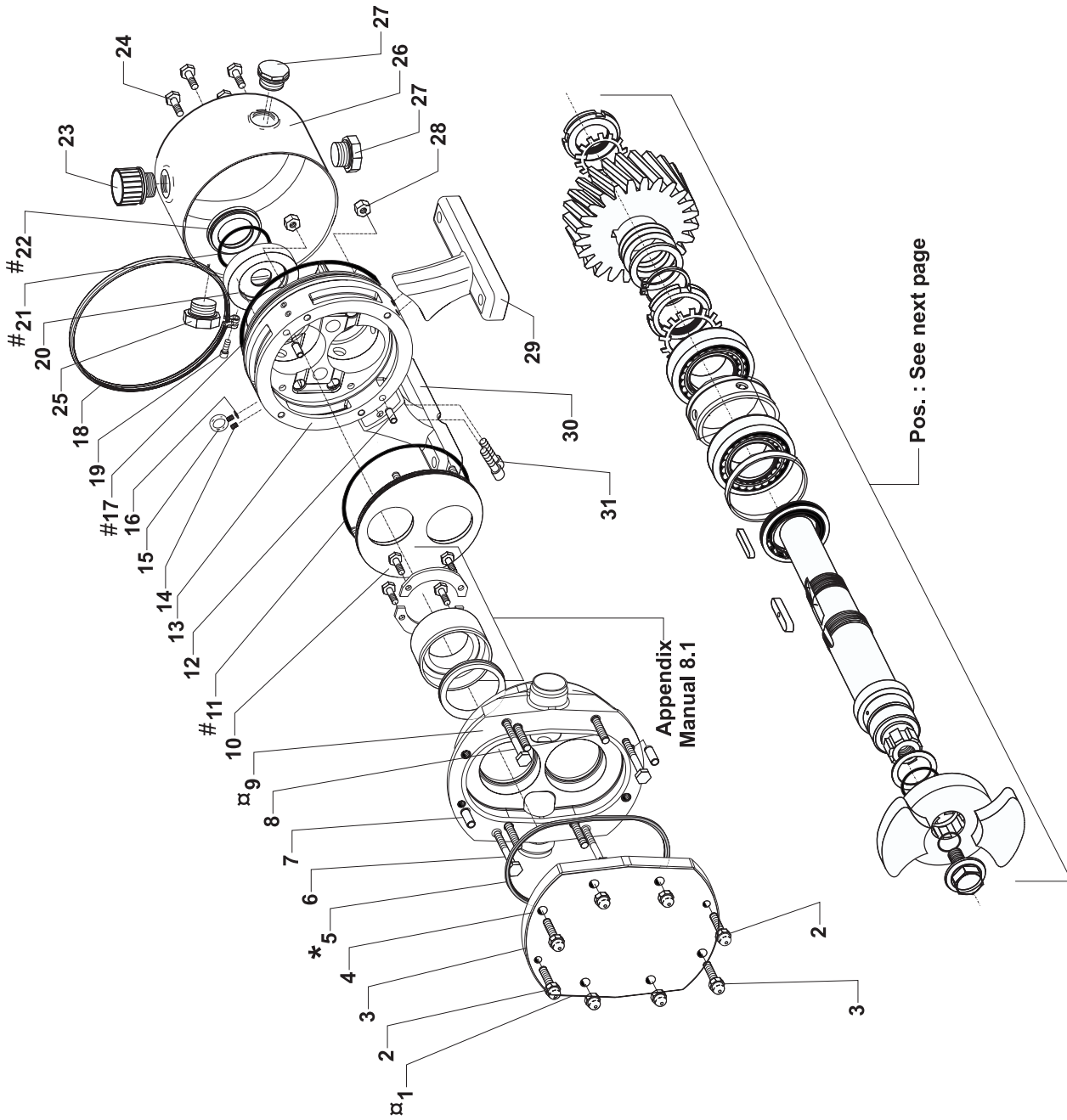

- * Produkt berørt paknings kit / Wet end seal kit
- # Gear boks paknings kit / Gear box seal kit

7. Pumpe komplet / Pump complete

Std. DW 5

NB! Nedenstående α varenumre, dækker ikke pumper solgt med 3.1 certifikat.
 For 3.1 reservedele, kontakt APV.
 α Part No. mentioned below, do not cover pumps sold with 3.1 certificate.
 For 3.1 spare parts, contact APV.

Pos	Stk/Qty	Material	Benævneelse	Description	Del nr. / Part No.			
					Piston	Lobe	Lobe	Lobe
					DW5/080/12.5	DW5/093/25	DW5/142/15	DW5/256/7
α 1	1	316L	Frontdæksel	Front cover	LA1110501	LA1110500	LA1110500	LA1110500
2	2	304S.S	Stor bolt, front plade	Big bolt, front cover	LA1000500	LA1000500	LA1000500	LA1000500
3	2	304S.S	Lille bolt, front plade	Small bolt, front cover	LA1001500	LA1001500	LA1001500	LA1001500
4	4	AISI 304	Møtrik, frontplade	Nut, front cover dome	L773456	L773456	L773456	L773456
6	4	304S.S	Skrue, rotorhus/lejekonsol	Screw, rotor case to chassis	L773500	L773500	L702060	L773482
7	2	316S.S	Styrestift	Dowel	LA1160520			
8	4	AISI 304	Støttebolt, frontplade	Stud, front cover	LA1002500	LA1002500	LA1002500	LA1002500
α 9	1	316L	Rotorhus	Rotor case	LA17995080	LA17995080	LA17995142	LA17995256
10	1	304S.S	Oljetætningsplade	Oilseal plate	LA1312500	LA1312500	LA1312500	LA1312500
12	2	316S.S	Styrestift, rotorhus/lejekonsol	Dowel, rotor case to chassis	LA1160520	LA1160520	LA1160520	LA1160520
13	1	1. 4305	Lejekonsol	Chassis	LA1302500	LA1302500	LA1302500	LA1302500
14	2	304S.S	Blindskruer	Plug	LA2000500	LA2000500	LA2000500	LA2000500
15	2	AISI304	Ringbolt	Lifting Eye bolt	LA2101512	LA2101512	LA2101512	LA2101512
16	2	Nylon	Skive	Washer	L773654	L773654	L773654	L773654
18	1	304S.S	Clampring	Clamp ring	LA1354500	LA1354500	LA1354500	LA1354500
19	1	304S.S	Skrue for clampring	Screw for clampring	L772962	L772962	L772962	L772962
20	1	Brass	Holder for læbetætning	Seal consol	LA1301501	LA1301501	LA1301501	LA1301501
23	1	Plastic	Oliefyldningsstuds	Oil filler plug	L2202000	L2202000	L2202000	L2202000
24	4	304S.S.	Skrue, holder for læbetætning	Screw, seal consol	L773455	L773455	L773455	L773455
25	1	Plastic	Olieskueglas	Oil level window	L2220000	L2220000	L2220000	L2220000
26	1	304S.S	Tandhjulskappe	Can	LA1364500	LA1364500	LA1364500	LA1364500
27	2	Plastic	Oliedrænprop	Oil drain plug	L2210A000	L2210A000	L2210A000	L2210A000
28	4	304S.S	Klemåsemøtrik, oljetætningsplade	Nut, oil seal plate	L773652	L773652	L773652	L773652
29 & 30	1	304S.S	Fødder (1 par)	Feet (1 pair)	LA1145500	LA1145500	LA1145500	LA1145500
31	4	304S.S	Skrue for fod	Screw for foot	L773657	L773657	L773657	L773657
*5, 34 & 36	1	EPDM	Produktberørt paknings kit	Wet end seal kit	LA2380504	LA2380504	LA2380504	LA2380504
-	1	FPM (Viton)	Produktberørt paknings kit	Wet end seal kit	LA2380502	LA2380502	LA2380502	LA2380502
-	1	ISOLAST	Produktberørt paknings kit	Wet end seal kit	LA2380515	LA2380515	LA2380515	LA2380515
#11, 17, 21, 22 & 42	1	FPM (Viton)	Gear boks paknings kit:	Gear box seal kit:	LA2381502	LA2381502	LA2381502	LA2381502
-	1	-	Pumpe serie nr. \geq 10.000.733	Pump Serial nr. \geq 10.000.733	LA2381502	LA2381502	LA2381502	LA2381502
-	1	-	Pumpe serie nr. \leq 10.002.262	Pump Serial nr. \leq 10.002.262	LA2381512	LA2381512	LA2381512	LA2381512
-	1	-	Pumpe serie nr. \geq 10.002.263	Pump Serial nr. \geq 10.002.263	LA2381522	LA2381522	LA2381522	LA2381522

7. Pumpe komplet / Pump complete

Std. DW 5

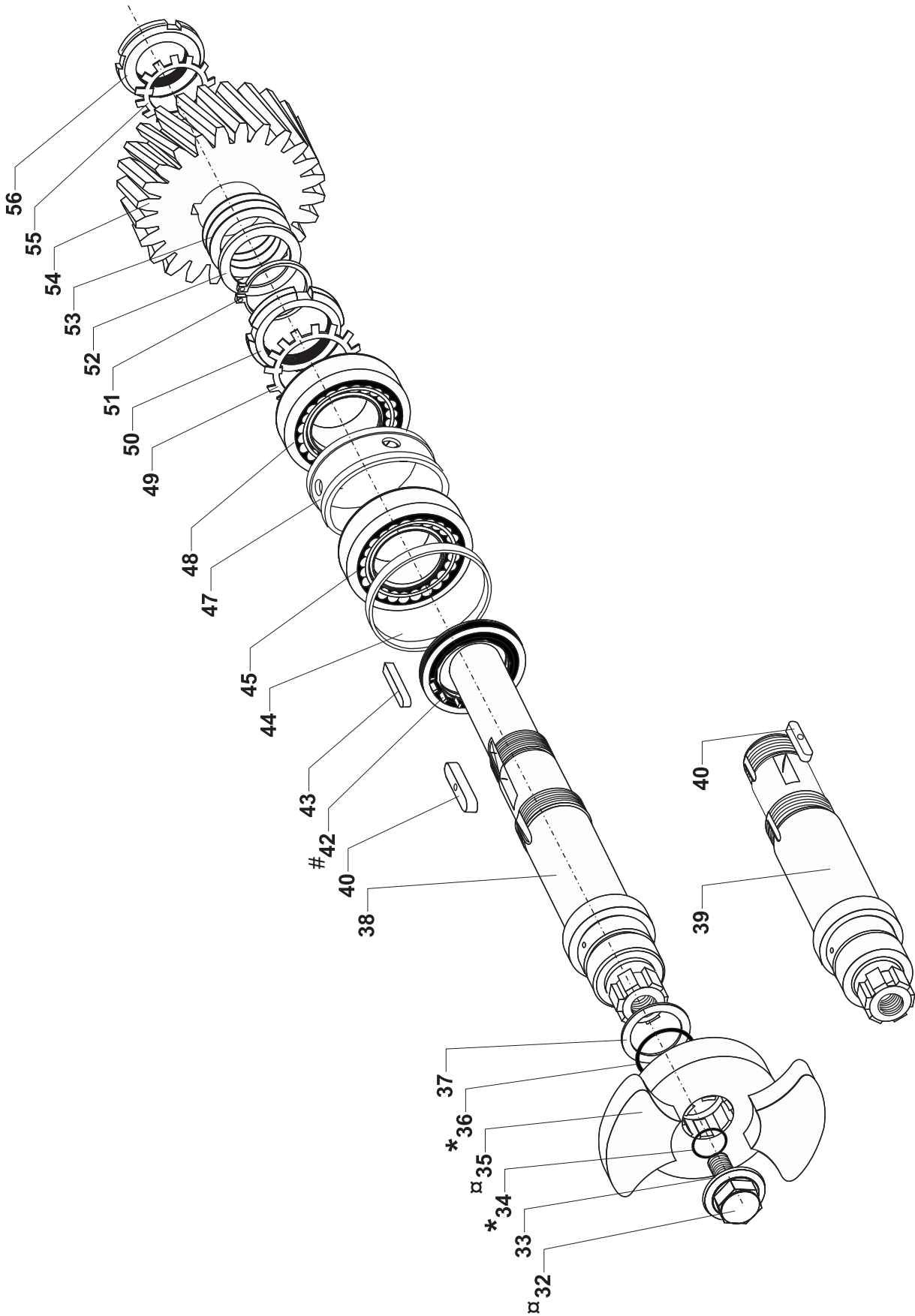

* Produkt berørt paknings kit / Wet end seal kit
 # Gear boks paknings kit / Gear box seal kit

7. Pumpe komplet / Pump complete

Std. DW 5

NBI! Nedenstående \approx varenumre, dækker ikke pumper solgt med 3.1 certifikat.
 For 3.1 reservedele, kontakt APV.
 \approx Part No. mentioned below, do not cover pumps sold with 3.1 certificate.
 For 3.1 spare parts, contact APV.

Pos	Stk/Qty	Material	Benævnelse	Description	Del nr. / Part No.			
					Piston	Lobe	Lobe	Lobe
					DW5/080/12.5	DW5/093/25	DW5/142/15	DW5/256/7
32	2	329S.S	Rotor skrue incl friktionsring	Rotor Screw with washer	LA10505080	LA10505093	LA10505142	LA10505256
33	2	18/02	Friktionsring	Washer ring	LA2658500	LA2658500	LA2658500	LA2658500
35	2	316L	Rotor-høj virkningsgrad	Rotor-high efficiency	LA145080P2SH	LA14509321SH	LA14514221SH	LA14525621SH
-	2	316L	Rotor-Multi-Duty	Rotor-Multi-Duty	LA145080P3SH	LA14509323SH	LA14514223SH	LA14525623SH
-	2	316L	Rotor-høj temperatur	Rotor-high temperature	LA145080P1SY	LA14509321SY	LA14514221SY	LA14525621SY
-	2	NGA	Rotor-høj virkningsgrad	Rotor-high efficiency	LA145080P4WH	LA14509324WH	LA14514224WH	LA14525624WH
-	2	NGA	Rotor høj temperatur	Rotor-high temperature	LA145080P4WY	LA14509324WY	LA14514224WY	LA14525624WY
-	2	NGA	Rotor-super tight	Rotor-super tight	LA145080P5WH	LA14509325WH	LA14514225WH	LA14525625WH
37	1	316S.S	Afstandsskiver, rotor	Shims, rotor	L2657500	L2657500	L2657500	L2657500
38	1	AISI329L	Drivaksel	Shaft main	LA1500500	LA1500500	LA1501500	LA1501500
39	1	AISI329L	Dreven aksel	Shaft aux	LA1600500	LA1600500	LA1601500	LA1601500
40	2	EN 6A	Feder, tandhjul	Gear key	L2180A500	L2180A500	L2180A500	L2180A500
43	1	EN 6A	Drivfeder	Drive key	L2181A500	L2181A500	L2181A500	L2181A500
44	2	St.37-2	Lejring	Front spacer	LA1856500	LA1856500	LA1856500	LA1856500
45	4	-	Forreste leje	Bearing front	L2717500	L2717500	L2717500	L2717500
46	2	M.S.	Afstandscylinder,forreste leje	Spacer,front bearing	LA1860500	LA1860500	LA1860500	LA1860500
47	2	M.S.	Afstandscylinder,bagerste leje	Spacer,rear bearing	LA1861500	LA1861500	LA1861500	LA1861500
48	2	-	Bagerste leje	Bearing rear	L2718500	L2718500	L2718500	L2718500
49	2	-	Spændskive, bagerste leje	Bearing rear tab washer	L2720050	L2720050	L2720050	L2720050
50	2	-	Møtrik, bagerste leje	Bearing rear nut	L2719050	L2719050	L2719050	L2719050
51	2	-	Låsering	Circlip	L2177500	L2177500	L2177500	L2177500
52	2	-	Afstandscylinder, tandhjul	Gear spacer	LA1850500	LA1850500	LA1850500	LA1850500
53	1	M.S.	Afstandsskiver, tandhjul	Gear shims	L4000A500	L4000A500	L4000A500	L4000A500
54	1	-	Tandhjul (1 par)	Gear (1 pair)	LA2750500	LA2750500	LA2750500	LA2750500
55	2	-	Spændskive, gear	Gear tab washer	L2720045	L2720045	L2720045	L2720045
56	2	-	Møtrik, gear	Gear nut	L2719045	L2719045	L2719045	L2719045

7. Pumpe komplet / Pump complete

Std. DW 6

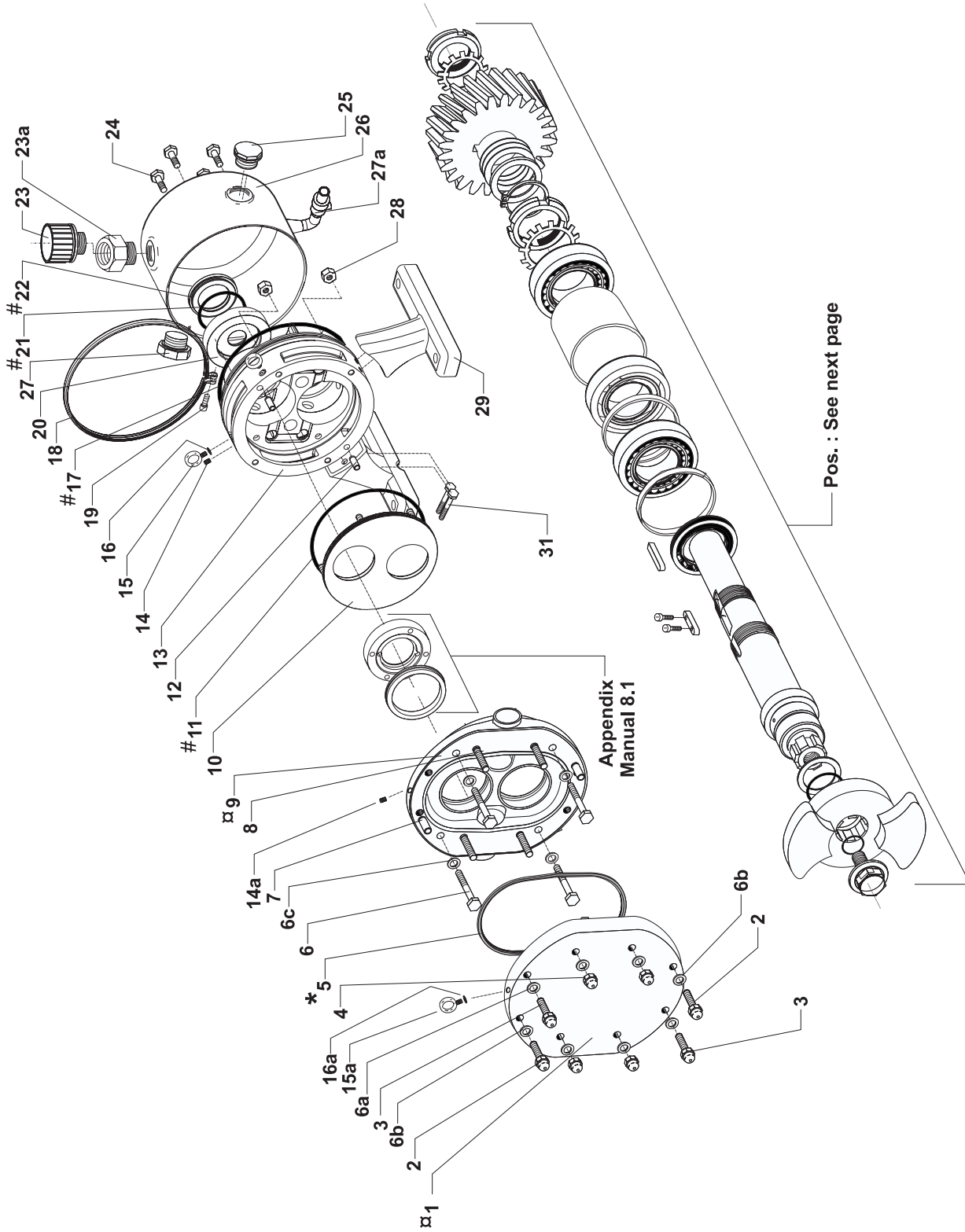

* Produkt berørt paknings kit / Wet end seal kit
 # Gear boks paknings kit / Gear box seal kit

7. Pumpe komplet / Pump complete

Std. DW 6

NB! Nedenstående α varenumre, dækker ikke pumper solgt med 3.1 certifikat.
 For 3.1 reservedele, kontakt APV.
 α Part No. mentioned below, do not cover pumps sold with 3.1 certificate.
 For 3.1 spare parts, contact APV.

Pos	Stk/Qty	Material	Benævnelse	Description	Del nr. / Part No.			
					Piston DW6/172/12.5	Lobe DW6/198/30	Lobe DW6/308/15	Lobe DW6/519/7
α 1	1	316L	Frontdæksel	Front cover	LA1100601	LA1100600	LA1100600	LA1100600
2	2	304S.S	Stor bolt, front plade	Big bolt, front cover	LA1000600	LA1000600	LA1000600	LA1000600
3	2	304S.S	Lille bolt, front plade	Small bolt, front cover	LA1001600	LA1001600	LA1001600	LA1001600
4	4	AISI 304	Møtrik, frontplade	Nut, front cover dome	L773719	L773719	L773719	L773719
6	4	304S.S	Skruer, rotorhus/lejekonsole	Screw, rotor case to chassis	L773715	L773715	L773705	L773716
6a	6	304S.S	Skive	Washer	L701254	L701254	L701254	L701254
6b	2	304S.S	Skive	Washer	LA2176002	LA2176002	LA2176002	LA2176002
6c	4	304S.S	Skive	Washer	L773488	L773488	L773488	L773488
7	2	316S.S	Styrestift	Dowel	L1162740	L1162740	L1162740	L1162740
8	4	AISI 304	Støttebolt, frontplade	Stud, front cover	LA1003601	LA1003601	LA1003601	LA1003601
α 9	1	316L	Rotorhus	Rotor case	LA17086172	LA17086198	LA17086308	LA17086519
10	1	304S.S	Olietætningsplade	Oilseal plate	LA1312600	LA1312600	LA1312600	LA1312600
12	2	316S.S	Styrestift, rotorhus/lejekonsole	Dowel, rotor case to chassis	LA1160860	LA1160860	LA1160860	LA1160860
13	1	AISI 304	Lejekonsole	Chassis	LA1300600	LA1300600	LA1300600	LA1300600
14	2	304S.S	Blindskruer	Plug	LA2000600	LA2000600	LA2000600	LA2000600
14a	1	304S.S	Blindskruer	Plug	LA2000500	LA2000500	LA2000500	LA2000500
15	2	AISI304	Ringbolt	Lifting Eye bolt	LA2101616	LA2101616	LA2101616	LA2101616
15a	1	AISI304	Ringbolt	Lifting Eye bolt	L773398	L773398	L773398	L773398
16	2	Nylon	Skive	Washer	L773718	L773718	L773718	L773718
16a	1	Nylon	Skive	Washer	L773654	L773654	L773654	L773654
18	2	304S.S	Clampring	Clamp ring	LA1354600	LA1354600	LA1354600	LA1354600
19	2	304S.S	Skruer for clampring	Screw for clampring	L772962	L772962	L772962	L772962
20	1	Brass	Holder for læbetætning	Seal consol	LA1301600	LA1301600	LA1301600	LA1301600
23	1	Plastic	Oliefyldningsstuds	Oil filler plug	LA2203001	LA2203001	LA2203001	LA2203001
23a	1	316	Nippelmuffe 1-3/4"	Nipple int. threaded 1-3/4"	L781064	L781064	L781064	L781064
24	4	304S.S.	Skruer, holder for læbetætning	Screw, seal consol	L773454	L773454	L773454	L773454
25	1	Plastic	Olieskueglas	Oil level window	L2221000	L2221000	L2221000	L2221000
26	1	304S.S	Tandhjulskappe	Can	LA1364600	LA1364600	LA1364600	LA1364600
27	1	Plastic	Oliedrænprop	Oil drain plug	L2210A001	L2210A001	L2210A001	L2210A001
27a	1	316	Kugleventil	Ball valve	LA2210600	LA2210600	LA2210600	LA2210600
28	4	304S.S	Klemåsemøtrik, olietætningsplade	Nut, oil seal plate	L773652	L773652	L773652	L773652
29	2	304S.S	Fod	Foot	LA1147600	LA1147600	LA1147600	LA1147600
31	4	304S.S	Skruer for fod	Screw for foot	L772568	L772568	L772568	L772568
*5, 34 & 36	1	EPDM	Produktberørt paknings kit	Wet end seal kit	LA2380604	LA2380604	LA2380604	LA2380604
-	1	FPM (Viton)	Produktberørt paknings kit	Wet end seal kit	LA2380602	LA2380602	LA2380602	LA2380602
-	1	ISOLAST	Produktberørt paknings kit	Wet end seal kit	LA2380615	LA2380615	LA2380615	LA2380615
#11, 17, 21, 22 & 42	1	FPM (Viton)	Gear boks paknings kit	Gear box seal kit	LA2381602	LA2381602	LA2381602	LA2381602

7. Pumpe komplet / Pump complete

Std. DW 6

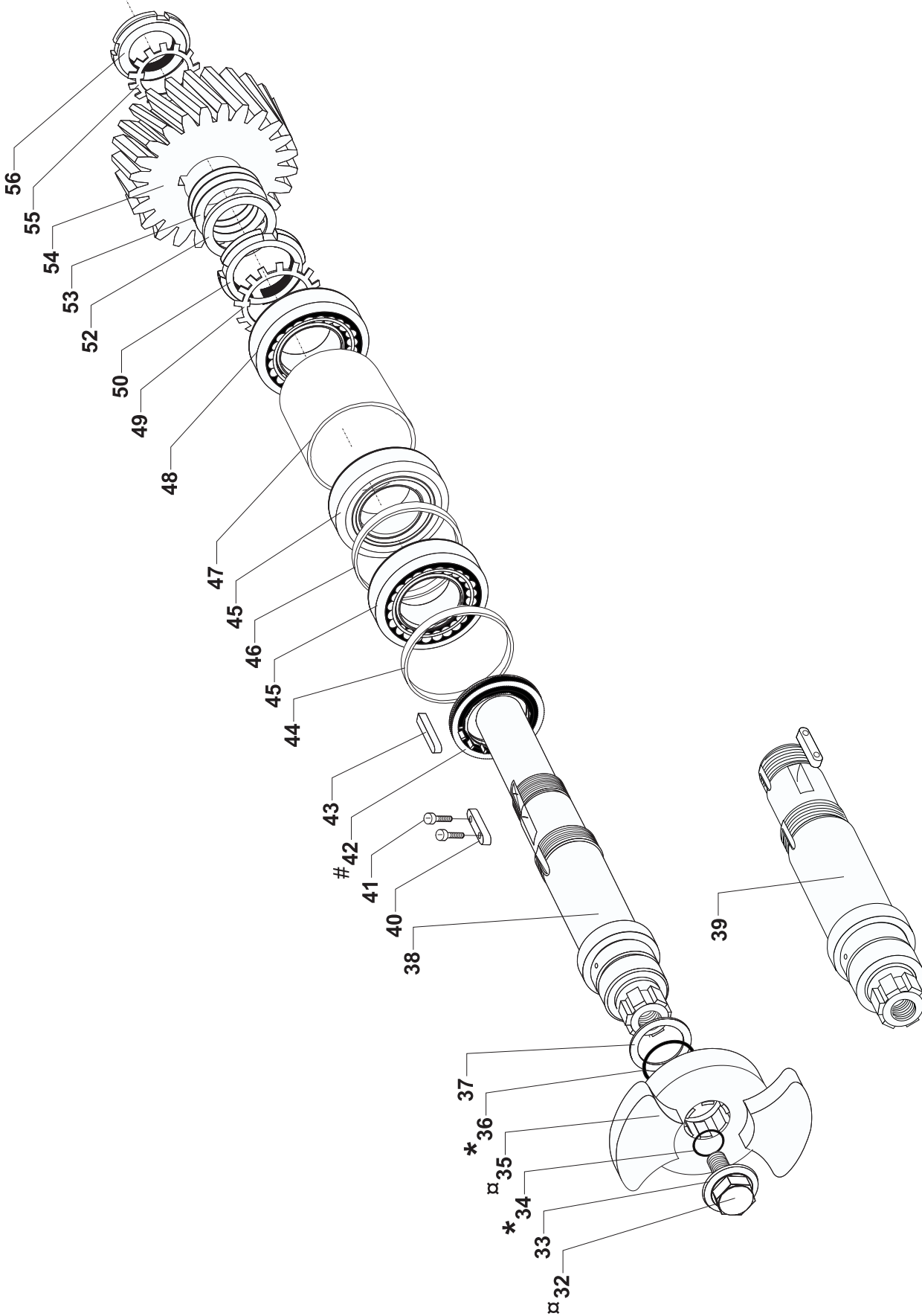

* Produkt berørt paknings kit / Wet end seal kit
 # Gear boks paknings kit / Gear box seal kit

7. Pumpe komplet / Pump complete

Std. DW 6

NB! Nedenstående er varenumre, dækker ikke pumper solgt med 3.1 certifikat.
 For 3.1 reservedele, kontakt APV.
 Part No. mentioned below, do not cover pumps sold with 3.1 certificate.
 For 3.1 spare parts, contact APV.

Pos	Stk/Qty	Material	Benævnelse	Description	Del nr. / Part No.			
					Piston DW6/172/12.5	Lobe DW6/198/30	Lobe DW6/308/15	Lobe DW6/519/7
32	2	329S.S 18/02	Rotor skrue incl friktionsring	Rotor Screw with washer	LA10506172	LA10506198	LA10506308	LA10506519
33	2		Friktionsring	Washer ring	LA2658600	LA2658600	LA2658600	LA2658601
35	2	316L	Rotor-Multi-Duty	Rotor-Multi Duty	LA146172P3SH	LA14619823SH	LA14630823SH	LA14651923SH
-	2	316L	Rotor-høj temperatur	Rotor-high temperature				
-	2	NGA	Rotor-høj temperatur	Rotor-high temperature				
-	2	NGA	Rotor-super tight	Rotor-super tight			LA14630825WH	
37	1	316S.S	Afstandsskiver, rotor	Shims, rotor	L2657600	L2657600	L2657600	L2657600
38	1	AISI329L	Drivaksel	Shaft main	LA1500600	LA1501600	LA1501600	LA1501600
39	1	AISI329L	Dreven aksel	Shaft aux	LA1600600	LA1601600	LA1601600	LA1601600
40	2	EN 6A	Feder, tandhjul	Gear key	L2180A600	L2180A600	L2180A600	L2180A600
41	4	-	Skrue, tandhjulsfeder	Screw, gear key	L701450	L701450	L701450	L701450
43	1	EN 6A	Drivfeder	Drive key	L2181A600	L2181A600	L2181A600	L2181A600
44	2	St.37-2	Lejering	Front spacer	LA1856600	LA1856600	LA1856600	LA1856600
45	4	-	Forreste leje	Bearing front	L2717600	L2717600	L2717600	L2717600
46	2	St. 37-2	Afstandscylinder,forreste leje	Spacer,front bearing	LA1860600	LA1860600	LA1860600	LA1860600
47	2	St. 37-2	Afstandscylinder,bagerste leje	Spacer,rear bearing	LA1861600	LA1861600	LA1861600	LA1861600
48	2	-	Bagerste leje	Bearing rear	L2718600	L2718600	L2718600	L2718600
49	2	-	Spændskive, bagerste leje	Bearing rear tab washer	L2720065	L2720065	L2720065	L2720065
50	2	-	Møtrik, bagerste leje	Bearing rear nut	L2719065	L2719065	L2719065	L2719065
52	2	-	Afstandscylinder, tandhjul	Gear spacer	LA1850600	LA1850600	LA1850600	LA1850600
53	1	St. 37-2	Afstandsskiver, tandhjul	Gear shims	L4000A600	L4000A600	L4000A600	L4000A600
54	1	St. 37	Tandhjul (1 par)	Gear (1 pair)	LA2750600	LA2750600	LA2750600	LA2750600
55	2	-	Spændskive, gear	Gear tab washer	L2720060	L2720060	L2720060	L2720060
56	2	-	Møtrik, gear	Gear nut	L2719060	L2719060	L2719060	L2719060

7. Pumpe komplet / Pump complete

Std. DW 7

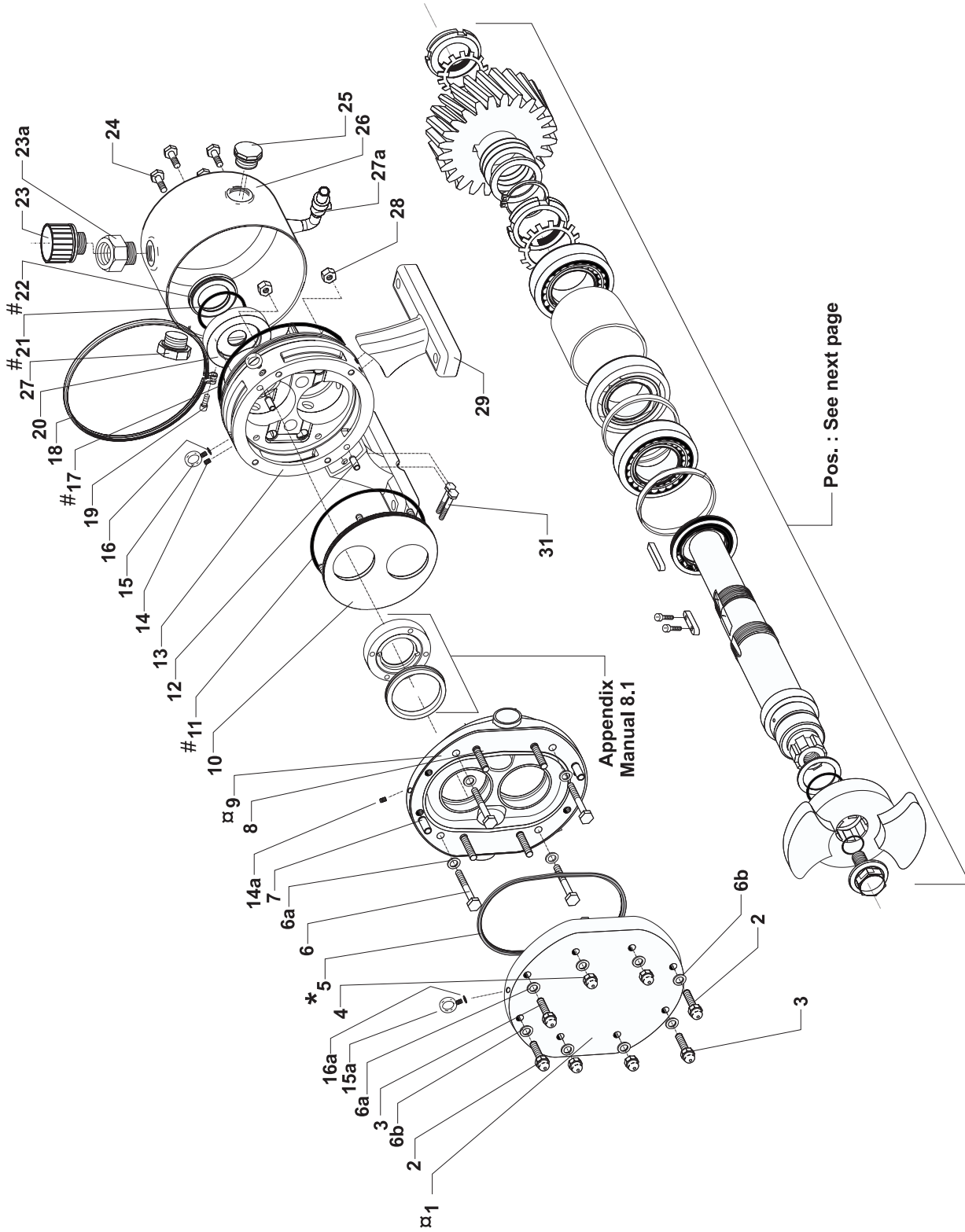

* Produkt berørt paknings kit / Wet end seal kit
 # Gear boks paknings kit / Gear box seal kit

7. Pumpe komplet / Pump complete

Std. DW 7

NBI Nedenstående α varenumre, dækker ikke pumper solgt med 3.1 certifikat.
 For 3.1 reservedele, kontakt APV.
 α Part No. mentioned below, do not cover pumps sold with 3.1 certificate.
 For 3.1 spare parts, contact APV.

Pos	Stk/Qty	Material	Benævnelse	Description	Del nr. / Part No.			
					Piston	Lobe	Lobe	Lobe
					DW71420/30	DW71725/15	DW71016/7	
α 1	1	316L	Frontdæksel	Front cover	LA1100701	LA1100700	LA1100700	LA1100700
2	2	304S.S	Stor bolt, front plade	Big bolt, front cover	LA1000700	LA1000700	LA1000700	LA1000700
3	2	304S.S	Lille bolt, front plade	Small bolt, front cover	LA1001700	LA1001700	LA1001700	LA1001700
4	4	AISI 304	Møtrik, frontplade	Nut, front cover dome	L773710	L773710	L773710	L773710
6	4	304S.S	Skrue, rotorhus/lejekonsol	Screw, rotor case to chassis	L773705	L773705	L773705	L773705
6a	10	304S.S	Skive	Washer	L773488	L773488	L773488	L773488
6b	2	304S.S	Skive	Washer	LA2176001	LA2176001	LA2176001	LA2176001
7	2	316S.S	Styrestift	Dowel	LA1160730	LA1160730	LA1160730	LA1160730
8	4	AISI 304	Støttebolt, frontplade	Stud, front cover	L773723	L773722	L773721	L773721
α 9	1	316L	Rotorhus	Rotor case	LA17087370	LA17087420	LA17087725	LA170871016
10	1	304S.S	Olietætningsplade	Oilseal plate	LA1312700	LA1312700	LA1312700	LA1312700
12	2	316S.S	Styrestift, rotorhus/lejekonsol	Dowel, rotor case to chassis	LA1160860	LA1160860	LA1160860	LA1160860
13	1	AISI 304	Lejekonsol	Chassis	LA1300700	LA1300700	LA1300700	LA1300700
14	2	304S.S	Blindskruer	Plug	LA2000700	LA2000700	LA2000700	LA2000700
14a	1	304S.S	Blindskruer	Plug	LA2000500	LA2000500	LA2000500	LA2000500
15	2	AISI 304	Ringbolt	Lifting Eye bolt	LA2101720	LA2101720	LA2101720	LA2101720
15a	1	AISI 304	Ringbolt	Lifting Eye bolt	L773398	L773398	L773398	L773398
16	2	Nylon	Skive	Washer	L773713	L773713	L773713	L773713
16a	1	Nylon	Skive	Washer	L773654	L773654	L773654	L773654
18	2	304S.S	Clampring	Clamp ring	LA1354700	LA1354700	LA1354700	LA1354700
19	2	304S.S	Skrue for clampring	Screw for clampring	L772962	L772962	L772962	L772962
20	1	Brass	Holder for læbetætning	Seal consol	LA1301700	LA1301700	LA1301700	LA1301700
23	1	Plastic	Oliefyldningsstuds	Oil filler plug	LA2203001	LA2203001	LA2203001	LA2203001
23a	1	316	Nippelmuffe 1-3/4"	Nipple int. threaded 1-3/4"	L781064	L781064	L781064	L781064
24	4	304S.S.	Skrue, Holder for læbetætning	Screw, Seal consol	L773455	L773455	L773455	L773455
25	1	Plastic	Olieskueglas	Oil level window	L2221000	L2221000	L2221000	L2221000
26	1	304S.S	Tandhjulskappe	Can	LA1364700	LA1364700	LA1364700	LA1364700
27	1	Plastic	Oliedrænprop	Oil drain plug	L2210A001	L2210A001	L2210A001	L2210A001
27a	1	316	Kugleventil	Ball valve	LA2210600	LA2210600	LA2210600	LA2210600
28	4	304S.S	Klemålsemøtrik, olietætningsplade	Nut, oil seal plate	L773652	L773652	L773652	L773652
29	2	304S.S	Fod	Foot	LA1147700	LA1147700	LA1147700	LA1147700
31	4	304S.S	Skrue for fod	Screw for foot	L773704	L773704	L773704	L773704
*5, 34 & 36	1	EPDM	Produktberørt paknings kit	Wet end seal kit	LA2380704	LA2380704	LA2380704	LA2380704
-	1	FPM (Viton)	Produktberørt paknings kit	Wet end seal kit	LA2380702	LA2380702	LA2380702	LA2380702
-	1	ISOLAST	Produktberørt paknings kit	Wet end seal kit	LA2380715	LA2380715	LA2380715	LA2380715
#11, 17, 21, 22 & 42	1	FPM (Viton)	Gear boks paknings kit	Gear box seal kit	LA2381702	LA2381702	LA2381702	LA2381702

7. Pumpe komplet / Pump complete

Std. DW 7

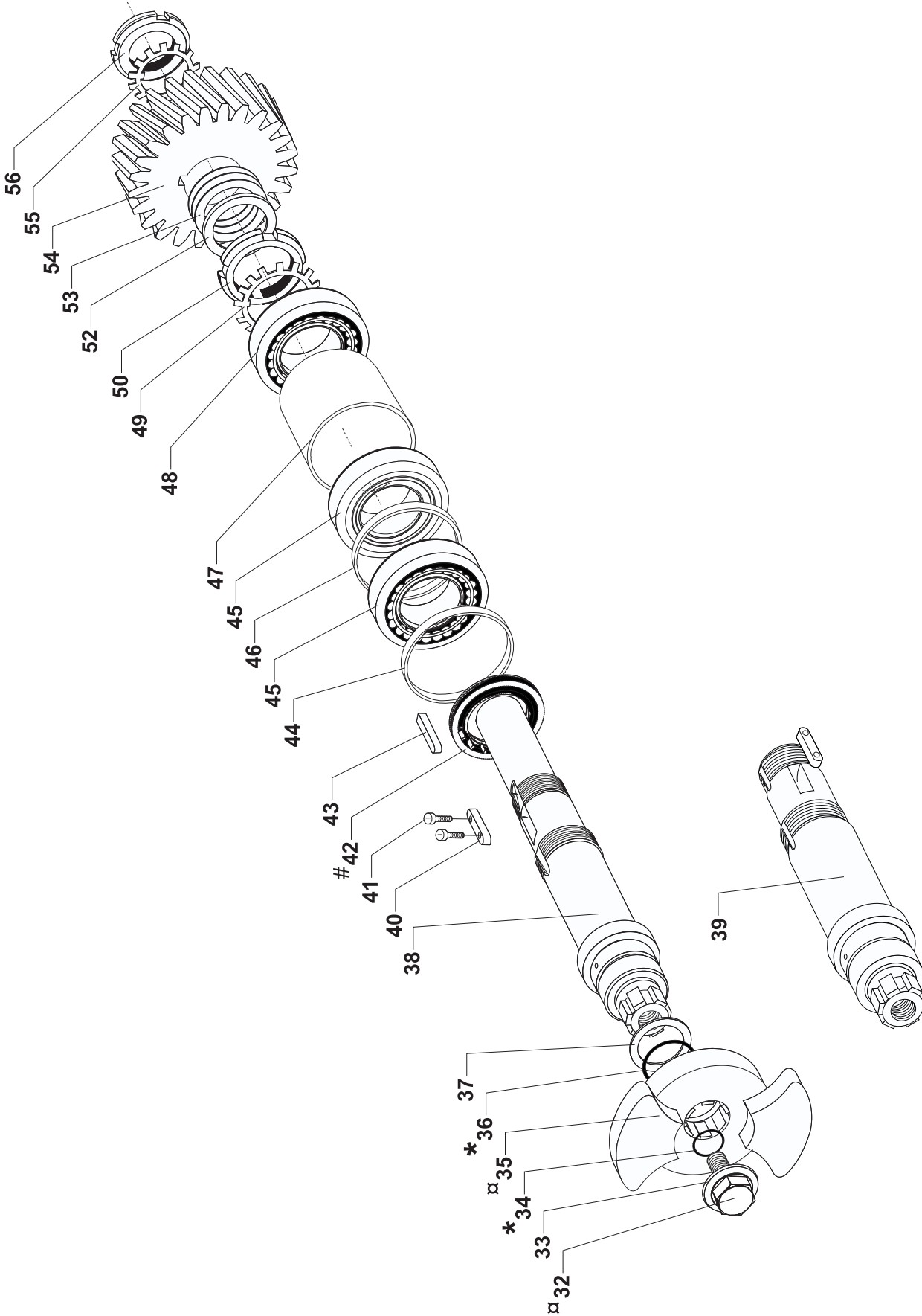

* Produkt berørt paknings kit / Wet end seal kit
 # Gear boks paknings kit / Gear box seal kit

7. Pumpe komplet / Pump complete

Std. DW 7

NB! Nedenstående er varenumre, dækker ikke pumper solgt med 3.1 certifikat.
 For 3.1 reservedele, kontakt APV.
 Part No. mentioned below, do not cover pumps sold with 3.1 certificate.
 For 3.1 spare parts, contact APV.

Pos	Stk/Qty	Material	Benævnelse	Description	Del nr. / Part No.			
					Piston DW7/370/10	Lobe DW7/420/30	Lobe DW7/725/15	Lobe DW7/1016/7
32	2	329S.S	Rotor skrue incl friktionsring	Rotor Screw with washer	LA10507370	LA10507420	LA10507725	LA105071016
33	2	18/02	Friktionsring	Washer ring	LA2658700	LA2658700	LA2658700	LA2658701
35	2	316L	Rotor-Multi-Duty	Rotor-Multi Duty	LA147370P3SH	LA14742023SH	LA14772523SH	LA147101623SH
-	2	316L	Rotor-høj temperatur	Rotor-high temperature				
-	2	NGA	Rotor-høj temperatur	Rotor-high temperature				
-	2	NGA	Rotor-super tight	Rotor-super tight				
37	1	316S.S	Afstandsskiver, rotor	Shims, rotor	L2657700	L2657700	L2657700	L2657700
38	1	AISI329L	Drivaksel	Shaft main	LA1500700	LA1501700	LA1501700	LA1501700
39	1	AISI329L	Dreven akse	Shaft aux	LA1600700	LA1601700	LA1601700	LA1601700
40	2	EN 6A	Feder, tandhjul	Gear key	L2180A700	L2180A700	L2180A700	L2180A700
41	4	-	Skrue, tandhjulsfeder	Screw, gear key	L701450	L701450	L701450	L701450
43	1	EN 6A	Drivfeder	Drive key	L2181A700	L2181A700	L2181A700	L2181A700
44	2	St.37-2	Lejering	Front spacer	LA1856700	LA1856700	LA1856700	LA1856700
45	4	-	Forreste leje	Bearing front	L2717700	L2717700	L2717700	L2717700
46	2	St. 37-2	Afstandscylinder, forreste leje	Spacer, front bearing	LA1860700	LA1860700	LA1860700	LA1860700
47	2	St. 37-2	Afstandscylinder, bagerste leje	Spacer, rear bearing	LA1861700	LA1861700	LA1861700	LA1861700
48	4	-	Bagerste leje	Bearing rear	L2718700	L2718700	L2718700	L2718700
49	4	-	Spændskive, bagerste leje	Bearing rear tab washer	L2720085	L2720085	L2720085	L2720085
50	2	-	Møtrik, bagerste leje	Bearing rear nut	L2719085	L2719085	L2719085	L2719085
52	2	St. 37-2	Afstandscylinder, tandhjul	Gear spacer	LA1850700	LA1850700	LA1850700	LA1850700
53	1	St. 37	Afstandsskiver, tandhjul	Gear shims	L4000400	L4000400	L4000400	L4000400
54	1	-	Tandhjul (1 par)	Gear (1 pair)	LA2750700	LA2750700	LA2750700	LA2750700
55	2	-	Spændskive, tandhjul	Gear tab washer	L2720075	L2720075	L2720075	L2720075
56	2	-	Møtrik, tandhjul	Gear nut	L2719075	L2719075	L2719075	L2719075

7. Akseltætning / Shaft seal

DW1-5

DW1 - 5 Enkelt mekanisk akseltætning Single mechanical seal

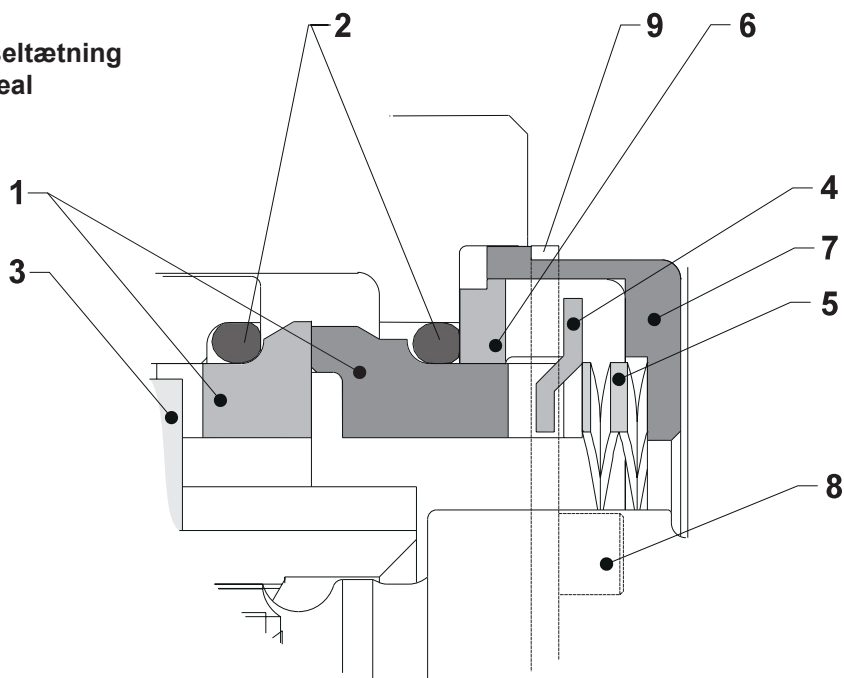

Pos.	Stk./Qty.	Material	Benævnelse	Description	Pumpe type / Pump type				
					DW1	DW2	DW3	DW4	DW5
					Del nr. / Part No.				
1 & 2	1	SiC/C-EPDM	Seal face kit*	Seal face Kit*	LA2355104	LA2355204	LA2355304	LA2355404	LA2355504
1 & 2	1	SiC/SiC-EPDM	Seal face kit*	Seal face Kit*	LA2356104	LA2356204	LA2356304	LA2356404	LA2356504
2	1	EPDM	O-rings kit	O-ring kit	LA2310104	LA2310204	LA2310304	LA2310404	LA2310504
1 & 2	1	SiC/C-FPM (Viton)	Seal face kit*	Seal face Kit*	LA2355102	LA2355202	LA2355302	LA2355402	LA2355502
1 & 2	1	SiC/SiC-FPM (Viton)	Seal face kit*	Seal face Kit*	LA2356102	LA2356202	LA2356302	LA2356402	LA2356502
2	1	FPM (Viton)	O-rings kit	O-ring kit	LA2310102	LA2310202	LA2310302	LA2310402	LA2310502
1 & 2	1	SiC/C-ISOLAST	Seal face kit*	Seal face Kit*	LA2355115	LA2355215	LA2355315	LA2355415	LA2355515
1 & 2	1	SiC/SiC-ISOLAST	Seal face kit*	Seal face Kit*	LA2356115	LA2356215	LA2356315	LA2356415	LA2356515
2	1	ISOLAST	O-rings kit	O-ring kit	LA2310115	LA2310215	LA2310315	LA2310415	LA2310515
3, 4 & 5	1	SS	Seal service kit**	Seal service kit**	LA2304100	LA2304200	LA2304300	LA2304400	LA2304500
6	1	AISI 304	Ring for tætning	Ring for seal	LA2363101	LA2363201	LA2363301	LA2363401	LA2363501
7	1	AISI 304	Tætningshus	Seal Housing	LA2363102	LA2363202	LA2363302	LA2363402	LA2363502
9	2	AISI 304	Clamp for tætningshus	Clamp, seal housing	LA2363100	LA2363200	LA2363300	LA2363400	LA2363500
8	4	304S.S	Skrue, tætningshus	Screw, seal housing	L770496	L770496	L770496	L701227	L701227

NOTE: Der indgår til en pumpe det dobbelte antal = de valgte dele x 2
For a pump twice the number are required = the parts chosen x 2.

* Seal Face Kit : Statorring, rotorring (1) og 2 O-ringe (2)
Stationary seal face, rotary seal face (1) and 2 off O-rings (2)

** Seal Service Kit : Rotor og stator drivring (3 & 4) & fjeder (5)
Rotary and stationary drive ring (3 & 4) and spring (5)

7. Akseltætning / Shaft seal

DW6-7

DW6 - 7
 Enkelt mekanisk akseltætning
 Single mechanical seal

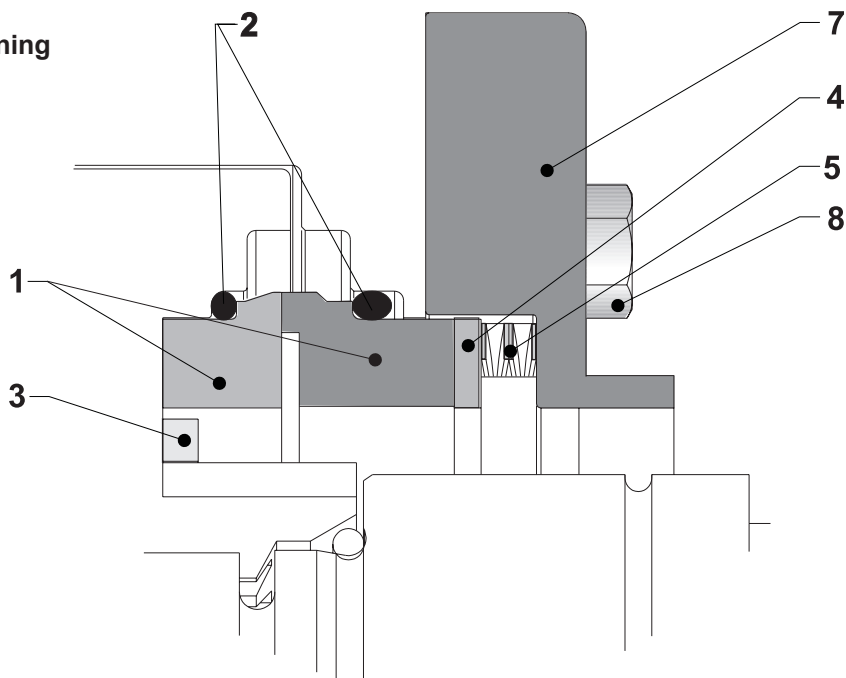

Pos.	Stk./Qty.	Material	Benævnelse	Description	Pumpe type / Pump type		
					DW6	DW7 (lobe)	DW7 (piston)
					Del nr. / Part No.		
1 & 2	1	SiC/C-EPDM	Seal face kit*	Seal face Kit*	LA2355604	LA2355704	LA2355704
1 & 2	1	SiC/SiC-EPDM	Seal face kit*	Seal face Kit*	LA2356604	LA2356704	LA2356704
2	1	EPDM	O-rings kit	O-ring kit	LA2310604	LA2310704	LA2310704
1 & 2	1	SiC/C-FPM (Viton)	Seal face kit*	Seal face Kit*	LA2355602	LA2355702	LA2355702
1 & 2	1	SiC/SiC-FPM (Viton)	Seal face kit*	Seal face Kit*	LA2356602	LA2356702	LA2356702
2	1	FPM (Viton)	O-rings kit	O-ring kit	LA2310602	LA2310702	LA2310702
1 & 2	1	SiC/C-ISOLAST	Seal face kit*	Seal face Kit*	LA2355615	LA2355715	LA2355715
1 & 2	1	SiC/SiC-ISOLAST	Seal face kit*	Seal face Kit*	LA2356615	LA2356715	LA2356715
2	1	ISOLAST	O-rings kit	O-ring kit	LA2310615	LA2310715	LA2310715
3, 4 & 5	1	SS	Seal service kit**	Seal service kit**	LA2304600	LA2304700	LA2304700
7	1	AISI 304	Tætningshus	Seal Housing	LA1200601	LA1200701	LA1200701
8	4	304S.S	Skrue, akseltætningshus	Screw, seal housing	L700234	L756001	L701380

NOTE: Der indgår til en pumpe det dobbelte antal = de valgte dele x 2
 For a pump twice the number are required = the parts chosen x 2.

* Seal Face Kit : Statorring, rotorring (1) og 2 O-ringe (2)
 Stationary seal face, rotary seal face (1) and 2 off O-rings (2)

** Seal Service Kit : Rotor og stator drivring (3 & 4) & fjeder (5)
 Rotary and stationary drive ring (3 & 4) and spring (5)

7. Bundramme / Baseplate

Type 1

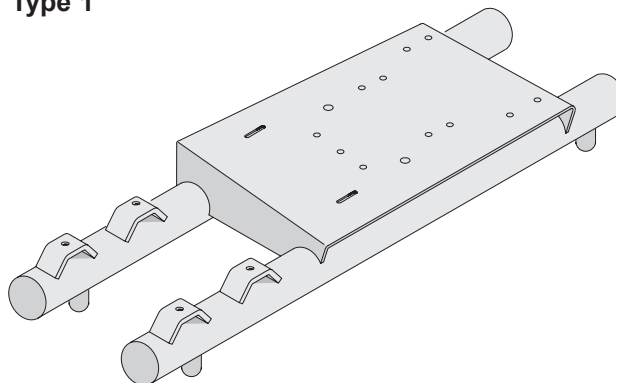

	DW1	DW2	DW3	DW4	DW5
	Del nr. / Part No.				
Type 1	LA2760100	LA2760200	LA2760300	LA2760400	LA2760500

Type 2

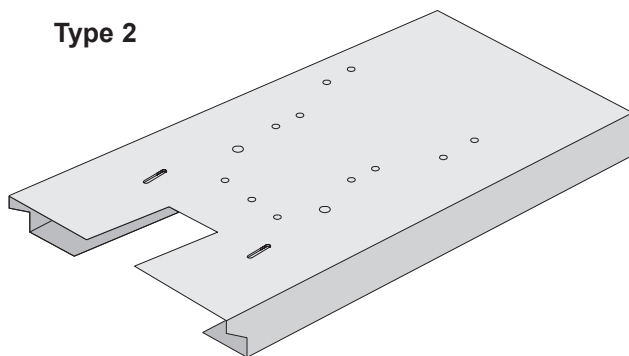

	DW1	DW2	DW3	DW4	DW5	DW6 max. 11 kW
	Del nr. / Part No.					
Type 2	LA2764100	LA2764200	LA2764300	LA2764400	LA2764500	LA2764600
						LA2764601**





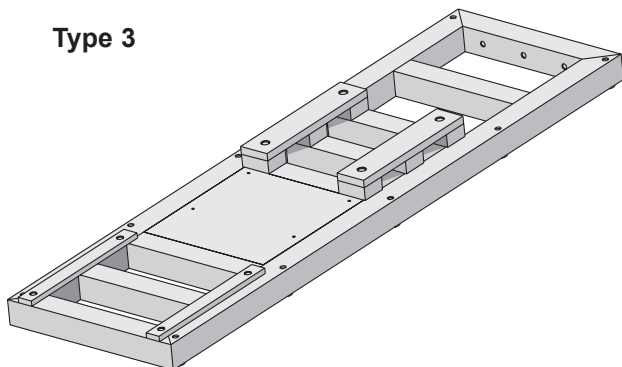



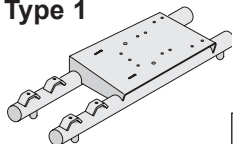

** skal bruges, når akslen er monteret til højre
must be used, when the shaft is monted to the right

Type 3









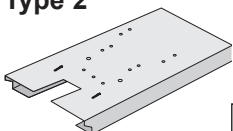



	DW6	DW7
	Del nr. / Part No.	
Type 3	LA2765xxx *	LA2765xxx *





Motorkappe komplet / Motorshroud complete
DW1-7
Type 1

	DW1		DW2		DW3		DW4		DW5	
Ind-/udløbs position / In-/outlet position										
Gear strl. / Gear size*	Del nr. / Part No.									
SK172 (320)	LAK2500100	LAK3050100	LAK3052200	LAK3052200						
SK272 & 372 (420)	LAK2501100	LAK3051100	LAK3052200	LAK3052200	LAK3601300	LAK3601300	LAK3603400	LAK3603400	LAK4506500	LAK4506500
SK472 & 572 (620)			LAK3600200	LAK3600200	LAK3601300	LAK3601300	LAK4505400	LAK4505400	LAK4507500	LAK4507500
SK672					LAK4501300	LAK3602300	LAK4505400	LAK4505400	LAK4507500	LAK4507500
SK772					LAK4501300	LAK4501300	LAK4801400	LAK4801400	LAK5251500	LAK5251500
SK872					LAK4503300	LAK4503300	LAK4804400	LAK4803400	LAK5251500	LAK5251500
SK972									LAK7001500	LAK7001500

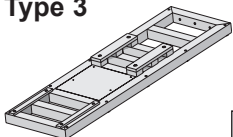
Type 2

	DW1		DW2		DW3		DW4		DW5	
Ind-/udløbs position / In-/outlet position										
Gear strl. / Gear size*	Del nr. / Part No.									
SK172 (320)	LAK2500100	LAK3050100	LAK3052200	LAK3052200						
SK272 & 372 (420)	LAK2501100	LAK3051100	LAK3052200	LAK3052200	LAK3601300	LAK3601300	LAK3603400	LAK3603400	LAK4508500	LAK4508500
SK472 & 572 (620)			LAK3600200	LAK3600200	LAK3601300	LAK3601300	LAK3603400	LAK4505400	LAK4509500	LAK4509500
SK672					LAK4501300	LAK3602300	LAK3603400	LAK4505400	LAK4509500	LAK4509500
SK772					LAK4501300	LAK4501300	LAK4802400	LAK4801400	LAK5251500	LAK5251500
SK872					LAK4800300	LAK4503300	LAK4804400	LAK4803400	LAK5251500	LAK5251500
SK972									LAK7001500	LAK7001500

Type 3

	DW6		DW7	
Ind-/udløbs position / In-/outlet position				
Gear strl. / Gear size*	Del nr. / Part No.			
SK472 & 572 (620)				
SK672				
SK772	#	#	#	#
SK872				
SK972				

* Gearmotorfabrikant / Gear motor maker: NORD

Kontakt APV for motorkapper til DW6 og DW7 / Contact APV for DW6 and DW7 shrouds

7. Motorkappe stykliste / Motorshroud spare parts

Type 1

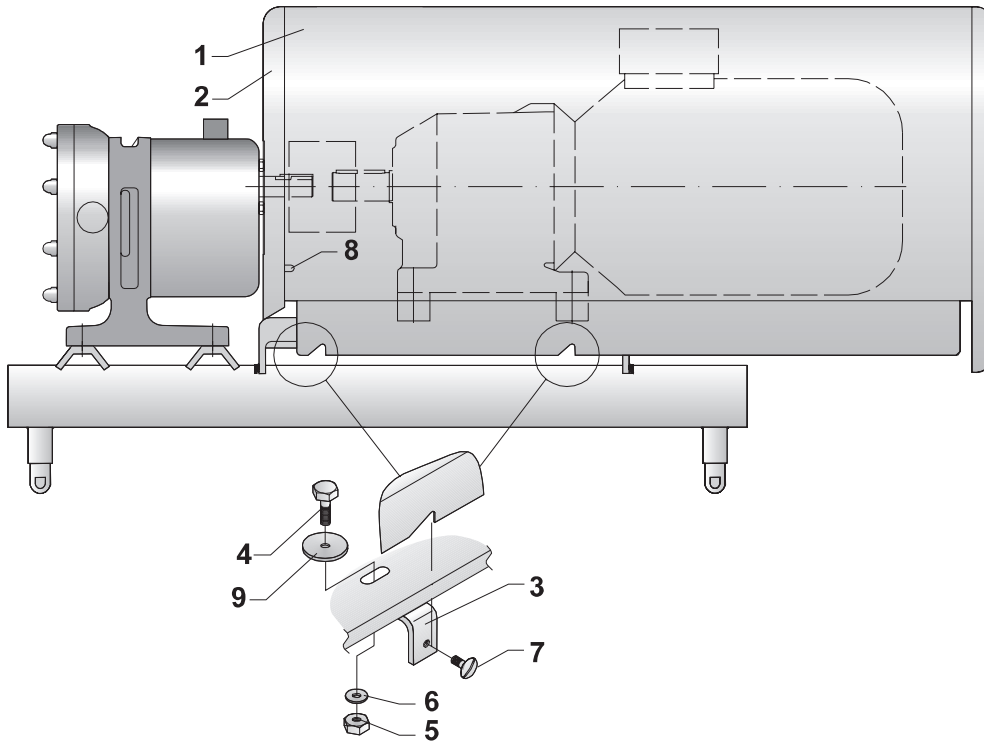

Type 2

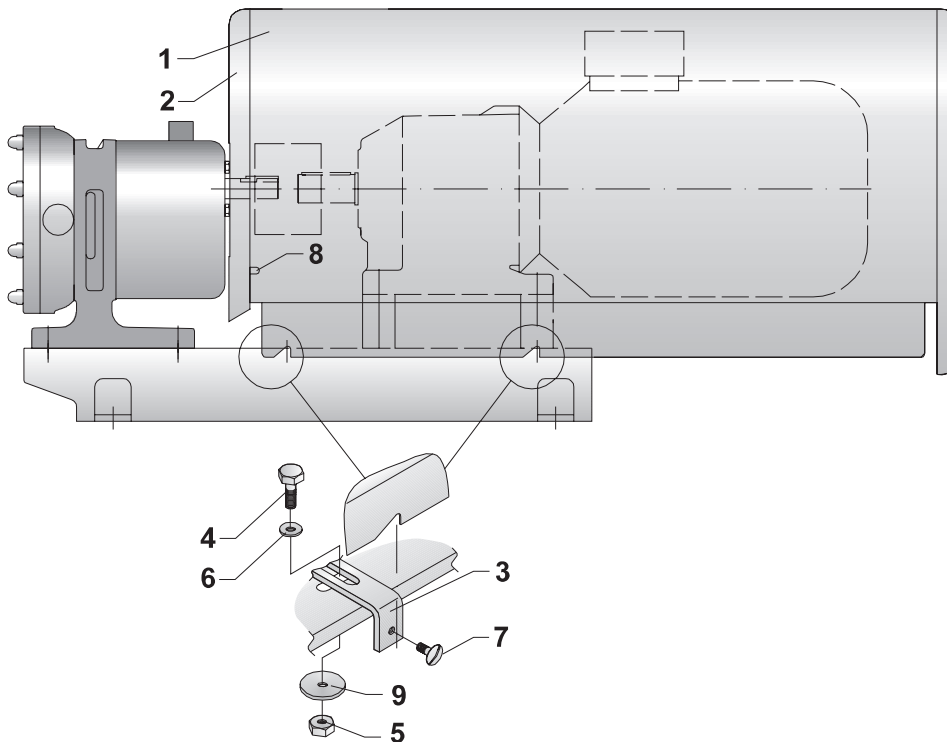

7. Motorkappe styklister / Motorshroud spare parts

Pos.	Stk./Qty.	Benævnelse	Description	DW1				DW2	
				Del nr. / Part No.					
1-9	1	Kappe komplet	Shroud complete	LAK2500100	LAK2501100	LAK3050100	LAK3051100	LAK3052200	LAK3600200
1	1	Kappe	Shroud	LA2775001	LA2775001	LA2775002	LA2775002	LA2775002	LA2775004
2	1	Dæksel	Cover	LA2776011	LA2776011	LA2776002	LA2776002	LA2776013	LA2776003
3	1	Beslag	Bracket	LA2770223	LA2770223	LA2770272	LA2770272	LA2770272	LA2770321
1	1								LA2771321
4	2	Skruer, beslag	Screws, bracket	L707608	L707608	L707608	L707608	L707608	L707608
4	4								
5	2	Møtrik, beslag	Nut, bracket	L700240	L700240	L700240	L700240	L700240	L700240
4	4								
6	2	Skive, beslag	Washer, bracket	L255550	L255550	L255550	L255550	L255550	L255550
4	4								
7	4	Skruer, kappe	Screws, bracket	L700420	L700420	L700420	L700420	L700420	L700420
8	2	Skruer, kappe	Screws, bracket	L773113	L773113	L773113	L773113	L773113	L773113
4	4								
9	2	Skive, beslag	Washer, bracket	L255550		L255550		L773464	

Pos.	Stk./Qty.	Benævnelse	Description	DW3				DW4						
				Del nr. / Part No.										
1-9	1	Kappe komplet	Shroud complete	LAK3601300	LAK3602300	LAK4501300	LAK4503300	LAK4800300	LAK3603400	LAK4505400	LAK4801400	LAK4802400	LAK4803400	LAK4804400
1	1	Kappe	Shroud	LA2775006	LA2775011	LA2775007	LA2775007	LA2775010	LA2775011	LA2775007	LA2775009	LA2775009	LA2775009	LA2775009
2	1	Dæksel	Cover	LA2776003	LA2776003	LA2776001	LA2776001	LA2776007	LA2776005	LA2776006	LA2776007	LA2776007	LA2776007	LA2776007
3	1	Beslag	Bracket	LA2771321	LA2771321	LA2771357	LA2770357	LA2770357	LA2771382	LA2771382	LA2772321	LA2771357	LA2771382	LA2772382
1	1													
2	2													
4	2	Skruer, beslag	Screws, bracket	L707608	L707608	L707608	L707608	L707608	L707608	L707608	L707608	L707608	L707608	L707608
4	4													
5	2	Møtrik, beslag	Nut, bracket	L700240	L700240	L700240	L700240	L700240	L700240	L700240	L700240	L700240	L700240	L700240
4	4													
6	2	Skive, beslag	Washer, bracket	L255550	L255550	L255550	L255550	L255550	L255550	L255550	L255550	L255550	L255550	L255550
4	4													
7	4	Skruer, kappe	Screws, bracket	L700420	L700420	L700420	L700420	L700420	L700420	L700420	L700420	L700420	L700420	L700420
8	2	Skruer, kappe	Screws, bracket	L773113	L773113	L773113	L773113	L773113	L773113	L773113	L773113	L773113	L773113	L773113
4	4													
9	2	Skive, beslag	Washer, bracket	L773464	L773464	L773464			L773464	L773464	L773464	L773464	L773464	L773464
8	8													

Pos.	Stk./Qty.	Benævnelse	Description	DW5				DW6*		DW7*	
				Del nr. / Part No.							
1-9	1	Kappe komplet	Shroud complete	LAK4506500	LAK4507500	LAK4508500	LAK4509500	LAK5251500	LAK7001500		
1	1	Kappe	Shroud	LA2775012	LA2775007	LA2775012	LA2775007	LA2775013	LA2775014		
2	1	Dæksel	Cover	LA2776008	LA2776008	LA2776008	LA2776008	LA2776009	LA2776010		
3	1	Beslag	Bracket	LA2771357	LA2771357	LA2771357	LA2771357	LA2771357	LA2771357	LA2771357	LA2771357
1	1										
2	2										
4	2	Skruer, beslag	Screws, bracket	L700678	L700678	L700678	L700678	L700678	L700678	L700678	L700678
2	2										
5	2	Møtrik, beslag	Nut, bracket	L701670	L701670	L701670	L701670	L701670	L701670	L701670	L701670
4	4										
6	2	Skive, beslag	Washer, bracket	L773488	L773488	L773488	L773488	L773488	L773488	L773488	L255550
4	4										
7	4	Skruer, kappe	Screws, bracket	L700420	L700420	L700420	L700420	L700420	L700420	L700420	L700420
8	4	Skruer, kappe	Screws, bracket	L773113	L773113	L773113	L773113	L773113	L773113	L773113	L773113

* Kontakt APV for motorkapper til DW6 og DW7 / Contact APV for DW6 and DW7 shrouds

7. Koblingskappe / Coupling Guard

DW1-5

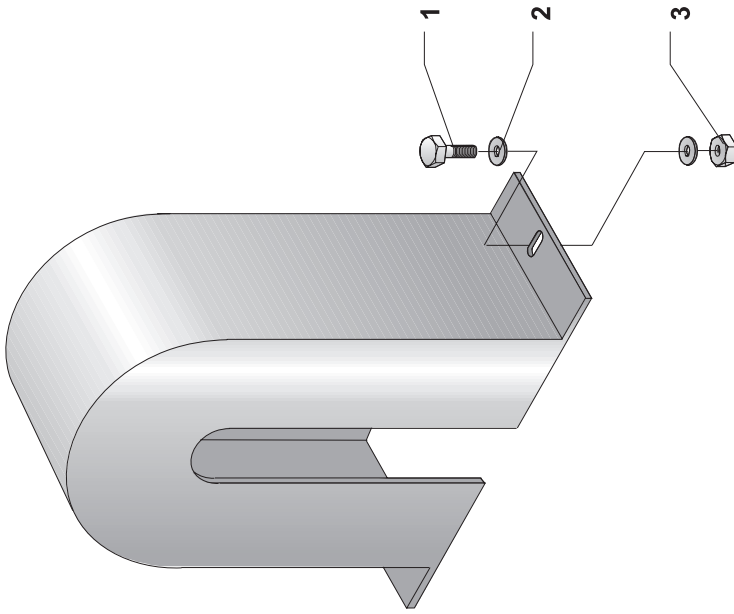

Pos	Benævneelse Description	Stk Qty	DW1	DW2	DW3	DW4	DW5	DW6	DW7
1	Skru/Screw	2	L705856	L705856	L705856	L705856	L705856	*L700233	
2	Skive/Washer	4	L701477	L701477	L701477	L701477	L701477	**L701478	#
3	Møtrik/Nut	2	L700240	L700240	L700240	L700240	L700240	***L700241	

* 4 stk. skruer / 4 off screws

** 8 stk. skiver / 8 off washers

*** 4 stk. møtrikker / 4 off nuts

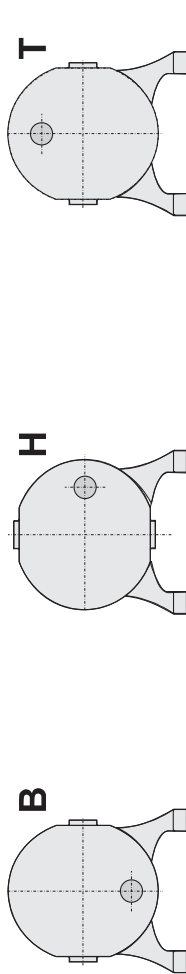

Aksel monteret i Bund /
Shaft mounted in Bottom

Aksel monteret til Højre /
Shaft mounted Horizontal (Right)

Aksel monteret i Top /
Shaft mounted in Top

Type 1

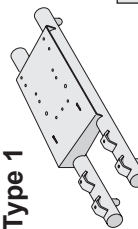

Ind-/udløbs position / In-/outlet position	DW1		DW2		DW3		DW4		DW5		Del nr. / Part No.
	B	H	B	T	B	T	B	T	B	T	
Gear str. / Gear size*	LA2780101	LA2780101	LA2780201	LA2780201	LA2780301	LA2780301	LA2780410	LA2780410	LA2780520	LA2780520	LA2780521
SK172 (320)	LA2780102	LA2780102	LA2780206	LA2780206	LA2780307	LA2780307	LA2780413	LA2780413	LA2780522	LA2780522	LA2780523
SK272 & 372 (420)			LA2780205	LA2780207	LA2780308	LA2780303	LA2780415	LA2780415	LA2780524	LA2780524	LA2780525
SK472 & 572 (620)					LA2780310	LA2780305	LA2780416	LA2780417	LA2780532	LA2780532	LA2780527
SK672					LA2780309	LA2780313	LA2780418	LA2780419	LA2780528	LA2780529	LA2780528
SK772									LA2780530	LA2780530	LA2780531
SK872											
SK972											

7. Koblingskappe / Coupling Guard

DW1-7

Type 2

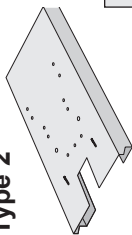

Ind-/udløbs position / In-/outlet position	DW1		DW2		DW3		DW4		DW5	
	B	H	B	H	B	H	B	H	B	H
Gear str. / Gear size*	LA2780101	LA2780101	LA2780202	LA2780203	LA2780306	LA2780306	LA2780410	LA2780413	LA2780520	LA2780521
SK272 & 372 (420)	LA2780102	LA2780102	LA2780206	LA2780204	LA2780307	LA2780307	LA2780411	LA2780412	LA2780522	LA2780523
SK472 & 572 (620)			LA2780207	LA2780205	LA2780304	LA2780308	LA2780414	LA2780415	LA2780524	LA2780525
SK672					LA2780311	LA2780310	LA2780417	LA2780417	LA2780526	LA2780527
SK772					LA2780312	LA2780313	LA2780418	LA2780419	LA2780529	LA2780529
SK872									LA2780530	LA2780531
SK972										

Del nr. / Part No.

Type 3

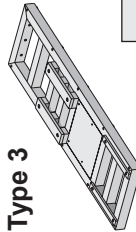

Ind-/udløbs position / In-/outlet position	DW6		DW7	
	B	H	B	H
Gear str. / Gear size*	LA27806772	LA27806872	LA27806621	LA27806621
SK472 & 572 (620)	LA27806872	LA27806872	LA2780662	LA2780662
SK772	LA27806972	LA27806972	LA2780662	LA2780662
SK872			LA2780662	LA2780662
SK972			LA2780662	LA2780662
SK52			LA2780692	LA2780692
SK62 max. 37 kW				
SK62 min. 45 kW				
SK72				
SK82				
SK92				
SK102				

Type 2

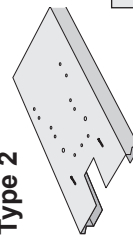

Ind-/udløbs position / In-/outlet position	DW6 max. 11 kW	
	B	H
Gear str. / Gear size*	LA2780672	LA27806721
SK472 & 572 (620)	LA2780672	LA27806721
SK672		
SK772		
SK872		

* Gearmotorfabrikant / Gear motor maker: NORD

Kontakt APV for koblingskapper til DW6 og DW7 / Contact APV for DW6 and DW7 coupling guards

7. Pumpens mål / Pump dimensions

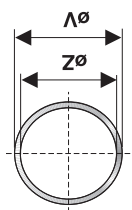

Inlet / Outlet detail Q
Indløb / Udløb detalje Q

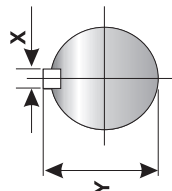

Keyway details
Drivfeder detalje

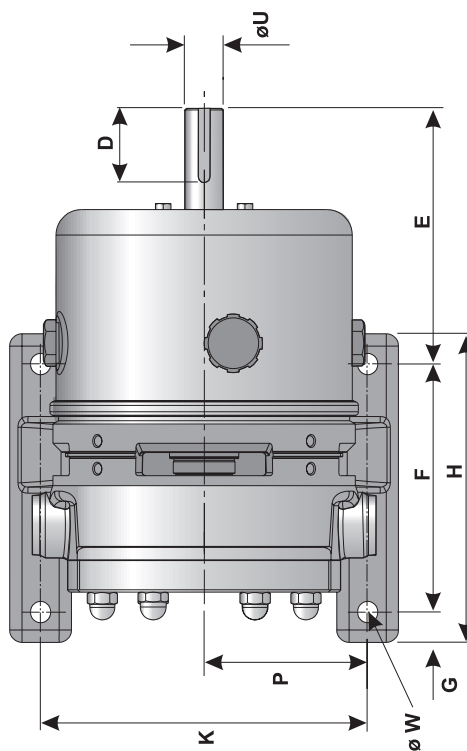
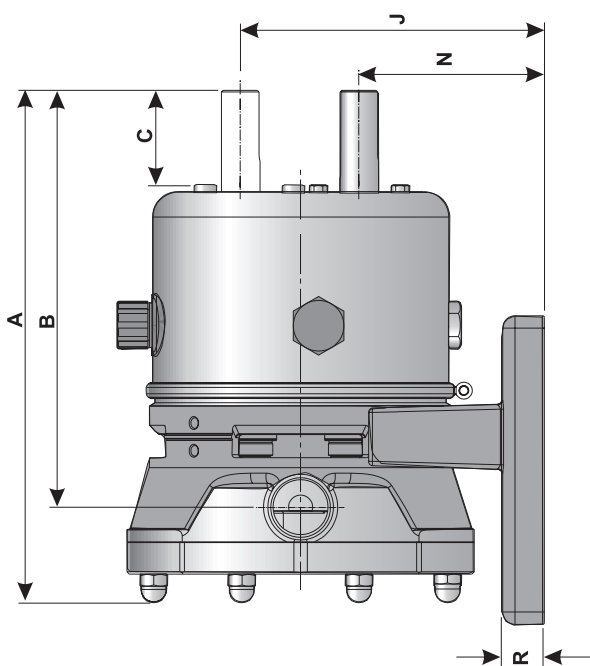
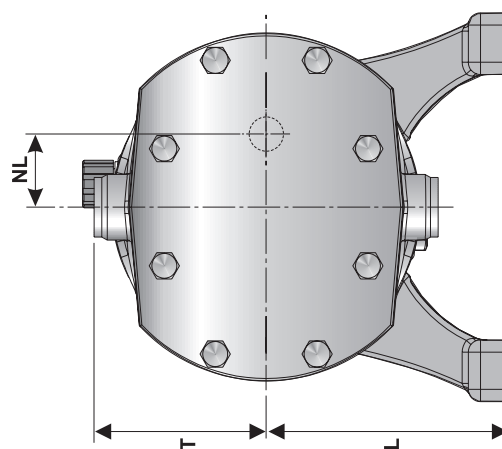
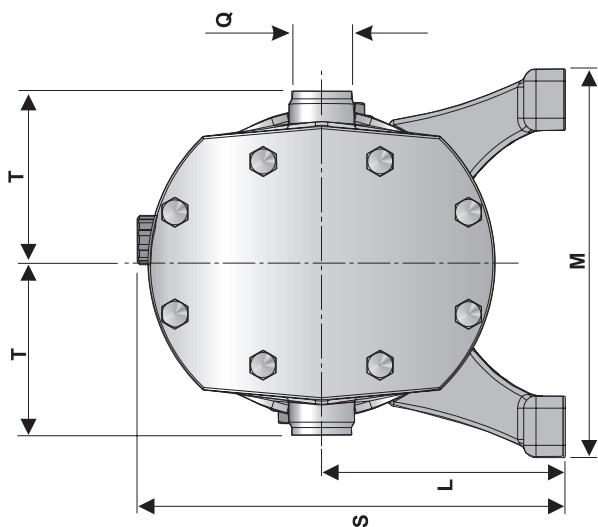

7. Pumpens mål / Pump dimensions

Pump model	A	B	C	D	E	F	G	H	J	K	L	M	N	NL	P	Q	R	S	T	U	W	X	Y	Z	V	Netto vægt (kg) Nett weight (kg)	Olie kapacitet (liter) Oil capacity (litres)
DW1/003/-	260	217.2	40	38	109	121	12.5	146	150	166	122	193	94	28	83	DN15	19	218	86	ø18	ø8.5	6	20.5	16.0	19.0	17	0.8
DW1/004/-	260	217.2	40	38	109	121	12.5	146	150	166	122	193	94	28	83	DN15	19	218	86	ø18	ø8.5	6	20.5	16.0	19.0	17	0.8
DW1/007/-	268	222.5	40	38	109	121	12.5	146	150	166	122	193	94	28	83	1"	19	218	86	ø18	ø8.5	6	20.5	22.6	25.6	18	0.8
DW2/006/-	297	248	50	36	120	142	17	176	178	194	145	228	112	33	97	1"	20	252	98	ø22	ø12	6	24.5	22.6	25.6	25.5	1.3
DW2/007/-	297	248	50	36	120	142	17	176	178	194	145	228	112	33	97	1"	20	252	98	ø22	ø12	6	24.5	22.6	25.6	25.5	1.3
DW2/013/-	307	252	50	36	120	142	17	176	178	194	145	228	112	33	97	1½"	20	252	98	ø22	ø12	6	24.5	35.6	38.6	27	1.3
DW3/014/-	332	271	60	40	123	160	20	200	196	212	158	252	120	38	106	1½"	24	273	112	ø25	ø13	8	28	35.6	38.6	34	1.4
DW3/017/-	332	271	60	40	123	160	20	200	196	212	158	252	120	38	106	1½"	24	273	112	ø25	ø13	8	28	35.6	38.6	34	1.4
DW3/030/-	348	280	60	40	123	160	20	200	196	212	158	252	120	38	106	2"	24	273	112	ø25	ø13	8	28	48.6	51.6	40	1.4
DW3/050/-	372	304	60	40	123	160	20	200	196	212	158	252	120	38	106	2"	24	273	112	ø25	ø13	8	28	48.6	51.6	45	1.4
DW4/033/-	423	352	80	45	162	205	20	245	238	260	190	300	142	48	130	2"	24	328	130	ø35	ø14	10	38	48.6	51.6	64	3.0
DW4/039/-	423	352	80	45	162	205	20	245	238	260	190	300	142	48	130	2"	24	328	130	ø35	ø14	10	38	48.6	51.6	64	3.0
DW4/073/-	449	365	80	45	162	205	20	245	238	260	190	300	142	48	130	3"	24	328	130	ø35	ø14	10	38	72.9	76.7	72	3.0
DW4/125/-	489	399	80	45	162	205	20	245	238	260	190	300	142	48	130	3"	24	328	130	ø35	ø14	10	38	72.9	76.7	85	3.0
DW5/080/-	565	479	106	71	232	262	25	312	303	326	240	376	177	63	163	2½"	33	434	165	ø42	ø17	12	45	60.3	64.1	151	7.0
DW5/093/-	565	479	106	71	232	262	25	312	303	326	240	376	177	63	163	2½"	33	434	165	ø42	ø17	12	45	60.3	64.1	151	7.0
DW5/142/-	586	495	106	71	232	262	25	312	303	326	240	376	177	63	163	3"	33	434	165	ø42	ø17	12	45	72.9	76.7	153	7.0
DW5/256/-	636	520	106	71	232	262	25	312	303	326	240	376	177	63	163	(DN125)	33	434	165	ø42	ø17	12	45	123.0	127.0	172	7.0
DW6/172/-	804	692	98	90	351	420	40	500	376	491	293	541	208	85	245	3"	49	528	218	ø50	ø24	14	54	72.9	76.7	370	25.0
DW6/198/-	804	692	98	90	351	420	40	500	376	491	293	541	208	85	245	3"	49	528	218	ø50	ø24	14	54	72.9	76.7	370	25.0
DW6/308/-	830	706	98	90	351	420	40	500	376	491	293	541	208	85	245	4"	49	528	218	ø50	ø24	14	54	97.6	102.5	390	25.0
DW6/519/-	881	732	98	90	351	420	40	500	376	491	293	541	208	85	245	DN150	49	528	215	ø50	ø24	14	54	150	157	460	25.0
DW7/370/-	1017	884	151	150	461	500	50	600	449	584	349	644	250	100	292	4"	59	627	258	ø65	ø24	18	69	97.6	102.5	590	40.0
DW7/420/-	1017	884	151	150	461	500	50	600	449	584	349	644	250	100	292	4"	59	627	258	ø65	ø24	18	69	97.6	102.5	590	40.0
DW7/725/-	1069	913	151	150	461	500	50	600	449	584	349	644	250	100	292	DN150	59	627	258	ø65	ø24	18	69	150	157	700	40.0
DW7/1016/-	1119	937	151	150	461	500	50	600	449	584	349	644	250	100	292	DN200	59	627	254.5	ø65	ø24	18	69	200	215	750	40.0

NOTE: Se næste side: Pumpens mål med fittings
See next page: Pump dimensions with fittings

7. Pumpens mål med fittings / Pump dimensions with fittings

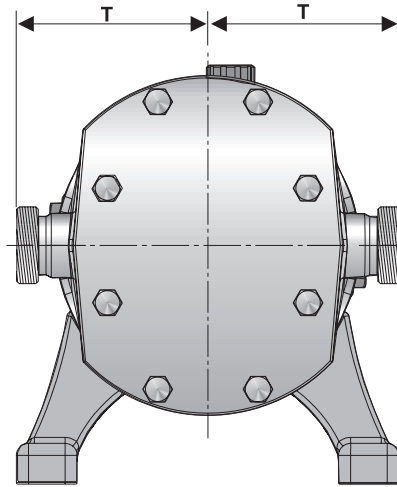

Pumpe	T								
	CLAMP			NIPLER / MALE PARTS					
	BS 4825 part 3	ISO 2852	DIN 32676	ISO 2853	BS 4825 part 4	SMS ("1145")	BS 4825 part 5	DIN 11851	DS 722
	1" TRI	1" ISO	DN25	1" ISO	1" IDF	1" SMS	1" RJT	DN25	1" DS
DW1/003/-	107.5	107.5	107.5	107.5	107.5	101	112.3	115	106
DW1/004/-	107.5	107.5	107.5	107.5	107.5	101	112.3	115	106
DW1/007/-	107.5	107.5	107.5	107.5	107.5	101	112.3	115	104.5
DW2/006/-	119.5	119.5	119.5	119.5	119.5	113	124.3	127	116.5
DW2/007/-	119.5	119.5	119.5	119.5	119.5	113	124.3	127	116.5
	1½" TRI	1½" ISO	DN40	1½" ISO	1½" IDF	1½" SMS	1½" RJT	DN40	1½" DS
DW2/013/-	119.5	119.5	119.5	119.5	119.5	118	124.3	131	126
DW3/014/-	133.5	133.5	133.5	133.5	133.5	132	138.3	145	130
DW3/017/-	133.5	133.5	133.5	133.5	133.5	132	138.3	145	130
	2" TRI	2" ISO	DN50	2" ISO	2" IDF	2" SMS	2" RJT	DN50	2" DS
DW3/030/-	133.5	133.5	133.5	133.5	133.5	132	138.3	147	132
DW3/050/-	133.5	133.5	133.5	133.5	133.5	132	138.3	147	132
DW4/033/-	151.5	151.5	151.5	151.5	151.5	150	156.3	165	150
DW4/039/-	151.5	151.5	151.5	151.5	151.5	150	156.3	165	150
	2½" TRI	2½" ISO	DN65	2½" ISO	2½" IDF	2½" SMS	2½" RJT	DN65	2½" DS
DW5/080/-	186.5	186.5	193	186.5	186.5	190	191.3	205	189
DW5/093/-	186.5	186.5	193	186.5	186.5	190	191.3	205	189
	3" TRI	3" ISO	DN80	3" ISO	3" IDF	3" SMS	3" RJT	DN80	3" DS
DW4/073/-	151.5	151.5	158	151.5	151.5	155	156.3	175	154
DW4/125/-	151.5	151.5	158	151.5	151.5	155	156.3	175	154
DW5/142/-	186.5	186.5	193	186.5	186.5	190	191.3	210	189
DW6/172/-	239.5	239.5	246	239.5	239.5	243	244.3	263	242
DW6/198/-	239.5	239.5	246	239.5	239.5	243	244.3	263	242
	4" TRI	4" ISO	DN100	4" ISO	4" IDF	4" SMS	4" RJT	DN100	4" DS
DW6/308/-	239.5	239.5	246	239.5	248	253	244.3	272	242
DW7/370/-	279.5	279.5	286	279.5	288	293	284.3	312	282
DW7/420/-	279.5	279.5	286	279.5	288	293	284.3	312	282
	5½" TRI	5½" ISO						DN125	
DW5/256/-	193	193						211	
	DN150 TRI	DN150 ISO	DN150				DN150 RJT	DN150	
DW6/519/-	243	243	243				255	265	
DW7/725/-	286	286	286				298	308	
	8 5/8" TRI	8 5/8" ISO							
DW7/1016/-	282.5	282.5							

7. Montagesæt for pumpe gennemskyl / Fittingtools for pump flushing

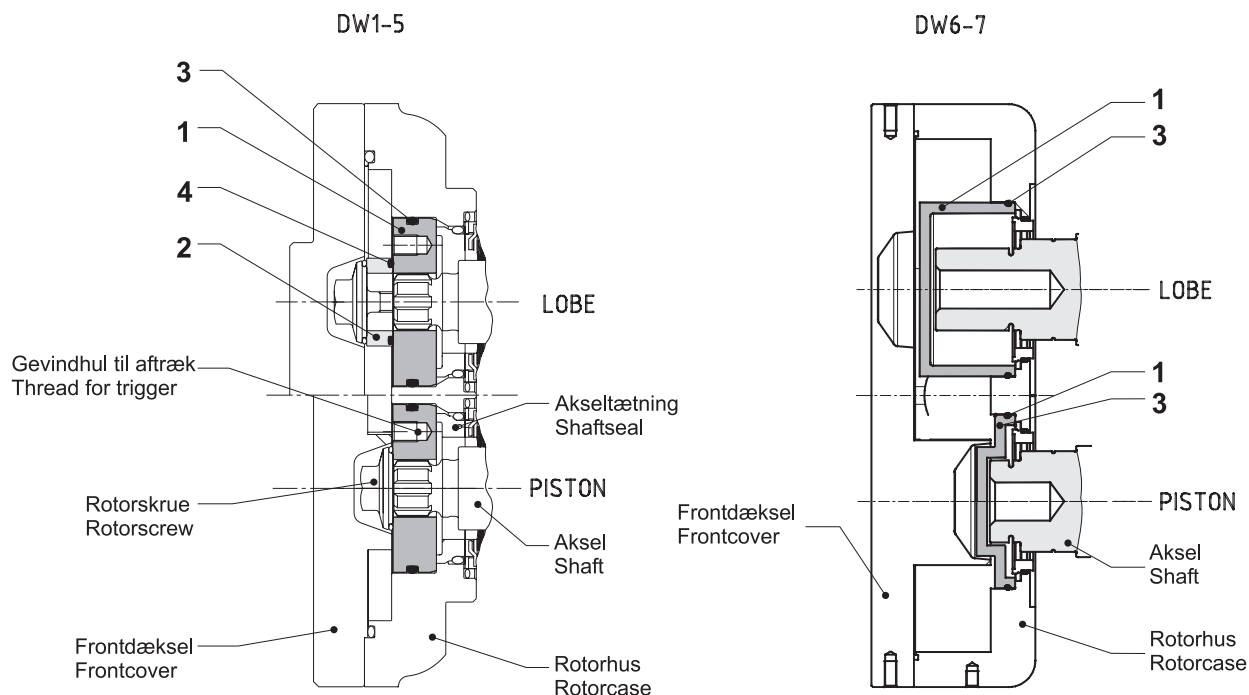

						Del nr. / Part No.					
						Piston	Lobe	Lobe	Piston	Lobe	Lobe
Pos	Stk/Qty	Material	Benævnelse	Description		DW1/003/-	DW1/004/-	DW1/007/-	DW2/006/-	DW2/007/-	DW2/013/-
1-4	-	-	Komplet kit	Complete kit		LA2370100	LA2370101	LA2370103	LA2370200	LA2370201	LA2370203
1	2	Plastic	Prop	Plug		L2200100	LA2200100	LA2200100	LA2200200	LA2200200	LA2200200
2	2	Plastic	Afstandsstykke	Spacer			LA1852100	LA1852101		LA1852200	LA1852201
3	2	EPDM	O-ring	O-ring		L25060204	L25060204	L25060204	L25042004	L25042004	L25042004
4	2	EPDM	O-ring	O-ring			L2511004	L2511004		L2511004	2511004
						DW3/014/-	DW3/017/-	DW3/030/-	DW4/033/-	DW4/039/-	DW4/073/-
1-4	-	-	Komplet kit	Complete kit		LA2370300	LA2370301	LA2370303	LA2370400	LA2370401	LA2370403
1	2	Plastic	Prop	Plug		LA2200300	LA2200300	LA2200300	LA2200400	LA2200400	LA2200400
2	2	Plastic	Afstandsstykke	Spacer			LA1852300	LA1852301		LA1852400	LA1852401
3	2	EPDM	O-ring	O-ring		L25061004	L25061004	L25061004	L25045004	L25045004	L25045004
4	2	EPDM	O-ring	O-ring			L25029004	L25029004		L25029004	L25029004

						Lobe	Lobe	Piston	Lobe	Lobe	Lobe
Pos	Stk/Qty	Material	Benævnelse	Description		DW3/050/-	DW4/125/-	DW5/080/-	DW5/093/-	DW5/142/-	DW5/256/-
1-4	-	-	Komplet kit	Complete kit		LA2370313	LA2370413	LA2370500	LA2370501	LA2370505	LA2370503
1	2	Plastic	Prop	Plug		LA2200300	LA2200400	LA2200500	LA2200500	LA2200500	LA2200500
2	2	Plastic	Afstandsstykke	Spacer		LA1852302	LA1852402		LA1852500	LA1852501	LA1852502
3	2	EPDM	O-ring	O-ring		L25061004	L25045004	L25062004	L25062004	L25062004	L25062004
4	2	EPDM	O-ring	O-ring		L25029004	L25029004		L25034004	L25034004	L25034004

						Piston	Lobe	Lobe	Lobe
Pos	Stk/Qty	Material	Benævnelse	Description		DW6/172/-	DW6/198/-	DW6/308/-	DW6/519/-
1-4	-	-	Komplet kit	Complete kit		LA2370600	LA2370601	LA2370601	LA2370601
1	2	Plastic	Prop	Plug		LA1857601	LA1857600	LA1857600	LA1857600
3	2	EPDM	O-ring	O-ring		L2580004	L25069004	L25069004	L25069004
						DW7/370/-	DW7/420/-	DW7/725/-	DW7/1016/-
1-4	-	-	Komplet kit	Complete kit		LA2370700	LA2370701	LA2370701	LA2370701
1	2	Plastic	Prop	Plug		LA1857701	LA1857700	LA1857700	LA1857700
3	2	Nitril/ FPM (Viton)	O-ring	O-ring		L771577	L25030002	L25030002	L25030002

7. Låseværktøj / Locking tool

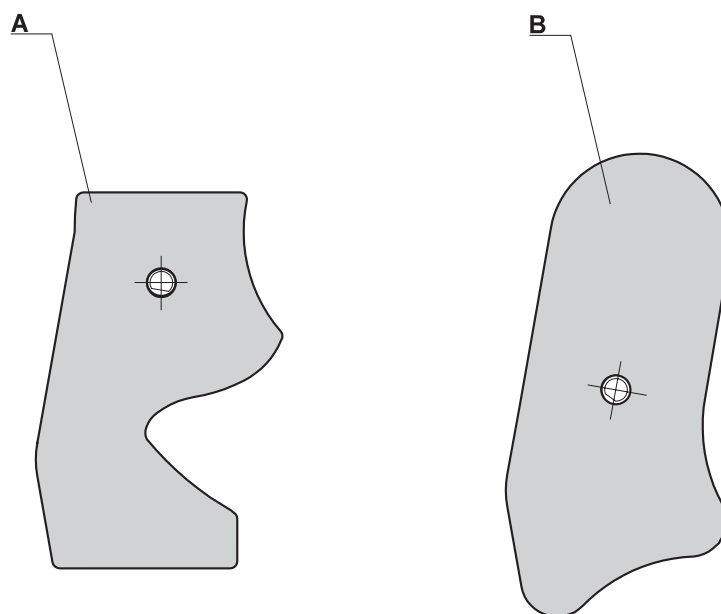

Qty.	Material	Benævnelse	Description	Pumpe type / Pump type				
				DW1	DW2	DW3	DW4	DW5, DW6 og DW7
1	Plastic	Drejestempel låse værktøj (A)	Piston locking tool (A)	LAFT0001	LAFT0002	LAFT0003	LAFT0004	LAFT0005
1	Plastic	Lobe låse værktøj (B)	Lobe locking tool (B)	LAFT0011	LAFT0012	LAFT0013	LAFT0014	LAFT0015

7. Aftrækker værktøj / Removal tool

DW1-7

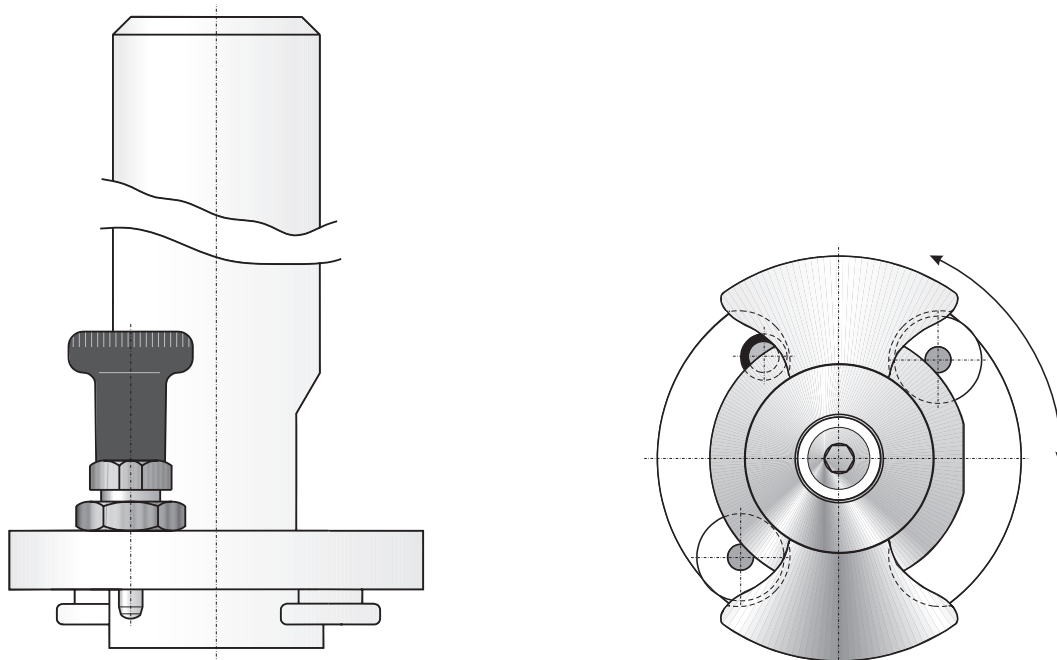

Pos.	Qty.	Benævnelse	Description	Pumpe type / Pump type						
				DW1	DW2	DW3	DW4	DW5	DW6	DW7
-	1	Piston aftrækker	Piston removal	LAFT0041	LAFT0042	LAFT0043	LAFT0044	LAFT0045	#	#

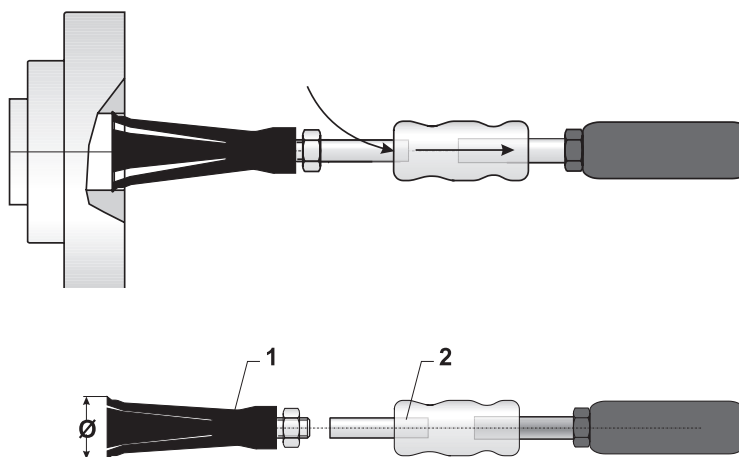

Pos.	Qty.	Benævnelse	Description	Pumpe type / Pump type						
				DW1	DW2	DW3	DW4	DW5	DW6	DW7
1	1	Lobe aftrækker	Lobe removal	Ø 17	Ø 22.5	Ø 27.5	Ø 37	Ø 48		
2	1	Slagaftrækker	Impact hammer	L773507	L773507	L773507	L773507	L773507	#	#

Kontakt APV for aftrækkerværktøj til DW6 og DW7 / Contact APV for DW6 and DW7 removal tool

DW Pump

ROTARY LOBE PUMPS



SPX FLOW TECHNOLOGY POLAND sp. z o.o.

Hermana Frankego 9
85-862 Bydgoszcz, Poland
Phone: +48 52 525 9900
Fax: +48 52 525 9909

SPX reserves the right to incorporate our latest design and material changes without notice or obligation.

Design features, materials of construction and dimensional data, as described in this bulletin, are provided for your information only and should not be relied upon unless confirmed in writing. Please contact your local sales representative for product availability in your region. For more information visit www.spx.com

ISSUED 12/2012 - Original Manual
Copyright © 2012 SPX Corporation