

APV DELTA MS4

DIAPHRAGM VALVE WITH "FAN SUPPORT"

FORM NO.: H323278 REVISION: UK-3

READ AND UNDERSTAND THIS MANUAL PRIOR TO OPERATING OR SERVICING THIS PRODUCT.



Scan for MS4 Valve
Maintenance Video



We,

DESIGN CENTER/MANUFACTURER: SPX Flow Technology Germany GmbH
Gottlieb-Daimler-Str. 13, D-59439 Holzwickede

MANUFACTURING FACILITY: SPX Flow Technology Poland sp. z o.o.
Rolbieskiego 2, 85-862 Bydgoszcz, Poland

AUTHORIZED REPRESENTATIVE: SPX Flow Europe Ltd.
(for UKCA) Building A, Compass House, Manor Royal
Crawley, RH10 9PY

declare under our sole responsibility that the

APV double seal and double seat valves of the series
SD4, SDT4, SDU4, SDMS4, SDMSU4, SDTMS4, SWcip4, DSV, DA4, DA4 DPF, D4 SL, DU4
SL, DT4 SL, DP4 SL, D4, DA3, DA3SLD, DE3, DEU3, DET3, DKR2, DKRT2, DKRH2

APV butterfly valves of the series SV1, SVS1F, SV2, SVS2F, SVL, SVSL, SVE, SVSE

APV ball valves of the series BLV1

APV single seat, diaphragm and spring loaded valves of the series
S2, SW4, SWhp4, SW4DPF, SWmini4, SWT4, SWS4, MF4, MS4, MSP4, AP/T1, CPV, RG4,
RG4DPF, RGMS4, RGE4, RGE4DPF, RGEMS4, PR2, PRD2, SI2, UF/R3, UF/R4, VRA/H

and the valve manifolds installed thereof

meet the requirements of the Machinery Directive 2006/42/EC
& EN ISO 12100-2010, DIN EN ISO 14159-2008-07, DIN EN 1672-2-2009-07.

Holzwickede, November 2022



Dr.-Ing. Behdad Ariatabar, Design Center Lead - Valves

meet the requirements of the Supply of Machinery (Safety) Regulations 2008 No. 1597
& BS harmonized standards.

Crawley, November 2022

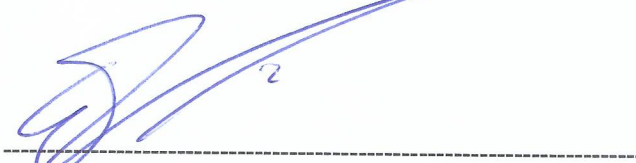

Ewout Roozendaal, Director Global Pricing

Contents	Page
1. General Terms	2
2. Safety Instructions	2-3
3. Intended Use	3
4. Mode of Operation	4
5. Auxiliary Equipment	5–6
5.1. Valve position indication (proximity switches)	
5.2. Control Unit	
5.3. Tank bottom welding flange (option)	
5.4. Connections	
6. Cleaning	7
7. Installation	8
7.1. Welding Instructions	
8. Dimensions / Weights	9–11
8.1. Single seat diaphragm valve	
8.2. Change-over diaphragm valve	
8.3. Tank outlet valve	
9. Technical Data	12–14
9.1. General terms	
9.2. Specification of compressed air	
9.3. Opening and closing times	
9.4. Pneumatic air consumption	
9.5. Kvs values in m ³ /h	
9.6. Valve stroke / Opening cross section	
10. Maintenance	14–15
10.1. Assembly tool	
11. Service Instructions	16-18
11.1. Dismantling from line system	
11.2. Dismantling of wear parts (product-wetted parts)	
11.3. Installation of seals and assembly of valve	
11.4. Installation of MS4 valve	
12. Service Instructions - Actuator	19
12.1. Maintenance of actuator	
12.2. Dismantling of seals	
12.3. Installation of seals and assembly of actuator	
12.4. Reconstruction of valve design from normally closed (NC) to normally open (NO) design	
13. Service Instructions - Assembly Tool	20
13.1. Installation of seat seal in valve shaft	
13.2. Installation of seat seal for change-over valve	
14. Service Instructions - Change-over diaphragm valve	21–23
14.1. Dismantling from line system	
14.2. Installation of seals and assembly of valve	
15. Trouble Shooting	24
16. Spare Parts Lists	24
MS4, MSE4 and MST4 - DN design	RN 01.064.9
MS4, MSE4 and MST4 - Inch design	RN 01.064.9-1
MSP4, MSEP4 and MSTP4 - DN design	RN 01.064.10
MSP4, MSEP4 and MSTP4 - Inch design	RN 01.064.10-1
MSES4 - DN design	RN 01.064.12
MSES4 - Inch design	RN 01.064.12-1
MSR4 - DN design	RN 01.064.xx
MSR4 - Inch design	RN 01.064.xx-1
Actuator SW4	RN 01.054.86
MS4 and MSE4 - Inch design	RN 01.064.9-2

1. General Terms

This instruction manual should be read carefully by the competent operating and maintenance personnel.

We point out that we will not accept any liability for damage or malfunctions resulting from the non-compliance with this instruction manual.

Descriptions and data given herein are subject to technical changes..

2. Safety Instructions

The valve must be assembled, operated, dismantled, maintained and serviced only by competent, trained personnel.
Please contact your local SPX FLOW site if necessary.



Danger!

- The technical safety symbol draws your attention to important directions for operating safety. You will find it wherever the activities described are bearing health hazards or risks for persons or material assets.



Do not reach into the open valve or yoke!

Risk of injury by suddenly operating valve. In dismantled state there is the risk of bruising at movable parts of the valve.



Attention!

Valve design NC (normally closed): Control the actuator with air before releasing the housing screws.

- Before any maintenance work, the line and cleaning system must be depressurized and discharged if possible.
- If the diaphragm is damaged, leakges will emerge from the leakage bore in the yoke area.
- Electric and pneumatic connections must be separated.
- Observe service instructions to ensure safe maintenance of the valve.
- Schedule regular valve maintenance including the replacement of all seals in order to prevent leakages of any type.

2. Safety Instructions



Attention! Welded actuators are preloaded by spring force.

**Opening of the actuators is strictly forbidden.
Danger to life!**

Actuators which are no longer used and / or defective must be disposed in professional manner.

Defective actuators must be returned to your SPX FLOW company for their professional disposal and free of charge for you.

Contact your local SPX FLOW company.

3. Intended Use

The intended use as field of application of the diaphragm valve is the shut-off of pipeline sections.

Unauthorized, structural changes at the valve will affect safety and the intended functionality of the valves and are **not** permissible.

Authorizations and External Approvals

To view the certifications for this and other innovative SPX FLOW products, visit

<https://www.spxflow.com/en/apv/about-us/certifications/>

4. Mode of Operation

DELTA MS4

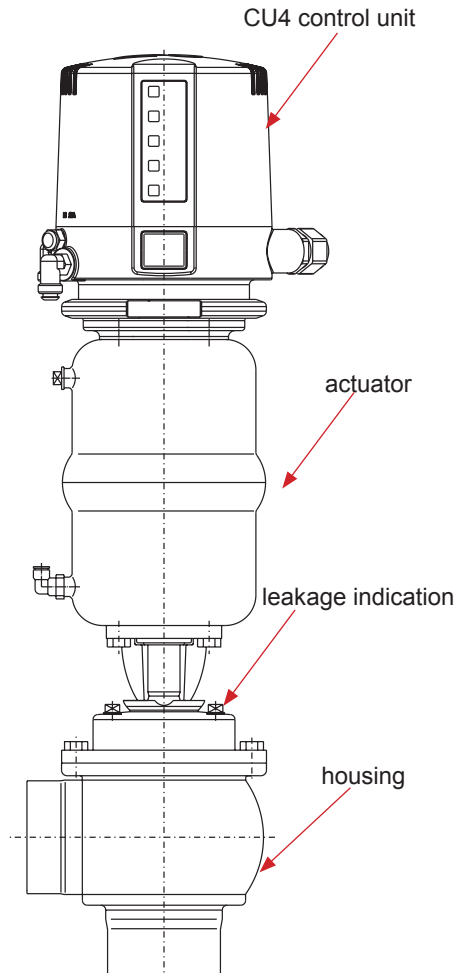

4.1. General terms

DELTA MS4 diaphragm valves have been designed for use in the brewing and beverage industries, in the dairy and food industries as well as for chemical and pharmaceutical applications.

The field of application of the DELTA MS4 valve comprises the safe shut-off of pipeline sections.

Diaphragm valves offer optimum product protection in hygienic and aseptic applications. Product safety is provided by the hermetic separation of the product chamber to the exterior (atmosphere) by means of a diaphragm with fan support.

The standard MS4 valve series is equipped with a valve position indication.

As an option, a control unit can be installed on the actuator.

- Operation by pneumatic actuator with air connection, reset by spring force. The actuator is generally mounted in normally closed (**NC**) manner.
- Through different assembly of the actuator, the following designs are possible:
NC: actuator normally closed (NC); air-to-raise, spring-to-lower
NO: actuator normally open (NO); air-to-lower, spring-to-raise
- The inner parts of the actuator are maintenance-free.
- In order to prevent pressure hammers, the valve should be closed against the flow direction of the medium.
- Leakages at the diaphragm are indicated in the yoke area through a leakage drain.
- Different valve designs are available:
 Single seat valves: DELTA MS4
 DELTA MSP4
 (with diaphragm shaft made of PTFE)
 DELTA MSR4
 (with regulating cone)
- Tank outlet valves: DELTA MST4
 DELTA MSTP4
 (with diaphragm shaft made of PTFE)
- Change-over valves: DELTA MSES4

5. Auxiliary Equipment

fig. 5.1.

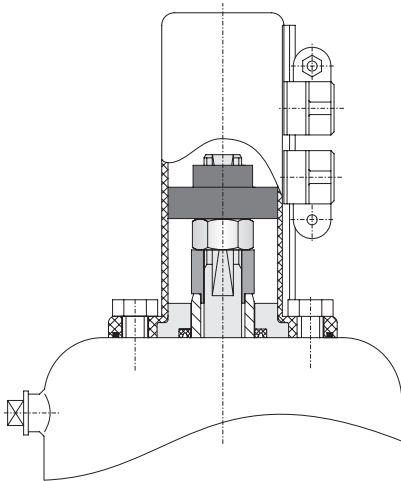

5.1. Valve position indication (fig. 5.1.)

For the valve position indication a proximity switch support can be installed direct at the actuator.

Proximity switches to signal the limit position of the valve seat can be installed at the proximity switch holder (PSH) if required.

We recommend to use one of our APV standard types:

operating distance : 5mm / diameter: 11mm.

Operating voltage: 10 - 30 VDC

Output: operating current pnp - positive switching

Connection: moulded cable 5 m long

Protective type: IP 67

Reference number: 08 - 60 - 011/93; H16223

If the customer decides to use a valve position indicator other than APV type, we cannot take over any liability for any malfunctions.

5.2. Control Unit (fig. 5.2.)

The installation of a control unit on the MS4 valve is possible.

The following different designs are available:

fig. 5.2.

CU3 control unit



CU4 control unit



Direct Connect reference number; ID-No.	CU41-S-Direct Connect 08-45-100/93; H320460
Profibus reference number; ID-No.	CU31-Profibus 08 - 45 - 001/93; H315495
Device Net reference number; ID-No.	CU31-Device Net 16 - 31 - 240/93; H209422
AS-interface extended reference number; ID-No.	CU41-S-AS-i extended 08 - 45 - 110/93; H320467

For the installation of the control unit on the MS4 valve an adapter is required:

Designation: reference number:	CU3 adapter SW4 / M4 08-48-480/93; H315806
Designation: reference number:	CU4-S adapter for DN25/1"-100/4" 08-48-600/93; H320474

5. Auxiliary Equipment

5.3. Tank bottom welding flange for the valve series MST4 and MSTP4

The tank bottom welded flange does not form part of the scope of supply of a valve and can be ordered with the following reference / ID number:

tank bottom welding flange
(option)

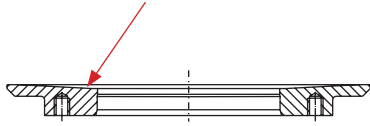

DELTA MST4

housing seal

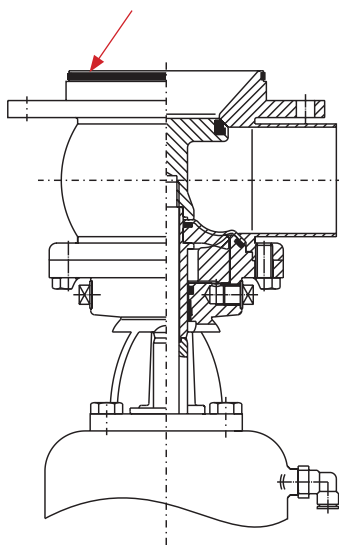

DN	Inch	Ø C	D	Ø E	F	Reference number
25	1"	148	2	66	M8	31B 15-01-391/42 H157269
40	1,5"	168	2	78	M8	31B 15-01-441/42 H157270
50	2"	188	2	94	M8	31B 15-01-491/42 H157260
65	2,5", 3"	228	2	109	M10	31B 15-01-541/42 H156931
80	–	258	2	128	M10	31B 15-01-641/42 H157271
100	4"	288	2	159	M10	31B 15-01-691/42 H157272

tank bottom welding flange
(option)

Dimensions in mm

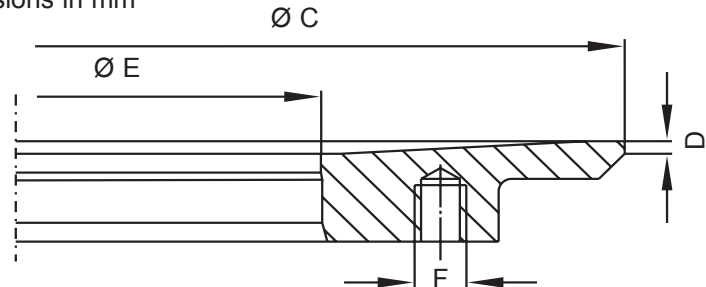

5.4. Connections

Beside the housings with weld ends, the following connections are alternatively available:

- threaded connection according to DIN 11851
- threaded connection IDF / ISS according to ISO 2853
- threaded connection RJT according to BS 4825-5
- threaded connection SMS
- threaded connection according to DS 722
- flange connection FGN1 DIN
- flange connection FGN1 Inch
- clamp connection according to DIN 32676
- clamp connection according to ISO 2852

6. Cleaning

6.1. Cleaning recommendation

Flow areas

The passages of the valve are cleaned by the cleaning liquid during cleaning of the connected pipelines.

Depending on the degree and constituents of soiling, the cleaning liquids, times and processes must be scheduled for the individual application.

The compatibility of the individually selected cleaning processes and liquids with the respectively used seals must be verified.

Under normal conditions, 15 valves DN 25/1" - 100/4" can be cleaned via one spray distribution line DN 25.

7. Installation

Installation has to be undertaken in such a way that fluids can drain off the valve housing and should preferably be done in vertical position.

- The valve housing can be welded direct into the pipeline (completely dismantable valve insert).

Attention! Observe welding instructions.

7.1. Welding Instructions

MS4

- Before welding of the valve, the valve insert must be dismantled from the housing. Careful handling to avoid damage to the parts is necessary.
- Welding should only be carried out by certified welders (DIN EN ISO9606-1). (seam quality DIN EN ISO 5817)
- The welding of the valve housings must be undertaken in such a way that the valve body is not deformed.
- The preparation of the weld seam up to 3 mm thickness must be carried out in butt manner as a square butt joint without air. (Consider shrinkage!)
- TIG orbital welding is best.
- After welding of the valve housing or of the mating flanges and after work at the pipelines, the corresponding parts of the installation or pipeline must be cleaned from welding residues and soiling. If these cleaning instructions are not observed, welding residues and dirt particles can settle in the valve and cause damage.
- Any damage resulting from the non-observance of these welding instructions is not subject to our guarantee.
- Welding directives for aseptic application areas of the AWS/ANSI regulations and EHEDG guidelines must be observed.

8. Dimensions / Weights

8.1. Single seat diaphragm valve

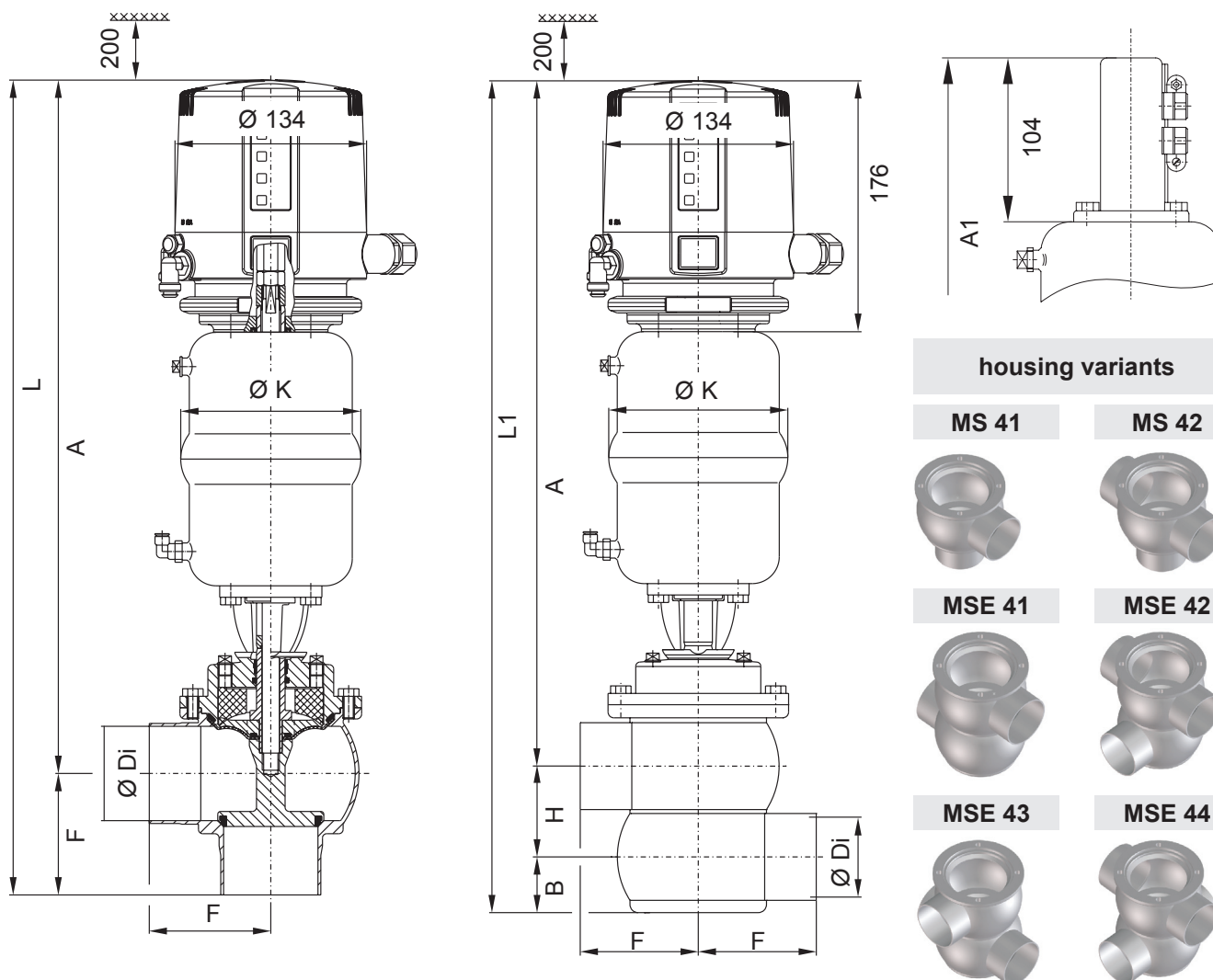

Dimensions in mm										Weight in kg
DN	A	A1	B	Ø Di	F	H	Ø K	L	L1	
25	419	347	19	26	50	32	86	469	470	4,2
40	466,5	394,5	28	38	67	44	126	533,5	538,5	7,1
50	472,5	400,5	34	50	72	56	126	544,5	562,5	7,1
65	529	457	42	66	85	74	189	614	645	7,9
80	538	466	49,5	81	98	91	189	636	678,5	14,2
100	555	483	59	100	111	110	189	666	724	15,2
Inch										
1"	417	345	17,3	22,2	50	28,6	86	467	463	4,2
1,5"	465	393	26,5	34,9	67	41,1	126	532	532,6	7,1
2"	471	399	32,9	47,6	72	53,8	126	543	557,7	7,1
2,5"	526	454	39,1	60,3	85	68,3	189	611	633,4	7,9
3"	532	460	45,0	72,9	90	80,1	189	632	657,1	14,5
4"	554	482	57,8	97,6	111	107,6	189	665	719,4	15,2

8. Dimensions / Weights

8.2. Change-over diaphragm valves MSES4

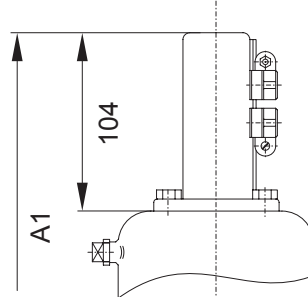
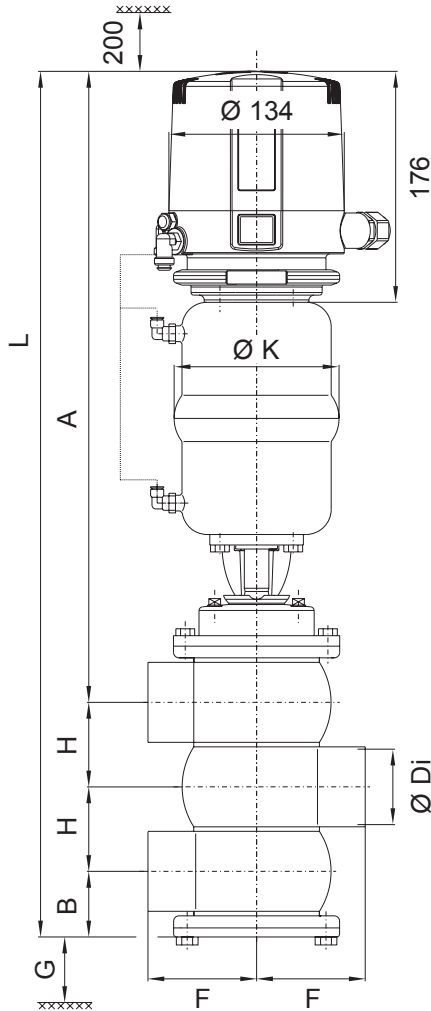

housing variants

MES45

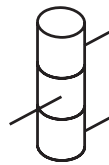

MES46

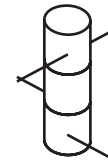

MES47

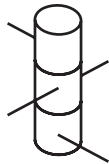

MES48

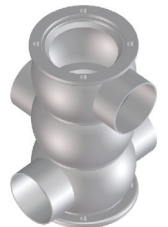
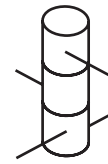

Dimensions in mm										Weight in kg
DN	A	A1	B	Ø Di	F	H	Ø K	L	G	
25	419	347	29,5	26	50	32	86	512,5	290	8,0
40	466,5	394,5	37,5	38	67	44	126	592	300	11,8
50	472,5	400,5	45,5	50	72	56	126	630	310	12,8
65	529	457	52,0	66	85	74	189	729	330	14,5
80	538	466	59,5	81	98	91	189	779,5	380	21,8
100	554	483	69,0	100	111	110	189	843	400	27,7
Inch										
1"	417	345	28	22,2	50	28,6	86	502,2	290	8,0
1,5"	465	393	37	34,9	67	41,1	126	584,2	300	11,8
2"	471	399	43	47,6	72	53,8	126	621,6	310	12,8
2,5"	526	454	49	60,3	85	68,3	189	711,6	330	14,5
3"	532	460	55	72,9	100	80,1	189	747,2	380	21,8
4"	554	482	68	97,6	111	107,6	189	837,2	400	27,7

8. Dimensions / Weights

8.3. Tank outlet valve MST4

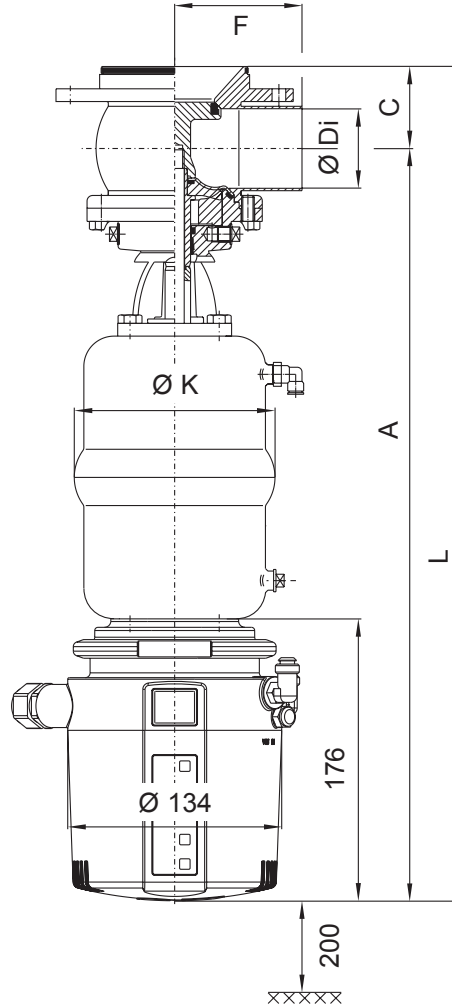

housing variants

MST41

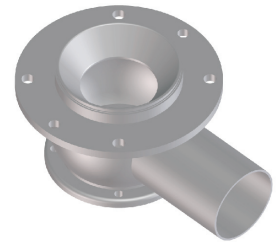

MST42

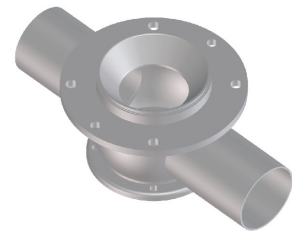

Dimensions in mm							Weight in kg
DN	A	C	Ø Di	F	Ø K	L	
25	419	38,0	26	100	86	457	8,0
40	466,5	43,5	38	120	126	510	11,8
50	472,5	51,5	50	120	126	524	12,8
65	529	62,0	66	150	189	591	14,5
80	538	69,5	81	150	189	608	21,8
100	554	83,0	100	150	189	638	27,7
Inch							
1"	417	36,3	22,2	100	86	454	8,0
1,5"	465	42,1	34,9	120	126	507	11,8
2"	471	50,4	47,6	120	126	522	12,8
2,5"	526	59	60,3	150	189	585	14,5
3"	532	65,1	72,9	150	189	597	21,8
4"	554	81,8	97,6	150	189	636	27,7

9. Technical Data

9.1. General

Product-wetted parts:	1.4404 (DIN EN 10088)
Other parts:	1.4301 (DIN EN 10088)
Seals: standard design	EPDM
Option:	HNBR, VMQ, FPM
Diaphragm:	PTFE (TFM 1705)
Actuator:	1.4301 (DIN EN 10088)
max. line pressure:	10 bar
max. operating temperature:	135 °C EPDM, HNBR *FPM, *VMQ
short-term load:	140 °C EPDM, HNBR *FPM, *VMQ *(no steam)

Air connection (for hose):	6 x 1 mm
max. pneumatic air pressure:	8 bar
min. pneumatic air pressure:	6 bar

Leakage indication in yoke area: G1/8"

9.2. Specification of compressed air quality

compressed air quality:	quality class acc. to DIN ISO 8573-1
content of solid particles:	<i>Quality Class 3</i> max. size of solid particles per m ³ 10000 of 0.5 µm < d < 1.0 µm 500 of 1.0 µm < d < 5.0 µm
content of water:	<i>Quality Class 3</i> max. dew point temperature -20 °C For installations at lower temperatures or at higher altitudes, additional measures must be considered to reduce the pressure dew point accordingly.
content of oil:	<i>Quality Class 1</i> max. 0.01 mg/m ³

The oil applied must be compatible with Polyurethane elastomer materials.

9. Technical Data

9.3. Closing times for single seat and change-over valves DELTA MS4

For valves equipped with a control unit DELTA CU, the opening and closing times can be increased by adjustment of the throttling screw at the solenoid valve.

		closing times in sec. pneumatic air pressure 6 bar	
		hose length in meter	
DN	Inch	1 m	10 m
25	1"	1	2
40	1,5"	3	4
50	2"	3	4
65	2,5"	5	6
80	3"	5	6
100	4"	5	6

9.4. DELTA MS4 – Pneumatic air consumption at 6 bar control pressure

Actuator	per stroke NL
∅ 74 mm	1,0
∅ 110 mm	2,1
∅ 165 mm	4,5

9.5. DELTA MS4 – kvs values in m³/h

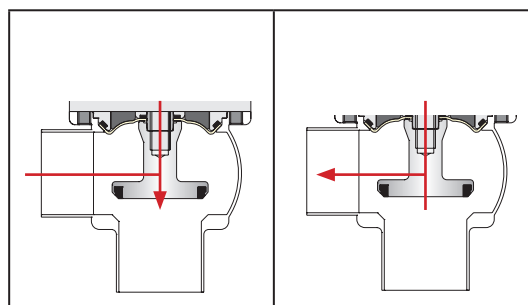

DN	Inch		
25	1"	22	22
40	1,5"	42	38
50	2"	73	70
65	2,5"	120	112
	3"	135	135
80		170	160
100	4"	325	276

9. Technical Data

9.6. Valve stroke / Opening cross section (X)

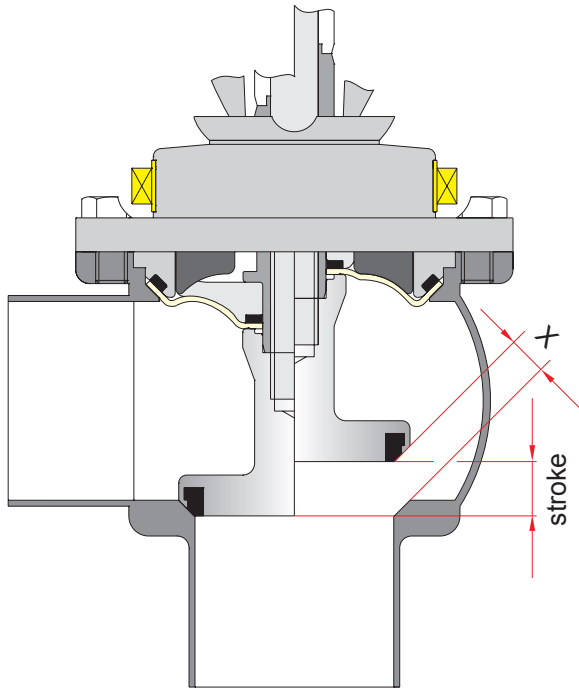

Dimensions in mm

DN	Stroke	X
25	8	5,5
40	13	10
50	13	10
65	16	13
80	22,5	19,5
100	28	25
Inch		
1"	8	5,5
1,5"	13	10
2"	13	10
2,5"	16	13
3"	17	14
4"	28	25

10. Maintenance

The maintenance intervals depend on the corresponding application and are to be determined by the user himself carrying out temporary checks.

- The valve must not be cleaned with products containing abrasive or polishing material. Especially the valve shaft must not, under any circumstances, be cleaned with such agents. Damage of the valve shaft can lead to leakages.
- Replacement of seals according to Service Instructions. Customer stock keeping of spare seals is recommended. For valve service we supply complete seal kits including seal grease (see spare parts lists).

10. Maintenance

Scan for MS4 Valve Maintenance Video



Required tools:

- 1x wrench SW13
- 1x wrench SW17
- 1x wrench SW19
- 1x wrench SW30
- 1x strap wrench
- cleaning rag as well as a low solution of a suitable cleaning agent (observe safety data sheet of cleaning liquid manufacturer).

- All seals must be provided with a thin layer of grease before their installation.



Recommendation:

APV assembly grease for EPDM, HNBR and FPM (Viton)
 (0,75 kg/ tin - ref.-No. 000 70-01-019/93; H147382)
 (60 g/ tube - ref.-No. 000 70-01-018/93; H147381)

APV assembly grease for VMQ (Silicone)
 (0,60kg/ tin - ref.-No. 000 70-01-017/93; H147380)
 (60 g/ tube - ref.-No. 000 70-01-016/93; H147379)

! Do not use grease containing mineral oil for EPDM seals.
 ! Do not use grease on Silicone oil basis for VMQ seals.

! No matter what type of application, use only those greases being suited for the respective seal material !

Recommendation for screw retention:

Type: Loctite 243 semi-solid
 (50ml - ref.-No. 00070-01-111/93; H206336)

10.1. Assembly tool

To simplify the installation of the seat seal, the following assembly tools are available.

Assembly tool M4		
DN	Inch	ref.-No.; ID-No.
25	1"	000 51-13-110/17 ; H179465
40	1,5"	000 51-13-111/17 ; H179466
50	2"	000 51-13-112/17 ; H179467
65	2,5"	000 51-13-113/17 ; H179469
	3"	000 51-13-121/17 ; H179470
80		000 51-13-114/17 ; H179471
100	4"	000 51-13-115/17 ; H179472

11. Service Instructions

11.1. Dismantling from the line system - MS4

The reference numbers refer to the spare parts drawings

MS4: DIN design RN 01.064.9
 Inch design RN 01.064.9-1
 3A- Inch design RN 01.064.9-2

1. Shut off the line pressure and discharge lines if possible.

2. **NC version:** **Control actuator with air.**



Do not touch movable parts!
Risk of injury.

3. Remove the hex. screws (14) and lift the complete valve insert with actuator out of the housing

4. **NC version:** **Shut off compressed air and remove compressed air connection.**

5. **Design with Control Unit:**

Remove the control unit.

Design with valve position indicator:

Remove the proximity switches. Detach the indicator housing (**proximity switch support**) from the actuator.

11.2. Dismantling of wear parts (product-wetted parts)

1. **Design with control unit and valve position indication:**

At first, unscrew the actuator screw. Release the hex. nut (22), while holding up the centering washer (21). Remove the centering washer.

2. Extract the shaft with guide rod (3), diaphragm (5), fan (6), upper shaft (4) and diaphragm support (7) from the actuator (17). Remove the seat seal (2) and o-ring (16).

3. Remove the yoke (9) from the actuator (17).

The actuator can be maintained.

(see 12. Service Instructions - Actuator).

4. Detach the o-rings (15, 13) and guide bush (11) from the yoke (9).

5. Clean the valve housing, yoke, actuator and shaft with a low solution of a cleaning agent. Never use cleaning agents containing abrasive or polishing material.

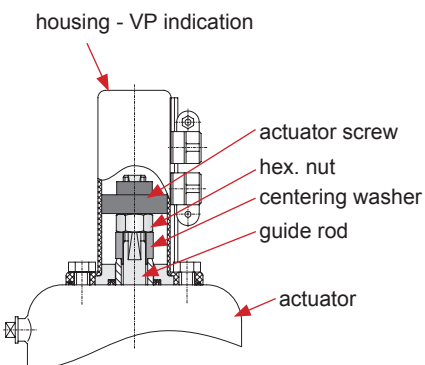
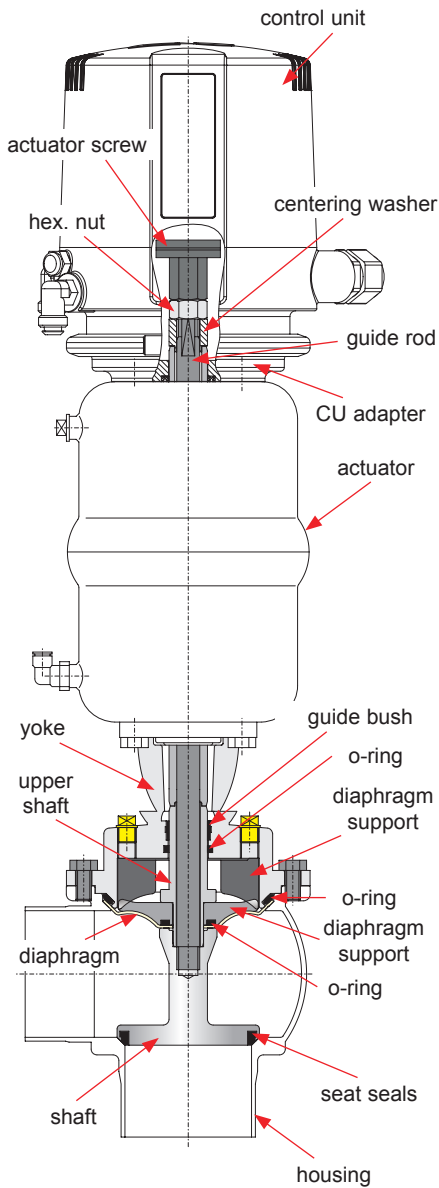

11. Service Instructions

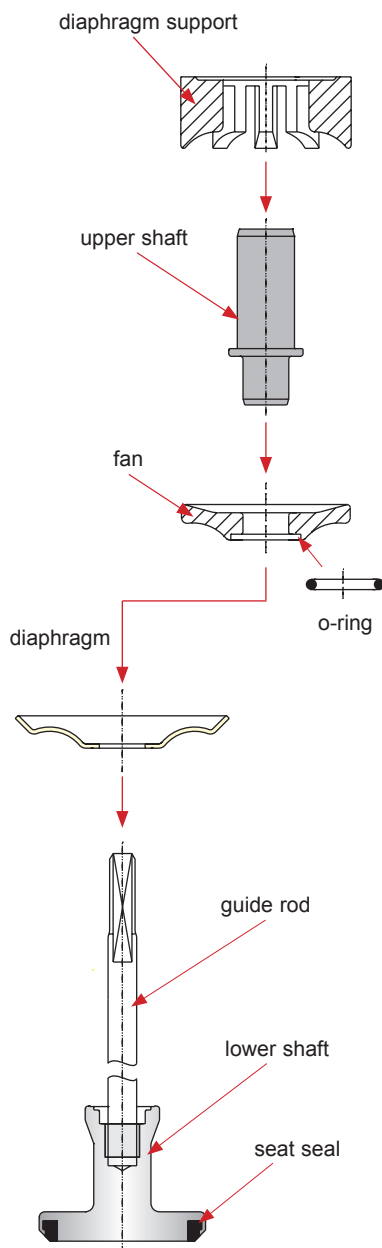
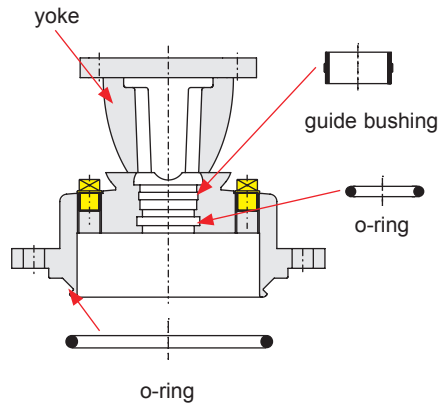

11.3. Installation of seals and assembly of valve

All seals must be provided with a thin layer of grease before their installation.

1. Insert the guide bush (11) and o-ring (13) in the yoke (9). Insert the o-ring (15) in the groove of the yoke. Fasten the yoke (9) at the actuator (17).
2. Install the seat seal (2) in the lower valve shaft (3). (see Service Instructions 11.)
3. Install the o-ring (16) in the fan (6). Place diaphragm and fan on the upper shaft.
4. Wind the protective pipe over the thread of the guide rod.
5. Pass the guide rod through the upper shaft with diaphragm and fan until it stops on the lower shaft. Insert the diaphragm support into the fan.

! Toothing of fan and diaphragm support must interlock.

- Insert the pre-assembled lower shaft with guide rod, diaphragm, fan, upper shaft and diaphragm support through the yoke (9) and actuator (17).

The upper shaft must be guided through the guide bush into the yoke in smooth-running manner. In case of mechanical stiffness, check the right fit of the guide bush.

Design with control unit and valve position indication Place the centering washer (21). Apply a drop of a screw locker, e.g. type Loctite, semi-solid, on the thread of the guide rod. Screw on the hex. nut (22) and fasten it with a tightening torque of $M_d = 40 \text{ Nm}$. Hold up the centering washer during this process.

- ! Control Unit: Fasten the plastic actuator screw.
- ! Valve position indicator: Fasten the metallic actuator screw.

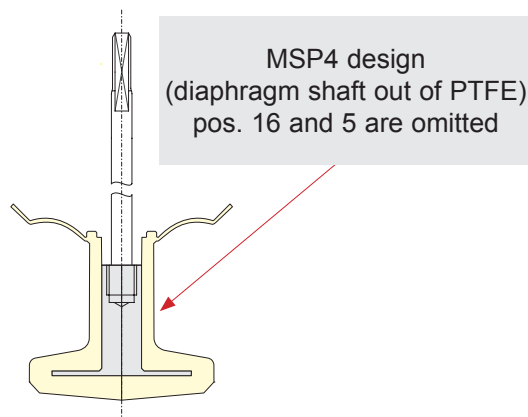

11. Service Instructions

11.4. Installation of MS4 valve

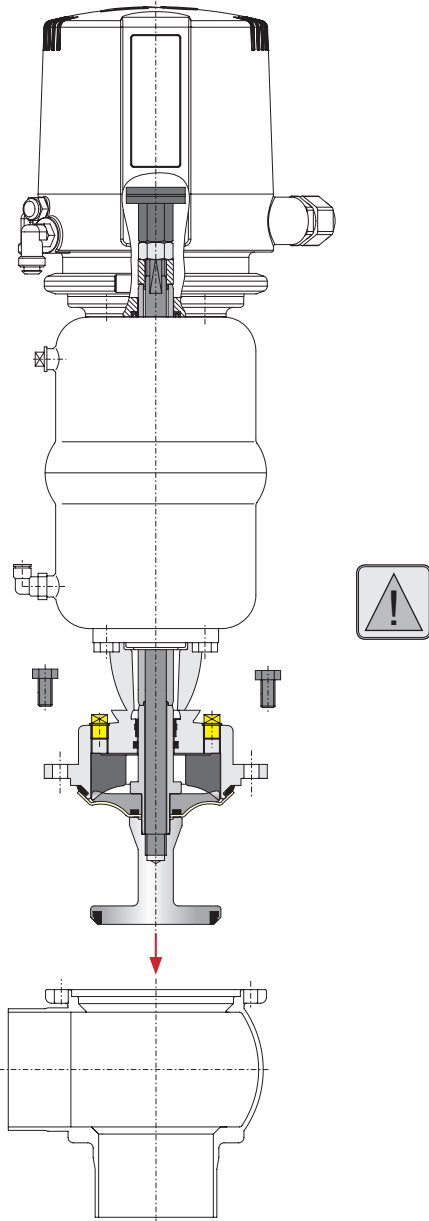

1. Design with control unit:

Fasten the adapter on the actuator.

Place the control unit (26) on the adapter (27) and fasten it with the ring.

Design with valve position indication:

Fasten the housing of the valve position indication (24).

2. Version NC: During the assembly of the valve insert observe the following:

- Control the actuator (version: NC) with pneumatic air min. 6 bar.
Carefully place the valve insert into the valve housing. The diaphragm (5) must not be damaged during the installation in the valve housing. Tighten the hex. screws (14) crosswise in the housing flange.

Do not reach for movable parts!
Risk of injury.

! Version NC: Shut off air supply.

3. Check the basic adjustment of the valve position indication.

- By turning the positioning screw in the control unit, the shift points can be adjusted.

4. Design with valve position indication:

Push in the proximity switches and fasten them.

Readjust the proximity switches if necessary.

5. Adjustment of proximity switches: (fig. 11.4)

- Drive the actuator into a limit position.
- Drive the corresponding proximity switch into the corresponding position. For this purpose release the positioning screw and move the holder until the corresponding signal is indicated. Then, continue to slide the holder by 2 to 3 mm in order to secure the indication. Fasten the positioning screw.
- Position the actuator in the other limit position and carry out the positioning of the second proximity switch.
- Upper valve position indication:
valve NO "normally open" (air-to-lower, spring-to-raise)
- Lower valve position indication:
valve NC "normally closed" (air-to-raise, spring-to-lower)

fig. 11.4

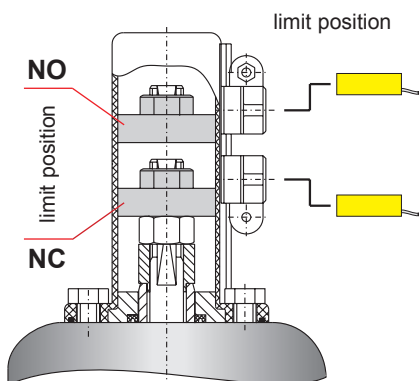

12. Service Instructions - Actuator

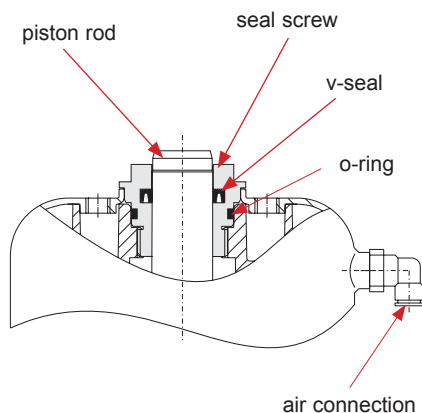
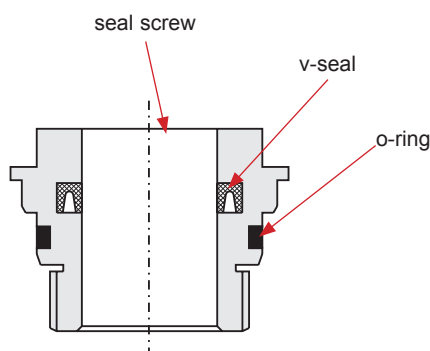

fig. 12.3.



12.1. Maintenance of Actuator

1. Remove the air hoses from the actuator.
2. Remove the inner hexagon screws from the adapter of the control unit. - Remove the adapter.

12.2. Dismantling of seals

1. Unscrew the two seal screws with a spanner SW 30 while holding up the actuator with a strap wrench.
2. Remove o-rings and v-seals.

12.3. Installation of seals and assembly of actuator

1. Die Install the slightly greased o-rings and v-seals in the seal screws (fig. 12.3).
See to the right direction of installation of the v-seal.
2. Push the seal screws over the piston at both sides of the actuator and tighten them.
3. Fasten the adapter of the control unit and the yoke on the actuator.

Attention! Position des Adapters beachten.

Attention! Consider the required valve design NC or NO during the installation of the adapter and the yoke.

NC (FS) = normally closed
(air-to-raise, spring-to-lower)

NO (FH) = normally open
(air-to-lower, spring-to-raise)

4. Fix the air hoses.

10.4. Reconstruction of valve design from normally closed (NC) to normally open (NO)

By turning the actuator by **180°** the required design NC or NO can be selected.

NC (FS) = normally closed (air-to-raise, spring-to-lower)

NO (FH) = normally open (air-to-lower, spring-to-raise)

13. Service Instructions - Assembly Tool

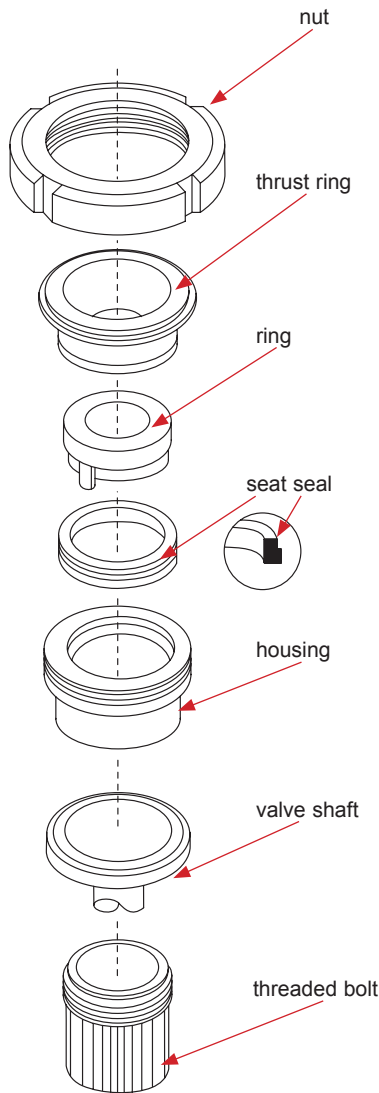

Attention: By means of the assembly tool the seat seal of single seat valves can be installed, only.

The assembly tool consists of:

- nut
- thrust ring
- ring with venting plug
- housing
- threaded bolt

13.1. Installation of the seat seal in the valve shaft

Insert the valve shaft into the housing in such a manner that the seal groove is in the valve housing.

Clamp the shaft in the housing by the threaded bolt. Clamp the housing in a vice.

Slightly grease the seat seal (16) with APV assembly grease. Then pull the seal onto the ring until stop by means of the venting plug.

Introduce the ring with the seat seal into the housing and press it down until it stops.

Insert the thrust ring into the housing. Screw on the nut and tighten it until stop by means of a hook spanner.

Release the nut. Pull the ring and thrust ring out of the housing.

Take the housing out of the vice, unscrew the threaded bolts. Take the valve shaft out of the housing.

Check the correct fit of the seat seal.

13.2. Installation of seat seal for change-over valves

Press the slightly greased seal at four spots, the wide side to the front, into the groove. At the four loops sticking out, the seal must be guided into the groove with a blunt screwdriver, for example, and pressed in by means of strong thumb pressure. Alternately work at all four loops to get an even fit of the seal. Finally the seal is smoothed under strong pressure, e.g. by the handle of a screwdriver and vented by pricking the blade of a screwdriver between the groove edge and seal inner side down to the groove bottom.

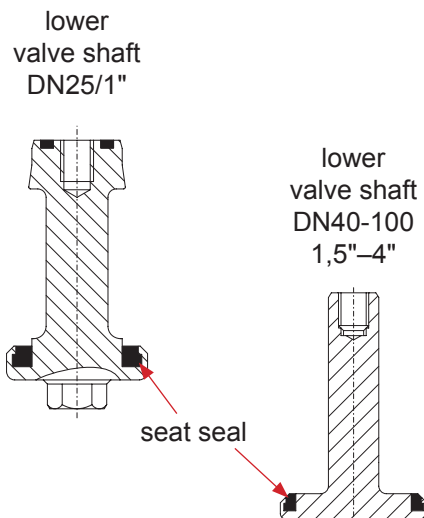

14. Service Instructions - Change-over valves

Change-over valve DELTA MSES4 (NC design)

Change-over valves DELTA MSES 4

The item numbers refer to the spare parts drawings

MSES4: DN design : RN 01.064.12

Inch design: RN 01.064.12-1

14.1. Dismantling from the line system

1. Shut off the line pressure and discharge lines if possible.
2. NC version: Control actuator with air.

Do not touch movable parts!
Risk of injury.

- **Design with control unit:**

Remove the cover of the control unit.

Unscrew the actuator screw and the lock nut (28) while holding up the centering washer (27).

Detach the centering washer.

- **Design with valve position indicator (proximity switch holder):**

Remove the cover (30) of the actuator (23).

Unscrew the actuator screw (29) and the lock nut (28) while holding up the centering washer (27).

Detach the centering washer.

3. Remove the hex. screws (22). Remove the housing cover (20), detach the o-ring (21).

4. Extract the lower valve shaft (3) with guide rod (11) to the bottom out of the housing. In case of stiffness, knock on the guide rod by means of a rubber mallet while manually holding the lower valve shaft. Remove the seat seal (2).

- Only with the valves of the nominal dimensions DN 25 / 1" must the lower valve shaft (3) be unscrewed from the guide rod in the housing. (Use socket key SW 13.)

5. Design NC: Control with air.
Design NO: Shut off air.

Do not touch movable parts!
Risk of injury.

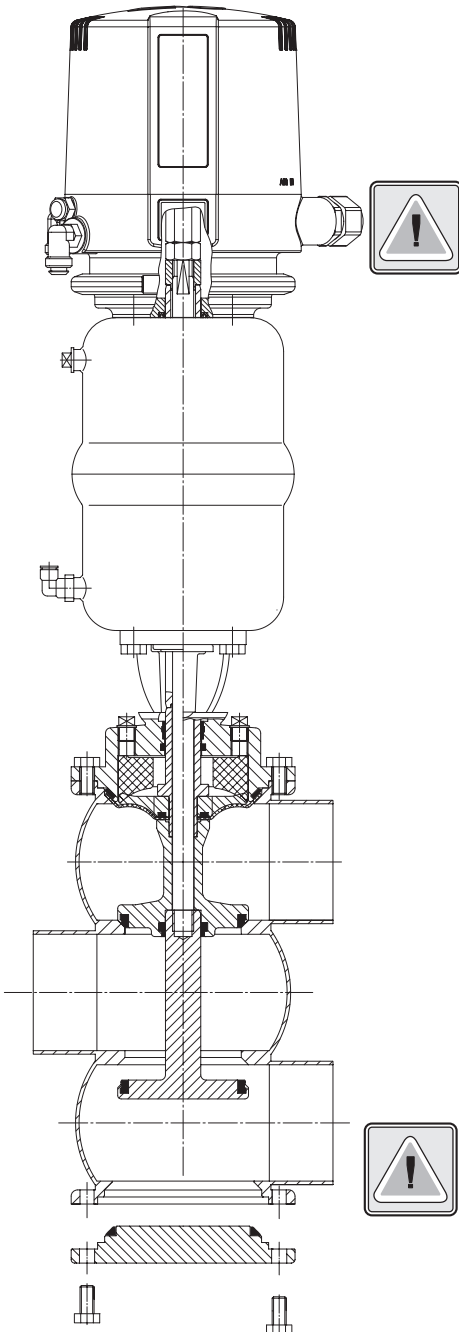

14. Service Instructions - Change-over valves

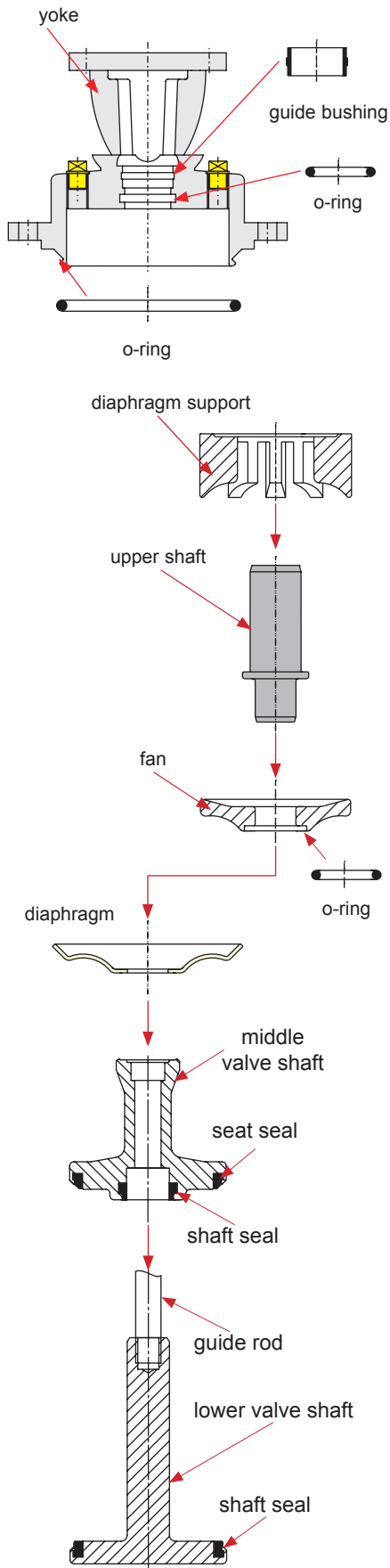

6. Remove the housing screws (17).
7. Lift the actuator (23) with yoke (12) to the top and out of the housing.
8. Remove the middle valve shaft (6), diaphragm (8), fan (9), diaphragm support (10) and upper valve shaft (7).
9. Remove the o-ring (19) from the fan.
10. Remove the seat and shaft seal (4, 5) from the middle valve shaft.
11. Detach the yoke from the actuator.
12. Take the o-rings (18, 16) and guide bush (14) out of the yoke (12).

14.2. Installation of seals and assembly of valve

1. Insert the guide bush (14) and o-ring (16, 18) in the yoke (12).
2. Installation of lower seat seal (2) in the lower valve shaft (3) (see Assembly Tool, page 20).
- **For nominal dimensions DN 25/1" only:**
Place the o-ring (4.1) into the groove of the lower valve shaft.
3. Place the seat and shaft seal (5, 4) into the middle valve shaft (6).
4. Insert the o-ring (19) in the fan (9).
5. Place the diaphragm and fan on the upper shaft.
6. Place the middle valve shaft with diaphragm (8), fan (9) and upper valve shaft (7) from the top into the housing and press the assembly together.
7. Put the diaphragm support into the fan.
- ! **Toothing of fan and diaphragm support must interlock.**
8. Place the yoke onto the housing. Smoothly guide the upper valve shaft through the guide bush into the yoke. In case of stiffness, check the correct fit of the guide bush. Tighten the yoke screws crosswise.

14. Service Instructions - Change-over valves

9. Design NC:

Control the actuator with air.
Fasten the actuator with the hex. screws (13) on the yoke.

- Shut off pneumatic air.

10. Insert the lower valve shaft (3) with guide rod (11) from the bottom into the housing, push it up and keep hold of it.

Only with the valves of the nominal dimensions DN 25 / 1" must the threaded bore of the lower valve shaft be provided with a drop of a screw locker (Loctite) before screwing it together with the guide rod.

Afterwards, push the guide rod (11) from the top through the components and screw it together with the lower shaft (3) in the housing. (tightening torque $M_d = 30 \text{ Nm}$)

11. Place the centering washer (27). Apply a drop of a screw locker (Loctite - semi-solid) on the thread of the guide rod. Screw on the lock nut (28) and tighten it with a tightening torque of $M_d = 40 \text{ Nm}$. Hold up the centering washer during this process.

- **Design with control unit: Tighten the plastic actuator screw.**

! Design with valve position indicator:

Fasten the metallic actuator screw as the lock nut.

12. Insert the o-ring (21) in the housing cover (20) and tighten the housing cover crosswise.

13. Design with control unit:

Place the control unit and fasten it accordingly.

Design with valve position indicator:

Place the proximity switch holder and fasten it accordingly.

Insert the proximity switches and fasten them.

Readjust proximity switches if necessary. .

lower valve shaft
only DN 25 / 1"

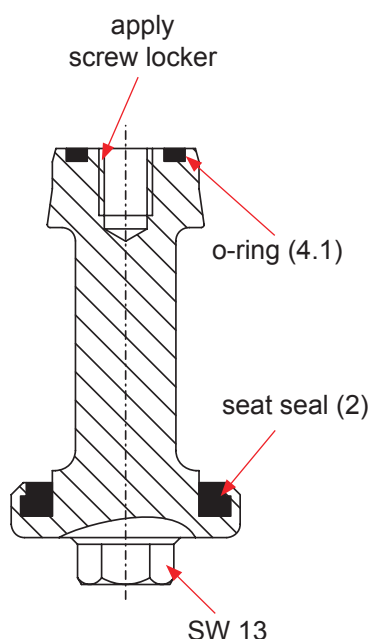

15. Trouble Shooting

Failure	Remedy
Valve closed and pressure in upper housing	
Valve is untight.	Replace seat seal (2). Check line pressure (max. 10bar).
Leakage at the leakage bore in the area of the valve yoke	Check tightening torque of lock nut. Replace diaphragm (5) and o-ring (16).
Leakage between housing and yoke flange	Replace o-rings (15).
Actuator	
Air escapes at the actuator rod.	Replace o-ring (2) at the upper part of the actuator.
Actuator does not work (air escapes permanently from the venting plug).	Replace the complete actuator.
Valve position indication	
No feedback.	Carry out fine adjustment.

16. Spare parts lists

(see annex)

The reference numbers of the spare parts for the different valve designs and sizes are included in the attached spare parts drawings with corresponding lists.

Please indicate the following data to place an order for spare parts:

- required number of parts
- reference number
- designation.

Data are subject to change.

Weitergabe sowie Vervielfältigung dieser Unterlage, Verwertung und Mitteilung ihres Inhalts nicht gestattet, soweit nicht schriftlich zugestanden. Verstößt verpflichtet zum Schadensersatz und kann strafrechtliche Folgen haben (Paragraf 18 UWG, Paragraf 106 UrhG). Eigentum und alle Rechte, auch für Patenterteilung und Gebrauchsmustereintragung, vorbehalten. SPX FLOW, Germany

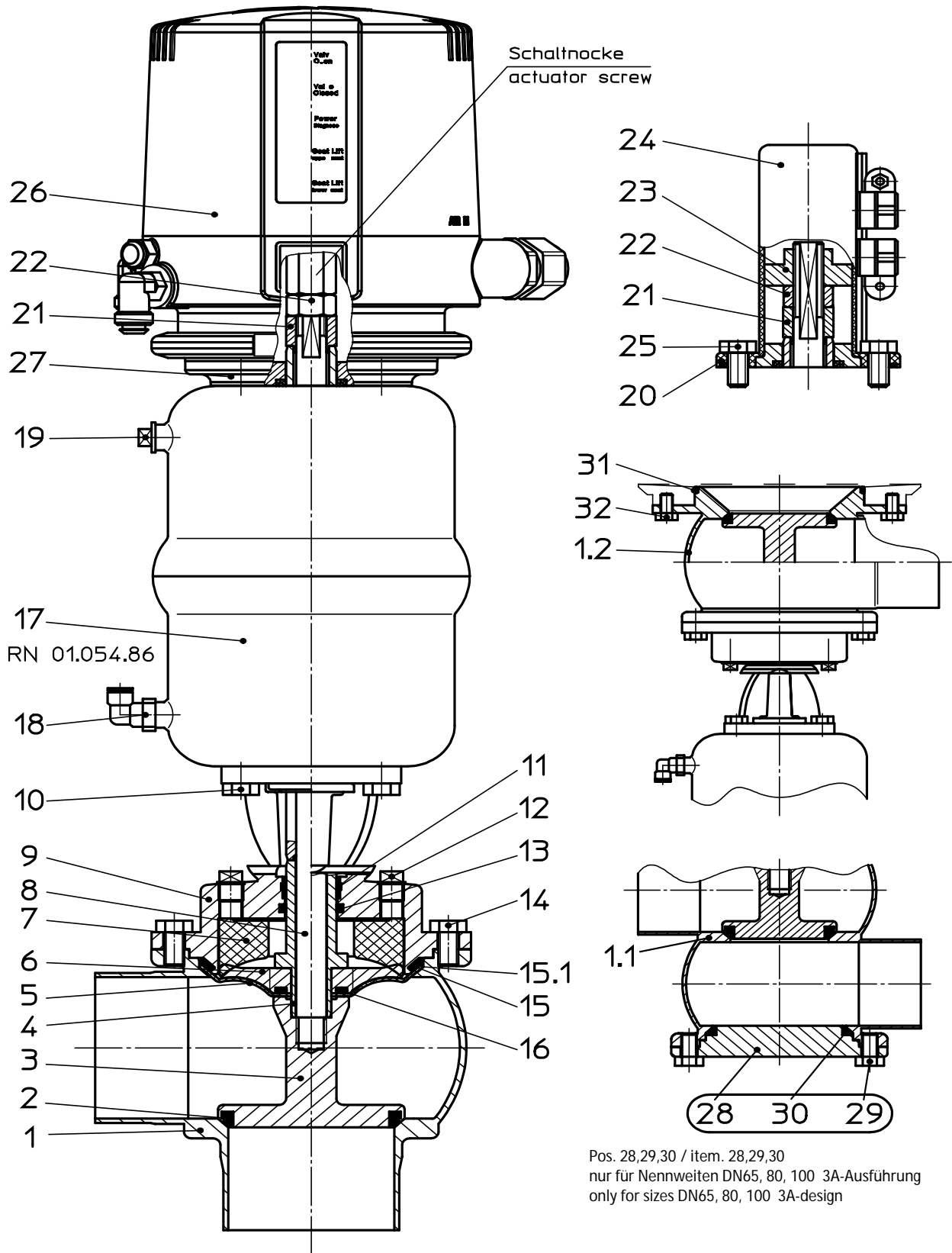

Pos. 18 und 19 nur bei Steuerkopf 3A-Ausführung
item. 18 and 19 only for actuator 3A-design

Pos. 28,29,30 / item. 28,29,30
nur für Nennweiten DN65, 80, 100 3A-Ausführung
only for sizes DN65, 80, 100 3A-design



Datum:	15.06.07	06.03.12	24.09.14	10.06.16						
Name:	Trytko	Trytko	Trytko	Trytko						
Geprüft:	Schulz	Schulz								

Ersatzteilliste: spare parts list

Membranventil fan support MS4, MSE4, MST4 FS-CU und VSM
Diaphragm valve fan support MS4, MSE4, MST4 FS-CU and PSH
DN 25-100



SPX FLOW
Germany

Blatt 1 von 8

RN 01.064.9

Ersatzteilliste: spare parts list

Membranventil fan support MS4, MSE4, MST4 FS-CU und VSM
Diaphragm valve fan support MS4, MSE4, MST4 FS-CU and PSH
DN25-100

Datum:	15.06.07	06.03.12	24.09.14	10.06.16
Name:	Trytko	Trytko	Trytko	Trytko
Geprüft:	Schulz	Schulz		
Datum:				
Name:				
Geprüft:				
Blatt 2 von 8				
RN 01.064.9				

pos. item	Menge quantity	Beschreibung description	Material	DN25	DN40	DN50	DN65	DN80	DN100	
				WS-Nr. ref.-no.	WS-Nr. ref.-no.	WS-Nr. ref.-no.	WS-Nr. ref.-no.	WS-Nr. ref.-no.	WS-Nr. ref.-no.	
1	1	Gehäuse M41 Housing M41 Standardaufs. matt-gl. standard design satin fin.	1.4404	000 39-41-295/47 H173274	000 39-41-395/47 H173275	000 39-41-445/47 H173255	000 39-41-495/47 H173276	000 39-41-545/47 H173277	000 39-41-645/47 H173278	
	1	Gehäuse M42 Housing M42 Standardaufs. matt-gl. standard design satin fin.	1.4404	000 39-42-295/47 H174005	000 39-42-395/47 H174006	000 39-42-445/47 H174009	000 39-42-495/47 H174010	000 39-42-545/47 H174011	000 39-42-645/47 H174012	
	1	Gehäuse M41 Housing M41 Aufs. 3A- außen matt-gl. design 3A- outside-satin fin.	1.4404	3A0 39-41-295/47	3A0 39-41-395/47	3A0 39-41-445/47	3A0 39-41-495/47	3A0 39-41-545/47	3A0 39-41-645/47	
	1	Gehäuse M42 Housing M42 Aufs. 3A- außen matt-gl. design 3A- outside-satin fin.	1.4404	3A0 39-42-295/47	3A0 39-42-395/47	3A0 39-42-445/47	3A0 39-42-495/47	3A0 39-42-545/47	3A0 39-42-645/47	
	1	Gehäuse ME41 Housing ME41 Standardaufs. matt-gl. standard design satin fin.	1.4404	000 39-45-295/47 H179378	000 39-45-395/47 H179379	000 39-45-445/47 H179380	000 39-45-495/47 H179381	000 39-45-545/47 H179382	000 39-45-645/47 H179383	
	1	Gehäuse ME42 Housing ME42 Standardaufs. matt-gl. standard design satin fin.	1.4404	000 39-46-295/47 H179391	000 39-46-395/47 H179392	000 39-46-445/47 H177743	000 39-46-495/47 H179394	000 39-46-545/47 H179395	000 39-46-645/47 H179396	
	1	Gehäuse ME43 Housing ME43 Standardaufs. matt-gl. standard design satin fin.	1.4404	000 39-47-295/47 H179407	000 39-47-395/47 H179409	000 39-47-445/47 H179414	000 39-47-495/47 H179415	000 39-47-545/47 H179416	000 39-47-645/47 H179417	
	1	Gehäuse ME44 Housing ME44 Standardaufs. matt-gl. standard design satin fin.	1.4404	000 39-48-295/47 H179423	000 39-48-395/47 H175166	000 39-48-445/47 H177744	000 39-48-495/47 H175910	000 39-48-545/47 H179424	000 39-48-645/47 H179425	
	1.1	1	Gehäuse ME41 Housing ME41 Aufs. 3A- außen matt-gl. design 3A- outside-satin fin.	1.4404	3A0 39-45-295/47	3A0 39-45-395/47	3A0 39-45-445/47	3A0 39-45-495/47	3A0 39-45-545/47	3A0 39-45-645/47
	1	1	Gehäuse ME42 Housing ME42 Aufs. 3A- außen matt-gl. design 3A- outside-satin fin.	1.4404	3A0 39-46-295/47	3A0 39-46-395/47	3A0 39-46-445/47	3A0 39-46-495/47	3A0 39-46-545/47	3A0 39-46-645/47
	1	1	Gehäuse ME43 Housing ME43 Aufs. 3A- außen matt-gl. design 3A- outside-satin fin.	1.4404	3A0 39-47-295/47	3A0 39-47-395/47	3A0 39-47-445/47	3A0 39-47-495/47	3A0 39-47-545/47	3A0 39-47-645/47
	1	1	Gehäuse ME44 Housing ME44 Aufs. 3A- außen matt-gl. design 3A- outside-satin fin.	1.4404	3A0 39-48-295/47	3A0 39-48-395/47	3A0 39-48-445/47	3A0 39-48-495/47	3A0 39-48-545/47	3A0 39-48-645/47
1.2	1	Gehäuse MT41 Housing MT41 Standardaufs. matt-gl. standard design satin fin.	1.4404	000 39-43-295/47 H175704	000 39-43-395/47 H175708	000 39-43-445/47 H175710	000 39-43-495/47 H175712	000 39-43-545/47 H175714	000 39-43-645/47 H175716	
	1	Gehäuse MT42 Housing MT2 Standardaufs. matt-gl. standard design satin fin.	1.4404	000 39-44-295/47 H175705	000 39-44-395/47 H175709	000 39-44-445/47 H175711	000 39-44-495/47 H175713	000 39-44-545/47 H175715	000 39-44-645/47 H175717	
	1	Gehäuse MT41 Housing MT41 Aufs. 3A- außen matt-gl. design 3A- outside-satin fin.	1.4404	3A0 39-43-295/47	3A0 39-43-395/47	3A0 39-43-445/47	3A0 39-43-495/47	3A0 39-43-545/47	3A0 39-43-645/47	
	1	Gehäuse MT42 Housing MT42 Aufs. 3A- außen matt-gl. design 3A- outside-satin fin.	1.4404	3A0 39-44-295/47	3A0 39-44-395/47	3A0 39-44-445/47	3A0 39-44-495/47	3A0 39-44-545/47	3A0 39-44-645/47	
	1	Gehäuse MT41 Housing MT41 Standardaufs. matt-gl. standard design satin fin.	1.4404	000 39-43-295/47 H175704	000 39-43-395/47 H175708	000 39-43-445/47 H175710	000 39-43-495/47 H175712	000 39-43-545/47 H175714	000 39-43-645/47 H175716	
	1	Gehäuse MT42 Housing MT2 Standardaufs. matt-gl. standard design satin fin.	1.4404	000 39-44-295/47 H175705	000 39-44-395/47 H175709	000 39-44-445/47 H175711	000 39-44-495/47 H175713	000 39-44-545/47 H175715	000 39-44-645/47 H175717	



Ersatzteilliste: spare parts list

**Membranventil fan support MS4, MSE4, MST4 FS-CU und VSM
Diaphragm valve fan support MS4, MSE4, MST4 FS-CU and PSH
DN25-100**

pos. item	Menge quantity	Beschreibung description	Material	DN25	DN40	DN50	DN65	DN80	DN100	
				WS-Nr. ref.-no.	WS-Nr. ref.-no.	WS-Nr. ref.-no.	WS-Nr. ref.-no.	WS-Nr. ref.-no.	WS-Nr. ref.-no.	
1	1	Gehäuse M41 Housing M41 Ausf. außen-polliert design outside-polished	1.4404	000 39-41-295/43	000 39-41-395/43	000 39-41-445/43	000 39-41-495/43	000 39-41-545/43	000 39-41-645/43	
	1	Gehäuse M42 Housing M42 Ausf. außen-polliert design outside-polished	1.4404	000 39-42-295/43	000 39-42-395/43	000 39-42-445/43	000 39-42-495/43	000 39-42-545/43	000 39-42-645/43	
	1	Gehäuse M41 Housing M41 Ausf. außen- 3A-Standard design outside -3A-standard	1.4404	3A0 39-41-295/43 H320478	3A0 39-41-395/43 H320285	3A0 39-41-445/43 H320305	3A0 39-41-495/43 H320140	3A0 39-41-545/43 H320327	3A0 39-41-645/43 H320384	
	1	Gehäuse M42 Housing M42 Ausf. außen- 3A-Standard design outside -3A-standard	1.4404	3A0 39-42-295/43	3A0 39-42-395/43	3A0 39-42-445/43	3A0 39-42-495/43	3A0 39-42-545/43	3A0 39-42-645/43	
	1	Gehäuse ME41 Housing ME41 Ausf. außen-polliert design outside-polished	1.4404	000 39-45-295/43	000 39-45-395/43	000 39-45-445/43	000 39-45-495/43	000 39-45-545/43	000 39-45-645/43	
	1	Gehäuse ME42 Housing ME42 Ausf. außen-polliert design outside-polished	1.4404	000 39-46-295/43	000 39-46-395/43	000 39-46-445/43	000 39-46-495/43	000 39-46-545/43	000 39-46-645/43	
	1	Gehäuse ME43 Housing ME43 Ausf. außen-polliert design outside-polished	1.4404	000 39-47-295/43	000 39-47-395/43	000 39-47-445/43	000 39-47-495/43	000 39-47-545/43	000 39-47-645/43	
	1	Gehäuse ME44 Housing ME44 Ausf. außen-polliert design outside-polished	1.4404	000 39-48-295/43	000 39-48-395/43	000 39-48-445/43	000 39-48-495/43	000 39-48-545/43	000 39-48-645/43	
	1.1	1	Gehäuse ME41 Housing ME41 Ausf. außen- 3A-Standard design outside -3A-standard	1.4404	3A0 39-45-295/43	3A0 39-45-395/43	3A0 39-45-445/43	3A0 39-45-495/43	3A0 39-45-545/43	3A0 39-45-645/43
	1	1	Gehäuse ME42 Housing ME42 Ausf. außen- 3A-Standard design outside -3A-standard	1.4404	3A0 39-46-295/43	3A0 39-46-395/43	3A0 39-46-445/43	3A0 39-46-495/43	3A0 39-46-545/43	3A0 39-46-645/43
	1	1	Gehäuse ME43 Housing ME43 Ausf. außen- 3A-Standard design outside -3A-standard	1.4404	3A0 39-47-295/43	3A0 39-47-395/43	3A0 39-47-445/43	3A0 39-47-495/43	3A0 39-47-545/43	3A0 39-47-645/43
	1	1	Gehäuse ME44 Housing ME44 Ausf. außen- 3A-Standard design outside -3A-standard	1.4404	3A0 39-48-295/43	3A0 39-48-395/43	3A0 39-48-445/43	3A0 39-48-495/43	3A0 39-48-545/43	3A0 39-48-645/43
1.2	1	Gehäuse MT41 Housing MT41 Ausf. außen-polliert design outside-polished	1.4404	000 39-43-295/43	000 39-43-395/43	000 39-43-445/43	000 39-43-495/43	000 39-43-545/43	000 39-43-645/43	
	1	Gehäuse MT42 Housing MT2 Ausf. außen-polliert design outside-polished	1.4404	000 39-44-295/43	000 39-44-395/43	000 39-44-445/43	000 39-44-495/43	000 39-44-545/43	000 39-44-645/43	
	1	Gehäuse MT41 Housing MT41 Ausf. außen- 3A-Standard design outside -3A-standard	1.4404	3A0 39-43-295/43	3A0 39-43-395/43	3A0 39-43-445/43	3A0 39-43-495/43	3A0 39-43-545/43	3A0 39-43-645/43	
	1	Gehäuse MT42 Housing MT42 Ausf. außen- 3A-Standard design outside -3A-standard	1.4404	3A0 39-44-295/43	3A0 39-44-395/43	3A0 39-44-445/43	3A0 39-44-495/43	3A0 39-44-545/43	3A0 39-44-645/43	
	1	Gehäuse MT41 Housing MT41 Ausf. außen-polliert design outside-polished	1.4404	000 39-43-295/43	000 39-43-395/43	000 39-43-445/43	000 39-43-495/43	000 39-43-545/43	000 39-43-645/43	
	1	Gehäuse MT42 Housing MT42 Ausf. außen-polliert design outside-polished	1.4404	000 39-44-295/43	000 39-44-395/43	000 39-44-445/43	000 39-44-495/43	000 39-44-545/43	000 39-44-645/43	

Datum:	15.06.07	06.03.12	24.09.14	10.06.16
Name:	Trytko	Trytko	Trytko	Trytko
Geprüft:	Schulz	Schulz		

Datum:				
Name:				
Geprüft:				

Blatt	3	von	8
RN 01.064.9			



Weitergabe sowie Vervielfältigung dieser Unterlage, Verwertung und Mitteilung ihres Inhalts nicht gestattet, soweit nicht schriftlich zugestanden. Verstoß verpflichtet zum Schadensersatz und kann strafrechtliche Folgen haben (Paragraf 18 UWG, Paragraf 106 UrnG). Eigentum und alle Rechte, auch für Patenterteilung und Gebrauchsmusterteiltragung, vorbehalten. SPX FLOW, Germany

Ersatzteilliste: spare parts list

Membranventil fan support MS4, MSE4, MST4 FS-CU und VSM Diaphragm valve fan support MS4, MSE4, MST4 FS-CU and PSH DN25-100

pos. item	Menge quantity	Beschreibung description	Material	DN25	DN40	DN50	DN65	DN80	DN100
				WS-Nr. ref.-no.	WS-Nr. ref.-no.	WS-Nr. ref.-no.	WS-Nr. ref.-no.	WS-Nr. ref.-no.	WS-Nr. ref.-no.
1	1	Tellerdichtung Seat seal	EPDM FDA-konform	58-33-293/93 H77442	58-33-393/93 H77467	58-33-443/93 H77491	58-33-493/93 H77515	58-33-543/93 H77546	58-33-643/93 H77586
				58-33-293/73 H77441	58-33-393/73 H77466	58-33-443/73 H77490	58-33-493/73 H77514	58-33-543/73 H77545	58-33-643/73 H77585
2	1	Tellerdichtung Seat seal	HNBR FDA-konform	58-33-293/33 H170176	58-33-393/33 H166676	58-33-443/33 H166085	58-33-493/33 H166678	58-33-543/33 H166681	58-33-643/33 H166682
				58-33-293/13 H77440	58-33-393/13 H77465	58-33-443/13 H77489	58-33-493/13 H77513	58-33-543/13 H77544	58-33-643/13 H77584
3	1	Schaft unten Lower valve shaft	1.4404	3A0 39-22-295/43 H320422	3A0 39-22-395/43 H320291	3A0 39-22-445/43 H320311	3A0 39-22-495/43 H207033	3A0 39-22-545/43 H207034	3A0 39-22-645/43 H207035
				39-22-070/12 H318486	39-22-071/12 H318487	39-22-072/12 H318488	39-22-073/12 H318489	39-22-074/12 H318490	
4	1	Schaft oben Upper valve shaft	1.4301	58-23-050/23 H318545	58-23-051/23 H318544	58-23-052/23 H318543	58-23-053/23 H318542	58-23-054/23 H318541	58-23-055/23 H318540
				08-48-520/12 H320414	08-48-521/12 H320249	08-48-522/12 H319397	08-48-523/12 H320316	08-48-524/12 H320332	
5	1	Membrane Diaphragm	TFM FDA-konform	08-48-510/93 H318532	08-48-511/93 H318533	08-48-512/93 H318534	08-48-513/93 H318535	08-48-514/93 H318536	08-48-515/93 H318537
				39-23-080/12 H202599	39-23-129/12 H320621	39-23-083/12 H202608	000 39-40-043/47 H318493	000 39-40-044/47 H320578	
6	1	Stern Star	1.4301	000 39-40-040/47 H318491	000 39-40-041/47 H318492	000 39-40-042/47 H318493	000 39-40-043/47 H318494	000 39-40-044/47 H320578	000 39-40-045/47 H320579
				000 39-40-040/43	000 39-40-041/43	000 39-40-042/43	000 39-40-043/43	000 39-40-044/43	
7	1	Membranunterstützung Fan support	Ryton R4-XT	08-48-510/93 H318532	08-48-511/93 H318533	08-48-512/93 H318534	08-48-513/93 H318535	08-48-514/93 H318536	08-48-515/93 H318537
				39-23-080/12 H202599	39-23-129/12 H320621	39-23-083/12 H202608	000 39-40-043/47 H318493	000 39-40-044/47 H320578	
8	1	Zugstange Guide rod	1.4305	000 39-40-040/47 H318491	000 39-40-041/47 H318492	000 39-40-042/47 H318493	000 39-40-043/47 H318494	000 39-40-044/47 H320578	000 39-40-045/47 H320579
				000 39-40-040/43	000 39-40-041/43	000 39-40-042/43	000 39-40-043/43	000 39-40-044/43	
9	1	Laterne Yoke	1.4404	08-48-510/93 H318532	08-48-511/93 H318533	08-48-512/93 H318534	08-48-513/93 H318535	08-48-514/93 H318536	08-48-515/93 H318537
				39-23-080/12 H202599	39-23-129/12 H320621	39-23-083/12 H202608	000 39-40-043/47 H318493	000 39-40-044/47 H320578	
10	4	Skt. Schraube Hex. Screw	1.4404	000 39-40-040/47 H318491	000 39-40-041/47 H318492	000 39-40-042/47 H318493	000 39-40-043/47 H318494	000 39-40-044/47 H320578	000 39-40-045/47 H320579
				000 39-40-040/43	000 39-40-041/43	000 39-40-042/43	000 39-40-043/43	000 39-40-044/43	
11	1	Führungsbuchse Bushing	1.4404	08-01-177/23 H162714	08-01-178/23 H207154	08-01-179/23 H319373	08-01-180/23 H319374	08-01-181/23 H320320	08-01-182/23 H318495
				08-01-177/23 H162714	08-01-178/23 H207154	08-01-179/23 H319373	08-01-180/23 H319374	08-01-181/23 H320320	
12	1	Führungsbuchse Bushing	KETRON PEEK	08-01-177/23 H162714	08-01-178/23 H207154	08-01-179/23 H319373	08-01-180/23 H319374	08-01-181/23 H320320	08-01-182/23 H318495
				08-01-177/23 H162714	08-01-178/23 H207154	08-01-179/23 H319373	08-01-180/23 H319374	08-01-181/23 H320320	



Blatt 4 von 8
RN 01.064.9

Weitergabe sowie Vervielfältigung dieser Unterlage, Verwertung und Mitteilung ihres Inhalts nicht gestattet, soweit nicht schriftlich zugestanden. Verstoß verpflichtet zum Schadensersatz und kann strafrechtliche Folgen haben (Paragraf 18 UWG, Paragraf 106 UrhG). Eigentum und alle Rechte, auch für Patenterteilung und Gebrauchsmustereintragung, vorbehalten. SPX FLOW, Germany

Ersatzteilliste: spare parts list

**Membranventil fan support MS4, MSE4, MST4 FS-CU und VSM
Diaphragm valve fan support MS4, MSE4, MST4 FS-CU and PSH
DN25-100**

Datum:	15.06.07	06.03.12	24.09.14	10.06.16
Name:	Trytko	Trytko	Trytko	Trytko
Geprüft:	Schulz	Schulz		
Datum:				
Name:				
Geprüft:				

Blatt 5 von 8				
RN 01.064.9				



pos. item	Menge quantity	Beschreibung description	Material	DN25	DN40	DN50	DN65	DN80	DN100
12	2	Entlüftungstopfen Venting plug	PHT/BLACK						
13	1	O-Ring O-ring	EPDM FDA-konform	58-06-052/64 15,3x2,4 H206007			58-06-078/64 20,2x3 H121794		
14		Skt. Schraube Hex. Screw	1.4301	65-01-055/13 4xM6x12 H78750	65-01-081/15 4xM8x16 H78772			65-01-130/15 8xM10x16 H78806	
15	1	O-Ring O-ring	EPDM FDA-konform	58-06-154/64 35x2,5 H320272	58-06-277/64 60x3 H320262		58-06-347/64 76x3,5 H319391	58-06-491/64 100x3,5 H320273	58-06-580/64 120x3,5 H320274
15.1	1	O-Ring O-ring	EPDM FDA-konform	58-06-144/64 35x3,5 H324909	58-06-269/64 60x4 H324910		58-06-340/64 75x4,5 H324911	58-06-488/64 95x4,5 H324912	58-06-581/64 120x4,5 H324913
16	1	O-Ring O-ring	EPDM FDA-konform	58-06-038/64 11x2,5 H320269	58-06-067/64 18x3 H320261		58-06-083/64 22x3,5 H319390	58-06-098/64 24x3,5 H320270	58-06-140/64 31,1x3,5 H320271
17	1	Steuerkopf Actuator	1.4301	000 15-32-050/17 H171378	000 15-32-051/17 H171379			000 15-32-052/17 H171380	
17	1	Steuerkopf Actuator	1.4301	000 15-32-050/13 H178155	000 15-32-051/13 H177400			000 15-32-052/13 H200827	
17	1	Steuerkopf Actuator	1.4301	3A0 15-32-059/13 H208693	3A0 15-32-060/13 H173538			3A0 15-32-061/13 H173524	
18	1	W-Versch. schwenk. W-Union slewable	PA-1.4301			08-60-811/93 H312732			
19	1	Entlüftungstopfen Venting plug	PE-HARD YELLOW			08-60-005/93 H16218			
20	1	O-Ring O-ring	NBR 70-75 Shore A			58-06-297/83 H173930			
21	1	Zentrierscheibe Centering nut	1.4301			15-28-940/12 H170196			
22	1	Skt. Mutter Hex. Nut	1.4301			65-50-105/15 H112376			
23	1	Schaltnocke Operating cam	1.4523	08-52-290/97 H173086			08-52-291/97 H173087		
24	1	VSM Gehäuse Proximity switch holder housing	Vestamid						

Weitergabe sowie Vervielfältigung dieser Unterlage, Verwertung und Mitteilung ihres Inhalts nicht gestattet, soweit nicht schriftlich zugestanden. Verstöß verpflichtet zum Schadensersatz und kann strafrechtliche Folgen haben (Paragraf 18 UWG, Paragraf 106 UrtG). Eigentum und alle Rechte, auch für Patenterteilung und Gebrauchsmustereintragung, vorbehalten. SPX FLOW, Germany

Ersatzteilliste: spare parts list

Membranventil fan support MS4, MSE4, MST4 FS-CU und VSM Diaphragm valve fan support MS4, MSE4, MST4 FS-CU and PSH DN25-100

pos. item	Menge quantity	Beschreibung description	Material	DN25	DN40	DN50	DN65	DN80	DN100
				WS-Nr. ref.-no.	WS-Nr. ref.-no.	WS-Nr. ref.-no.	WS-Nr. ref.-no.	WS-Nr. ref.-no.	WS-Nr. ref.-no.
25	4	Skt. Schraube Hex. Screw DIN EN 24017 M8x16 -A2-70	1.4301						
26	1	Control-Unit Control-Unit CU41-S-Direckt Connect	PA 6.6 GF 30 schwarz						
27	1	CU4-S-Adapter CU4-S-adapter	PA 6.6 GF 30 schwarz						
28	1	Gehäusedeckel Housing lid	1.4404						
	1	Gehäusedeckel Housing lid	1.4404						
29		Skt. Schraube Hex. screw DIN EN 24017-A2-70	1.4301						
30	1	O-Ring	EPDM						
	1	O-ring	FDA-konform						
	1	O-Ring	FPM						
	1	O-ring	FDA-konform						
31	1	Gehäusedichtung Housing seal	EPDM	58-33-392/93 H77464	58-33-442/93 H77488	58-33-492/93 H77512	58-33-542/93 H77543	58-33-642/93 H77583	58-33-692/93 H77608
	1	Gehäusedichtung Housing seal	FPM	58-33-392/73 H77463	58-33-442/73 H77487	58-33-492/73 H77511	58-33-542/73 H77542	58-33-642/73 H77582	58-33-692/73 H77607
32	1	Gehäusedichtung Housing seal	HNBR	58-33-392/33 H170018	58-33-442/33 H168714	58-33-492/33 H168759	58-33-542/33 H170075	58-33-642/33 H170074	58-33-692/33 H172125
		Skt. Schraube Hex. screw DIN EN 24017-A2-70	1.4301	65-01-079/15 M8x14 H78768	65-01-079/15 M10x14 H78805	65-01-129/15	65-01-130/15	65-01-140/47 M10x14 H78805	65-01-143/47 M10x14 H78805



Blatt 6 von 8
RN 01.064.9

Datum: 15.06.07
Name: Trytko
Geprüft: Schulz
10.06.16
Trytko
Trytko
Schulz

Datum: 06.03.12
Name: Trytko
Geprüft: Schulz
24.09.14
Trytko
Trytko
Schulz

Datum: 15.06.07
Name: Trytko
Geprüft: Schulz
10.06.16
Trytko
Trytko
Schulz

Weitergabe sowie Vervielfältigung dieser Unterlage, Verwertung und Mitteilung ihres Inhalts nicht gestattet, soweit nicht schriftlich zugestanden. Verstößt verpflichtet zum Schadensersatz und kann strafrechtliche Folgen haben (Paragraf 18 UWG, Paragraf 106 UrhG). Eigentum und alle Rechte, auch für Patenterteilung und Gebrauchsmustereintragung, vorbehalten. SPX FLOW, Germany

Ersatzteilliste: spare parts list

Membranventil fan support MS4, MSE4, MST4 FS-CU und VSM Diaphragm valve fan support MS4, MSE4, MST4 FS-CU and PSH DN25-100

Datum:		15.06.07	06.03.12	24.09.14	10.06.16
Name:	Trytko	Trytko	Trytko	Trytko	Trytko
Geprüft:	Schulz	Schulz			
Datum:					Blatt 7 von 8
Name:					RN 01.064.9
Geprüft:					

pos. item	Menge quantity	Beschreibung description	Material	DN25	DN40	DN50	DN65	DN80	DN100
				WS-Nr. ref.-no.	WS-Nr. ref.-no.	WS-Nr. ref.-no.	WS-Nr. ref.-no.	WS-Nr. ref.-no.	WS-Nr. ref.-no.

Dichtungssatz MS4, MSE4 Standardausführung / seal kit MS4, MSE4 standard design Pos. 2, 5, 11, 13, 15, 16, 22 / Item 2, 5, 11, 13, 15, 16, 22 available es complete seal kits only									
1	1	Dichtungssatz Seal kit	TFM / FPM	58-36-780/00 H328328	58-36-781/00 H324515	58-36-782/00	58-36-783/00 H324514	58-36-784/00	58-36-785/00
	1	Dichtungssatz Seal kit	TFM / EPDM	58-36-780/01 H322888	58-36-781/01 H322889	58-36-782/01 H322890	58-36-783/01 H322891	58-36-784/01 H322892	58-36-785/01 H322893
	1	Dichtungssatz Seal kit	TFM / VMQ	58-36-780/02	58-36-781/02	58-36-782/02	58-36-783/02	58-36-784/02	58-36-785/02
	1	Dichtungssatz Seal kit	TFM / HNBR	58-36-780/06 H332211	58-36-781/06	58-36-782/06 H327691	58-36-783/06	58-36-784/06	58-36-785/06

Dichtungssatz MS4, MSE4 Standardausführung / seal kit MS4, MSE4 standard design Pos. 2, 5, 11, 13, 15.1, 16, 22 / Item 2, 5, 11, 13, 15.1, 16, 22 available es complete seal kits only									
2	1	Dichtungssatz Seal kit	TFM / FPM	58-36-920/00	58-36-921/00 H331957	58-36-922/00 H329916	58-36-923/00 H329273	58-36-924/00	58-32-925/00
	1	Dichtungssatz Seal kit	TFM / EPDM	58-36-920/01 H324944	58-36-921/01 H324945	58-36-922/01 H324946	58-36-923/01 H324947	58-36-924/01 H324948	58-36-925/01 H324949
	1	Dichtungssatz Seal kit	TFM / VMQ	58-36-920/02	58-36-921/02	58-36-922/02	58-36-923/02	58-36-924/02	58-36-925/02
	1	Dichtungssatz Seal kit	TFM / HNBR	58-36-920/06 H329966	58-36-921/06 H329274	58-36-922/06 H328730	58-36-923/06 H329272	58-36-924/06	58-36-925/06 H329967

Dichtungssatz MS4 Ausführung -3A / seal kit MS4 design -3A Pos. 2, 5, 11, 13, 15, 16, 22 / Item 2, 5, 11, 13, 15, 16, 22 available es complete seal kits only									
1	1	Dichtungssatz Seal kit	TFM / FPM	3A0 58-36-780/00	3A0 58-36-781/00	3A0 58-36-782/00	3A0 58-36-783/00	3A0 58-36-784/00	3A0 58-36-785/00
	1	Dichtungssatz Seal kit	TFM / EPDM	3A0 58-36-780/01 H322881	3A0 58-36-781/01 H322882	3A0 58-36-782/01 H322883	3A0 58-36-783/01 H322884	3A0 58-36-784/01 H322885	3A0 58-36-785/01 H322887
	1	Dichtungssatz Seal kit	TFM / VMQ	3A0 58-36-780/02	3A0 58-36-781/02	3A0 58-36-782/02	3A0 58-36-783/02	3A0 58-36-784/02	3A0 58-36-785/02
	1	Dichtungssatz Seal kit	TFM / HNBR	3A0 58-36-780/06	3A0 58-36-781/06	3A0 58-36-782/06	3A0 58-36-783/06	3A0 58-36-784/06	3A0 58-36-785/06



Weitergabe sowie Vervielfältigung dieser Unterlage, Verwertung und Mitteilung ihres Inhalts nicht gestattet, soweit nicht schriftlich zugestanden. Verstößt verpflichtet zum Schadensersatz und kann strafrechtliche Folgen haben (Paragraf 18 UWG, Paragraf 106 UrhG). Eigentum und alle Rechte, auch für Patenterteilung und Gebrauchsmustereintragung, vorbehalten. SPX FLOW, Germany

Ersatzteilliste: spare parts list

Membranventil fan support MS4, MSE4, MST4 FS-CU und VSM Diaphragm valve fan support MS4, MSE4, MST4 FS-CU and PSH DN25-100

Datum:	15.06.07	06.03.12	24.09.14	10.06.16
Name:	Trytko	Trytko	Trytko	Trytko
Geprüft:	Schulz	Schulz		



Datum:					Blatt	8	von	8
Name:					RN 01.064.9			
Geprüft:								

pos. item	Menge quantity	Beschreibung description	Material	DN25	DN40	DN50	DN65	DN80	DN100
			WS-Nr. ref.-no.	WS-Nr. ref.-no.	WS-Nr. ref.-no.	WS-Nr. ref.-no.	WS-Nr. ref.-no.	WS-Nr. ref.-no.	WS-Nr. ref.-no.
Dichtungssatz MS4 Ausführung -3A / seal kit MS4 design -3A									
Pos. 2, 5, 11, 13, 15.1, 16, 22 / Item 2, 5, 11, 13, 15.1, 16, 22 available es complete seal kits only									
1		Dichtungssatz Seal kit	TFM / FPM	3A0 58-36-920/00	3A0 58-36-921/00	3A0 58-36-922/00	3A0 58-36-923/00 H329365	3A0 58-36-924/00	3A0 58-32-925/00
1		Dichtungssatz Seal kit	TFM / EPDM	3A0 58-36-920/01 H324951	3A0 58-36-921/01 H324952	3A0 58-36-922/01 H324953	3A0 58-36-923/01 H324954	3A0 58-36-924/01 H324955	3A0 58-36-925/01 H324956
1		Dichtungssatz Seal kit	TFM / VMQ	3A0 8-36-920/02	3A0 58-36-921/02	3A0 58-36-922/02	3A0 58-36-923/02	3A0 58-36-924/02	3A0 58-36-925/02
1		Dichtungssatz Seal kit	TFM / HNBR	3A0 58-36-920/06	3A0 58-36-921/06 H328097	3A0 58-36-922/06 H328107	3A0 58-36-923/06 H328108	3A0 58-36-924/06	3A0 58-36-925/06
Dichtungssatz MSE4 Ausführung -3A / seal kit MSE4 design -3A									
Pos. 2, 5, 11, 13, 15.1, 16, 22, 30 / Item 2, 5, 11, 13, 15.1, 16, 22, 30 available es complete seal kits only									
1		Dichtungssatz Seal kit	TFM / FPM				3A0 58-36-928/00	3A0 58-36-929/00	3A0 58-36-930/00
1		Dichtungssatz Seal kit	TFM / EPDM				3A0 58-36-928/01	3A0 58-36-929/01	3A0 58-36-930/01
1		Dichtungssatz Seal kit	TFM / VMQ				3A0 58-36-928/02	3A0 58-36-929/02	3A0 58-36-930/02
1		Dichtungssatz Seal kit	TFM / HNBR				3A0 58-36-928/06	3A0 58-36-929/06	3A0 58-36-930/06
Dichtungssatz MST4 Standardausführung / seal kit MST4 standard design									
Pos. 2, 5, 11, 13, 15.1, 16, 22, 31 / Item 2, 5, 11, 13, 15.1, 16, 22, 31 available es complete seal kits only									
1		Dichtungssatz Seal kit	TFM / FPM	58-36-941/00	58-36-942/00	58-36-943/00	58-36-944/00	58-36-945/00	58-32-946/00
1		Dichtungssatz Seal kit	TFM / EPDM	58-36-941/01	58-36-942/01	58-36-943/01	58-36-944/01	58-36-945/01	58-36-946/01
1		Dichtungssatz Seal kit	TFM / VMQ	58-36-941/02	58-36-942/02	58-36-943/02	58-36-944/02	58-36-945/02	58-36-946/02
1		Dichtungssatz Seal kit	TFM / HNBR	58-36-941/06	58-36-942/06	58-36-943/06	58-36-944/06	58-36-945/06	58-36-946/06

2

Weitergabe sowie Vervielfältigung dieser Unterlage, Verwertung und Mitteilung ihres Inhalts nicht gestattet, soweit nicht schriftlich zugestanden. Verstöße verpflichten zum Schadensersatz und kann strafrechtliche Folgen haben (Paragraf 18 UWG, Paragraf 106 UrhG). Eigentum und alle Rechte, auch für Patenterteilung und Gebrauchsmustereintragung, vorbehalten. SPX FLOW, Germany

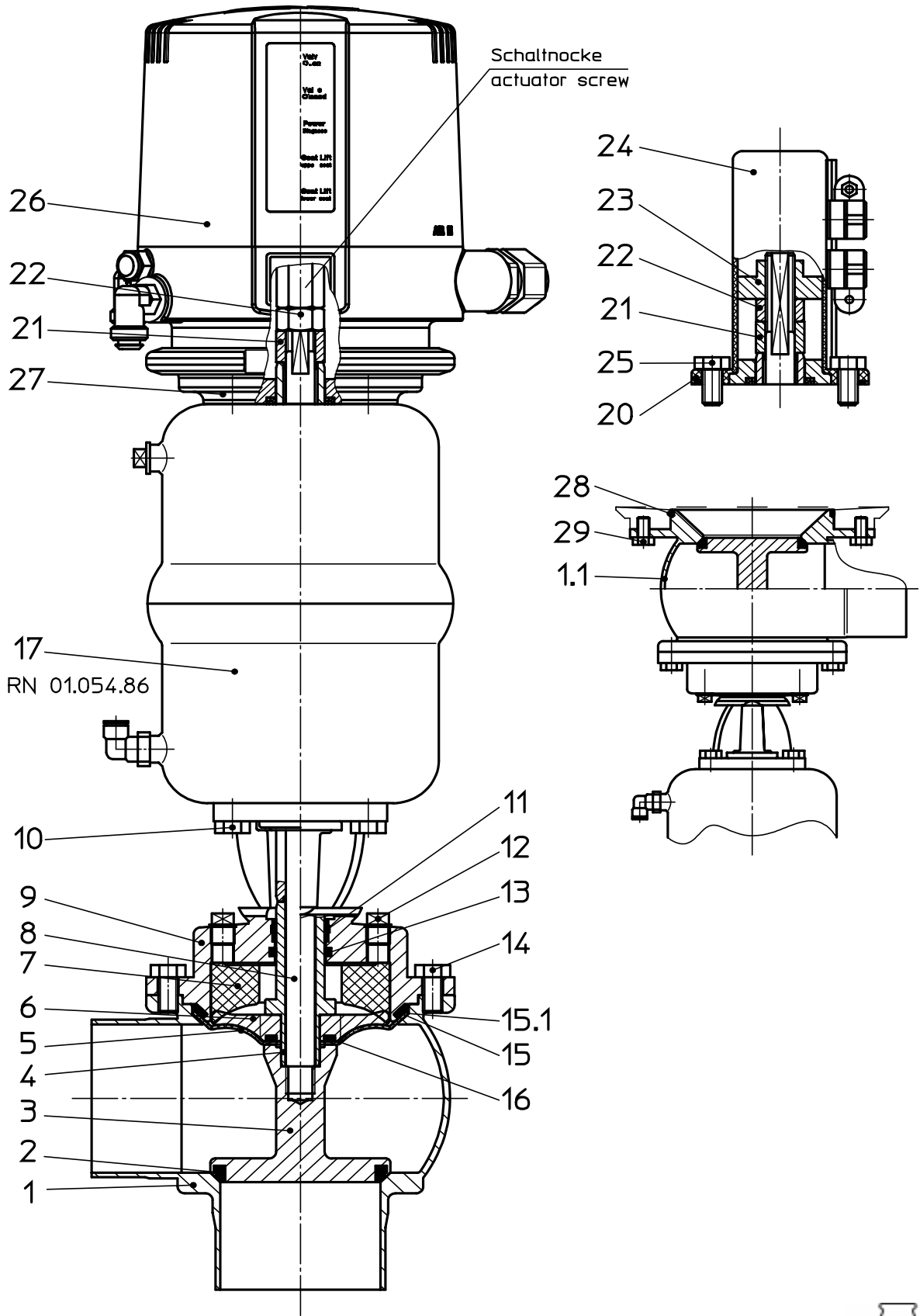

Datum:	28.06.07	09.03.12	26.09.14	10.06.16					
Name:	Trytko	Trytko	Trytko	Trytko					
Geprüft:	Schulz	Schulz							

Ersatzteilliste: spare parts list

Membranventil fan support MS4, MSE4, MST4 FS-CU und VSM
Diaphragm valve fan support MS4, MSE4, MST4 FS-CU and PSH
1-4 Zoll / inch

APV

SPX FLOW
Germany

Blatt 1 von 6

RN 01.064.9-1

Weitergabe sowie Vervielfältigung dieser Unterlage, Verwertung und Mitteilung ihres Inhalts nicht gestattet, soweit nicht schriftlich zugestanden. Verstößt verpflichtet zum Schadensersatz und kann strafrechtliche Folgen haben. (Paragraph 18 UWG, Paragraph 106 UrhG). Eigentum und alle Rechte, auch für Patenterteilung und Gebrauchsmustereintragung, vorbehalten. SPX FLOW, Germany

Ersatzteilliste: spare parts list

Membranventil fan support MS4, MSE4, MST4 FS-CU und VSM Diaphragm valve fan support MS4, MSE4, MST4 FS-CU and PSH 1-4 Zoll / inch

pos. item	Menge quantity	Beschreibung description	Material	1.5"				2"				2,5"				3"				4"			
				WS-Nr. ref.-no.	WS-Nr. ref.-no.	WS-Nr. ref.-no.	WS-Nr. ref.-no.	WS-Nr. ref.-no.	WS-Nr. ref.-no.	WS-Nr. ref.-no.	WS-Nr. ref.-no.	WS-Nr. ref.-no.	WS-Nr. ref.-no.	WS-Nr. ref.-no.	WS-Nr. ref.-no.	WS-Nr. ref.-no.	WS-Nr. ref.-no.	WS-Nr. ref.-no.	WS-Nr. ref.-no.	WS-Nr. ref.-no.	WS-Nr. ref.-no.		
	1	Gehäuse M41 Housing M41	1.4404	000 39-41-320/47 H174026	000 39-41-420/47 H174156	000 39-41-470/47 H174105	000 39-41-520/47 H174173	000 39-41-570/47 H174175	000 39-41-670/47 H174028														
	1	Gehäuse M42 Housing M42	1.4404	000 39-42-320/47 H174132	000 39-42-420/47 H174157	000 39-42-470/47 H174106	000 39-42-520/47 H174176	000 39-42-570/47 H174177	000 39-42-670/47 H174029														
	1	Gehäuse ME41 Housing ME41	1.4404	000 39-45-320/47 H179384	000 39-45-420/47 H179385	000 39-45-470/47 H179386	000 39-45-520/47 H179390	000 39-45-570/47 H179388	000 39-45-670/47 H179389														
	1	Gehäuse ME42 Housing ME42	1.4404	000 39-46-320/47 H179397	000 39-46-420/47 H179398	000 39-46-470/47 H179400	000 39-46-520/47 H179401	000 39-46-570/47 H179402	000 39-46-670/47 H179404														
	1	Gehäuse ME43 Housing ME43	1.4404	000 39-47-320/47 H179426	000 39-47-420/47 H179427	000 39-47-470/47 H179428	000 39-47-520/47 H179429	000 39-47-570/47 H179430	000 39-47-670/47 H179431														
	1	Gehäuse ME44 Housing ME44	1.4404	000 39-48-320/47 H179432	000 39-48-420/47 H179433	000 39-48-470/47 H176701	000 39-48-520/47 H179434	000 39-48-570/47 H179435	000 39-48-670/47 H179436														
	1	Gehäuse M41 Housing M41	1.4404	000 39-41-320/43	000 39-41-420/43 H202001	000 39-41-470/43 H201026	000 39-41-520/43 H204816	000 39-41-570/43 H201179	000 39-41-670/43														
	1	Gehäuse M42 Housing M42	1.4404	000 39-42-320/43	000 39-42-420/43 H202002	000 39-42-470/43 H201027	000 39-42-520/43	000 39-42-570/43 H201028	000 39-42-670/43														
	1	Gehäuse ME41 Housing ME41	1.4404	000 39-45-320/43	000 39-45-420/43	000 39-45-470/43 H201037	000 39-45-520/43	000 39-45-570/43	000 39-45-670/43														
	1	Gehäuse ME42 Housing ME42	1.4404	000 39-46-320/43	000 39-46-420/43	000 39-46-470/43 H201036	000 39-46-520/43	000 39-46-570/43	000 39-46-670/43														
	1	Gehäuse ME43 Housing ME43	1.4404	000 39-47-320/43	000 39-47-420/43 H204815	000 39-47-470/43	000 39-47-520/43	000 39-47-570/43	000 39-47-670/43														
	1	Gehäuse ME44 Housing ME44	1.4404	000 39-48-320/43	000 39-48-420/43 H201998	000 39-48-470/43 H201035	000 39-48-520/43	000 39-48-570/43 H201038	000 39-48-670/43														
	1	Gehäuse MT41 Housing MT41	1.4404	000 39-43-320/47 H175706	000 39-43-420/47 H175718	000 39-43-470/47 H175720	000 39-43-520/47 H175722	000 39-43-570/47 H175724	000 39-43-670/47 H175726														
	1	Gehäuse MT42 Housing MT42	1.4404	000 39-44-320/47 H175707	000 39-44-420/47 H175719	000 39-44-470/47 H175720	000 39-44-520/47 H175722	000 39-44-570/43 H201066	000 39-44-670/43														
	1	Gehäuse MT41 Housing MT41	1.4404	000 39-43-320/43	000 39-43-420/43	000 39-43-470/43	000 39-43-520/43	000 39-43-570/43	000 39-43-670/43														
	1	Gehäuse MT42 Housing MT42	1.4404	000 39-44-320/43	000 39-44-420/43	000 39-44-470/43	000 39-44-520/43	000 39-44-570/43	000 39-44-670/43														

Datum: 28.06.07 09.03.12 26.09.14 10.06.16
Name: Trytko Trytko Trytko
Geprüft: Schulz Schulz Schulz

Datum: Blatt 2 von 6
Name: RN 01.064.9-1
Geprüft:



Weitergabe sowie Vervielfältigung dieser Unterlage, Verwertung und Mitteilung ihres Inhalts nicht gestattet, soweit nicht schriftlich zugestanden. Verstößt verpflichtet zum Schadensersatz und kann strafrechtliche Folgen haben (Paragraf 18 UWG, Paragraf 106 UrtG). Eigentum und alle Rechte, auch für Patenterteilung und Gebrauchsmustererteilung, vorbehalten. SPX FLOW, Germany

Ersatzteilliste: spare parts list

Membranventil fan support MS4, MSE4, MST4 FS-CU und VSM Diaphragm valve fan support MS4, MSE4, MST4 FS-CU and PSH 1-4 Zoll / inch

pos. item	Menge quantity	Beschreibung description	Material	1"	1,5"	2"	2,5"	3"	4"
				WS-Nr. ref.-no.	WS-Nr. ref.-no.	WS-Nr. ref.-no.	WS-Nr. ref.-no.	WS-Nr. ref.-no.	WS-Nr. ref.-no.
14		Skt. Schraube Hex. Screw DIN EN 24017-A2-70	1.4301	65-01-055/13 4xM6x12 H78750		65-01-081/15 4xM8x16 H78772			65-01-130/15 8xM10x16 H78806
15	1	O-Ring gültig bis Mai 2009 valid until May 2009	EPDM	58-06-154/64 35x2,5 H320272	58-06-277/64 60x3 H320262	58-06-347/64 76x3,5 H319391	58-06-580/64 120x3,5 H320274		
15.1	1	O-Ring gültig ab Mai 2009 valid from May 2009	EPDM	58-06-144/64 35x3,5 H324909	58-06-269/64 60x4 H324910	58-06-340/64 75x4,5 H324911	58-06-581/64 120x4,5 H324913		
16	1	O-Ring	EPDM	58-06-038/64 11x2,5 H320269	58-06-067/64 18x3 H320261	58-06-083/64 22x3,5 H319390	58-06-140/64 31,1x3,5 H320271		
17	1	Steuerkopf Actuator Ausführung matt-gl. design satin fin.	1.4301	15-32-050/17 H171378	15-32-051/17 H171379	15-32-052/17 H171380			
	1	Steuerkopf Actuator Ausführung poliert design polished	1.4301	15-32-050/13 H178155	15-32-051/13 H177400	15-32-052/13 H200827			
18									
19									
20	1	O-Ring OR 66x2	NBR 70-75 Shore A		58-06-297/83 H173930				
21	1	Zentrierscheibe Centering nut	1.4301		15-28-940/12 H170196				
22	1	Skt. Mutter Hex. Nut DIN EN ISO 10511 M12-A2	1.4301		65-50-105/15 H112376				
23	1	Schaltnocke Operating cam	1.4523	08-52-290/97 H173086		08-52-291/97 H173087			
24	1	VSM Gehäuse Proximity switch holder housing	Vestamid		15-33-932/93 H173931				
25	4	Skt. Schraube Hex. Screw DIN EN 24017 M8x16 -A2-70	1.4301		65-01-081/15 H78772				
26	1	Control-Unit CU41-S-Direckt Connect	PA 6.6 GF 30 schwarz		08-45-100/93 H320460				
27	1	CU4-S-Adapter	PA 6.6 GF 30 schwarz		08-48-600/93 H320474				

Datum:	28.06.07	09.03.12	26.09.14	10.06.16
Name:	Trytko	Trytko	Trytko	Trytko
Geprüft:	Schulz	Schulz		

Datum:				
Name:				
Geprüft:				

Blatt	4	von	6
RN 01.064.9-1			



Ersatzteilliste: spare parts list

**Membranventil fan support MS4, MSE4, MST4 FS-CU und VSM
Diaphragm valve fan support MS4, MSE4, MSE4, MST4 FS-CU and PSH
1-4 Zoll / inch**

Datum:	28.06.07	09.03.12	26.09.14	10.06.16
Name:	Trytko	Trytko	Trytko	Trytko
Geprüft:	Schulz	Schulz		



Datum:					
Name:					
Geprüft:					

Blatt	5	von	6
RN 01.064.9-1			

pos. item	Menge quantity	Beschreibung description	Material	1"	1,5"	2"	2,5"	3"	4"
				WS-Nr. ref.-no.	WS-Nr. ref.-no.	WS-Nr. ref.-no.	WS-Nr. ref.-no.	WS-Nr. ref.-no.	WS-Nr. ref.-no.
1		Gehäusedichtung Housing seal	EPDM FDA-konform	58-33-392/93 H77464	58-33-442/93 H77488	58-33-492/93 H77512	58-33-542/93 H77543		
28	1	Gehäusedichtung Housing seal	FPM FDA-konform	58-33-392/73 H77463	58-33-442/73 H77487	58-33-492/73 H77511	58-33-542/73 H77542		
	1	Gehäusedichtung Housing seal	HNBR FDA-konform	58-33-392/33 H170018	58-33-442/33 H168714	58-33-492/33 H168759	58-33-542/33 H170075		
29	4	Skt. Schraube Hex. screw	1.4301	65-01-079/15 M8x14 H78768	65-01-079/15 M8x14 H78768	65-01-129/15 M10x14 H78805			

Dichtungssatz **MS4, MSE4 Standardausführung** / seal kit **MS4, MSE4 standard design** gültig bis Mai 2009 / valid until May 2009
 Pos. 2, 5, 11, 13, 15, 16, 22 nur im kompletten Dichtungssatz erhältlich / Item 2, 5, 11, 13, 15, 16, 22 available es complete seal kits only

1	Dichtungssatz Seal kit	TFM / FPM	58-36-780/00 H328328	58-36-781/00 H324515	58-36-782/00	58-36-783/00 H324514	58-36-786/00	58-36-785/00
1	Dichtungssatz Seal kit	TFM / EPDM	58-36-780/01 H322888	58-36-781/01 H322889	58-36-782/01 H322890	58-36-783/01 H322891	58-36-786/01 H322894	58-36-785/01 H322893
1	Dichtungssatz Seal kit	TFM / VMQ	58-36-780/02	58-36-781/02	58-36-782/02	58-36-783/02	58-36-786/02	58-36-785/02
1	Dichtungssatz Seal kit	TFM / HNBR	58-36-780/06 H332211	58-36-781/06	58-36-782/06 H327691	58-36-783/06	58-36-786/06	58-36-785/06

Ersatzteilliste: spare parts list

Membranventil fan support MS4, MSE4, MST4 FS-CU und VSM Diaphragm valve fan support MS4, MSE4, MST4 FS-CU and PSH 1-4 Zoll / inch

Datum:	28.06.07	09.03.12	26.09.14	10.06.16
Name:	Trytko	Trytko	Trytko	Trytko
Geprüft:	Schulz	Schulz		

Datum:				
Name:				
Geprüft:				

Blatt	6	von	6
RN 01.064.9-1			



pos. item	Menge quantity	Beschreibung description	Material	1"	1,5"	2"	2,5"	3"	4"
				WS-Nr. ref.-no.	WS-Nr. ref.-no.	WS-Nr. ref.-no.	WS-Nr. ref.-no.	WS-Nr. ref.-no.	WS-Nr. ref.-no.
Dichtungssatz MS4, MSE4 Standardausführung / seal kit MS4, MSE4 standard design Pos. 2, 5, 11, 13, 15.1, 16, 22 nur im kompletten Dichtungssatz erhältlich / Item 2, 5, 11, 13, 15.1, 16, 22 available es complete seal kits only									
1		Dichtungssatz Seal kit	TFM / FPM	58-36-920/00 H331957	58-36-921/00 H331957	58-36-922/00 H329916	58-36-923/00 H329273	58-36-926/00	58-32-925/00
1		Dichtungssatz Seal kit	TFM / EPDM	58-36-920/01 H324944	58-36-921/01 H324945	58-36-922/01 H324946	58-36-923/01 H324947	58-36-926/01 H324950	58-36-925/01 H324949
1		Dichtungssatz Seal kit	TFM / VMQ	58-36-920/02	58-36-921/02	58-36-922/02	58-36-923/02	58-36-926/02	58-36-925/02
1		Dichtungssatz Seal kit	TFM / HNBR	58-36-920/06 H329966	58-36-921/06 H329274	58-36-922/06 H328730	58-36-923/06 H329272	58-36-926/06	58-36-925/06 H329967
Dichtungssatz MST4 Standardausführung / seal kit MST4 standard design Pos. 2, 5, 11, 13, 15.1, 16, 22, 28 nur im kompletten Dichtungssatz erhältlich / Item 2, 5, 11, 13, 15.1, 16, 22, 28 available es complete seal kits only									
1		Dichtungssatz Seal kit	TFM / FPM	58-36-941/00	58-36-942/00	58-36-943/00	58-36-944/00	58-36-947/00	58-32-946/00
1		Dichtungssatz Seal kit	TFM / EPDM	58-36-941/01	58-36-942/01	58-36-943/01	58-36-944/01	58-36-947/01	58-36-946/01
1		Dichtungssatz Seal kit	TFM / VMQ	58-36-941/02	58-36-942/02	58-36-943/02	58-36-944/02	58-36-947/02	58-36-946/02
1		Dichtungssatz Seal kit	TFM / HNBR	58-36-941/06	58-36-942/06	58-36-943/06	58-36-944/06	58-36-947/06	58-36-946/06

Weitergabe sowie Vervielfältigung dieser Unterlage, Verwertung und Mitteilung ihres Inhalts nicht gestattet, soweit nicht schriftlich zugestanden. Verstößt verpflichtet zum Schadensersatz und kann strafrechtliche Folgen haben (Paragraf 18 UWG, Paragraf 106 UrhG). Eigentum und alle Rechte, auch für Patenterteilung und Gebrauchsmustereintragung, vorbehalten. SPX FLOW, Germany

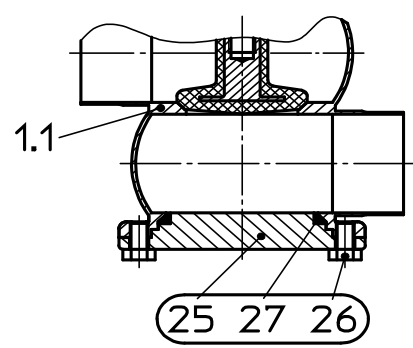
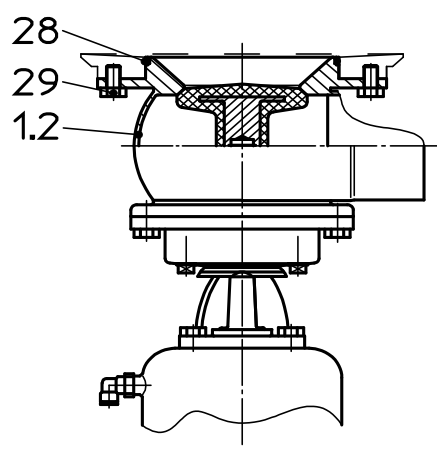
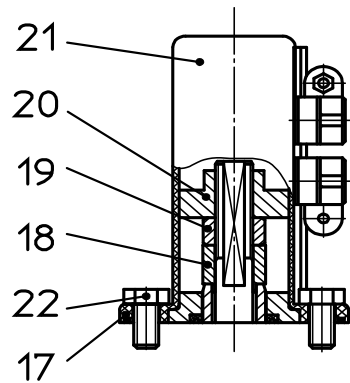
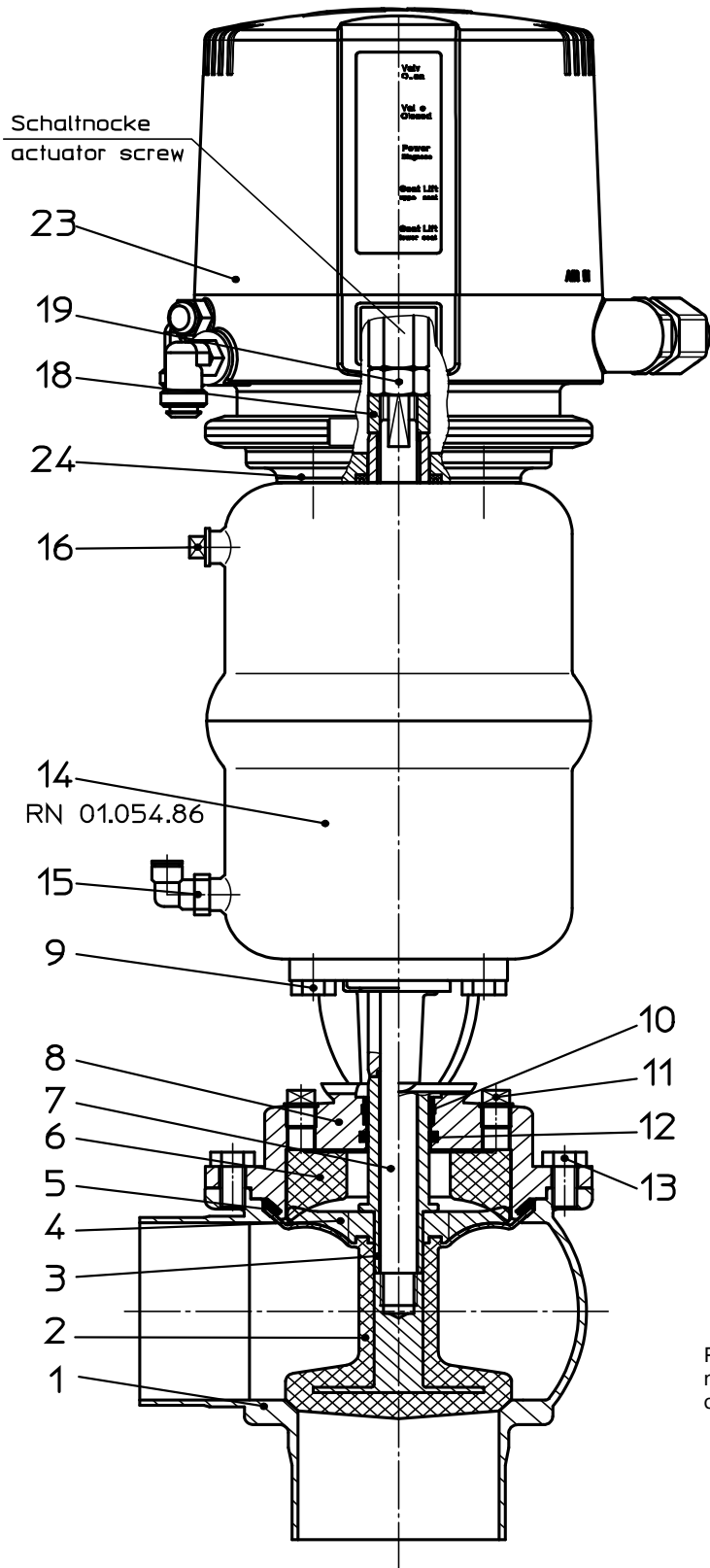

Pos. 25, 26, 27 / item. 25, 26, 27
 nur für Nennweiten DN65, 80, 100 3A-Ausführung
 only for sizes DN65, 80, 100 3A-design

Pos. 15 und 16 nur bei Steuerkopf 3A-Ausführung
 item. 15 and 16 only for actuator 3A-design

Datum:	25.05.09	02.04.12	25.09.14	10.06.16						
Name:	Trytko	Trytko	Trytko	Trytko						
Geprüft:	Schulz	Schulz								

Ersatzteilliste: spare parts list

Membranventil fan support MSP4, MSEP4, MSTP4 FS-CU und VSM
Diaphragm valve fan support MSP4, MSEP, MSTP4 FS-CU and PSH
DN 25-100



APV

SPX FLOW
 Germany

Blatt 1 von 7

RN 01.064.10

Ersatzteilliste: spare parts list

**Membranventil fan support MSP4, MSEP4, MSTP4 FS-CU und VSM
Diaphragm valve fan support MSP4, MSEP4, MSTP4 FS-CU and PSH
DN25-100**

Datum:		25.05.09	02.04.12	25.09.14	10.06.16
Name:	Trytko	Trytko	Trytko	Trytko	Trytko
Geprüft:	Schulz	Schulz			
Datum:					
Name:					
Geprüft:					
		Blatt 3 von 7		RN 01.064.10	

pos. item	Menge quantity	Beschreibung description	Material	DN25	DN40	DN50	DN65	DN80	DN100
				WS-Nr. ref.-no.	WS-Nr. ref.-no.	WS-Nr. ref.-no.	WS-Nr. ref.-no.	WS-Nr. ref.-no.	WS-Nr. ref.-no.
1	1	Gehäuse M41 Housing M41	1.4404	000 39-41-295/43	000 39-41-395/43	000 39-41-445/43	000 39-41-495/43	000 39-41-545/43	000 39-41-645/43
	1	Gehäuse M42 Housing M42	1.4404	000 39-42-295/43	000 39-42-395/43	000 39-42-445/43	000 39-42-495/43	000 39-42-545/43	000 39-42-645/43
	1	Gehäuse M41 Housing M41	1.4404	3A0 39-41-295/43 H320478	3A0 39-41-395/43 H320285	3A0 39-41-445/43 H320305	3A0 39-41-495/43 H320140	3A0 39-41-545/43 H320327	3A0 39-41-645/43 H320384
	1	Gehäuse M42 Housing M42	1.4404	3A0 39-42-295/43	3A0 39-42-395/43	3A0 39-42-445/43	3A0 39-42-495/43	3A0 39-42-545/43	3A0 39-42-645/43
1.1	1	Gehäuse ME41 Housing ME41	1.4404	000 39-45-295/43	000 39-45-395/43	000 39-45-445/43	000 39-45-495/43	000 39-45-545/43	000 39-45-645/43
	1	Gehäuse ME42 Housing ME42	1.4404	000 39-46-295/43	000 39-46-395/43	000 39-46-445/43	000 39-46-495/43	000 39-46-545/43	000 39-46-645/43
	1	Gehäuse ME43 Housing ME43	1.4404	000 39-47-295/43	000 39-47-395/43	000 39-47-445/43	000 39-47-495/43	000 39-47-545/43	000 39-47-645/43
	1	Gehäuse ME44 Housing ME44	1.4404	000 39-48-295/43	000 39-48-395/43	000 39-48-445/43	000 39-48-495/43	000 39-48-545/43	000 39-48-645/43
	1	Gehäuse ME41 Housing ME41	1.4404	3A0 39-45-295/43	3A0 39-45-395/43	3A0 39-45-445/43	3A0 39-45-495/43	3A0 39-45-545/43	3A0 39-45-645/43
	1	Gehäuse ME42 Housing ME42	1.4404	3A0 39-46-295/43	3A0 39-46-395/43	3A0 39-46-445/43	3A0 39-46-495/43	3A0 39-46-545/43	3A0 39-46-645/43
	1	Gehäuse ME43 Housing ME43	1.4404	3A0 39-47-295/43	3A0 39-47-395/43	3A0 39-47-445/43	3A0 39-47-495/43	3A0 39-47-545/43	3A0 39-47-645/43
	1	Gehäuse ME44 Housing ME44	1.4404	3A0 39-48-295/43	3A0 39-48-395/43	3A0 39-48-445/43	3A0 39-48-495/43	3A0 39-48-545/43	3A0 39-48-645/43
1.2	1	Gehäuse MT41 Housing MT41	1.4404	000 39-43-295/43	000 39-43-395/43	000 39-43-445/43	000 39-43-495/43	000 39-43-545/43	000 39-43-645/43
	1	Gehäuse MT42 Housing MT2	1.4404	000 39-44-295/43	000 39-44-395/43	000 39-44-445/43	000 39-44-495/43	000 39-44-545/43	000 39-44-645/43
	1	Gehäuse MT41 Housing MT41	1.4404	3A0 39-43-295/43	3A0 39-43-395/43	3A0 39-43-445/43	3A0 39-43-495/43	3A0 39-43-545/43	3A0 39-43-645/43
	1	Gehäuse MT42 Housing MT42	1.4404	3A0 39-44-295/43	3A0 39-44-395/43	3A0 39-44-445/43	3A0 39-44-495/43	3A0 39-44-545/43	3A0 39-44-645/43



Weitergabe sowie Vervielfältigung dieser Unterlage, Verwertung und Mitteilung ihres Inhalts nicht gestattet, soweit nicht schriftlich zugestanden. Verstoß verpflichtet zum Schadensersatz und kann strafrechtliche Folgen haben (Paragraf 18 UWG, Paragraf 106 UrnG). Eigentum und alle Rechte, auch für Patenterteilung und Gebrauchsmustererteilung, vorbehalten. SPX FLOW, Germany

Ersatzteilliste: spare parts list

Membranventil fan support MSP4, MSEP4, MSTP4 FS-CU und VSM Diaphragm valve fan support MSP4, MSEP4, MSTP4 FS-CU and PSH DN25-100

pos. item	Menge quantity	Beschreibung description	Material	DN25	DN40	DN50	DN65	DN80	DN100
				WS-Nr. ref.-no.	WS-Nr. ref.-no.	WS-Nr. ref.-no.	WS-Nr. ref.-no.	WS-Nr. ref.-no.	WS-Nr. ref.-no.
2	1	Membranschaft Diaphragm shaft	TFM 1705 FDA-konform	39-22-299/22 H321019	39-22-399/22 H321020	39-22-449/22 H321021	39-22-499/22 H321022	39-22-549/22 H321023	39-22-649/22 H321024
3	1	Schaft oben Upper valve shaft	1.4301	39-22-070/12 H318486	39-22-071/12 H318487	39-22-072/12 H318488	39-22-072/12 H318488	39-22-073/12 H318489	39-22-074/12 H318490
4	1	Stern Star	1.4301	08-48-520/12 H320414	08-48-521/12 H320249	08-48-521/12 H319397	08-48-522/12 H319397	08-48-523/12 H320316	08-48-524/12 H320332
5	1	O-Ring O-ring	EPDM FDA-konform	58-06-144/64 35x3,5 H324909	58-06-269/64 60x4 H324910	58-06-340/64 75x4,5 H324911	58-06-488/64 95x4,5 H324912	58-06-488/64 120x4,5 H324913	58-06-581/64 120x4,5 H324913
6	1	Membranunterstützung Fan support	Ryton R4-XT	08-48-510/93 H318532	08-48-511/93 H318533	08-48-512/93 H318534	08-48-512/93 H318534	08-48-513/93 H318535	08-48-514/93 H318536
7	1	Zugstange Guide rod	1.4305	39-23-080/12 H202599	39-23-129/12 H320621	39-23-129/12 H320621	39-23-083/12 H202608	39-23-130/12 H320577	39-23-130/12 H320577
8	1	Laterne Ausführung matt-gl. design satin fin.	1.4404	000 39-40-040/47 H318491	000 39-40-041/47 H318492	000 39-40-041/47 H318492	000 39-40-042/47 H318493	000 39-40-043/47 H318494	000 39-40-044/47 H320578
	1	Laterne Ausführung poliert design polished	1.4404	000 39-40-040/43	000 39-40-041/43	000 39-40-041/43	000 39-40-042/43	000 39-40-043/43	000 39-40-044/43
9	1	Laterne Ausführung 3A-blank design 3A-bright fin.	1.4404	3A0 39-40-040/43 H320458	3A0 39-40-041/43 H320355	3A0 39-40-041/43 H320355	3A0 39-40-042/43 H319373	3A0 39-40-043/43 H320320	3A0 39-40-044/43 H318495
	4	Skt. Schraube Hex. Screw	1.4301	DIN EN 24017-A2-70	65-01-081/15 M8x16 H78772	65-01-081/15 M8x16 H78772	65-01-081/15 M8x20 H78776	65-01-083/15 M8x20 H78776	65-01-083/15 M8x20 H78776
10	1	Führungsbuchse Standardausführung standard design	PTFE 25% Kohle	08-01-177/23 H162714	08-01-177/23 H162714	08-01-178/23 H207154	08-01-178/23 H207154	08-01-178/23 H207154	08-01-178/23 H207154
	1	Führungsbuchse Ausführung -3A design -3A	KETRON PEEK	08-01-177/23 H162714	08-01-177/23 H162714	08-01-177/23 H162714	3A0 08-01-178/27 H315800	3A0 08-01-178/27 H315800	3A0 08-01-178/27 H315800
11	2	Entlüftungsstopfen Venting plug	PHT/BLACK	08-60-005/94 H175308	08-60-005/94 H175308	08-60-005/94 H175308	08-60-005/94 H175308	08-60-005/94 H175308	08-60-005/94 H175308
12	1	O-Ring	EPDM	58-06-052/64 15,3x2,4 H206007	58-06-052/64 15,3x2,4 H206007	58-06-052/64 15,3x2,4 H206007	58-06-078/64 20,2x3 H121794	58-06-078/64 20,2x3 H121794	58-06-078/64 20,2x3 H121794
	1	O-Ring	FDA-konform	65-01-055/13 4xM6x12 H78750	65-01-055/13 4xM8x16 H78772	65-01-055/13 4xM8x16 H78772	65-01-081/15 8xM10x16 H78806	65-01-081/15 8xM10x16 H78806	65-01-130/15 8xM10x16 H78806
13	1	Skt. Schraube Hex. Screw	1.4301	000 15-32-050/17 H171378	000 15-32-051/17 H171379	000 15-32-051/17 H171379	000 15-32-051/17 H171379	000 15-32-052/17 H171380	000 15-32-052/17 H171380
14	1	Steuerkopf Actuator	1.4301	000 15-32-050/17 H171378	000 15-32-051/17 H171379	000 15-32-051/17 H171379	000 15-32-051/17 H171379	000 15-32-052/17 H171380	000 15-32-052/17 H171380



Blatt 4 von 7
RN 01.064.10

Weitergabe sowie Vervielfältigung dieser Unterlage, Verwertung und Mitteilung ihres Inhalts nicht gestattet, soweit nicht schriftlich zugestanden. Verstoß verpflichtet zum Schadenersatz und kann strafrechtliche Folgen haben (Paragraf 18 UWVG, Paragraf 106 UrhG). Eigentum und alle Rechte, auch für Patenterteilung und Gebrauchsmustererteilung, vorbehalten. SPX FLOW, Germany

Ersatzteilliste: spare parts list

Membranventil fan support MSP4, MSEP4, MSTP4 FS-CU und VSM Diaphragm valve fan support MSP4, MSEP4, MSTP4 FS-CU and PSH DN25-100

pos. item	Menge quantity	Beschreibung description	Material	DN25	DN40	DN50	Datum:			APV			
							WS-Nr. ref.-no.	WS-Nr. ref.-no.	WS-Nr. ref.-no.	Trytko	Trytko	Trytko	Blatt
14	1	Steuerkopf Actuator	1.4301	000 15-32-050/13 H178155	000 15-32-051/13 H177400	DN50	DN65	DN80	DN100	02.04.12	25.09.14	10.06.16	RN 01.064.10
	1	Steuerkopf Actuator	1.4301	3A0 15-32-059/13 H208693	3A0 15-32-060/13 H173538	WS-Nr. ref.-no.	WS-Nr. ref.-no.	WS-Nr. ref.-no.	WS-Nr. ref.-no.	000 15-32-052/13 H200827	3A0 15-32-061/13 H173524		
15	1	W-Verschr. schwenk. W-Union slewable	PA-1.4301							08-60-811/93 H312732			
16	1	Entlüftungsstopfen Venting plug	PE-HARD YELLOW							08-60-005/93 H16218			
17	1	O-Ring O-ring	NBR 70-75 Shore A							58-06-297/83 H173930			
18	1	Zentrierscheibe Centering nut	1.4301							15-28-940/12 H170196			
19	1	Skt. Mutter Hex. Nut	1.4301							65-50-105/15 H112376			
20	1	Schaltnocke Operating cam	1.4523	08-52-290/97 H173086						08-52-291/97 H173087			
21	1	VSM Gehäuse Proximity switch holder housing	Vestamid							15-33-932/93 H173931			
22	4	Skt. Schraube Hex. Screw	1.4301							65-01-081/15 H78772			
23	1	Control-Unit Control-Unit	PA 6.6 GF 30 schwarz							08-45-100/93 H320460			
24	1	CU4-S-Adapter CU4-S-adapter	PA 6.6 GF 30 schwarz							08-48-600/93 H320474			
25	1	Gehäusedeckel Housing lid	1.4404							000 39-01-139/47 H107248	000 39-01-140/47 H68671	000 39-01-143/47 H107251	
	1	Gehäusedeckel Housing lid	1.4404							3A0 39-01-233/43 H208478			
26	1	Skt. Schraube Hex. Screw	1.4301							65-01-081/15 4xM8x16 H78772			65-01-130/15 8xM10x16 H78806
	1	O-Ring O-ring	EPDM FDA-konform							58-06-345/64 75.6x5.33 H204241	58-06-496/64 101x5.33 H204242	58-06-520/64 119,2x5,7 H204243	

Weitergabe sowie Vervielfältigung dieser Unterlage, Verwertung und Mitteilung ihres Inhalts nicht gestattet, soweit nicht schriftlich zugestanden. Verstoß verpflichtet zum Schadenersatz und kann strafrechtliche Folgen haben (Paragraf 18 UWVG, Paragraf 106 UrhG). Eigentum und alle Rechte, auch für Patenterteilung und Gebrauchsmusterantragung, vorbehalten. SPX FLOW, Germany

Ersatzteilliste: spare parts list

Membranventil fan support MSP4, MSEP4, MSTP4 FS-CU und VSM Diaphragm valve fan support MSP4, MSEP4, MSTP4 FS-CU and PSH DN25-100

pos. item	Menge quantity	Beschreibung description	Material	DN25	DN40	DN50	DN65	DN80	DN100	Datum: 25.05.09				10.06.16		
										WS-Nr. ref.-no.	WS-Nr. ref.-no.	WS-Nr. ref.-no.	WS-Nr. ref.-no.	Trytko Schulz	Trytko Schulz	Trytko Schulz
	1	O-Ring O-ring	FPM FDA-konform				58-06-345/73 75,6x5,33 H320762	58-06-496/73 101x5,33	58-06-520/73 119,2x5,7							
27	1	O-Ring O-ring	HNBR FDA-konform				58-06-345/33 75,6x5,33 H310656	58-06-496/33 101x5,33 H310657	58-06-520/33 119,2x5,7 H310658							
	1	O-Ring O-ring	VMQ FDA-konform				58-06-345/53 75,6x5,33	58-06-496/53 101x5,33	58-06-520/53 119,2x5,7							
	1	Gehäusedichtung Housing seal	EPDM FDA-konform	58-33-392/93 H77464	58-33-442/93 H77488	58-33-492/93 H77512	58-33-542/93 H77543	58-33-642/93 H77583	58-33-692/93 H77608							
28	1	Gehäusedichtung Housing seal	FPM FDA-konform	58-33-392/73 H77463	58-33-442/73 H77487	58-33-492/73 H77511	58-33-542/73 H77542	58-33-642/73 H77582	58-33-692/73 H77607							
	1	Gehäusedichtung Housing seal	HNBR FDA-konform	58-33-392/33 H170018	58-33-442/33 H168714	58-33-492/33 H168759	58-33-542/33 H170075	58-33-642/33 H170074	58-33-692/33 H172125							
29	4	Skt. Schraube Hex. Screw	1.4301	65-01-079/15 M8x14 H78768	65-01-079/15 M8x14 H78768	65-01-129/15 M10x14 H78805										
	1	Dichtungssatz Seal kit	PTFE	58-36-790/03 H328455	58-36-791/03 H328456	58-36-792/03 H328457	58-36-793/03 H328458	58-36-794/03 H328459	58-36-795/03 H328460							
	1	Dichtungssatz Seal kit	PTFE / FPM	3A0 58-36-790/00	3A0 58-36-791/00	3A0 58-36-792/00	3A0 58-36-839/00	3A0 58-36-840/00	3A0 58-36-841/00							
	1	Dichtungssatz Seal kit	PTFE / EPDM	3A0 58-36-790/01	3A0 58-36-791/01	3A0 58-36-792/01	3A0 58-36-839/01	3A0 58-36-840/01	3A0 58-36-841/01							
	1	Dichtungssatz Seal kit	PTFE / VMQ	3A0 58-36-790/02	3A0 58-36-791/02	3A0 58-36-792/02	3A0 58-36-839/02	3A0 58-36-840/02	3A0 58-36-841/02							
	1	Dichtungssatz Seal kit	PTFE / HNBR	3A0 58-36-790/06	3A0 58-36-791/06	3A0 58-36-792/06	3A0 58-36-839/06	3A0 58-36-840/06	3A0 58-36-841/06							

Blatt 6 von 7

RN 01.064.10



Weitergabe sowie Vervielfältigung dieser Unterlage, Verwertung und Mitteilung ihres Inhalts nicht gestattet, soweit nicht schriftlich zugestanden. Verstöße verpflichten zum Schadensersatz und kann strafrechtliche Folgen haben (Paragraf 18 UWG, Paragraf 106 UrhG). Eigentum und alle Rechte, auch für Patenterteilung und Gebrauchsmustereintragung, vorbehalten. SPX FLOW, Germany

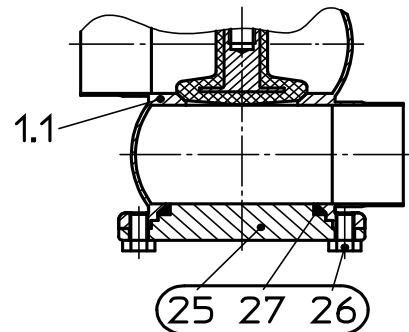
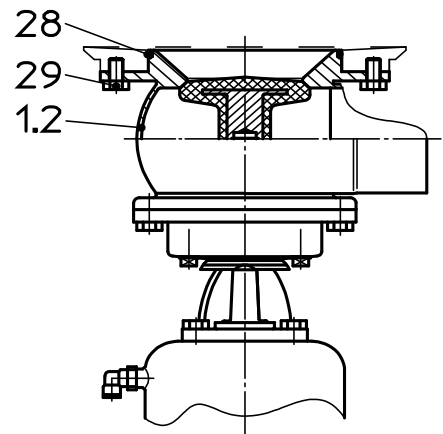
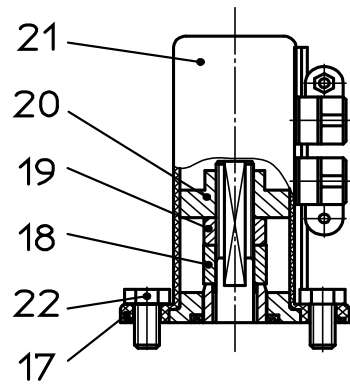
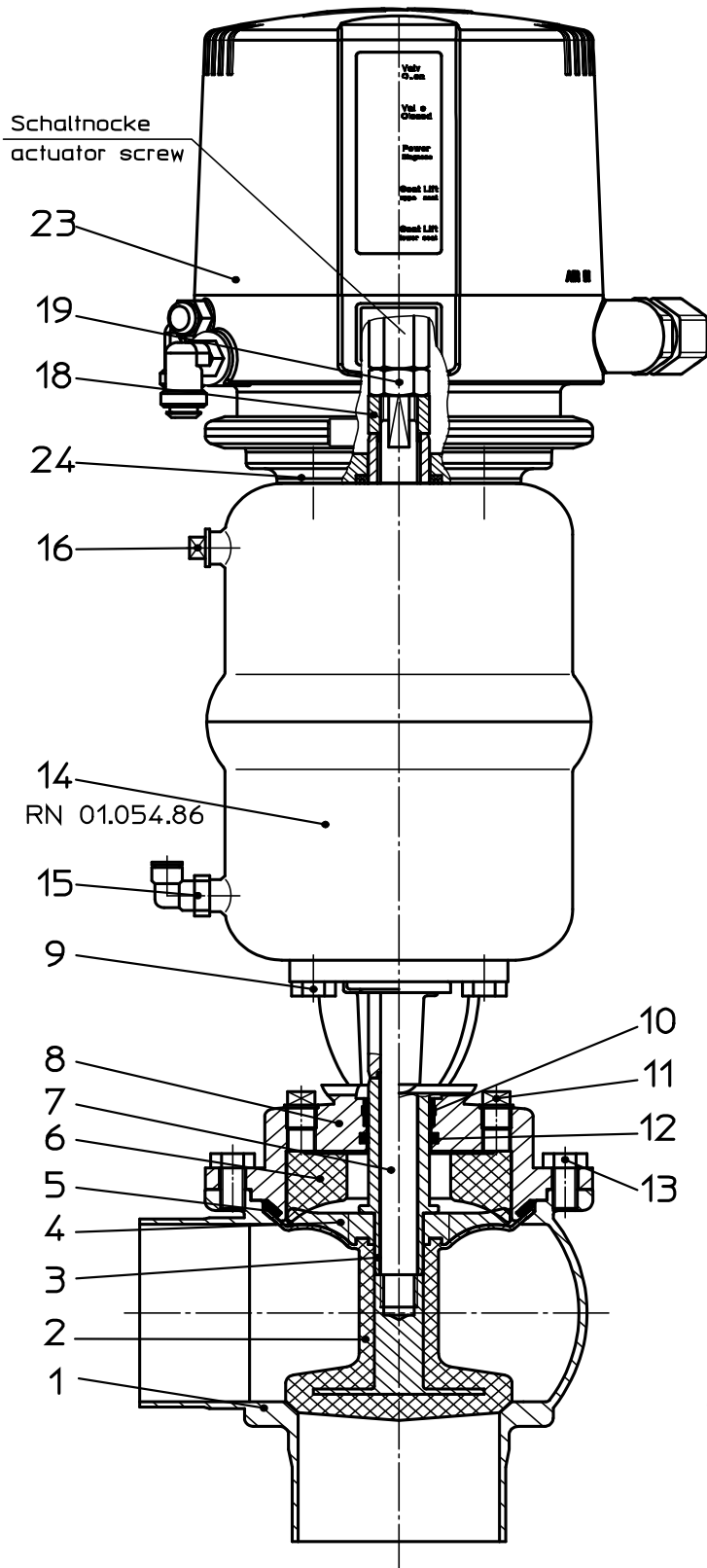

Pos. 25, 26, 27 / item. 25, 26, 27
 nur für Nennweiten 2,5", 3", 4" 3A-Ausführung
 only for sizes 2,5", 3", 4" 3A-design

Pos. 15 und 16 nur bei Steuerkopf 3A-Ausführung
 item. 15 and 16 only for actuator 3A-design



Datum:	25.05.09	02.04.12	25.09.14	10.06.16						
Name:	Trytko	Trytko	Trytko	Trytko						
Geprüft:	Schulz	Schulz								

Ersatzteilliste: spare parts list

Membranventil fan support MSP4, MSEP4, MSTP4 FS-CU und VSM
Diaphragm valve fan support MSP4, MSEP, MSTP4 FS-CU and PSH
 1-4 Zoll / inch



SPX FLOW
 Germany

Blatt 1 von 7

RN 01.064.10-1

Ersatzteilliste: spare parts list

Membranventil fan support MSP4, MSEP4, MSTP4 FS-CU und VSM Diaphragm valve fan support MSP4, MSEP4, MSTP4 FS-CU and PSH 1-4 Zoll / inch

Datum:	25.05.09	02.04.12	25.09.14	10.06.16	
Name:	Trytko	Trytko	Trytko	Trytko	
Geprüft:	Schulz	Schulz			
Blatt 2 von 7					
RN 01.064.10-1					

pos. item	Menge quantity	Beschreibung description	Material	1"		1,5"		2"		2,5"		3"		4"		
				WS-Nr. ref.-no.	WS-Nr. ref.-no.	WS-Nr. ref.-no.	WS-Nr. ref.-no.	WS-Nr. ref.-no.	WS-Nr. ref.-no.	WS-Nr. ref.-no.	WS-Nr. ref.-no.	WS-Nr. ref.-no.	WS-Nr. ref.-no.	WS-Nr. ref.-no.		
1	1	Gehäuse M41 Housing M41	1.4404	000 39-41-320/47 H174026	000 39-41-420/47 H174156	000 39-41-470/47 H174105	000 39-41-520/47 H174173	000 39-41-570/47 H174175	000 39-41-670/47 H174028							
	1	Gehäuse M42 Housing M42	1.4404	000 39-42-320/47 H174132	000 39-42-420/47 H174157	000 39-42-470/47 H174106	000 39-42-520/47 H174176	000 39-42-570/47 H174177	000 39-42-670/47 H174029							
	1	Gehäuse M41 Housing M41	1.4404	3A0 39-41-800/47 H321875	3A0 39-41-801/47 H319773	3A0 39-41-802/47 H321110	3A0 39-41-803/47 H321876	3A0 39-41-804/47 H320166	3A0 39-41-805/47 H321877							
	1	Gehäuse M42 Housing M42	1.4404	3A0 39-42-800/47 H321426	3A0 39-42-801/47 H321109	3A0 39-42-802/47 H321108	3A0 39-42-803/47 H321878	3A0 39-42-804/47 H319774	3A0 39-42-805/47 H321879							
	1	Gehäuse ME41 Housing ME41	1.4404	000 39-45-320/47 H179384	000 39-45-420/47 H179385	000 39-45-470/47 H179386	000 39-45-520/47 H179390	000 39-45-570/47 H179388	000 39-45-670/47 H179389							
	1	Gehäuse ME42 Housing ME42	1.4404	000 39-46-320/47 H179397	000 39-46-420/47 H179398	000 39-46-470/47 H179400	000 39-46-520/47 H179401	000 39-46-570/47 H179402	000 39-46-670/47 H179404							
	1	Gehäuse ME43 Housing ME43	1.4404	000 39-47-320/47 H179426	000 39-47-420/47 H179427	000 39-47-470/47 H179428	000 39-47-520/47 H179429	000 39-47-570/47 H179430	000 39-47-670/47 H179431							
	1	Gehäuse ME44 Housing ME44	1.4404	000 39-48-320/47 H179432	000 39-48-420/47 H179433	000 39-48-470/47 H176701	000 39-48-520/47 H179434	000 39-48-570/47 H179435	000 39-48-670/47 H179436							
	1.1	1	Gehäuse ME41 Housing ME41	1.4404	3A0 39-45-320/47 H326064	3A0 39-45-420/47 H326064	3A0 39-45-470/47 H321107	3A0 39-45-520/47	3A0 39-45-570/47	3A0 39-45-670/47						
	1	1	Gehäuse ME42 Housing ME42	1.4404	3A0 39-46-320/47	3A0 39-46-420/47	3A0 39-46-470/47	3A0 39-46-520/47	3A0 39-46-570/47	3A0 39-46-670/47						
	1	1	Gehäuse ME43 Housing ME43	1.4404	3A0 39-47-320/47	3A0 39-47-420/47	3A0 39-47-470/47	3A0 39-47-520/47	3A0 39-47-570/47	3A0 39-47-670/47						
	1	1	Gehäuse ME44 Housing ME44	1.4404	3A0 39-48-320/47	3A0 39-48-420/47	3A0 39-48-470/47	3A0 39-48-520/47	3A0 39-48-570/47	3A0 39-48-670/47						
1.2	1	Gehäuse ME41 Housing ME41	1.4404	000 39-45-320/47 H326064	000 39-45-420/47 H326064	000 39-45-470/47 H321107	000 39-45-520/47	000 39-45-570/47	000 39-45-670/47							
	1	Gehäuse ME42 Housing ME42	1.4404	3A0 39-46-320/47	3A0 39-46-420/47	3A0 39-46-470/47	3A0 39-46-520/47	3A0 39-46-570/47	3A0 39-46-670/47							
	1	Gehäuse ME43 Housing ME43	1.4404	3A0 39-47-320/47	3A0 39-47-420/47	3A0 39-47-470/47	3A0 39-47-520/47	3A0 39-47-570/47	3A0 39-47-670/47							
	1	Gehäuse ME44 Housing ME44	1.4404	3A0 39-48-320/47	3A0 39-48-420/47	3A0 39-48-470/47	3A0 39-48-520/47	3A0 39-48-570/47	3A0 39-48-670/47							
	1	Gehäuse MT41 Housing MT41	1.4404	000 39-43-320/47 H175706	000 39-43-420/47 H175718	000 39-43-470/47 H175720	000 39-43-520/47 H175722	000 39-43-570/47 H322810	000 39-43-670/47							
	1	Gehäuse MT42 Housing MT42	1.4404	000 39-44-320/47 H175707	000 39-44-420/47 H175719	000 39-44-470/47 H175721	000 39-44-520/47 H175723	000 39-44-570/47 H175724	000 39-44-670/47							
	1	Gehäuse MT41 Housing MT41	1.4404	3A0 39-43-320/47	3A0 39-43-420/47	3A0 39-43-470/47	3A0 39-43-520/47	3A0 39-43-570/47	3A0 39-43-670/47							
	1	Gehäuse MT42 Housing MT42	1.4404	3A0 39-44-320/47	3A0 39-44-420/47	3A0 39-44-470/47	3A0 39-44-520/47	3A0 39-44-570/47	3A0 39-44-670/47							
	1	Gehäuse MT41 Housing MT41	1.4404	000 39-43-320/47 H175706	000 39-43-420/47 H175718	000 39-43-470/47 H175720	000 39-43-520/47 H175722	000 39-43-570/47 H322810	000 39-43-670/47							
	1	Gehäuse MT42 Housing MT42	1.4404	000 39-44-320/47 H175707	000 39-44-420/47 H175719	000 39-44-470/47 H175721	000 39-44-520/47 H175723	000 39-44-570/47 H175724	000 39-44-670/47							
	1	Gehäuse MT41 Housing MT41	1.4404	3A0 39-43-320/47	3A0 39-43-420/47	3A0 39-43-470/47	3A0 39-43-520/47	3A0 39-43-570/47	3A0 39-43-670/47							
	1	Gehäuse MT42 Housing MT42	1.4404	3A0 39-44-320/47	3A0 39-44-420/47	3A0 39-44-470/47	3A0 39-44-520/47	3A0 39-44-570/47	3A0 39-44-670/47							

Ersatzteilliste: spare parts list

**Membranventil fan support MSP4, MSEP4, MSTP4 FS-CU und VSM
Diaphragm valve fan support MSP4, MSEP4, MSTP4 FS-CU and PSH
1-4 Zoll / inch**

Datum:		25.05.09	02.04.12	25.09.14	10.06.16
Name:	Trytko	Trytko	Trytko	Trytko	Trytko
Geprüft:	Schulz	Schulz			
Datum:					
Name:					
Geprüft:					
		Blatt 3 von 7		RN 01.064.10-1	

pos. item	Menge quantity	Beschreibung description	Material	1"		1,5"		2"		2,5"		3"		4"												
				WS-Nr. ref.-no.	WS-Nr. ref.-no.	WS-Nr. ref.-no.	WS-Nr. ref.-no.	WS-Nr. ref.-no.	WS-Nr. ref.-no.	WS-Nr. ref.-no.	WS-Nr. ref.-no.	WS-Nr. ref.-no.	WS-Nr. ref.-no.	WS-Nr. ref.-no.												
1	1	Gehäuse M41 Housing M41	1.4404	000 39-41-320/43 H202001	000 39-41-420/43 H202001	000 39-41-470/43 H201026	000 39-41-520/43 H204816	000 39-41-570/43 H201179	000 39-41-670/43	1.4404	Auf. außen-poliiert design outside-polished	Ausf. außen-poliiert design outside-polished	3A0 39-41-800/43 H205535	3A0 39-41-801/43 H205536	3A0 39-41-802/43 H205537	3A0 39-41-803/43 H205538	3A0 39-41-804/43 H205539	3A0 39-41-805/43 H205540								
	1	Gehäuse M42 Housing M42	1.4404	000 39-42-320/43	000 39-42-420/43 H202002	000 39-42-470/43 H201027	000 39-42-520/43	000 39-42-570/43 H201028	000 39-42-670/43		Auf. außen-poliiert design outside-polished								Auf. außen-poliiert design outside-polished	3A0 39-41-800/43 H205535	3A0 39-41-801/43 H205536	3A0 39-41-802/43 H205537	3A0 39-41-803/43 H205538	3A0 39-41-804/43 H205539	3A0 39-41-805/43 H205540	
	1	Gehäuse M41 Housing M41	1.4404	000 39-41-800/43 H205535	000 39-41-801/43 H205536	000 39-41-802/43 H205537	000 39-41-803/43 H205538	000 39-41-804/43 H205539	000 39-41-805/43 H205540		000 39-41-805/43 H205540								Auf. außen- 3A-Standard design outside -3A-standard	Auf. außen- 3A-Standard design outside -3A-standard	3A0 39-41-800/43 H205535	3A0 39-41-801/43 H205536	3A0 39-41-802/43 H205537	3A0 39-41-803/43 H205538	3A0 39-41-804/43 H205539	3A0 39-41-805/43 H205540
	1	Gehäuse M42 Housing M42	1.4404	000 39-42-800/43 H205545	000 39-42-801/43 H205546	000 39-42-802/43 H205547	000 39-42-803/43 H205548	000 39-42-804/43 H205549	000 39-42-805/43 H205550		000 39-42-805/43 H205550								Auf. außen- 3A-Standard design outside -3A-standard	Auf. außen- 3A-Standard design outside -3A-standard	3A0 39-42-800/43 H205545	3A0 39-42-801/43 H205546	3A0 39-42-802/43 H205547	3A0 39-42-803/43 H205548	3A0 39-42-804/43 H205549	3A0 39-42-805/43 H205550
	1	Gehäuse ME41 Housing ME41	1.4404	000 39-45-320/43	000 39-45-420/43	000 39-45-470/43 H201037	000 39-45-520/43	000 39-45-570/43	000 39-45-670/43		000 39-45-670/43								Auf. außen-poliiert design outside-polished	Auf. außen-poliiert design outside-polished	000 39-45-320/43	000 39-45-420/43	000 39-45-470/43 H201037	000 39-45-520/43	000 39-45-570/43	000 39-45-670/43
	1	Gehäuse ME42 Housing ME42	1.4404	000 39-46-320/43	000 39-46-420/43 H202000	000 39-46-470/43 H201036	000 39-46-520/43	000 39-46-570/43	000 39-46-670/43		000 39-46-670/43								Auf. außen-poliiert design outside-polished	Auf. außen-poliiert design outside-polished	000 39-46-320/43	000 39-46-420/43 H202000	000 39-46-470/43 H201036	000 39-46-520/43	000 39-46-570/43	000 39-46-670/43
	1	Gehäuse ME43 Housing ME43	1.4404	000 39-47-320/43	000 39-47-420/43	000 39-47-470/43 H204815	000 39-47-520/43	000 39-47-570/43	000 39-47-670/43		000 39-47-670/43								Auf. außen-poliiert design outside-polished	Auf. außen-poliiert design outside-polished	000 39-47-320/43	000 39-47-420/43	000 39-47-470/43 H204815	000 39-47-520/43	000 39-47-570/43	000 39-47-670/43
	1	Gehäuse ME44 Housing ME44	1.4404	000 39-48-320/43	000 39-48-420/43 H201998	000 39-48-470/43 H201035	000 39-48-520/43	000 39-48-570/43 H201038	000 39-48-670/43		000 39-48-670/43								Auf. außen-poliiert design outside-polished	Auf. außen-poliiert design outside-polished	000 39-48-320/43	000 39-48-420/43 H201998	000 39-48-470/43 H201035	000 39-48-520/43	000 39-48-570/43 H201038	000 39-48-670/43
	1.1	1	Gehäuse ME41 Housing ME41	1.4404	000 39-45-320/43	000 39-45-420/43 H326101	000 39-45-470/43 H316545	000 39-45-520/43	000 39-45-570/43		000 39-45-670/43								Auf. außen- 3A-Standard design outside -3A-standard	Auf. außen- 3A-Standard design outside -3A-standard	3A0 39-45-320/43	3A0 39-45-420/43 H326101	3A0 39-45-470/43 H316545	3A0 39-45-520/43	3A0 39-45-570/43	3A0 39-45-670/43
	1	1	Gehäuse ME42 Housing ME42	1.4404	000 39-46-320/43	000 39-46-420/43 H323150	000 39-46-470/43 H316545	000 39-46-520/43	000 39-46-570/43		000 39-46-670/43								Auf. außen- 3A-Standard design outside -3A-standard	Auf. außen- 3A-Standard design outside -3A-standard	3A0 39-46-320/43	3A0 39-46-420/43 H323150	3A0 39-46-470/43 H316545	3A0 39-46-520/43	3A0 39-46-570/43	3A0 39-46-670/43
	1	1	Gehäuse ME43 Housing ME43	1.4404	000 39-47-320/43	000 39-47-420/43	000 39-47-470/43	000 39-47-520/43	000 39-47-570/43		000 39-47-670/43								Auf. außen- 3A-Standard design outside -3A-standard	Auf. außen- 3A-Standard design outside -3A-standard	3A0 39-47-320/43	3A0 39-47-420/43	3A0 39-47-470/43	3A0 39-47-520/43	3A0 39-47-570/43	3A0 39-47-670/43
	1.2	1	Gehäuse MT41 Housing MT41	1.4404	000 39-43-320/43	000 39-43-420/43 H327136	000 39-43-470/43	000 39-43-520/43	000 39-43-570/43 H201066		000 39-43-670/43								Auf. außen-poliiert design outside-polished	Auf. außen-poliiert design outside-polished	000 39-43-320/43	000 39-43-420/43 H327136	000 39-43-470/43	000 39-43-520/43	000 39-43-570/43 H201066	000 39-43-670/43
1	1	Gehäuse MT42 Housing MT2	1.4404	000 39-44-320/43	000 39-44-420/43	000 39-44-470/43	000 39-44-520/43	000 39-44-570/43	000 39-44-670/43	Auf. außen-poliiert design outside-polished	Auf. außen-poliiert design outside-polished	000 39-44-320/43	000 39-44-420/43	000 39-44-470/43	000 39-44-520/43	000 39-44-570/43	000 39-44-670/43									
1	1	Gehäuse MT41 Housing MT41	1.4404	000 39-43-320/43	000 39-43-420/43	000 39-43-470/43 H316659	000 39-43-520/43	000 39-43-570/43	000 39-43-670/43	Auf. außen- 3A-Standard design outside -3A-standard	Auf. außen- 3A-Standard design outside -3A-standard	3A0 39-43-320/43	3A0 39-43-420/43	3A0 39-43-470/43 H316659	3A0 39-43-520/43	3A0 39-43-570/43	3A0 39-43-670/43									
1	1	Gehäuse MT42 Housing MT42	1.4404	000 39-44-320/43	000 39-44-420/43	000 39-44-470/43	000 39-44-520/43	000 39-44-570/43	000 39-44-670/43	Auf. außen- 3A-Standard design outside -3A-standard	Auf. außen- 3A-Standard design outside -3A-standard	3A0 39-44-320/43	3A0 39-44-420/43	3A0 39-44-470/43	3A0 39-44-520/43	3A0 39-44-570/43	3A0 39-44-670/43									



Weitergabe sowie Vervielfältigung dieser Unterlage, Verwertung und Mitteilung ihres Inhalts nicht gestattet, soweit nicht schriftlich zugestanden. Verstoß verpflichtet zum Schadensersatz und kann strafrechtliche Folgen haben (Paragraf 18 UWG, Paragraf 106 UrhG). Eigentum und alle Rechte, auch für Patenterteilung und Gebrauchsmustererteilung, vorbehalten. SPX FLOW, Germany

Ersatzteilliste: spare parts list

Membranventil fan support MSP4, MSEP4, MSTP4 FS-CU und VSM Diaphragm valve fan support MSP4, MSEP4, MSTP4 FS-CU and PSH 1-4 Zoll / inch

pos. item	Menge quantity	Beschreibung description	Material	1"		1,5"		2"		2,5"		3"		4"	
				WS-Nr. ref.-no.	WS-Nr. ref.-no.	WS-Nr. ref.-no.	WS-Nr. ref.-no.	WS-Nr. ref.-no.	WS-Nr. ref.-no.	WS-Nr. ref.-no.	WS-Nr. ref.-no.	WS-Nr. ref.-no.	WS-Nr. ref.-no.		
2	1	Membranschaft Diaphragm shaft	TFM 1705 FDA-konform	39-22-324/22 H321025	39-22-424/22 H321026	39-22-474/22 H321027	39-22-524/22 H321028	39-22-574/22 H321029	39-22-674/22 H321030						
3	1	Schaft oben Upper valve shaft	1.4301	39-22-070/12 H318486	39-22-071/12 H318487	39-22-072/12 H318488	39-22-072/12 H318488	39-22-074/12 H318490	39-22-074/12 H318490						
4	1	Stern Star	1.4301	08-48-520/12 H320414	08-48-521/12 H320249	08-48-522/12 H319397	08-48-522/12 H319397	08-48-524/12 H320332	08-48-524/12 H320332						
5	1	O-Ring O-ring	EPDM FDA-konform	58-06-144/64 35x3,5 H324909	58-06-269/64 60x4 H324910	58-06-340/64 75x4,5 H324911	58-06-340/64 75x4,5 H324911	58-06-581/64 120x4,5 H324913	58-06-581/64 120x4,5 H324913						
6	1	Membranunterstützung Fan support	Ryton R4-XT	08-48-510/93 H318532	08-48-511/93 H318533	08-48-512/93 H318534	08-48-512/93 H318534	08-48-514/93 H318536	08-48-514/93 H318536						
7	1	Zugstange Guide rod	1.4305	39-23-080/12 H202599	39-23-129/12 H320621	39-23-083/12 H202608	39-23-083/12 H202608	39-23-130/12 H320577	39-23-130/12 H320577						
8	1	Laterne Yoke	1.4404	000 39-40-040/47 H318491	000 39-40-041/47 H318492	000 39-40-041/43 H320355	000 39-40-042/47 H318493	000 39-40-046/47 H318549	000 39-40-044/47 H320578						
9	4	Laterne Yoke	1.4404	000 39-40-040/43 H320458	000 39-40-041/43 H320355	000 39-40-041/43 H320355	000 39-40-042/43 H319373	000 39-40-046/43 H320178	000 39-40-044/43 H318495						
10	1	Skt. Schraube Hex. Screw	1.4301	DIN EN 24017-A2-70	DIN EN 24017-A2-70	65-01-081/15 M8x16 H78772	65-01-081/15 M8x16 H78772	65-01-083/15 M8x20 H78776	65-01-083/15 M8x20 H78776						
11	1	Führungsbuchse Bushing	PTFE 25% Kohle	08-01-177/23 H162714	08-01-177/23 H162714	08-01-178/23 H207154	08-01-178/23 H207154	08-01-178/23 H207154	08-01-178/23 H207154						
12	1	Führungsbuchse Bushing	KETRON PEEK	08-01-177/23 H162714	08-01-177/23 H162714	3A0 08-01-178/27 H315800	3A0 08-01-178/27 H315800	3A0 08-01-178/27 H315800	3A0 08-01-178/27 H315800						
13	2	Entlüftungstopfen Venting plug	PHT/BLACK				08-60-005/94 H175308								
14	1	O-Ring O-ring	EPDM FDA-konform	58-06-052/64 15,3x2,4 H206007	58-06-078/64 20,2x3 H121794		58-06-078/64 20,2x3 H121794								
15	1	Skt. Schraube Hex. Screw	1.4301	65-01-055/13 4xM6x12 H78750	65-01-081/15 4xM8x16 H78772	65-01-081/15 4xM8x16 H78772	65-01-081/15 4xM8x16 H78772	65-01-130/15 8xM10x16 H78806	65-01-130/15 8xM10x16 H78806						
16	1	Steuerkopf Actuator	1.4301	000 15-32-050/17 H171378	000 15-32-051/17 H171379	000 15-32-051/17 H171379	000 15-32-051/17 H171379	000 15-32-052/17 H171380	000 15-32-052/17 H171380						



Blatt 4 von 7
RN 01.064.10-1

Weitergabe sowie Vervielfältigung dieser Unterlage, Verwertung und Mitteilung ihres Inhalts nicht gestattet, soweit nicht schriftlich zugestanden. Verstoß verpflichtet zum Schadenersatz und kann strafrechtliche Folgen haben (Paragraf 18 UW/G, Paragraf 106 UrhG). Eigentum und alle Rechte, auch für Patenterteilung und Gebrauchsmustererteilung, vorbehalten. SPX FLOW, Germany

pos. item		Menge quantity	Beschreibung description	Material	1-4 Zoll / inch			Date: 25.05.09 02.04.12 25.09.14 10.06.16			Blatt 5 von 7	
					1"	1,5"	2"	2,5"	3"	4"		Trytko
				WS-Nr. ref.-no.	WS-Nr. ref.-no.	WS-Nr. ref.-no.	WS-Nr. ref.-no.	WS-Nr. ref.-no.	WS-Nr. ref.-no.	RN 01.064.10-1		
14	1	Steuerkopf Actuator	Ausf. außen-polierter design outside-polished	1.4301	000 15-32-050/13 H178155	000 15-32-051/13 H177400	000 15-32-052/13 H200827	000 15-32-052/13 H200827	000 15-32-052/13 H200827			
	1	Steuerkopf Actuator	Ausf. außen-3A-Standard design outside -3A-standard	1.4301	3A0 15-32-059/13 H208693	3A0 15-32-060/13 H173538	3A0 15-32-061/13 H173524	3A0 15-32-061/13 H173524	3A0 15-32-061/13 H173524			
15	1	W-Verschr. schwenk. W-Union slewable	G1/8" 1/4"OD	PA-1.4301	08-60-811/93 H312732							
16	1	Entlüftungsstopfen Venting plug	G1/8"	PE-HARD YELLOW	08-60-005/93 H16218							
17	1	O-Ring O-ring	OR 66x2	NBR 70-75 Shore A	58-06-297/83 H173930							
18	1	Zentrierscheibe Centering nut		1.4301	15-28-940/12 H170196							
19	1	Skt. Mutter Hex. Nut	DIN EN ISO 10511 M12-A2	1.4301	65-50-105/15 H112376							
20	1	Schaltnocke Operating cam		1.4523	08-52-290/97 H173086							
21	1	VSM Gehäuse Proximity switch holder housing		Vestamid	15-33-932/93 H173931							
22	4	Skt. Schraube Hex. Screw	DIN EN 24017 M8x16 -A2-70	1.4301	65-01-081/15 H78772							
23	1	Control-Unit Control-Unit	CU41-S-Direkt Connect	PA 6.6 GF 30 schwarz	08-45-100/93 H320460							
24	1	CU4-S-Adapter CU4-S-adapter		PA 6.6 GF 30 schwarz	08-48-600/93 H320474							
25	1	Gehäusedeckel Housing lid	Ausf. 3A- außen matt-gl. design 3A- outside-satin fin.	1.4404	000 39-01-139/47 H107248							
	1	Gehäusedeckel Housing lid	Ausf. außen-3A-Standard design outside -3A-standard	1.4404	3A0 39-01-233/43 H208478							
26		Skt. Schraube Hex. Screw	DIN EN 24017-A2-70	1.4301	65-01-081/15 4xM8x16 H78772							
27	1	O-Ring O-ring		EPDM FDA-konform	58-06-345/64 75.6x5.33 H204241							

Membranventil fan support MSP4, MSEP4, MSTP4 FS-CU und VSM
Diaphragm valve fan support MSP4, MSEP4, MSTP4 FS-CU and PSH

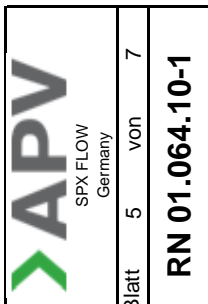

Weitergabe sowie Vervielfältigung dieser Unterlage, Verwertung und Mitteilung ihres Inhalts nicht gestattet, soweit nicht schriftlich zugestanden. Verstoß verpflichtet zum Schadensersatz und kann strafrechtliche Folgen haben (Paragraf 18 UWVG, Paragraf 106 UrhG). Eigentum und alle Rechte, auch für Patenterteilung und Gebrauchsmustererteilung, vorbehalten. SPX FLOW, Germany

Ersatzteilliste: spare parts list

Membranventil fan support MSP4, MSEP4, MSTP4 FS-CU und VSM Diaphragm valve fan support MSP4, MSEP4, MSTP4 FS-CU and PSH 1-4 Zoll / inch

pos. item	Menge quantity	Beschreibung description	Material	1"	1,5"	2"	2,5"	3"	4"
				WS-Nr. ref.-no.	WS-Nr. ref.-no.	WS-Nr. ref.-no.	WS-Nr. ref.-no.	WS-Nr. ref.-no.	WS-Nr. ref.-no.
	1	O-Ring O-ring	FPM FDA-konform				58-06-345/73 75,6x5,33 H320762		
27	1	O-Ring O-ring	HNBR FDA-konform				58-06-345/33 75,6x5,33 H310656		
	1	O-Ring O-ring	VMQ FDA-konform				58-06-345/53 75,6x5,33		
	1	Gehäusedichtung Housing seal	EPDM FDA-konform	58-33-392/93 H77464	58-33-442/93 H77488	58-33-492/93 H77512	58-33-542/93 H77543	58-33-642/93 H77583	58-33-692/93 H77608
28	1	Gehäusedichtung Housing seal	FPM FDA-konform	58-33-392/73 H77463	58-33-442/73 H77487	58-33-492/73 H77511	58-33-542/73 H77542	58-33-642/73 H77582	58-33-692/73 H77607
29	1	Gehäusedichtung Housing seal	HNBR FDA-konform	58-33-392/33 H170018	58-33-442/33 H168714	58-33-492/33 H168759	58-33-542/33 H170075	58-33-642/33 H170074	58-33-692/33 H172125
	4	Skt. Schraube Hex. Screw	1.4301	65-01-079/15 M8x14 H78768				65-01-129/15 M10x14 H78805	
		Dichtungssatz MSP4, MSEP4 Standardausführung / seal kit MSP4, MSEP4 standard design Pos. 2, 5, 10, 12, 17, 19 nur im kompletten Dichtungssatz erhältlich / Item 2, 5, 10, 12, 17, 19 available es complete seal kits only							
		Dichtungssatz Seal kit	PTFE	58-36-810/03 H328461	58-36-811/03 H328462	58-36-812/03 H328463	58-36-813/03 H328464	58-36-814/03 H328465	58-36-815/03 H328466
		Dichtungssatz MSEP4 Ausführung -3A / seal kit MSEP4 design -3A Pos. 2, 5, 10, 12, 17, 19, 27 nur im kompletten Dichtungssatz erhältlich / Item 2, 5, 10, 12, 17, 19, 27 available es complete seal kits only							
		Dichtungssatz Seal kit	PTFE / FPM	3A0 58-36-810/00	3A0 58-36-811/00	3A0 58-36-812/00	3A0 58-36-817/00	3A0 58-36-818/00	3A0 58-36-819/00
		Dichtungssatz Seal kit	PTFE / EPDM	3A0 58-36-810/01	3A0 58-36-811/01	3A0 58-36-812/01	3A0 58-36-817/01	3A0 58-36-818/01	3A0 58-36-819/01
		Dichtungssatz Seal kit	PTFE / VMQ	3A0 58-36-810/02	3A0 58-36-811/02	3A0 58-36-812/02	3A0 58-36-817/02	3A0 58-36-818/02	3A0 58-36-819/02
		Dichtungssatz Seal kit	PTFE / HNBR	3A0 58-36-810/06	3A0 58-36-811/06	3A0 58-36-812/06	3A0 58-36-817/06	3A0 58-36-818/06	3A0 58-36-819/06

Datum: 25.05.09 02.04.12 25.09.14 10.06.16
Name: Trytko Trytko Trytko
Geprüft: Schulz Schulz Schulz

Datum: Name: Geprüft: Blatt 6 von 7
RN 01.064.10-1



Weitergabe sowie Vervielfältigung dieser Unterlage, Verwertung und Mitteilung ihres Inhalts nicht gestattet, soweit nicht schriftlich zugestanden. Verstoß verpflichtet zum Schadensersatz und kann strafrechtliche Folgen haben (Paragraph 18 UWG, Paragraph 106 UrhG). Eigentum und alle Rechte, auch für Patenterteilung und Gebrauchsmustereintragung, vorbehalten. SPX FLOW, Germany

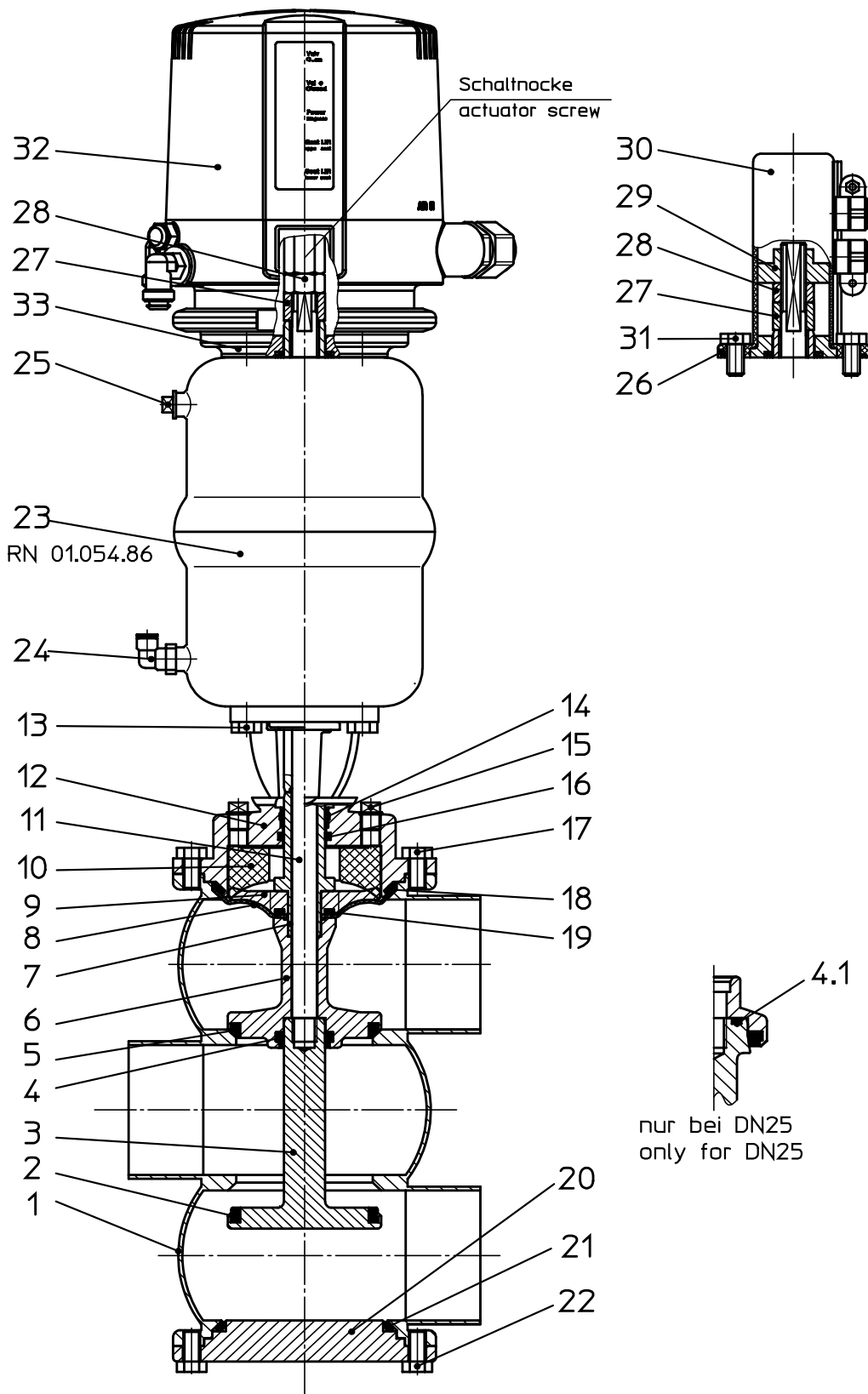

Pos. 24 und 25 nur bei Steuerkopf 3A-Ausführung
item. 24 and 25 only for actuator 3A-design



Datum:	02.07.09	26.03.12	05.03.13	18.09.14	10.06.16					
Name:	Trytko	Trytko	Trytko	Trytko	Trytko					
Geprüft:	Schulz	Schulz	Schulz	Schulz						

Ersatzteilliste: spare parts list

Membranventil fan support MSES4 FS-CU und VSM
Diaphragm valve fan support MSES4 FS-CU and PSH
DN 25-100



SPX FLOW
Germany

Blatt 1 von 6

RN 01.064.12

Weitergabe sowie Vervielfältigung dieser Unterlage, Verwertung und Mitteilung ihres Inhalts nicht gestattet, soweit nicht schriftlich zugestanden. Verstoß verpflichtend zum Schadensersatz und kann strafrechtliche Folgen haben (Paragraf 18 UWVG, Paragraf 106 UrhG). Eigentum und alle Rechte, auch für Patenterteilung und Gebrauchsmustereintragung, vorbehalten. SPX FLOW, Germany

Ersatzteilliste: spare parts list

Membranventil fan support MSES4 FS-CU und VSM Diaphragm valve fan support MSES4 FS-CU and PSH DN25-100

pos. item	Menge quantity	Beschreibung description	Material	DN25	DN40	DN50	DN65			DN80			DN100
							WS-Nr. ref.-no.	WS-Nr. ref.-no.	WS-Nr. ref.-no.	WS-Nr. ref.-no.	WS-Nr. ref.-no.	WS-Nr. ref.-no.	
1	1	Gehäuse MESH45 Housing MESH45	1.4404	000 39-49-295/47 H176955	000 39-49-395/47 H176962	000 39-49-445/47 H176963	000 39-49-495/47 H176964	000 39-49-545/47 H176966	000 39-49-645/47 H176967				
	1	Gehäuse MESH46 Housing MESH46	1.4404	000 39-50-295/47 H331220	000 39-50-395/47 H324280	000 39-50-445/47 H206405	000 39-50-495/47 H200921	000 39-50-545/47 H201915					
	1	Gehäuse MESH47 Housing MESH47	1.4404										
	1	Gehäuse MESH48 Housing MESH48	1.4404				000 39-51-485/47 H201525						
	1	Gehäuse MESH45 Housing MESH45	1.4404										
	1	Gehäuse MESH46 Housing MESH46	1.4404										
	1	Gehäuse MESH47 Housing MESH47	1.4404										
	1	Gehäuse MESH48 Housing MESH48	1.4404										
	1	Gehäuse MESH45 Housing MESH45	1.4404	000 39-49-295/43	000 39-49-395/43	000 39-49-445/43	000 39-49-495/43	000 39-49-545/43	000 39-49-645/43				
	1	Gehäuse MESH46 Housing MESH46	1.4404										
	1	Gehäuse MESH47 Housing MESH47	1.4404										
	1	Gehäuse MESH48 Housing MESH48	1.4404										
	1	Gehäuse MESH45 Housing MESH45	1.4404										
	1	Gehäuse MESH46 Housing MESH46	1.4404										
	1	Gehäuse MESH47 Housing MESH47	1.4404										
	1	Gehäuse MESH48 Housing MESH48	1.4404										

Datum:	02.07.09	26.03.12	05.03.13	18.09.14
Name:	Trytko	Trytko	Trytko	Trytko
Geprüft:	Schulz	Schulz	Schulz	Schulz

Datum:	10.06.16
Name:	Trytko
Geprüft:	

Blatt 2 von 6
RN 01.064.12



Weitergabe sowie Vervielfältigung dieser Unterlage, Verwertung und Mitteilung ihres Inhalts nicht gestattet, soweit nicht schriftlich zugestanden. Verstoß verpflichtet zum Schadensersatz und kann strafrechtliche Folgen haben (Paragraf 18 UW.G, Paragraf 106 UrtG). Eigentum und alle Rechte, auch für Patenterteilung und Gebrauchsmustererteilung, vorbehalten. SPX FLOW, Germany

Ersatzteilliste: spare parts list

Membranventil fan support MSES4 FS-CU und VSM Diaphragm valve fan support MSES4 FS-CU and PSH DN25-100

pos. item	Menge quantity	Beschreibung description	Material	DN25	DN40	DN50	DN65	DN80	DN100
				WS-Nr. ref.-no.	WS-Nr. ref.-no.	WS-Nr. ref.-no.	WS-Nr. ref.-no.	WS-Nr. ref.-no.	WS-Nr. ref.-no.
2	1	Tellerdichtung Seat seal	EPDM FDA-konform	58-33-293/93 H77442	58-33-393/93 H77467	58-33-443/93 H77491	58-33-493/93 H77515	58-33-543/93 H77546	58-33-643/93 H77586
	1	Tellerdichtung Seat seal	FPM FDA-konform	58-33-293/73 H77441	58-33-393/73 H77466	58-33-443/73 H77490	58-33-493/73 H77514	58-33-543/73 H77545	58-33-643/73 H77585
	1	Tellerdichtung Seat seal	HNBR FDA-konform	58-33-293/33 H170176	58-33-393/33 H166676	58-33-443/33 H166085	58-33-493/33 H166678	58-33-543/33 H166681	58-33-643/33 H166682
	1	Tellerdichtung Seat seal	VMQ FDA-konform	58-33-293/13 H77440	58-33-393/13 H77465	58-33-443/13 H77489	58-33-493/13 H77513	58-33-543/13 H77544	58-33-643/13 H77584
3	1	Schaft unten Lower valve shaft	1.4404	39-22-800/42 H176983	39-22-801/42 H176995	39-22-802/42 H176996	39-22-803/42 H176997	39-22-804/42 H176998	39-22-805/42 H176999
	1	Schaftdichtung Shaft seal	EPDM FDA-konform				58-33-019/94 H331328		
4	1	Schaftdichtung Shaft seal	FPM FDA-konform				58-33-019/74 H331338		
	1	Schaftdichtung Shaft seal	HNBR FDA-konform				58-33-019/33 H331339		
4.1	1	O-Ring O-ring	VMQ	58-06-050/53 11,3x2,4 H206351					
	1	Tellerdichtung Seat seal	EPDM FDA-konform	58-33-293/93 H77442	58-33-393/93 H77467	58-33-443/93 H77491	58-33-493/93 H77515	58-33-543/93 H77546	58-33-643/93 H77586
5	1	Tellerdichtung Seat seal	FPM FDA-konform	58-33-293/73 H77441	58-33-393/73 H77466	58-33-443/73 H77490	58-33-493/73 H77514	58-33-543/73 H77545	58-33-643/73 H77585
	1	Tellerdichtung Seat seal	HNBR FDA-konform	58-33-293/33 H170176	58-33-393/33 H166676	58-33-443/33 H166085	58-33-493/33 H166678	58-33-543/33 H166681	58-33-643/33 H166682
6	1	Tellerdichtung Seat seal	VMQ FDA-konform	58-33-293/13 H77440	58-33-393/13 H77465	58-33-443/13 H77489	58-33-493/13 H77513	58-33-543/13 H77544	58-33-643/13 H77584
	1	Schaft mitte Middle valve shaft	1.4404	000 39-22-806/42 H176981	000 39-22-809/42 H177000	000 39-22-810/42 H177001	000 39-22-811/42 H177002	000 39-22-812/42 H177003	000 39-22-813/42 H177004
7	1	Schaft mitte Middle valve shaft	1.4404	3A0 39-22-808/43 H320985	3A0 39-22-809/43 H320986	3A0 39-22-810/43 H320987	3A0 39-22-811/43 H320988	3A0 39-22-812/43 H320989	3A0 39-22-813/43 H320990
	1	Schaft oben Upper valve shaft	1.4301	39-22-070/12 H318486	39-22-071/12 H318487		39-22-072/12 H318488	39-22-073/12 H318489	39-22-074/12 H318490



Blatt 3 von 6
RN 01.064.12

Ersatzteilliste: spare parts list

Membranventil fan support MSES4 FS-CU und VSM Diaphragm valve fan support MSES4 FS-CU and PSH DN25-100

pos. item	Menge quantity	Beschreibung description	Material	DN25	DN40	DN50	DN65	DN80	Date:		Blatt	
				WS-Nr. ref.-no.	WS-Nr. ref.-no.	WS-Nr. ref.-no.	WS-Nr. ref.-no.	WS-Nr. ref.-no.	Trytko	Trytko	von	6
8	1	Membrane Diaphragm	TFM FDA-konform	58-23-050/23 H318545	58-23-051/23 H318544	58-23-052/23 H318543	58-23-053/23 H318542	58-23-054/23 H318541	18.09.14	Trytko	Trytko	RN 01.064.12
9	1	Stern Star	1.4301	08-48-520/12 H320414	08-48-521/12 H320249	08-48-522/12 H319397	08-48-523/12 H320316	08-48-524/12 H320332	10.06.16	Schulz	Schulz	
10	1	Membranunterstützung Fan support	Ryton R4-XT	08-48-510/93 H318532	08-48-511/93 H318533	08-48-512/93 H318534	08-48-513/93 H318535	08-48-514/93 H318536		Trytko		
11	1	Zugstange Guide rod	1.4305	39-23-080/12 H202599	39-23-129/12 H320621	39-23-083/12 H330128		39-23-130/12 H320577				
12	1	Laterne Ausführung matt-gl. design satin fin.	1.4404	000 39-40-040/47 H318491	000 39-40-041/47 H318492	000 39-40-042/47 H318493	000 39-40-043/47 H318494	000 39-40-044/47 H320578				
13	4	Laterne Ausführung poliert design polished	1.4404	000 39-40-040/43	000 39-40-041/43	000 39-40-042/43	000 39-40-043/43	000 39-40-044/43				
14	1	Laterne Ausführung 3A-blank design 3A-bright fin.	1.4404	3A0 39-40-040/43 H320458	3A0 39-40-041/43 H320355	3A0 39-40-042/43 H319373	3A0 39-40-043/43 H320320	3A0 39-40-044/43 H318495				
15	2	Skt. Schraube Hex. Screw	1.4301	DIN EN 24017-A2-70	65-01-081/15 M8x16 H78772	65-01-083/15 M8x20 H78776						
16	1	Führungsbuchse Standardausführung standard design	PTFE 25% Kohle	08-01-177/23 H162714	08-01-178/23 H207154	08-01-178/23 H207154						
17	1	Führungsbuchse Ausführung -3A design -3A	KETRON PEEK	08-01-177/23 H162714	3A0 08-01-178/27 H315800							
18	1	Entlüftungstopfen Venting plug	PHT/BLACK		08-60-005/94 H175308							
19	1	O-Ring	EPDM	58-06-052/64 15,3x2,4 H206007	58-06-078/64 20,2x3 H121794							
20	1	O-Ring	FDA-konform	65-01-055/13 4xM6x12 H78750	65-01-081/15 4xM8x16 H78772	65-01-130/15 8xM10x16 H78806						
21	1	O-Ring	EPDM	58-06-144/64 35x3,5 H324909	58-06-269/64 60x4 H324910	58-06-340/64 75x4,5 H324911	58-06-488/64 95x4,5 H324912	58-06-581/64 120x4,5 H324913				
22	1	O-Ring	EPDM	58-06-038/64 11x2,5 H320269	58-06-067/64 18x3 H320261	58-06-083/64 22x3,5 H319390	58-06-098/64 24x3,5 H320270	58-06-140/64 31,1x3,5 H320271				
23	1	Gehäusedeckel Housing lid	1.4404	39-01-230/47 H176062	39-01-138/47 H68670	39-01-139/47 H107248	39-01-140/47 H68671	39-01-143/47 H107251				

Weitergabe sowie Vervielfältigung dieser Unterlage, Verwertung und Mitteilung ihres Inhalts nicht gestattet, soweit nicht schriftlich zugestanden. Verstößt verpflichtet zum Schadensersatz und kann strafrechtliche Folgen haben (Paragraf 18 UWG, Paragraf 106 UrhG). Eigentum und alle Rechte, auch für Patenterteilung und Gebrauchsmusterteilung, vorbehalten. SPX FLOW, Germany

Ersatzteilliste: spare parts list

Membranventil fan support MSES4 FS-CU und VSM Diaphragm valve fan support MSES4 FS-CU and PSH DN25-100

pos. item	Menge quantity	Beschreibung description	Material	DN25	DN40	DN50	Datum:			Blatt			
							WS-Nr. ref.-no.	WS-Nr. ref.-no.	WS-Nr. ref.-no.	Trytko	Trytko	Trytko	Schulz
20	1	Gehäusedeckel Housing lid	1.4404	39-01-230/43	39-01-138/43 H201051	39-01-139/43	02.07.09	10.06.16	05.03.13	18.09.14	RN 01.064.12		
	1	Gehäusedeckel Housing lid	1.4404	3A0 39-01-230/43 H206991	3A0 39-01-235/43 H313965	3A0 39-01-233/43 H208478	Trytko	Trytko	Trytko	Trytko	Schulz	Schulz	Schulz
21	1	O-Ring	EPDM	58-06-157/64	58-06-300/64	58-06-300/64	58-06-495/64	58-06-495/64	58-06-495/64	58-06-520/64			
	1	O-Ring	FDA-konform	36,5X3,2 H174257	62,9x5,33 H204240	75,6x5,33 H204241	75,6x5,33 H204242	101x5,33 H204242	101x5,33 H204242	119,2x5,7 H204243			
	1	O-Ring	FPM	58-06-157/73	58-06-300/73	58-06-345/73	58-06-345/73	58-06-495/73	58-06-495/73	58-06-520/73			
	1	O-Ring	FDA-konform	36,5X3,2 H207142	62,9x5,33 H312008	75,6x5,33 H320762	75,6x5,33 H320762	101x5,33	101x5,33	119,2x5,7			
	1	O-Ring	HNBR	58-06-157/33	58-06-300/33	58-06-345/33	58-06-495/33	58-06-495/33	58-06-520/33	58-06-520/33			
	1	O-Ring	FDA-konform	36,5X3,2 H310653	62,9x5,33 H310654	75,6x5,33 H310656	75,6x5,33 H310657	101x5,33 H310657	101x5,33 H310657	119,2x5,7 H310658			
22	1	O-Ring	VMQ	58-06-157/53	58-06-300/53	58-06-345/53	58-06-495/53	58-06-495/53	58-06-520/53				
	1	O-Ring	FDA-konform	36,5X3,2 H122830	62,9x5,33 H206352	75,6x5,33	75,6x5,33	101x5,33	101x5,33	119,2x5,7			
23	1	Skt. Schraube Hex. Screw	1.4301	65-01-055/13 4xM6x12 H78750	65-01-081/15 4xM8x16 H78772	65-01-130/15 8xM10x16 H78806	000 15-32-051/17 H171379	000 15-32-052/17 H171380	000 15-32-052/17 H171380				
	1	Steuerkopf Actuator	1.4301	000 15-32-050/17 H171378	000 15-32-051/13 H177400	000 15-32-052/13 H200827	000 15-32-051/13 H177400	000 15-32-052/13 H200827	000 15-32-052/13 H200827				
	1	Steuerkopf Actuator	1.4301	000 15-32-050/13 H178155	3A0 15-32-060/13 H173538	3A0 15-32-061/13 H173524	3A0 15-32-059/13 H208693	3A0 15-32-060/13 H173538	3A0 15-32-061/13 H173524				
	1	Steuerkopf Actuator	1.4301	3A0 15-32-059/13 H208693	3A0 15-32-060/13 H173538	3A0 15-32-061/13 H173524	3A0 15-32-059/13 H208693	3A0 15-32-060/13 H173538	3A0 15-32-061/13 H173524				
24	1	W-Versch. schwenk. W-Union slewable	PA-1.4301	08-60-811/93 H312732	08-60-811/93 H312732	08-60-811/93 H312732	08-60-811/93 H312732	08-60-811/93 H312732	08-60-811/93 H312732				
	1	Entlüftungsstopfen Venting plug	PE-HARD YELLOW	08-60-005/93 H16218	08-60-005/93 H16218	08-60-005/93 H16218	08-60-005/93 H16218	08-60-005/93 H16218	08-60-005/93 H16218				
25	1	O-Ring	NBR	58-06-297/83 H173930	58-06-297/83 H173930	58-06-297/83 H173930	58-06-297/83 H173930	58-06-297/83 H173930	58-06-297/83 H173930				
	1	O-ring	70-75 Shore A	15-28-940/12 H170196	15-28-940/12 H170196	15-28-940/12 H170196	15-28-940/12 H170196	15-28-940/12 H170196	15-28-940/12 H170196				
26	1	Zentrierscheibe Centering nut	1.4301	65-50-105/15 H112376	65-50-105/15 H112376	65-50-105/15 H112376	65-50-105/15 H112376	65-50-105/15 H112376	65-50-105/15 H112376				
	1	Skt. Mutter Hex. Nut	1.4301	08-52-290/97 H173086	08-52-290/97 H173086	08-52-290/97 H173086	08-52-290/97 H173086	08-52-290/97 H173086	08-52-290/97 H173086				
27	1	Schaltlocke Operating cam	1.4523	08-52-290/97 H173086	08-52-290/97 H173086	08-52-290/97 H173086	08-52-290/97 H173086	08-52-290/97 H173086	08-52-290/97 H173086				
	1	Operating cam	1.4523	08-52-290/97 H173086	08-52-290/97 H173086	08-52-290/97 H173086	08-52-290/97 H173086	08-52-290/97 H173086	08-52-290/97 H173086				



Weitergabe sowie Vervielfältigung dieser Unterlage, Verwertung und Mitteilung ihres Inhalts nicht gestattet, soweit nicht schriftlich zugestanden. Verstößt verpflichtet zum Schadensersatz und kann strafrechtliche Folgen haben. (Paragraf 18 UJWG, Paragraph 106 UrtG), Eigentum und alle Rechte, auch für Patenterteilung und Gebrauchsmustererteilung, vorbehalten. SPX FLOW, Germany

Ersatzteilliste: spare parts list		Datum: 02.07.09		26.03.12		05.03.13		18.09.14	
		Name: Trytko	Trytko	Trytko	Trytko	Trytko	Trytko	Trytko	Trytko
		Geprüft: Schulz		Schulz		Schulz		Schulz	
		Datum: 10.06.16							
		Name: Trytko							
		Geprüft:							
		Blatt 6		von		6			
		RN 01.064.12							



Membranventil fan support MSES4 FS-CU und VSM Diaphragm valve fan support MSES4 FS-CU and PSH DN25-100

pos. item	Menge quantity	Beschreibung description	Material	DN25	DN40	DN50	DN65	DN80	DN100
				WS-Nr. ref.-no.	WS-Nr. ref.-no.	WS-Nr. ref.-no.	WS-Nr. ref.-no.	WS-Nr. ref.-no.	WS-Nr. ref.-no.
30	1	VSM Gehäuse Proximity switch holder housing	Vestamid						
31	4	Skt. Schraube Hex. Screw DIN EN 24017 M8x16 -A2-70	1.4301						
32	1	Control-Unit Control-Unit CU41-S-Direckt Connect	PA 6.6 GF 30 schwarz						
33	1	CU4-S-Adapter CU4-S-adapter	PA 6.6 GF 30 schwarz						
Dichtungssatz Standardausführung / seal kit standard design Pos. 2, 4, 4.1, 5, 8, 14, 16, 18, 19, 21, 28 nur im kompletten Dichtungssatz erhältlich / Item 2, 4, 4.1, 5, 8, 14, 16, 18, 19, 21, 28 available es complete seal kits only									
1	1	Dichtungssatz Seal kit	TFM / FPM	58-36-933/00	58-36-934/00	58-36-935/00	58-36-936/00	58-36-937/00	58-32-938/00
1	1	Dichtungssatz Seal kit	TFM / EPDM	58-36-933/01 H329275	58-36-934/01 H329276	58-36-935/01 H327556	58-36-936/01 H332837	58-36-937/01	58-36-938/01
1	1	Dichtungssatz Seal kit	TFM / VMQ	58-36-933/02	58-36-934/02	58-36-935/02	58-36-936/02	58-36-937/02	58-36-938/02
1	1	Dichtungssatz Seal kit	TFM / HNBR	58-36-933/06	58-36-934/06 H328836	58-36-935/06 H331999	58-36-936/06	58-36-937/06	58-36-938/06
Dichtungssatz Ausführung -3A / seal kit design -3A Pos. 2, 4, 4.1, 5, 8, 14, 16, 18, 19, 21, 28 nur im kompletten Dichtungssatz erhältlich / Item 2, 4, 4.1, 5, 8, 14, 16, 18, 19, 21, 28 available es complete seal kits only									
1	1	Dichtungssatz Seal kit	TFM / FPM	3A0 58-36-933/00	3A0 58-36-934/00	3A0 58-36-935/00	3A0 58-36-936/00	3A0 58-36-937/00	3A0 58-32-938/00
1	1	Dichtungssatz Seal kit	TFM / EPDM	3A0 58-36-933/01	3A0 58-36-934/01	3A0 58-36-935/01	3A0 58-36-936/01	3A0 58-36-937/01	3A0 58-36-938/01
1	1	Dichtungssatz Seal kit	TFM / VMQ	3A0 58-36-933/02	3A0 58-36-934/02	3A0 58-36-935/02	3A0 58-36-936/02	3A0 58-36-937/02	3A0 58-36-938/02
1	1	Dichtungssatz Seal kit	TFM / HNBR	3A0 58-36-933/06	3A0 58-36-934/06	3A0 58-36-935/06	3A0 58-36-936/06	3A0 58-36-937/06	3A0 58-36-938/06

Weitergabe sowie Vervielfältigung dieser Unterlage, Verwertung und Mitteilung ihres Inhalts nicht gestattet, soweit nicht schriftlich zugestanden. Verstößt verpflichtet zum Schadensersatz und kann strafrechtliche Folgen haben (Paragraf 18 UWG, Paragraf 106 UrhG). Eigentum und alle Rechte, auch für Patenterteilung und Gebrauchsmustereintragung, vorbehalten. SPX FLOW, Germany

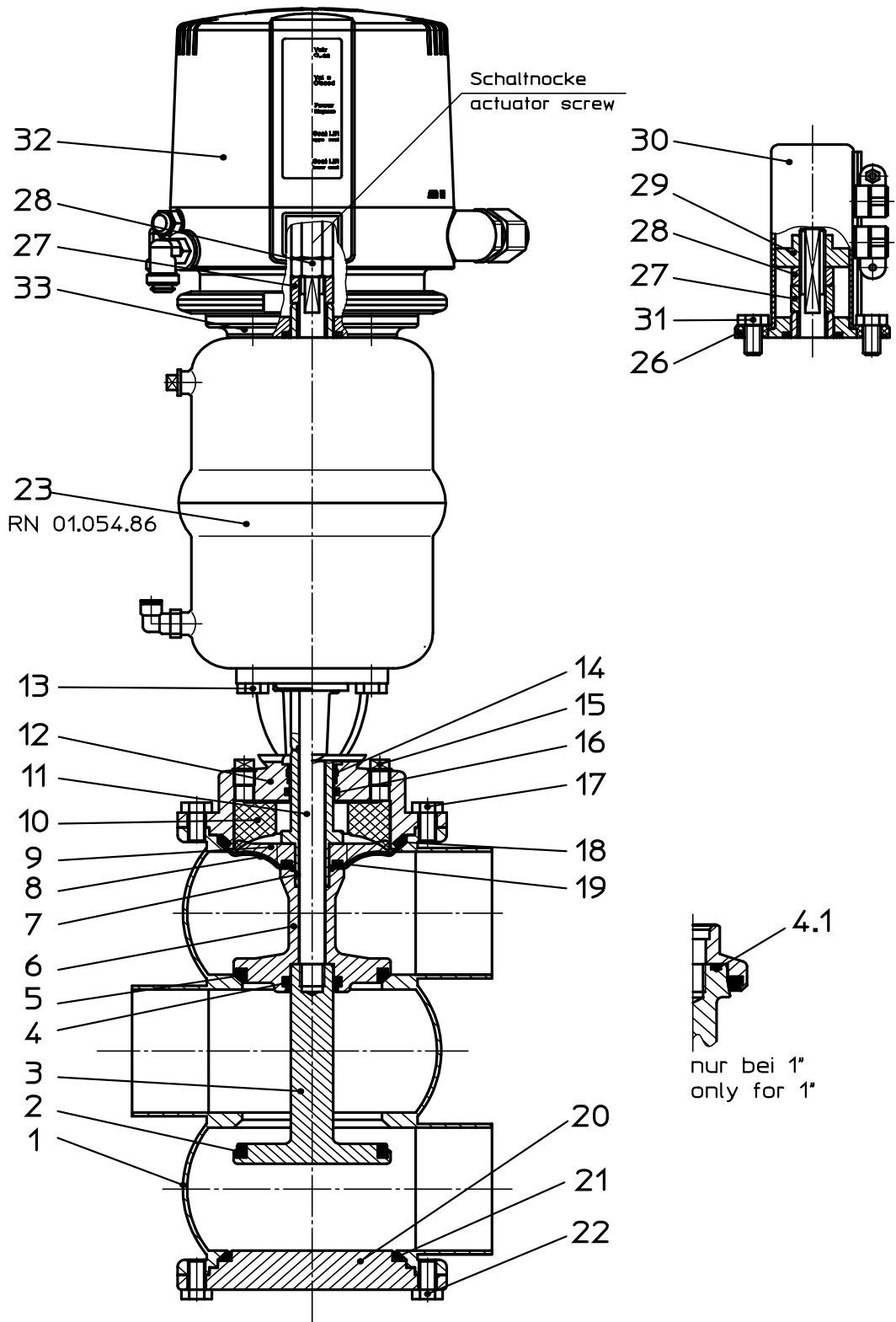

Datum:	07.07.09	07.05.12	05.03.13	18.09.14	23.10.14	26.11.15	10.06.16	11.10.16		
Name:	Trytko	Trytko	Trytko	Trytko	Trytko	Trytko	Trytko	C.Keil		
Geprüft:	Schulz	Schulz	Schulz	Schulz						

Ersatzteilliste: spare parts list

Membranventil fan support MSES4 FS-CU und VSM
Diaphragm valve fan support MSES4 FS-CU and PSH
1-4 Zoll / inch



SPX FLOW
Germany

Blatt 1 von 6

RN 01.064.12-1

Ersatzteilliste: spare parts list

Membranventil fan support MSES4 FS-CU und VSM Diaphragm valve fan support MSES4 FS-CU and PSH 1-4 Zoll / inch

		Blatt 2 von 6	
Datum: 07.07.09		18.09.14	
Name: Trytko	Trytko	Trytko	Trytko
Geprüft: Schulz	Schulz	Schulz	Schulz
Datum: 23.10.14		11.10.16	
Name: Trytko	Trytko	Trytko	C.Keil
Geprüft:			
RN 01.064.12-1			

pos. item	Menge quantity	Beschreibung description	Material	1,5" 2" 2,5" 3" 4"				
				1"	2"	2,5"	3"	4"
			WS-Nr. ref.-no.	WS-Nr. ref.-no.	WS-Nr. ref.-no.	WS-Nr. ref.-no.	WS-Nr. ref.-no.	
1	1	Gehäuse MESH45 Housing MESH45 Standardausf. matt-gl. standard design satin fin.	1.4404	000 39-49-320/47 H176956	000 39-49-470/47 H176969	000 39-49-520/47 H176970	000 39-49-570/47 H176971	000 39-49-670/47 H176972
1	1	Gehäuse MESH46 Housing MESH46 Standardausf. matt-gl. standard design satin fin.	1.4404	000 39-50-320/47 H331850	000 39-50-470/47 H178501	000 39-50-520/47 H206292	000 39-50-570/47 H312048	000 39-50-670/47
1	1	Gehäuse MESH47 Housing MESH47 Standardausf. matt-gl. standard design satin fin.	1.4404					
1	1	Gehäuse MESH48 Housing MESH48 Standardausf. matt-gl. standard design satin fin.	1.4404	000 39-51-310/47 H203476	000 39-51-460/47			
1	1	Gehäuse MESH45 Housing MESH45 Ausf. 3A-außen matt-gl. design 3A-outside-satin fin.	1.4404	3A0 39-49-320/47 H329270	3A0 39-49-052/47 H329246	3A0 39-49-054/47 H325446	3A0 39-49-055/47	
1	1	Gehäuse MESH46 Housing MESH46 Ausf. 3A-außen matt-gl. design 3A-outside-satin fin.	1.4404		3A0 39-50-457/47 H321111	3A0 39-50-020/47 H328447		
1	1	Gehäuse MESH47 Housing MESH47 Ausf. 3A-außen matt-gl. design 3A-outside-satin fin.	1.4404					
1	1	Gehäuse MESH48 Housing MESH48 Ausf. 3A-außen matt-gl. design 3A-outside-satin fin.	1.4404		3A0 39-50-457/47 H321111	3A0 39-51-510/47 H326093		
1	1	Gehäuse MESH45 Housing MESH45 Ausf. außen-poliert design outside-polished	1.4404	000 39-49-320/43	000 39-49-420/43	000 39-49-520/43	000 39-49-570/43	000 39-49-670/43
1	1	Gehäuse MESH46 Housing MESH46 Ausf. außen-poliert design outside-polished	1.4404		000 39-50-420/43 H201997		000 39-50-570/43 H201041	
1	1	Gehäuse MESH47 Housing MESH47 Ausf. außen-poliert design outside-polished	1.4404					
1	1	Gehäuse MESH48 Housing MESH48 Ausf. außen-poliert design outside-polished	1.4404		000 39-51-460/43 H201229			
1	1	Gehäuse MESH45 Housing MESH45 Ausf. außen -3A-Standard design outside -3A-standard	1.4404	3A0 39-49-320/43 H206995	3A0 39-49-052/43 H323546	3A0 39-49-054/43 H327070	3A0 39-49-055/43 H206724	
1	1	Gehäuse MESH46 Housing MESH46 Ausf. außen -3A-Standard design outside -3A-standard	1.4404		3A0 39-50-003/43 H313961	3A0 39-50-020/43 H208480		
1	1	Gehäuse MESH47 Housing MESH47 Ausf. außen -3A-Standard design outside -3A-standard	1.4404					
1	1	Gehäuse MESH48 Housing MESH48 Ausf. außen -3A-Standard design outside -3A-standard	1.4404		3A0 39-50-003/43 H313961	3A0 39-51-510/43 H316544		

Ersatzteilliste: spare parts list

Membranventil fan support MSES4 FS-CU und VSM Diaphragm valve fan support MSES4 FS-CU and PSH 1-4 Zoll / inch

Datum:	07.07.09	07.05.12	05.03.13	18.09.14
Name:	Trytko	Trytko	Trytko	Trytko
Geprüft:	Schulz	Schulz	Schulz	Schulz

Datum:	23.10.14	26.11.15	10.06.16	11.10.16
Name:	Trytko	Trytko	Trytko	C.Keil
Geprüft:				



Blatt 3 von 6
RN 01.064.12-1

pos. item	Menge quantity	Beschreibung description	Material	1"	1,5"	2"	2,5"	3"	4"
				WS-Nr. ref.-no.	WS-Nr. ref.-no.	WS-Nr. ref.-no.	WS-Nr. ref.-no.	WS-Nr. ref.-no.	
2	1	Tellerdichtung Seat seal	EPDM FDA-konform	58-33-293/93 H77442	58-33-393/93 H77467	58-33-443/93 H77491	58-33-493/93 H77515	58-33-568/93 H77561	58-33-643/93 H77586
	1	Tellerdichtung Seat seal	FPM FDA-konform	58-33-293/73 H77441	58-33-393/73 H77466	58-33-443/73 H77490	58-33-493/73 H77514	58-33-568/73 H77560	58-33-643/73 H77585
	1	Tellerdichtung Seat seal	HNBR FDA-konform	58-33-293/33 H170176	58-33-393/33 H166676	58-33-443/33 H166085	58-33-493/33 H166678	58-33-568/33 H166679	58-33-643/33 H166682
	1	Tellerdichtung Seat seal	VMQ FDA-konform	58-33-293/13 H77440	58-33-393/13 H77465	58-33-443/13 H77489	58-33-493/13 H77513	58-33-568/13 H77559	58-33-643/13 H77584
3	1	Schaft unten Lower valve shaft	1.4404	39-22-816/42 H176984	39-22-817/42 H177022	39-22-818/42 H177023	39-22-819/42 H177024	39-22-820/42 H177025	39-22-812/42 H177027
4	1	Schaftdichtung Shaft seal	EPDM FDA-konform				58-33-019/94 H331328		
	1	Schaftdichtung Shaft seal	FPM FDA-konform				58-33-019/74 H331338		
	1	Schaftdichtung Shaft seal	HNBR FDA-konform				58-33-019/33 H331339		
	1	O-Ring O-ring	VMQ	58-06-050/53 11,3x2,4 H206351					
5	1	Tellerdichtung Seat seal	EPDM FDA-konform	58-33-293/93 H77442	58-33-393/93 H77467	58-33-443/93 H77491	58-33-493/93 H77515	58-33-568/93 H77561	58-33-643/93 H77586
	1	Tellerdichtung Seat seal	FPM FDA-konform	58-33-293/73 H77441	58-33-393/73 H77466	58-33-443/73 H77490	58-33-493/73 H77514	58-33-568/73 H77560	58-33-643/73 H77585
	1	Tellerdichtung Seat seal	HNBR FDA-konform	58-33-293/33 H170176	58-33-393/33 H166676	58-33-443/33 H166085	58-33-493/33 H166678	58-33-568/33 H166679	58-33-643/33 H166682
	1	Tellerdichtung Seat seal	VMQ FDA-konform	58-33-293/13 H77440	58-33-393/13 H77465	58-33-443/13 H77489	58-33-493/13 H77513	58-33-568/13 H77559	58-33-643/13 H77584
6	1	Schaft mitte Middle valve shaft	1.4404	000 39-22-824/42 H176982	000 39-22-825/42 H177028	000 39-22-826/42 H177029	000 39-22-827/42 H177030	000 39-22-828/42 H177031	000 39-22-829/42 H177032
	1	Schaft mitte Middle valve shaft	1.4404	3A0 39-22-824/43 H320991	3A0 39-22-825/43 H320992	3A0 39-22-826/43 H320993	3A0 39-22-827/43 H319372	3A0 39-22-828/43 H320994	3A0 39-22-829/43 H320995
7	1	Schaft oben Upper valve shaft	1.4301	39-22-070/12 H318486	39-22-071/12 H318487		39-22-072/12 H318488		39-22-074/12 H318490

Weitergabe sowie Vervielfältigung dieser Unterlage, Verwertung und Mitteilung ihres Inhalts nicht gestattet, soweit nicht schriftlich zugestanden. Verstößt verpflichtet zum Schadensersatz und kann strafrechtliche Folgen haben (Paragraf 18 UWG, Paragraf 106 UrnG). Eigentum und alle Rechte, auch für Patentierung und Gebrauchsmustereintragung, vorbehalten. SPX FLOW, Germany

Ersatzteilliste: spare parts list

Membranventil fan support MSES4 FS-CU und VSM Diaphragm valve fan support MSES4 FS-CU and PSH 1-4 Zoll / inch

Datum:	07.07.09	Trytko	Trytko	05.03.13	18.09.14
Name:	Trytko	Trytko	Trytko	Trytko	Trytko
Geprüft:	Schulz	Schulz	Schulz	Schulz	Schulz

Datum:	23.10.14	Trytko	Trytko	10.06.16	11.10.16
Name:	Trytko	Trytko	Trytko	Trytko	C.Keil
Geprüft:					



				Blatt	4 von	6
RN 01.064.12-1						

pos. item	Menge quantity	Beschreibung description	Material	1"		1,5"		2"		2,5"		3"		4"	
				WS-Nr. ref.-no.	WS-Nr. ref.-no.	WS-Nr. ref.-no.	WS-Nr. ref.-no.	WS-Nr. ref.-no.	WS-Nr. ref.-no.	WS-Nr. ref.-no.	WS-Nr. ref.-no.	WS-Nr. ref.-no.	WS-Nr. ref.-no.	WS-Nr. ref.-no.	
8	1	Membrane Diaphragm	TFM FDA-konform	58-23-050/23 H318545	58-23-051/23 H318544	58-23-052/23 H318543	58-23-053/23 H318542	58-23-054/23 H318541							
9	1	Stern Star	1.4301	08-48-520/12 H320414	08-48-521/12 H320249	08-48-522/12 H319397	08-48-523/12 H320316	08-48-524/12 H320332							
10	1	Membranunterstützung Fan support	Ryton R4-XT	08-48-510/93 H318532	08-48-511/93 H318533	08-48-512/93 H318534	08-48-513/93 H318535	08-48-514/93 H318536							
11	1	Zugstange Guide rod	1.4305	39-23-080/12 H202599	39-23-129/12 H320621	39-23-083/12 H330128		39-23-130/12 H320577							
12	1	Laterne Ausführung matt-gl. design satin fin.	1.4404	000 39-40-040/47 H318491	000 39-40-041/47 H318492	000 39-40-042/47 H318493	000 39-40-043/47 H318494	000 39-40-044/47 H320578							
13	4	Laterne Ausführung poliert design polished	1.4404	000 39-40-040/43	000 39-40-041/43	000 39-40-042/43	000 39-40-043/43	000 39-40-044/43							
14	1	Laterne Ausführung -3A blank design outside -3A bright fin.	1.4404	3A0 39-40-040/43 H320458	3A0 39-40-041/43 H320355	3A0 39-40-042/43 H319373	3A0 39-40-046/43 H320178	3A0 39-40-044/43 H318495							
15	2	Skt. Schraube Hex. Screw	1.4301	DIN EN 24017-A2-70	65-01-081/15 M8x16 H78772	65-01-083/15 M8x20 H78776									
16	1	Führungsbuchse Bushing	PTFE 25% Kohle	08-01-177/23 H162714	08-01-178/23 H207154	08-01-178/23 H207154									
17	1	Führungsbuchse Ausführung -3A design -3A	PEEK	08-01-177/23 H162714	3A0 08-01-178/27 H315800										
18	1	Entlüftungstopfen Venting plug	PHT/BLACK		08-60-005/94 H175308										
19	1	O-Ring	EPDM FDA-konform	58-06-052/64 15,3x2,4 H206007	58-06-078/64 20,2x3 H121794										
20	1	Skt. Schraube Hex. Screw	1.4301	DIN EN 24017-A2-70	65-01-055/13 4xM6x12 H78750	65-01-081/15 4xM8x16 H78772									
21	1	O-Ring	EPDM FDA-konform	58-06-144/64 35x3,5 H324909	58-06-269/64 60x4 H324910	58-06-340/64 75x4,5 H324911	58-06-581/64 120x4,5 H324913	58-06-140/64 58-06-083/64 22x3,5 H319390							
22	1	O-Ring	EPDM FDA-konform	58-06-038/64 11x2,5 H320269	58-06-067/64 18x3 H320261	58-06-083/64 22x3,5 H319390	58-06-083/64 22x3,5 H319390	58-06-140/64 31,1x3,5 H320271							
23	1	Gehäusedeckel Housing lid	1.4404	000 39-01-230/47 H176062	000 39-01-138/47 H68670	000 39-01-139/47 H107248	000 39-01-144/47 H161561	000 39-01-143/47 H107251							

Ersatzteilliste: spare parts list

Membranventil fan support MSES4 FS-CU und VSM
Diaphragm valve fan support MSES4 FS-CU and PSH
1-4 Zoll / inch

APV
 SPX FLOW
 Germany

Datum:	07.07.09	07.05.12	05.03.13	18.09.14
Name:	Trytko	Trytko	Trytko	Trytko
Geprüft:	Schulz	Schulz	Schulz	Schulz
Datum:	23.10.14	26.11.15	10.06.16	11.10.16
Name:	Trytko	Trytko	Trytko	C.Keil
Geprüft:				

Blatt	5	von	6
RN 01.064.12-1			

pos. item	Menge quantity	Beschreibung description	Material	1,5" 2" 2,5" 3" 4"				
				1"	1,5"	2"	2,5"	3"
				WS-Nr. ref.-no.	WS-Nr. ref.-no.	WS-Nr. ref.-no.	WS-Nr. ref.-no.	WS-Nr. ref.-no.
20	1	Gehäusedeckel Housing lid	1.4404	000 39-01-230/43	000 39-01-138/43 H201051	000 39-01-139/43	000 39-01-144/43 H201019	000 39-01-143/43
	1	Gehäusedeckel Housing lid	1.4404	3A0 39-01-230/43 H206991	3A0 39-01-235/43 H313965	3A0 39-01-233/43 H208478	3A0 39-01-234/43 H208479	
	1	O-Ring	EPDM	58-06-157/64	58-06-300/64	58-06-345/64	58-06-520/64	
	1	O-Ring	FDA-konform	36,5X3,2 H174257	62,9x5,33 H204240	75,6x5,33 H204241	119,2x5,7 H204243	
21	1	O-Ring	FPM	58-06-157/73	58-06-300/73	58-06-345/73	58-06-520/73	
	1	O-Ring	FDA-konform	36,5X3,2 H207142	62,9x5,33 H312008	75,6x5,33 H320762	119,2x5,7	
	1	O-Ring	HNBR	58-06-157/33	58-06-300/33	58-06-345/33	58-06-520/33	
	1	O-Ring	FDA-konform	36,5X3,2 H310653	62,9x5,33 H310654	75,6x5,33 H310656	119,2x5,7 H310658	
22	1	O-Ring	VMQ	58-06-157/53	58-06-300/53	58-06-345/53	58-06-520/53	
	1	O-Ring	FDA-konform	36,5X3,2 H122830	62,9x5,33 H206352	75,6x5,33	119,2x5,7	
23	1	Skt. Schraube Hex. Screw	1.4301	65-01-055/13 4xM6x12 H78750	65-01-081/15 4xM8x16 H78772	000 15-32-052/17	000 15-32-052/17	
	1	Steuerkopf Actuator	1.4301	000 15-32-050/17 H171378	000 15-32-051/17 H171379	000 15-32-052/17 H171380	000 15-32-052/17 H171380	
	1	Steuerkopf Actuator	1.4301	000 15-32-050/13 H178155	000 15-32-051/13 H177400	000 15-32-052/13 H200827	000 15-32-052/13 H200827	
	1	Steuerkopf Actuator	1.4301	3A0 15-32-059/13 H208693	3A0 15-32-060/13 H173538	3A00 15-32-061/13 H173524	3A00 15-32-061/13 H173524	
24	1	W-Versch. schwenk. W-Union slewable	PA-1.4301		08-60-811/93 H312732			
	1	Entlüftungstopfen Venting plug	PE-HARD Yellow		08-60-005/93 H16218			
26	1	O-Ring	NBR		58-06-297/83 H173930			
	1	O-ring	70-75 Shore A		15-28-940/12 H170196			
27	1	Zentrierscheibe Centering nut	1.4301		65-50-105/15 H112376			
	1	Skt. Mutter Hex. Nut	1.4301					
29	1	Schaltlocke Operating cam	1.4523	08-52-290/97 H173086				
	1	Operating cam			08-52-291/97 H173087			

Ersatzteilliste: spare parts list

Membranventil fan support MSES4 FS-CU und VSM Diaphragm valve fan support MSES4 FS-CU and PSH 1-4 Zoll / inch

Datum:		07.07.09	07.05.12	05.03.13	18.09.14
Name:	Trytko	Trytko	Trytko	Trytko	Trytko
Geprüft:	Schulz	Schulz	Schulz	Schulz	Schulz

Datum:		23.10.14	26.11.15	10.06.16	11.10.16
Name:	Trytko	Trytko	Trytko	Trytko	C-Keil
Geprüft:					



Blatt		6	von	6
RN 01.064.12-1				

pos. item	Menge quantity	Beschreibung description	Material	1"	1,5"	2"	2,5"	3"	4"
				WS-Nr. ref.-no.	WS-Nr. ref.-no.	WS-Nr. ref.-no.	WS-Nr. ref.-no.	WS-Nr. ref.-no.	WS-Nr. ref.-no.
30	1	VSM Gehäuse Proximity switch holder housing	Vestamid						
31	4	Skt. Schraube Hex. Screw DIN EN 24017 M8x16 -A2-70	1.4301						
32	1	Control-Unit CU41-S-Direckt Connect	PA 6.6 GF 30 schwarz						
33	1	CU4-S-Adapter CU4-S-adapter	PA 6.6 GF 30 schwarz						

15-33-932/93 H173931
65-01-081/15 H78772
08-45-100/93 H320460
08-48-600/93 H320474

Dichtungssatz Standardausführung / seal kit standard design									
Pos. 2, 4, 4.1, 5, 8, 14, 16, 18, 19, 21, 28 nur im Kompletten Dichtungssatz erhältlich / Item 2, 4, 4.1, 5, 8, 14, 16, 18, 19, 21, 28 available as complete seal kits only									
1	Dichtungssatz Seal kit		TFM / FPM	58-36-933/00	58-36-934/00 H334334	58-36-935/00	58-36-936/00 H336286	58-36-939/00	58-32-938/00
1	Dichtungssatz Seal kit		TFM / EPDM	58-36-933/01 H329275	58-36-934/01 H329276	58-36-935/01 H327556	58-36-936/01 H332837	58-36-939/01 H333190	58-36-938/01
1	Dichtungssatz Seal kit		TFM / VMQ	58-36-933/02	58-36-934/02	58-36-935/02	58-36-936/02	58-36-939/02	58-36-938/02
1	Dichtungssatz Seal kit		TFM / HNBR	58-36-933/06	58-36-934/06 H328836	58-36-935/06 H331999	58-36-936/06 H336287	58-36-939/06	58-36-938/06

Dichtungssatz Ausführung -3A / seal kit design -3A									
Pos. 2, 4, 4.1, 5, 8, 14, 16, 18, 19, 21, 28 nur im kompletten Dichtungssatz erhältlich / Item 2, 4, 4.1, 5, 8, 14, 16, 18, 19, 21, 28 available as complete seal kits only									
1	Dichtungssatz Seal kit		TFM / FPM	3A0 58-36-933/00	3A0 58-36-934/00	3A0 58-36-935/00	3A0 58-36-936/00	3A0 58-36-939/00	3A0 58-32-938/00
1	Dichtungssatz Seal kit		TFM / EPDM	3A0 58-36-933/01	3A0 58-36-934/01	3A0 58-36-935/01	3A0 58-36-936/01	3A0 58-36-939/01	3A0 58-36-938/01
1	Dichtungssatz Seal kit		TFM / VMQ	3A0 58-36-933/02	3A0 58-36-934/02	3A0 58-36-935/02	3A0 58-36-936/02	3A0 58-36-939/02	3A0 58-36-938/02
1	Dichtungssatz Seal kit		TFM / HNBR	3A0 58-36-933/06	3A0 58-36-934/06	3A0 58-36-935/06	3A0 58-36-936/06	3A0 58-36-939/06	3A0 58-36-938/06

Ersatzteilliste: spare parts list

**Steuerkopf SW4
Actuator SW4**

Datum:	11/08	12/09	27.01.15	10.7.17
Name:	Peters	Peters	Trytko	Keil
Geprüft:				

APV
SPX FLOW
Germany

Blatt	1	von	1
RN 01.054.86			

pos.	Menge quantity	Beschreibung description	Ø 74	Ø 110	Ø 165
1	1	Steuerkopf kpl. Feder/Luft - matt glänzend Actuator cpl. Spring/air satin finish	WS-Nr. ref.-no. 15-32-050/17 H171378	WS-Nr. ref.-no. 15-32-051/17 H171379	WS-Nr. ref.-no. 15-32-052/17 H171380
1	1	Steuerkopf kpl. Feder/Luft - 3A-blank Actuator cpl. Spring/air 3A bright	3A0 15-32-059/13 H208693	3A0 15-32-060/13 H173538	3A0 15-32-061/13 H173524
1	1	Steuerkopf kpl. Luft/Luft - matt glänzend Actuator cpl. air/air satin finish	15-32-085/17 H209592	15-32-086/17 H209203	15-32-087/17 H208733
1	1	Steuerkopf kpl. Luft/Luft - 3A-blank Actuator cpl. air/air 3A bright	3A0 15-32-057/13 H208690	3A0 15-32-065/13 H208772	3A0 15-32-066/13 H208773
2	2	Schraube Dichtung Seal screw	15-28-840/93 H170200		
3	2	V-Dichtung V-seal	58-32-010/83 H171060		
4	2	O-Ring O-ring	58-06-124/83 H171059		
5	1	Entlüftungstopfen G-1/8" Venting Plug G-1/8"	08-60-005/93 H16218		
6	1	W-Verschraubung G-1/8" 6Ømm schwenkbar W-Union G-1/8" / 6Ømm slewable	08-60-750/93 H208825		
6	1	W-Verschraubung G-1/8"1/4" OD 6Ømm sch. W-Union G-1/8" / 1/4" OD 6Ømm slewable	08-60-811/93 H312732		

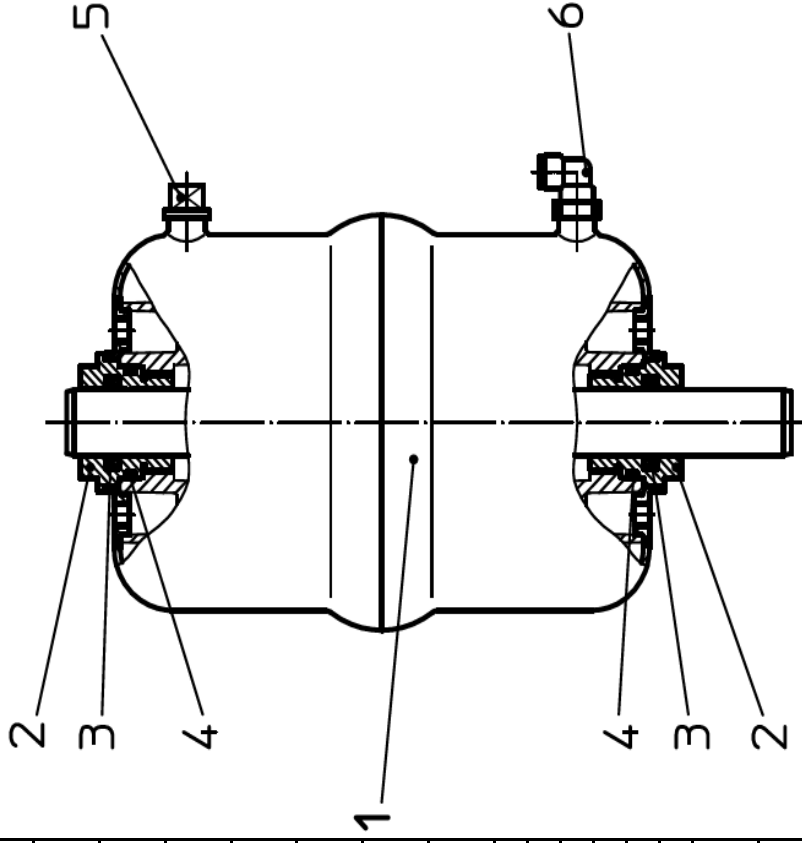

Weitergabe sowie Vervielfältigung dieser Unterlage, Verwertung und Mitteilung ihres Inhalts nicht gestattet, soweit nicht schriftlich zugestanden. Verstößt verpflichtet zum Schadensersatz und kann strafrechtliche Folgen haben (Paragraf 18 UWG, Paragraf 106 UrhG). Eigentum und alle Rechte, auch für Patenterteilung und Gebrauchsmustereintragung, vorbehalten. SPX FLOW, Germany.

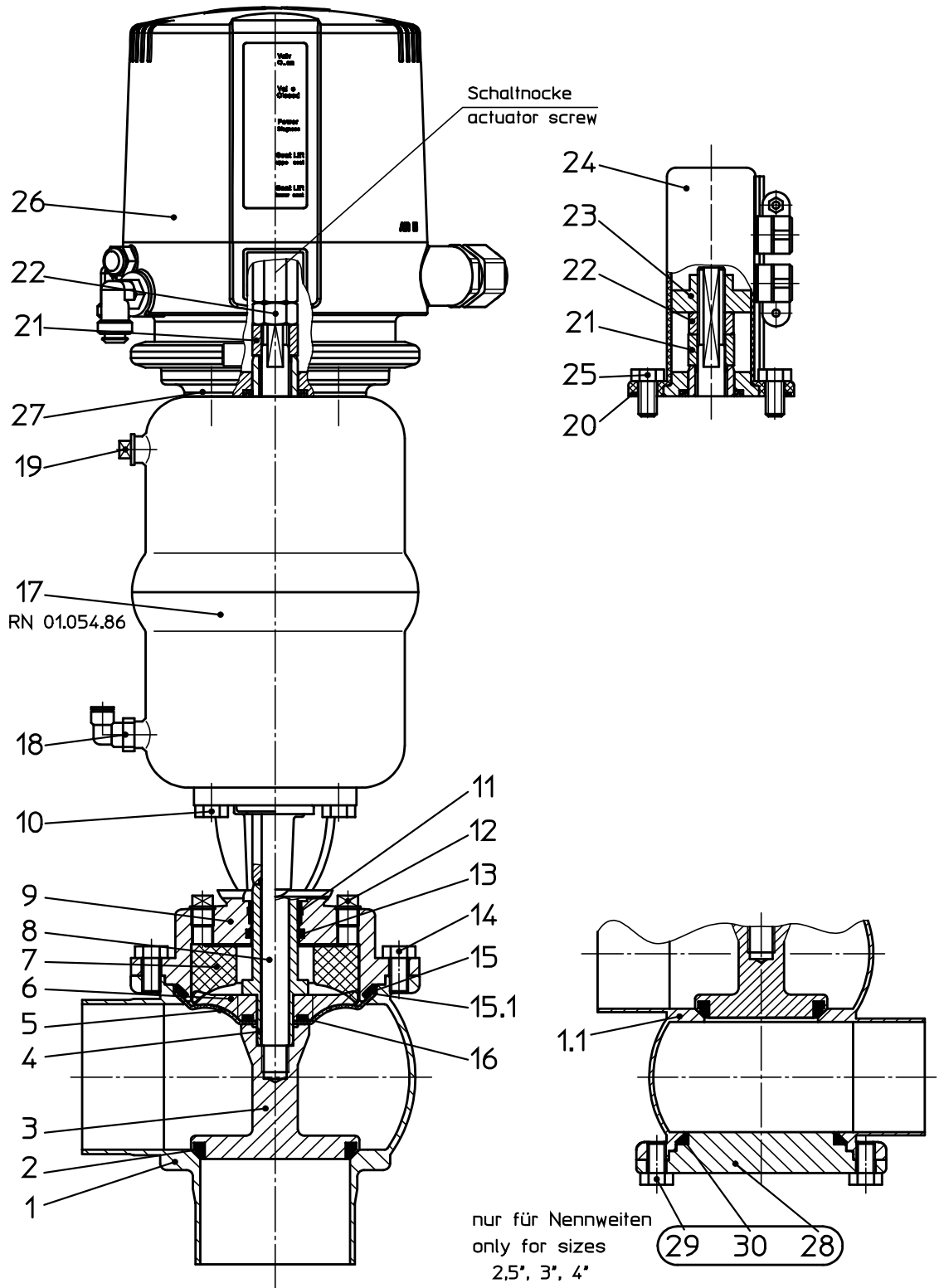

Pos. 18 und 19 nur bei Steuerkopf 3A-Ausführung (blank geschliffen)
 item. 18 and 19 only for actuator 3A-design (bright ground finish)

Datum:	02.06.08	12.03.12	28.03.14	24.09.14	10.06.16	03.07.17				
Name:	Trytko	Trytko	Trytko	Trytko	Trytko	C.Keil				
Geprüft:	Schulz	Schulz								

Ersatzteilliste: spare parts list

Membranventil fan support MS4, MSE4 FS-CU und VSM
Diaphragm valve fan support MS4, MSE4 FS-CU and PSH
 1-4 Zoll / inch



SPX FLOW
Germany

Blatt 1 von 6

RN 01.064.9-2

Ersatzteilliste: spare parts list

Membranventil fan support MS4, MSE4 FS-CU und VSM

Diaphragm valve fan support MS4, MSE4 FS-CU and PSH

1-4 Zoll / inch

pos. item	Menge quantity	Beschreibung description	Material	1"	1,5"	2"	2,5"	3"	4"	
				WS-Nr. ref.-no.	WS-Nr. ref.-no.	WS-Nr. ref.-no.	WS-Nr. ref.-no.	WS-Nr. ref.-no.	WS-Nr. ref.-no.	
1	1	Gehäuse Housing M41 1+2S blank geschliffen / bright ground	1.4404	3A0 39-41-800/43 H205535	3A0 39-41-801/43 H205536	3A0 39-41-802/43 H205537	3A0 39-41-803/43 H205538	3A0 39-41-804/43 H205539	3A0 39-41-805/43 H205540	
	1	Gehäuse Housing M41 1+2S matt-glänzend / satin finish	1.4404	3A0 39-41-800/47 H321875	3A0 39-41-801/47 H319773	3A0 39-41-802/47 H321110	3A0 39-41-803/47 H321876	3A0 39-41-804/47 H320166	3A0 39-41-805/47 H321877	
	1	Gehäuse Housing M42 1+2+3S blank geschliffen / bright ground	1.4404	3A0 39-42-800/43 H205545	3A0 39-42-801/43 H205546	3A0 39-42-802/43 H205547	3A0 39-42-803/43 H205548	3A0 39-42-804/43 H205549	3A0 39-42-805/43 H205550	
	1	Gehäuse Housing M42 1+2+3S matt-glänzend / satin finish	1.4404	3A0 39-42-800/47 H321426	3A0 39-42-801/47 H321109	3A0 39-42-802/47 H321108	3A0 39-42-803/47 H321878	3A0 39-42-804/47 H319774	3A0 39-42-805/47 H321879	
	1	Gehäuse Housing ME41 1+2S blank geschliffen / bright ground	1.4404	3A0 39-45-320/43	3A0 39-45-420/43 H326101	3A0 39-45-470/43	3A0 39-45-520/43	3A0 39-45-570/43	3A0 39-45-670/43	
	1	Gehäuse Housing ME41 1+2S matt-glänzend / satin finish	1.4404	3A0 39-45-320/47	3A0 39-45-420/47 H326064	3A0 39-45-470/47 H321107	3A0 39-45-520/47	3A0 39-45-570/47	3A0 39-45-670/47	
	1.1	Gehäuse Housing ME42 1+2+3S blank geschliffen / bright ground	1.4404	3A0 39-46-320/43	3A0 39-46-420/43 H323150	3A0 39-46-470/43	3A0 39-46-520/43	3A0 39-46-570/43	3A0 39-46-670/43	
	1	Gehäuse Housing ME42 1+2+3S matt-glänzend / satin finish	1.4404	3A0 39-46-320/47	3A0 39-46-420/47	3A0 39-46-470/47	3A0 39-46-520/47	3A0 39-46-570/47	3A0 39-46-670/47	
	1	Gehäuse Housing ME43 1+2+3S blank geschliffen / bright ground	1.4404	3A0 39-47-320/43	3A0 39-47-420/43 H326938	3A0 39-47-470/43 H316545	3A0 39-47-520/43	3A0 39-47-570/43	3A0 39-47-670/43	
	1	Gehäuse Housing ME43 1+2+3S matt-glänzend / satin finish	1.4404	3A0 39-47-320/47	3A0 39-47-420/47 H326938	3A0 39-47-470/47 H321106	3A0 39-47-520/47	3A0 39-47-570/47 H322810	3A0 39-47-670/47	
	1	Gehäuse Housing ME44 1+2+3+4S blank geschliffen / bright ground	1.4404	3A0 39-48-320/43	3A0 39-48-420/43 H327136	3A0 39-48-470/43	3A0 39-48-520/43	3A0 39-48-570/43	3A0 39-48-670/43	
	1	Gehäuse Housing ME44 1+2+3+4S matt-glänzend / satin finish	1.4404	3A0 39-48-320/47	3A0 39-48-420/47	3A0 39-48-470/47 H321104	3A0 39-48-520/47	3A0 39-48-570/47	3A0 39-48-670/47	
	2	1	Tellerdichtung Seat seal	EPDM FDA-konform	58-33-293/93 H77442	58-33-393/93 H77467	58-33-443/93 H77491	58-33-493/93 H77515	58-33-568/93 H77561	58-33-643/93 H77586
		1	Tellerdichtung Seat seal	FPM FDA-konform	58-33-293/73 H77441	58-33-393/73 H77466	58-33-443/73 H77490	58-33-493/73 H77514	58-33-568/73 H77560	58-33-643/73 H77585
1		Tellerdichtung Seat seal	HNBR FDA-konform	58-33-293/33 H170176	58-33-393/33 H166676	58-33-443/33 H166085	58-33-493/33 H166678	58-33-568/33 H166679	58-33-643/33 H166682	
1		Tellerdichtung Seat seal	VMQ FDA-konform	58-33-293/13 H77440	58-33-393/13 H77465	58-33-443/13 H77489	58-33-493/13 H77513	58-33-568/13 H77559	58-33-643/13 H77584	

Datum:	02.06.08	12.03.12	28.03.14	24.09.14
Name:	Trytko	Trytko	Trytko	Trytko
Geprüft:	Schulz	Schulz		

Datum:	10.06.16	03.07.17
Name:	Trytko	C. Keil
Geprüft:		

Blatt 2 von 6

RN 01.064.9-2



Weitergabe sowie Vervielfältigung dieser Unterlage, Verwertung und Mitteilung ihres Inhalts nicht gestattet, soweit nicht schriftlich zugestanden. Verstoß verpflichtet zum Schadensersatz und kann strafrechtliche Folgen haben (Paragraf 18 UWG, Paragraf 106 UrhG). Eigentum und alle Rechte, auch für Patenterteilung und Gebrauchsmusterteilung, vorbehalten. SPX FLOW, Germany

Ersatzteilliste: spare parts list

Membranventil fan support MS4, MSE4 FS-CU und VSM Diaphragm valve fan support MS4, MSE4 FS-CU and PSH 1-4 Zoll / inch

pos. item	Menge quantity	Beschreibung description	Material	1"	1,5"	2"	2,5"	3"	4"
				WS-Nr. ref.-no.	WS-Nr. ref.-no.	WS-Nr. ref.-no.	WS-Nr. ref.-no.	WS-Nr. ref.-no.	WS-Nr. ref.-no.
3	1	Schaft unten Lower valve shaft	1.4404	3A0 39-22-320/43 H320589	3A0 39-22-420/43 H206855	3A0 39-22-470/43 H320590	3A0 39-22-520/43 H207027	3A0 39-22-570/43 H207028	3A0 39-22-670/43 H207029
4	1	Schaft oben Upper valve shaft	1.4301	39-22-070/12 H318486	39-22-071/12 H318487	39-22-072/12 H318488	39-22-072/12 H318488	39-22-072/12 H318488	39-22-074/12 H318490
5	1	Membrane	TFM	58-23-050/23 H318545	58-23-051/23 H318544	58-23-051/23 H318544	58-23-052/23 H318543	58-23-052/23 H318543	58-23-054/23 H318541
6	1	Stern Star	1.4301	08-48-520/12 H320414	08-48-521/12 H320249	08-48-521/12 H320249	08-48-522/12 H319397	08-48-522/12 H319397	08-48-524/12 H320332
7	1	Membranunterstützung Fan support	Ryton R4-XT	08-48-510/93 H318532	08-48-511/93 H318533	08-48-511/93 H318533	08-48-512/93 H318534	08-48-512/93 H318534	08-48-514/93 H318536
8	1	Zugstange Guide rod	1.4305	39-23-080/12 H202599	39-23-129/12 H320621	39-23-129/12 H320621	39-23-083/12 H202608	39-23-083/12 H202608	39-23-130/12 H320577
9	1	Laterne Ausf. 3A-blank geschl. design 3A-bright ground fin.	1.4404	3A0 39-40-040/43 H320458	3A0 39-40-041/43 H320355	3A0 39-40-041/43 H320355	3A0 39-40-042/43 H319373	3A0 39-40-046/43 H320178	3A0 39-40-044/43 H318495
9	1	Laterne Ausführung matt-gl. design satin finish	1.4404	39-40-040/47 H318491	39-40-041/47 H318492	39-40-041/47 H318492	39-40-042/47 H318493	39-40-046/47 H318549	39-40-044/47 H320578
10	4	Skt. Schraube Hex. Screw	1.4301	65-01-081/15 M8x16 H78772	65-01-081/15 M8x16 H78772	65-01-081/15 M8x16 H78772	65-01-083/15 M8x20 H78776	65-01-083/15 M8x20 H78776	65-01-130/15 8xM10x16 H78806
11	1	Führungsbuchse Bushing	PEEK	000 08-01-177/23 H162714	000 08-01-177/23 H162714	000 08-01-177/23 H162714	3A0 08-01-178/27 H315800	3A0 08-01-178/27 H315800	3A0 08-01-178/27 H315800
12	2	Entlüftungstopfen Venting plug	PHT/BLACK	58-06-052/64 15,3x2,4 H206007	58-06-052/64 15,3x2,4 H206007	58-06-052/64 15,3x2,4 H206007	58-06-078/64 20,2x3 H121794	58-06-078/64 20,2x3 H121794	58-06-078/64 20,2x3 H121794
13	1	O-Ring	EPDM	65-01-055/13 4xM6x12 H78750	65-01-055/13 4xM6x12 H78750	65-01-055/13 4xM6x12 H78750	65-01-081/15 4xM8x16 H78772	65-01-081/15 4xM8x16 H78772	65-01-130/15 8xM10x16 H78806
15	1	O-Ring gültig bis Mai 2009 valid until May 2009	EPDM	58-06-154/64 35x2,5 H320272	58-06-154/64 35x2,5 H320272	58-06-154/64 35x2,5 H320272	58-06-347/64 76x3,5 H319391	58-06-347/64 76x3,5 H319391	58-06-580/64 120x3,5 H320274
15.1	1	O-Ring gültig ab Mai 2009 valid from May 2009	EPDM	58-06-144/64 35x3,5 H324909	58-06-144/64 35x3,5 H324909	58-06-144/64 35x3,5 H324909	58-06-340/64 75x4,5 H324911	58-06-340/64 75x4,5 H324911	58-06-581/64 120x4,5 H324913
16	1	O-Ring	EPDM	58-06-038/64 11x2,5 H320269	58-06-038/64 11x2,5 H320269	58-06-038/64 11x2,5 H320269	58-06-083/64 22x3,5 H319390	58-06-083/64 22x3,5 H319390	58-06-140/64 31,1x3,5 H320271



Blatt 3 von 6
RN 01.064.9-2

Datum:	02.06.08	12.03.12	18.07.13	28.03.14
Name:	Trytko	Trytko	Trytko	Trytko
Geprüft:	Schulz	Schulz	Schulz	
Datum:	24.09.14	10.06.16	03.07.17	
Name:	Trytko	Trytko	C. Keil	
Geprüft:				

Weitergabe sowie Vervielfältigung dieser Unterlage, Verwertung und Mitteilung ihres Inhalts nicht gestattet, soweit nicht schriftlich zugestanden. Verstößt verpflichtet zum Schadensersatz und kann strafrechtliche Folgen haben (Paragraf 18 UWG, Paragraf 106 UrhG). Eigentum und alle Rechte, auch für Patenterteilung und Gebrauchsmustereintragung, vorbehalten. SPX FLOW, Germany

Ersatzteilliste: spare parts list

Membranventil fan support MS4, MSE4 FS-CU und VSM

Diaphragm valve fan support MS4, MSE4 FS-CU and PSH

1-4 Zoll / inch

Datum:	02.06.08	12.03.12	28.03.14	24.09.14
Name:	Trytko	Trytko	Trytko	Trytko
Geprüft:	Schulz	Schulz		
Datum:	03.07.17			
Name:	C. Keil			
Geprüft:				

Blatt 4 von 6	
RN 01.064.9-2	

APV		SPX FLOW		Germany	
-----	--	----------	--	---------	--

pos. item	Menge quantity	Beschreibung description	Material	1"	1,5"	2"	2,5"	3"	4"
				WS-Nr. ref.-no.	WS-Nr. ref.-no.	WS-Nr. ref.-no.	WS-Nr. ref.-no.	WS-Nr. ref.-no.	WS-Nr. ref.-no.
17	1	Steuerkopf Actuator Ausf. 3A-blank geschl. design 3A-bright ground fin.	1.4301	3A0 15-32-059/13 H208693	3A0 15-32-060/13 H173538	3A0 15-32-061/13 H173524			
	1	Steuerkopf Actuator Ausführung matt-gl. design satin finish	1.4301	000 15-32-050/17 H171378	000 15-32-051/17 H171379	000 15-32-052/17 H171380			
18	1	W-Verschraubung schwenkbar W-Union slewable G1/8" 1/4" OD	PA-14301		08-60-811/93 H312732				
19	1	Entlüftungsstopfen Venting plug G1/8"	PE-Hard Yellow		08-60-005/93 H16218				
20	1	O-Ring O-ring OR 66x2	NBR 70-75 Shore A		58-06-297/83 H173930				
21	1	Zentrierscheibe Centering nut	1.4301		15-28-940/12 H170196				
22	1	Skt. Mutter Hex. Nut DIN EN ISO 10511 M12-A2	1.4301		65-50-105/15 H112376				
23	1	Schaltnocke Operating cam	1.4523	08-52-290/97 H173086	08-52-291/97 H173087				
24	1	VSM Gehäuse Proximity switch holder housing	Vestamid		15-33-932/93 H173931				
25	4	Skt. Schraube Hex. Screw DIN EN 24017 M8x16 -A2-70	1.4301		65-01-081/15 H78772				
26	1	Control-Unit Control-Unit CU41-S-Direkt Connect	PA 6.6 GF 30 schwarz		08-45-100/93 H320460				
27	1	CU4-S-Adapter CU4-S-adapter	PA 6.6 GF 30 schwarz		08-48-600/93 H320474				
28	1	Gehäusedeckel Housing screw	1.4404		3A0 39-01-233/43 H208478	3A0 39-01-234/43 H208479			
29	4	Skt. Schraube Hex. screw DIN EN 24017 M8x16-A2-70	1.4301		65-01-081/15 M8x16 H78772				
30	1	O-Ring	EPDM		58-06-345/64				58-06-520/64
	1	O-Ring	FDA-konform FPM		75,6x5,33 H204241				119,2x5,7 H204243
					58-06-345/73				58-06-520/73
					75,6x5,33 H320762				119,2x5,7

Ersatzteilliste: spare parts list

Membranventil fan support MS4, MSE4 FS-CU und VSM
Diaphragm valve fan support MS4, MSE4 FS-CU and PSH
1-4 Zoll / inch

Datum:		02.06.08	12.03.12	28.03.14	24.09.14
Name:	Trytko	Trytko	Trytko	Trytko	Trytko
Geprüft:	Schulz	Schulz			
Datum:		10.06.16	03.07.17		
Name:	Trytko	C. Keil			
Geprüft:					
Blatt 5 von 6					
RN 01.064.9-2					

--	--	--	--	--	--

pos. item	Menge quantity	Beschreibung description	Material	1"	1,5"	2"	2,5"	3"	4"
				WS-Nr. ref.-no.	WS-Nr. ref.-no.	WS-Nr. ref.-no.	WS-Nr. ref.-no.	WS-Nr. ref.-no.	WS-Nr. ref.-no.
30	1	O-Ring	HNBR				58-06-345/33		
		O-ring	FDA-konform				75,6x5,33 H310656		
	1	O-Ring	VMQ				58-06-345/53		
		O-ring	FDA-konform				75,6x5,33		

Dichtungssatz MS4 Ausführung -3A / seal kit MS4 design -3A gültig bis Mai 2009 / valid until May 2009									
Pos. 2, 5, 11, 13, 15, 16, 22 nur im kompletten Dichtungssatz erhältlich / Item 2, 5, 11, 13, 15, 16, 22 available es complete seal kits only									
1	1	Dichtungssatz Seal kit	TFM / FPM	3A0 58-36-780/00	3A0 58-36-781/00	3A0 58-36-782/00	3A0 58-36-783/00	3A0 58-36-786/00	3A0 58-36-785/00
		Dichtungssatz Seal kit	TFM / EPDM	3A0 58-36-780/01 H322881	3A0 58-36-781/01 H322882	3A0 58-36-782/01 H322883	3A0 58-36-783/01 H322884	3A0 58-36-786/01 H322886	3A0 58-36-785/01 H322887
	1	Dichtungssatz Seal kit	TFM / VMQ	3A0 58-36-780/02	3A0 58-36-781/02	3A0 58-36-782/02	3A0 58-36-783/02	3A0 58-36-786/02	3A0 58-36-785/02
	1	Dichtungssatz Seal kit	TFM / HNBR	3A0 58-36-780/06	3A0 58-36-781/06	3A0 58-36-782/06	3A0 58-36-783/06	3A0 58-36-786/06	3A0 58-36-785/06

Dichtungssatz MS4 Ausführung -3A / seal kit MS4 design -3A gültig ab Mai 2009 / valid from May 2009									
Pos. 2, 5, 11, 13, 15.1, 16, 22 nur im kompletten Dichtungssatz erhältlich / Item 2, 5, 11, 13, 15.1, 16, 22 available es complete seal kits only									
2	1	Dichtungssatz Seal kit	TFM / FPM	3A0 58-36-920/00	3A0 58-36-921/00	3A0 58-36-922/00	3A0 58-36-923/00	3A0 58-36-926/00	3A0 58-32-925/00
		Dichtungssatz Seal kit	TFM / EPDM	3A0 58-36-920/01 H324951	3A0 58-36-921/01 H324952	3A0 58-36-922/01 H324953	3A0 58-36-923/01 H324954	3A0 58-36-926/01 H324957	3A0 58-36-925/01 H324956
	1	Dichtungssatz Seal kit	TFM / VMQ	3A0 58-36-920/02	3A0 58-36-921/02	3A0 58-36-922/02	3A0 58-36-923/02	3A0 58-36-926/02	3A0 58-36-925/02
	1	Dichtungssatz Seal kit	TFM / HNBR	3A0 58-36-920/06	3A0 58-36-921/06	3A0 58-36-922/06	3A0 58-36-923/06	3A0 58-36-926/06	3A0 58-36-925/06

APV DELTA MS4

DIAPHRAGM VALVE WITH "FAN SUPPORT"

SPXFLOW

SPX FLOW

Design Center

Gottlieb-Daimler-Straße 13
D-59439 Holzwickede, Germany
P: (+49) (0) 2301-9186-0
F: (+49) (0) 2301-9186-300

SPX FLOW

Production

Stefana Rolbieskiego 2
PL- Bydgoszcz 85-862, Poland
P: (+48) 52 566 76 00
F: (+48) 52 525 99 09

SPX FLOW reserves the right to incorporate the latest design and material changes without notice or obligation.

Design features, materials of construction and dimensional data, as described in this manual, are provided for your information only and should not be relied upon unless confirmed in writing. Please contact your local sales representative for product availability in your region. For more information visit www.spxflow.com.

ISSUED 10/2018 - Translation of Original Manual
COPYRIGHT ©2018 SPX FLOW, Inc.

Scan for MS4 Valve
Maintenance Video

