

APV DELTA SVS1F DN 125-250

BUTTERFLY VALVE

FORM NO.: H201570 REVISION: UK-5

READ AND UNDERSTAND THIS MANUAL PRIOR TO OPERATING OR SERVICING THIS PRODUCT.

Scan for SV1/SVS1F Valve
Maintenance Video



We,

DESIGN CENTER/MANUFACTURER: SPX Flow Technology Germany GmbH
Gottlieb-Daimler-Str. 13, D-59439 Holzwickede

MANUFACTURING FACILITY: SPX Flow Technology Poland sp. z o.o.
Rolbieskiego 2, 85-862 Bydgoszcz, Poland

AUTHORIZED REPRESENTATIVE: SPX Flow Europe Ltd.
(for UKCA) Building A, Compass House, Manor Royal
Crawley, RH10 9PY

declare under our sole responsibility that the

APV double seal and double seat valves of the series
SD4, SDT4, SDU4, SDMS4, SDMSU4, SDTMS4, SWcip4, DSV, DA4, DA4 DPF, D4 SL, DU4
SL, DT4 SL, DP4 SL, D4, DA3, DA3SLD, DE3, DEU3, DET3, DKR2, DKRT2, DKRH2

APV butterfly valves of the series SV1, SVS1F, SV2, SVS2F, SVL, SVSL, SVE, SVSE

APV ball valves of the series BLV1

APV single seat, diaphragm and spring loaded valves of the series
S2, SW4, SWhp4, SW4DPF, SWmini4, SWT4, SWS4, MF4, MS4, MSP4, AP/T1, CPV, RG4,
RG4DPF, RGMS4, RGE4, RGE4DPF, RGEMS4, PR2, PRD2, SI2, UF/R3, UF/R4, VRA/H

and the valve manifolds installed thereof

meet the requirements of the Machinery Directive 2006/42/EC
& EN ISO 12100-2010, DIN EN ISO 14159-2008-07, DIN EN 1672-2-2009-07.

Holzwickede, November 2022



Dr.-Ing. Behdad Ariatabar, Design Center Lead - Valves

meet the requirements of the Supply of Machinery (Safety) Regulations 2008 No. 1597
& BS harmonized standards.

Crawley, November 2022

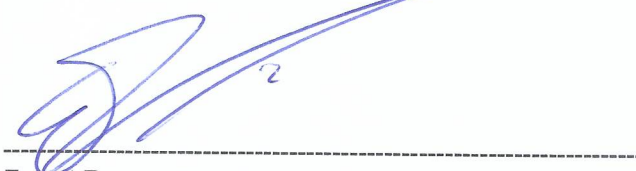

Ewout Roozendaal, Director Global Pricing

Content	Page
1. General Terms	2
2. Safety Instructions	2 - 3
3. Intended Use	3
4. Mode of Operation	4
4.1. General terms	
5. Auxiliary Equipment	5 - 7
5.1. Valve position indication - actuated valve	
5.2. Valve position indication - manually operated valve	
5.3. Control Unit	
5.4. Adapter for Control Unit	
5.4.1. Adapter for Control Unit	
5.5. Turning actuator for Control Unit	
6. Cleaning	8
6.1. Cleaning recommendation	
7. Installation	8
7.1. Welding instructions	
8. Dimensions / Weights	9
9. Technical Data	10
9.1. General terms	
9.2. Compressed air quality	
9.3. Table: tightening torque, pneumatic air consumption, kvs-values	
10. Materials	11
11. Maintenance	12
12. Service Instructions	13 - 15
12.1. Dismantling from the line system	
12.2. Disassembly of actuating device	
12.3. Dismantling of inner parts	
12.4. Replacement of seals	
12.5. Installation of seals and bearing bushes	
12.6. Installation of actuating device	
12.7. Installation of proximity switches	
13. Spare Parts Lists	16
(see attachment)	
SVS1F - NC DN 125 - 250	- RN 01.038.020
SVS1F - M DN 125 - 250	- RN 01.038.021
Handle with locking device	
SVS1F - DN 125 - 250	- RN 01.038.10
Handle with locking device for valve position indication	
SVS1F - DN 125 - 250	- RN 01.038.10 - 1
Turnign actuator K-80, K-125, K-180 spring/air	- RN 01.073
Turning actuator spring/air for feedback unit	- RN 01.076

1. General Terms

This instruction manual has to be read carefully and observed by the responsible operating and service personnel.

We do not accept any liability for damage or malfunctions resulting from the non-compliance with this instruction manual.

Descriptions and data given herein are subject to technical changes.

2. Safety Instructions

The valve must only be assembled, operated, disassembled and maintained by persons who have been trained in APV valves or by SPX FLOW service team members. If necessary, contact your local SPX FLOW representative.

DANGER!



- The technical safety symbol draws your attention to important directions for operating safety. You will find it wherever the activities described are bearing health hazards or risks for persons or material assets.



- Do not reach into the open valve or into the yoke!
Risk of bruising at movable parts of the valve.



- In dismantled state there is the risk of injury by sudden valve operation.

- Regular maintenance including replacement of seals and bearing bushes must be scheduled for the valve in order to prevent leakages.



- Before any maintenance of the valve, the line system must be depressurized and discharged if possible.



- Electric and pneumatic connections must be separated.
- Observe the following Service Instructions to ensure safe maintenance of the valve.

2. Safety Instructions

**DANGER!**

Welded actuators are preloaded by spring force.

**Opening of the actuators is strictly forbidden.
Danger to life!**

Actuators which are no longer used and / or defective must be disposed in professional manner.

Defective actuators must be returned to your SPX FLOW representative for their professional disposal and free of charge for you.

Please address to your local SPX FLOW representative.

3. Intended Use

The intended use as field of application of the butterfly valve is the shut-off of pipeline sections.

Arbitrary, structural changes at the valve may affect safety as well as the intended functionality of the valve and are ***not*** permissible.

4. Mode of Operation

4.1. General terms

Use of high-quality stainless steel and seal materials to the specified requirements, the butterfly valve range DELTA SVS1F is applicable in the food and beverage industries as well as in the chemical and pharmaceutical industries.

Valves of the series DELTA SVS1F can either be operated manually or remote controlled via a pneumatic actuator. Manual operation and pneumatic actuator including add-on pieces are interchangeable.

In the standard version "NC", the pneumatic turning actuator opens the valve with compressed air.
Reset by spring force into the limit position closed.

Extension of operating time of actuated valves by pneumatic air throttle or adjusting screw in the control unit to optimize the flow behaviour and, if required, to reduce pressure hammers arising in the installation.

The butterfly valve can also be used in vacuum systems.

The valve opens and closes by turning the valve disc by 90°.

Smooth valve passage without diversion of line flow.

The opening diameter complies with the size of the inner line diameter.

5. Auxiliary Equipment

- 5.1. Valve position indication - valve with pneumatic actuator**
Proximity switches to signal the limit position of the valve disc can be installed in the yoke area if required.

We recommend to use our APV standard proximity switches.
Type: three-wire proximity switch (ref.-No. 08-60-011/93, H16223)
Operating distance: 4mm / diameter: 11mm / length: 30 mm.

Feedback complete with support and proximity switch
(ref.-No. 15-33-023/93; H32725) for a limit position.

Using a valve position indicator other than APV, we cannot accept any liability for faulty function.

- 5.2. Valve position indication - valve with manual operation**
A specific manual actuation with feedback feature is available:
Feedback of the two disc positions **open** and **closed** is possible.

5. Auxiliary Equipment

fig. 5.3.



5.3. Units with feedback switch and magnet valve for the pneumatic control of the valve for assembly on the actuator are also available in fieldbus technology. The assembly of a control unit on a pneumatic actuator is possible.

The following different designs are available:

Direct Connect	CU41-T-Direct Connect 08 - 45 - 101/93; H320461
AS-i extended 62 slaves	CU41-T-AS-i extended 08 - 45 - 111/93; H320468
DeviceNet	CU31 DeviceNet 16 - 31 - 240/93; H209422
Profibus	CU31 Profibus 08 - 45 - 001/93; H315495

5.4. Adapter for control unit (fig. 5.4.)
CU31 Profibus, CU31 Device Net

The following adapters are required to install the control unit on the SVS1F valve.

fig. 5.4.

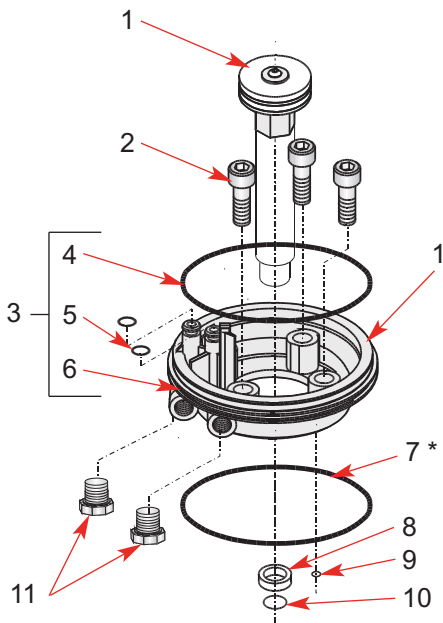

Spare parts for CU2 adapter			
Item	Pcs.	Designation	reference No. ID - No.
-	-	CU2 adapter SVS1F125-250, DKR80-100	000 08-48-417/93 H209432
1	1	CU operating cam cpl. SVS/DKR	000 08-60-780/93 H208854
2	3	cyl. screw ISO1207 M5x18-A2-7	000 08-60-760/15 H208835
3	1	adapter set	000 08-60-333/93 H310442
- 4	1	o-ring 88,62-1,78 NBR	000 58-06-387/83 H208639
- 5	2	o-ring 5,28-1,78 NBR	000 58-06-044/83 H208640
- 6	1	CU adapter for SVS,DKR	000 08-60-728/93 H208803
7*	1	o-ring 90-2 NBR * scope of supply - actuator	000 58-06-426/83 H143352
8	1	v-seal 20x28x4	000 58-32-010/83 H171060
9	1	o-ring 13,0-2,0 NBR 70	000 58-06-049/83 H208642
10	1	o-ring 11-3 NBR	000 58-06-039/83 H208632
11	2	blind plug G1/8"	000 08-60-740/93 H208815

5. Auxiliary Equipment

5.4.1. Adapter for control unit (fig. 5.4.1.) CU41-T-Direct Connect, CU41-T-AS-i extended

The following adapter is required to install the control unit CU4 on the SVS1F valve.

fig. 5.4.1.

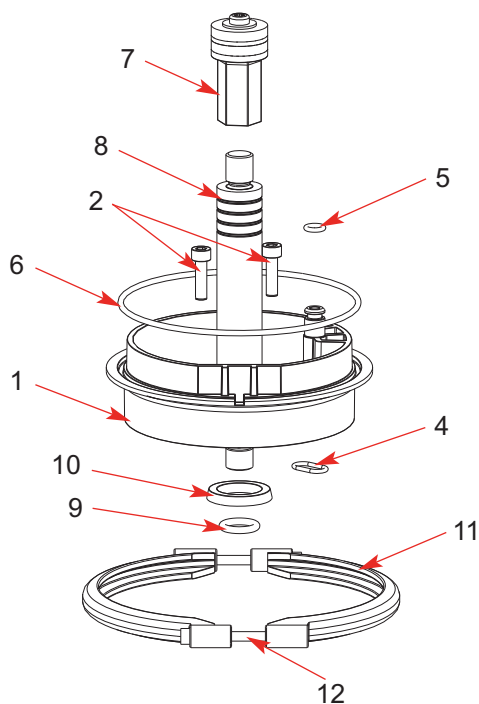

Spare Parts for CU4 T adapter			
Item	Pcs.	Designation	reference No. ID - No.
-	-	CU4 Tmax-adapter cpl.	000 08-48-611/93 H 321987
1	1	CU4 T-adapter	000 08-46-571/93 H319875
2	3	cyl. screw ISO1207 M5x16-A2-7	000 65-05-054/13 H79000
4	1	o-ring 11,11-1,78 NBR 70shore A	000 58-06-034/83 H321897
5	1	o-ring 6-2 NBR	000 58-06-059/83 H320505
6	1	o-ring 101,27-2,62	000 58-06-493/83 H148389
7	1	CU4 operating cam complete	000 08-60-900/93 H320479
8	1	CU4 SVS, DKR, K125-250 operating rod	000 08-60-906/12 H321990
9	1	o-ring 11-3 NBR	000 58-06-039/83 H208632
10	1	v-seal 20x28x4	000 58-32-010/83 H171060
11	2	CU4 clamp halves complete	000 08-46-569/93 H319873
12	2	cyl. screw ISO 4762 M4x40 inner hexagon	000 65-05-040/13 H320360

5.5. Turning actuator for control unit

- For the assembly of a control unit on the butterfly valve a special turning actuator is required. The standard turning actuator must be replaced.

Turning actuator for control unit	
DN 125 - 150 / K125 F/L-RM	000 - 15 - 37 - 106/17 H128942
DN 200 - 250 / K180 F/L-RM	000 - 15 - 37 - 103/17 H134034

6. Cleaning

6.1. Cleaning recommendation

The valve passage is cleaned by cleaning liquids during cleaning of the connected pipelines.

Depending on the degree and constituents of soiling, the cleaning liquids, times and processes must be scheduled for the individual application.

The compatibility of the individually selected cleaning processes and liquids with the respectively used seals must be verified.

7. Installation

In normal installation position, the actuator is positioned vertically to the top. Depending on the respective application, optional installation positions can, however, also be realized.

Installation can optionally be undertaken between FG1 flanges and flanges according to DIN.

Attention: Observe welding instructions!

7.1. Welding Instructions

- Welding may only be carried out by certified welders (DIN EN ISO 99606-1). (seam quality DIN EN ISO 5817).
- The welding of the mating flanges must be effected in such a way that deformation strain cannot be transferred to the housing halves.
- TIG orbital welding is the most appropriate method.
- Before welding, all sensitive parts must be removed!
Dismantle the valve core with seals from between the mating flanges.
- After welding of the mating flanges and after work at the pipelines, the corresponding parts of the installation or pipelines must be cleaned from welding residues and soiling.
If these cleaning instructions are not observed, welding residues and dirt particles can settle in the valve and cause damage or be carried over to other parts of the installation.
- Any damage resulting from the non-observance of these welding instructions is not subject to our guarantee.

8. Dimensions / Weights

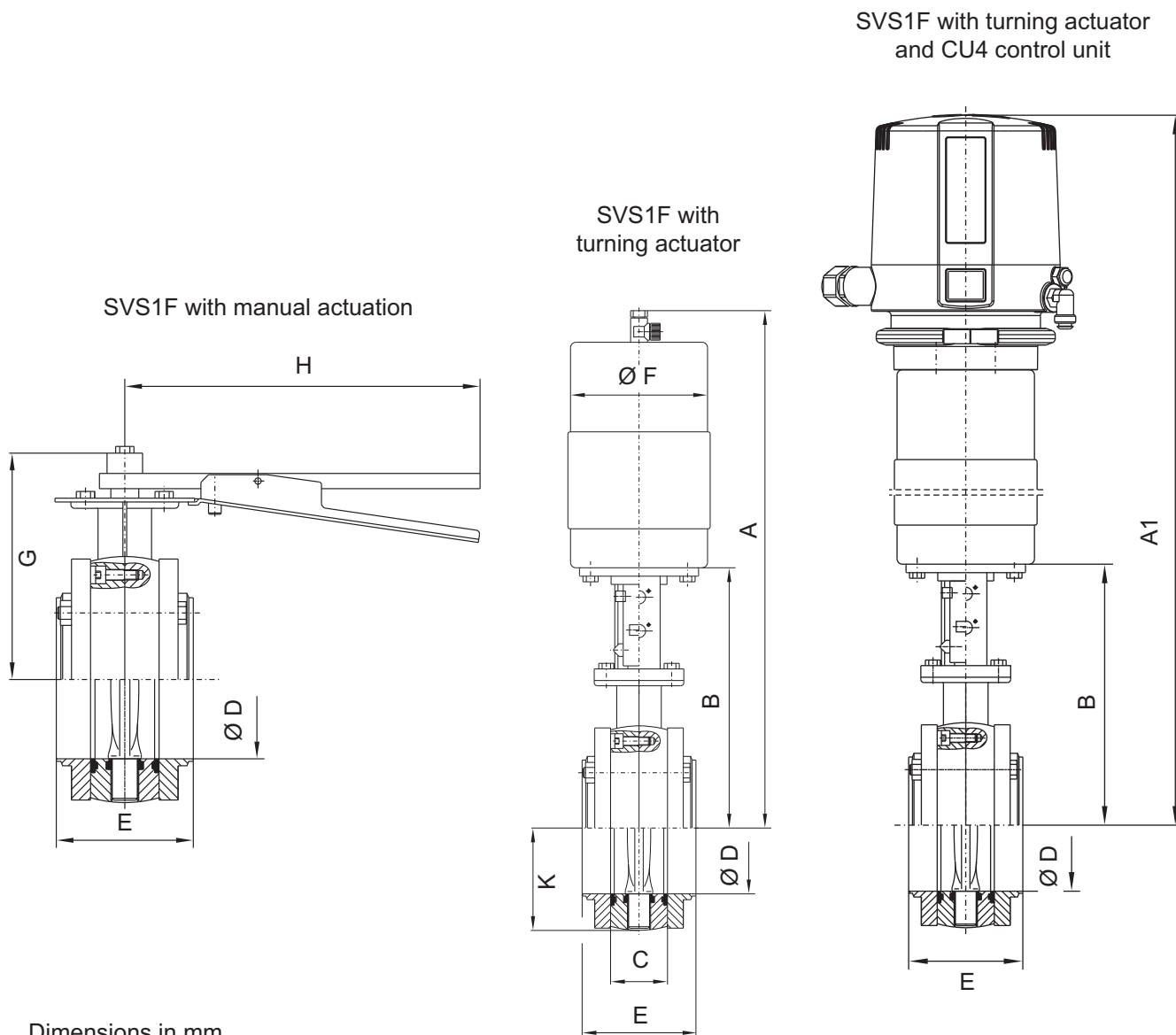

DN	A	A1	B	C	Ø D	E	Ø F	G	H	K
125	491	637	247	54	125	108	130	130	280	97
150	505	652	261	54	150	108	130	130	280	110
200	573	718	288	65	200	107	184	184	310	138
250	602	746	317	65	250	107	184	184	310	166

DN	Weights	
	manual	actuated
125	12,9	20,9
150	15,6	23,6
200	24,6	39,6
250	38,2	53,2

9. Technical Data

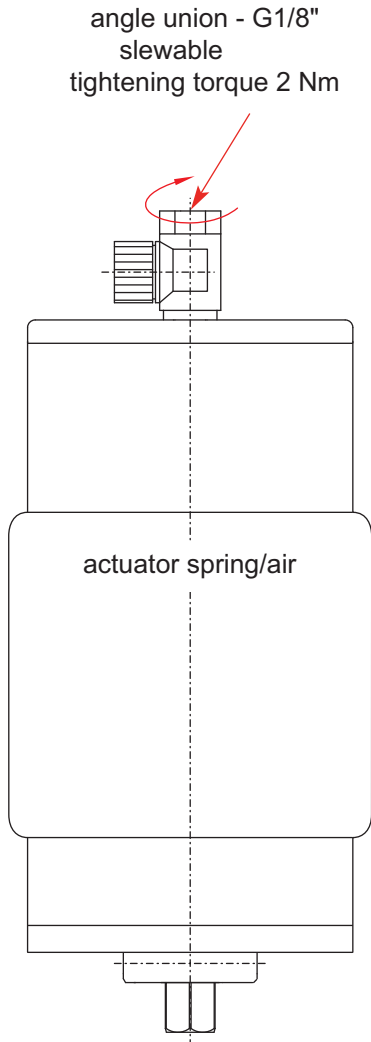

9.1. General data

- max. line pressure : **10 bar**
- max. operating temperature : **135° C EPDM, HNBR**
* VMQ, * FPM
- short-term load : **140° C EPDM, HNBR**
* VMQ, * FPM
* (no steam)
- vacuum tightness : **2 mbar**
- opening angle of butterfly valve : **90°**
min. air pressure for actuator : **6 bar**
max. air pressure for actuator : **10 bar**
- air connection (for hose) : **6 x 1**
elbow union - G1/8"
slewable : **tightening torque 2 Nm**

9.2. Compressed air quality: Quality class acc. to DIN ISO 8573-1

content of solid particles: Quality Class 3

max. size of solid particles per m³
10000 of 0,5 µm < d < 1,0 µm
500 of 1,0 µm < d < 5,0 µm

content of water:

Quality Class 3
max. dew point temperature -20 °C
For installations at lower temperatures
or at higher altitudes, additional
measures must be considered
to reduce the pressure dew point
accordingly.

content of oil:

Quality Class 1
max. 0,01 mg/m³

The oil applied must be compatible with Polyurethane elastomer materials.

9.3. DELTA SVS1F	DN	125	150	200	250
Turning actuator		K125	K125	K180	K180
Required tightening torque Md Nm		30	45	65	80
Pneumatic air consumption at 6bar V NL		5,5	5,5	11	11
Kvs - values in m ³ /h		850	1500	2500	4000

10. Materials

- valve disc	1.4404 / 1.4571 (DIN 10088)
- housing flange / mating flanges	1.4404 (DIN EN 10088)
- SV seal, flange seal standard:	EPDM
option:	HNBR, VMQ, FPM
- bearing bush	polyamide
- handle	1.4301 (DIN EN 10088)
actuator	
- yoke, turning actuator, bracket	1.4301 (DIN EN 10088)
- coupling	1.4057
- indicator	PE - hard
- spindle bearing	polyamide PA 12 / POM
- piston	polyacetal POM
- air connection	polyamide PA 6.6

11. Maintenance

Scan for SV1/SVS1F Valve
Maintenance Video

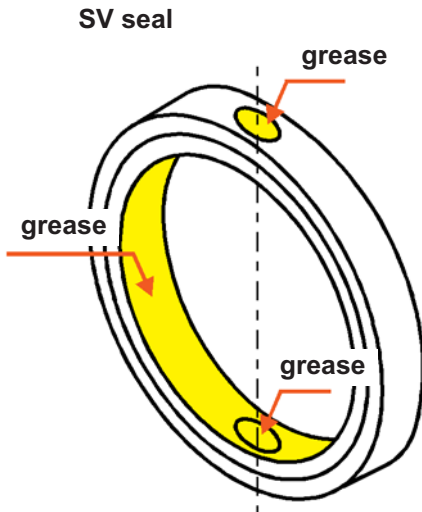

- The **maintenance intervals** depend on the application of the valve and should be determined by the operator carrying out **regular checks** of the valve.
- There are just a few wear parts in butterfly valves: the SV seal, flange seals and bearing bushes.
- It is recommended that spare seals and bearings are kept by the user. Complete seal kits for the valve service are available (see spare parts lists).
- If damaged seals are replaced, generally all seals and bearing bushes should be changed.
- Dismantling and installation of seals according to Service Instructions.
- All seals must be slightly greased before their installation. Grease SV seal according to fig.
 - especially **in** the cross bores.
- Assembly of valve and change of valve design **NC** or **NO** according to Service Instructions.
- Installation of turning actuator according to Service Instructions.
- The inner parts of the actuator are maintenance free.

Attention! Use food-grade special grease being suited for the respective seal material, only.

Recommendation:

APV assembly grease for **EPDM, FPM, HNBR and NBR**
 (0,75 kg /can - ref. No. 000 70-01-019/93; H147382)
 (60 g /tube - ref. No. 000 70-01-018/93; H147381)

or

APV assembly grease for **VMQ (Silicone)**
 (0,6 kg /can - ref. No. 000 70-01-017/93; H147380)
 (60 g /tube - ref. No. 000 70-01-016/93; H147379)

!!! Do not use grease containing mineral oil for EPDM seals !!!

!!! Do not use Silicone-based grease for VMQ seals !!!

12. Service Instructions

12.1. Dismantling from the line system



1. Shut off line pressure and drain lines if possible.
2. Separate pneumatic air line from turning actuator.
3. Release clamp connection at support of proximity switches. Pull off proximity switch.
4. Remove the flange screws (8).
5. Take butterfly valve out of the flanges.

Attention! Disassembly from the line system in **closed valve** state, only!

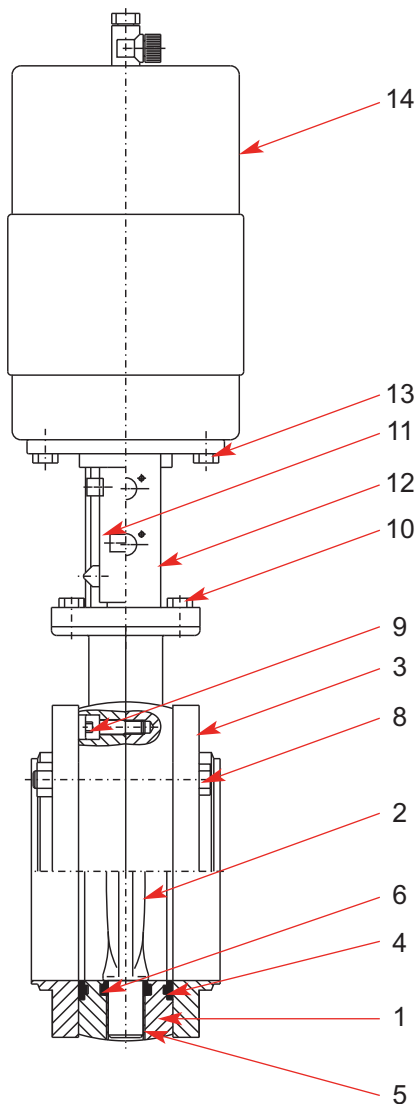

12.2. Dismantling of the actuating device

- **Design with pneumatic actuator:**
(spare parts lists RN 01.038.020)
Remove the two fastening screws (10) at the yoke (12). Lift off actuator (14) with yoke and coupling (11) to the top.

Attention! If valve position indicators are installed, see to the position of the operating cam.

- **Design with manual actuation with limit switch:**
(spare parts lists RN 01.038.10)
or
manual actuation with limit switch for valve position indication:
(spare parts lists RN 01.038.10-1)

Remove the two fastening screws (2).
Lift thrust piece (3), handle (4) and ratchet disc (1) off to the top.

12. Service Instructions

12.3. Dismantling of inner parts seal ring, bearing bushes, valve disc

- Remove all fastening screws (9) around the circumferences of the valve housing and extend the housing halves.

12.4. Replacement of seals

1. Lift the flange seals (4) out of the groove and replace them. Remove the fastening screws (9) from the valve core and part the housing halves.
2. Turn the disc (2) in the seal ring into open position.
3. Remove the bearing bushes (5) from the disc bolt.
4. By a slight pressing, the seal ring (6) is deformed in its longitudinal axis. Slide the seal ring over the short disc bolt and pull it off the disc via the long disc bolt.
5. Clean the valve disc (2).

12.5. Installation of seals and bearing bushes

Attention! Use only those assembly greases being suited for the respective seal material.

1. Provide the inner surfaces of the cross holes as well as the sealing surface and the disc bolts with a thin grease layer before installation of the parts (see chapter 11).
2. Install the seal ring (6) via the long and, then, via the short disc bolt on the disc (2).
3. Slide the bearing bushes (5) on the disc bolts. The bearing bushes must be flush with the housing halves (fig. 1).
4. Turn the valve disc in the seal ring into open position.
5. Insert the valve disc with seal ring and bearing bushes in one housing half. Fit the other housing half into it and tighten the assembly crosswise by means of the inner hexagon screws (9).

Attention! When tightening the inner hexagon screws, the valve disc must be in open position. Damage to the valve disc seal is possible in case of installation in closed position.

The bearing bushes must not protrude from the housing flange (fig. 2).

6. Fasten the mating flange (3) with the screws (8).

fig. 1

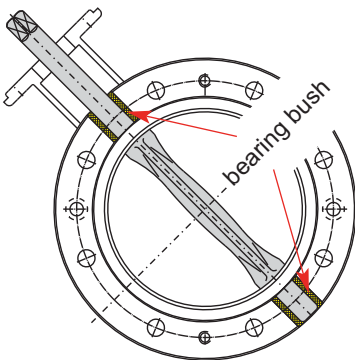
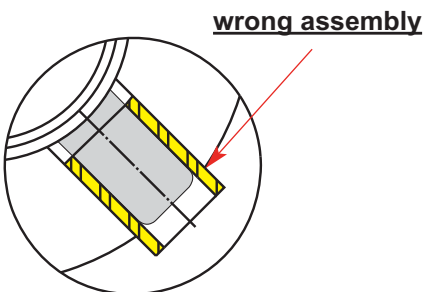

fig. 2



12. Service Instructions

12.6. Installation of the actuating device

- Observe the steps mentioned in **10.2** in reverse order.
- With manual butterfly valves, the disc and the handle are in a line.
- Observe the required valve design **NC** or **NO** during the assembly of the turning actuator.

NC = normally closed

Valve disc is closed.

Place the turning actuator with yoke and coupling on the valve and fasten the assembly with the screws **(10)**.

The **upper** operating cam must be adjusted to the **upper** yoke bore.

NO = normally open

Valve disc is open.

Place the turning actuator with yoke and coupling on the valve and fasten the assembly with the screws **(10)**.

The **lower** operating cam must be adjusted to the **lower** yoke bore.



DANGER! After installation of the turning actuator **do not** touch the open valve!
Risk of bruising at movable parts!
Risk of injury by sudden valve operation!

12.7. Installation of feedback units

- **Valve position indication OPEN:**
Installation of the feedback unit in the **lower** yoke bore.
- **Valve position indication CLOSED:**
Installation of the feedback unit in the **upper** yoke bore.
- Insert proximity switch support into the yoke bore and fasten it. Introduce the proximity switch into the support until it stops and fix it with the clamp screw.

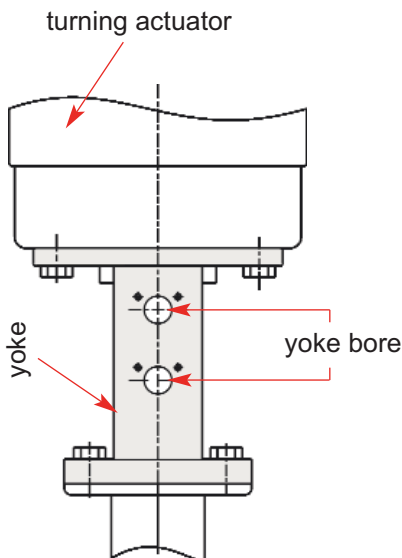

13. Spare Parts Lists

(see annex)

The reference numbers of the spare parts for the different valve designs and sizes are included in the attached spare parts drawings with corresponding lists.

Please indicate the following data to place an order for spare parts:

- number of parts required
- reference number
- designation.

subject to change

Weitergabe sowie Vervielfältigung dieser Unterlage, Verwertung und Mitteilung ihres Inhalts nicht gestattet, soweit nicht schriftlich zugestanden. Verstößt verpflichtet zum Schadensersatz und kann strafrechtliche Folgen haben (Paragraf 18 UWG, Paragraf 106 UrhG). Eigentum und alle Rechte, auch für Patenterteilung und Gebrauchsmustereintragung, vorbehalten. SPX FLOW, Germany

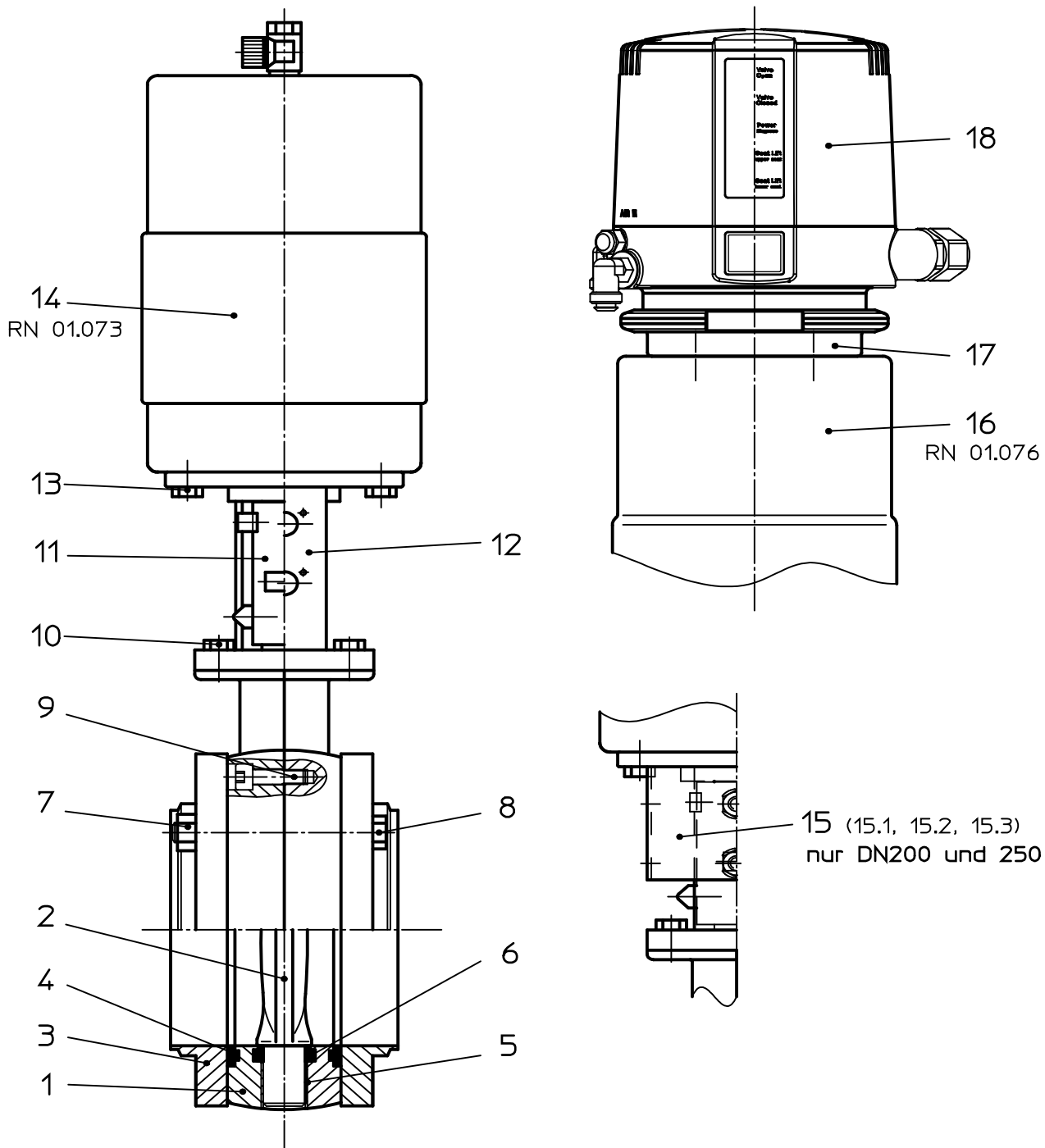

Datum:	07.02.14																			
Name:	Trytko																			
Geprüft:																				

Ersatzteilliste: spare parts list

Scheibenventil SVS1F -FZ-CU
Butterfly valve SVS1F -A-CU
DN125-250 1+2S

APV

SPX FLOW
Germany

Blatt 1 von 4

RN 01.038.020

Weitergabe sowie Vervielfältigung dieser Unterlage, Verwertung und Mitteilung ihres Inhalts nicht gestattet, soweit nicht schriftlich zugestanden. Verstoß verpflichtet zum Schadensersatz und kann strafrechtliche Folgen haben (Paragraf 18 UWG, Paragraf 106 UrhG). Eigentum und alle Rechte, auch für Patenterteilung und Gebrauchsmustererteilung, vorbehalten. SPX FLOW, Germany

Ersatzteilliste: spare parts list

Scheibenventil SVS1F -FZ-CU
Butterfly valve SVS1F -A-CU
DN125-250 1+2S

Datum:	07.02.14		
Name:	Trytko		
Geprüft:			
Datum:			
Name:			
Geprüft:			
		Blatt	2 von 4
		RN01.038.020	

item	Menge quantity	Beschreibung description	Material	DN125	150	200	250	WS-Nr. ref.-no.	WS-Nr. ref.-no.	WS-Nr. ref.-no.
				WS-Nr. ref.-no.	WS-Nr. ref.-no.	WS-Nr. ref.-no.	WS-Nr. ref.-no.			
1	2	Gehäusehälfte SVS1F -Schweißteil Housing Half SVS1F -weld part	1.4404 matt/satin fin.	09-94-007/44 H105317	09-94-008/44 H105318	09-94-009/44 H105319	09-94-010/44 H105320	09-94-010/44 H105320		
2	1	Klappe Disc	1.4404	08-55-680/43 H126403	08-55-730/43 H16132	08-55-780/43 H16141	08-55-830/43 H16148	08-55-830/43 H16148		
3	2	Flansch FG1 Flange FG1	1.4404 matt/satin fin.	09-51-677/42 H18839	09-51-727/42 H18858	09-51-777/42 H18861	09-51-827/42 H18866	09-51-827/42 H18866		
4	2	Dichtung FGN1 Seal FGN1	EPDM FDA-konform	58-32-677/93 H77351	58-32-727/93 H77357	58-32-777/93 H77359	58-32-827/93 H77360	58-32-827/93 H77360		
	2	Dichtung FGN1 Seal FGN1	FPM FDA-konform	58-32-677/73 H77350	58-32-727/73 H77356	58-32-777/73 H107921	58-32-827/73 H107922	58-32-827/73 H107922		
5	2	Dichtung FGN1 Seal FGN1	HNBR FDA-konform	58-32-677/33 H172136	58-32-727/33 H172137	58-32-777/33 H172138	58-32-827/33 H172139	58-32-827/33 H172139		
	2	Dichtung FGN1 Seal FGN1	VMQ FDA-konform	58-32-677/13 H77349	58-32-727/13 H77355	58-32-777/13 H77358	58-32-827/13	58-32-827/13		
6	2	Lagerbuchse Bearing	PA12 30%GF	08-01-160/93 H13836		08-01-161/93 H13837				
	1	Dichtung SVS1F Seal SVS1F	EPDM FDA-konform	58-33-685/93 H77605	58-33-735/93 H77622	58-33-785/93 H77641	58-33-835/93 H77668	58-33-835/93 H77668		
7	1	Dichtung SVS1F Seal SVS1F	FPM FDA-konform	58-33-685/73 H107944	58-33-735/73 H107945	58-33-785/73 H107946	58-33-835/73 H107947	58-33-835/73 H107947		
	1	Dichtung SVS1F Seal SVS1F	HNBR FDA-konform	58-33-685/33 H177200	58-33-735/33 H177201	58-33-785/33 H318439	58-33-835/33 H316821	58-33-835/33 H316821		
8	1	Dichtung SVS1F Seal SVS1F	VMQ FDA-konform	58-33-685/13 H207268	58-33-735/13 H15010	58-33-785/13 H149089	58-33-835/13 H207269	58-33-835/13 H207269		
	1	Skt. Mutter Hex. Nut	1.4301	65-50-080/15 8xM10	65-50-080/15 8xM10	65-50101/15 8xM12	65-50101/15 12xM12	65-50101/15 12xM12		
9	4	Skt. Schraube Hex. Screw	1.4301	65-01-147/13 8xM10x95	65-01-147/13 8xM10x95	65-01-207/13 8xM12x110	65-01-207/13 12xM12x110	65-01-207/13 12xM12x110		
	4	Zyl. Schraube Cyl. Screw	1.4301	65-05-122/13 2xM8x25	65-05-122/13 2xM8x25	65-05-122/13 4xM8x25	65-05-122/13 4xM8x25	65-05-122/13 4xM8x25		
10	4	Skt. Schraube Hex. Screw	1.4301	65-01-081/15 M8x16	65-01-081/15 M8x16	65-01-081/15 M8x16	65-01-081/15 M8x16	65-01-081/15 M8x16		
	4	Skt. Schraube Hex. Screw	1.4301	65-01-081/15 M8x16	65-01-081/15 M8x16	65-01-081/15 M8x16	65-01-081/15 M8x16	65-01-081/15 M8x16		



Ersatzteilliste: spare parts list

Scheibenventil SVS1F -FZ-CU
Butterfly valve SVS1F -A-CU
DN125-250 1+2S

Datum:	07.02.14
Name:	Trytko
Geprüft:	
Datum:	
Name:	
Geprüft:	

Blatt 3 von 4	
RN01.038.020	



pos. item	Menge quantity	Beschreibung description	Material	DN125	150	200	250	WS-Nr. ref.-no.	WS-Nr. ref.-no.	WS-Nr. ref.-no.
				WS-Nr. ref.-no.	WS-Nr. ref.-no.	WS-Nr. ref.-no.	WS-Nr. ref.-no.			
11	1	Kupplung Coupling	1.4057	08-52-099/17 H105096				08-52-199/17 H105099		
12	1	Laterne Yoke	1.4301	15-40-066/17 H33761						
13	2	Skt. Schraube Hex. Screw DIN EN 24017-A2-70	1.4301	65-01-130/15 M10x16 H78806						
14	1	Drehantrieb Actuator	1.4301	15-31-057/17 H105502				15-31-923/17 H32589		
15	1	Initiatorhalter SV-200+250 komplett Proximity switch holder SV-200+250 complete	1.4301					15-33-923/17 H153749		
15.1	1	Halter Holder	1.4301					15-33-923/15 H153747		
15.2	2	Skt. Schraube Hex. Screw DIN EN 24017-A2-70	1.4301					65-01-078/15 M8x10 H158966		
15.3	2	Scheibe Washer DIN 125 A8,4	1.4301					66-01-022/15 H79594		
16	1	Drehantrieb für Rückmeldeinheit Actuator for control unit	1.4301	15-37-106/17 H128942				15-37-103/17 H134034		
17	1	CU4-T-max-Adapter CU4-T-max-Adapter	PA6.6 GF30 schwarz					08-48-611/93 H321987		
18	1	Control-Unit CU Control-Unit CU	PA6.6 GF30 schwarz	siehe Betriebsanleitung CU see manual CU						
1	1	SVS1F ohne Drehantrieb ohne FG1 Flansche SVS1F without actuator and FG1 flange	EPDM-1.4404 matt-gl/satin fin	25-21-694/81 H106671	25-21-744/81 H106685	25-21-794/81 H106689	25-21-844/81 H106693			
1	1	SVS1F ohne Drehantrieb ohne FG1 Flansche SVS1F without actuator and FG1 flange	FPM-1.4404 matt-gl/satin fin	25-21-694/71 H106670	25-21-744/71	25-21-794/71 H106688	25-21-844/71 H204676			
1	1	SVS1F ohne Drehantrieb ohne FG1 Flansche SVS1F without actuator and FG1 flange	HNBR-1.4404 matt-gl/satin fin	25-21-694/96	25-21-744/96	25-21-794/96	25-21-844/96			
1	1	SVS1F ohne Drehantrieb ohne FG1 Flansche SVS1F without actuator and FG1 flange	VMQ-1.4404 matt-gl/satin fin	25-21-694/75	25-21-744/75	25-21-794/75	25-21-844/75			

Weitergabe sowie Vervielfältigung dieser Unterlage, Verwertung und Mitteilung ihres Inhalts nicht gestattet, soweit nicht schriftlich zugestanden. Verstos verpflichtet zum Schadensersatz und kann strafrechtliche Folgen haben (Paragraph 18 UWG, Paragraph 106 UrhG). Eigentum und alle Rechte, auch für Patenterteilung und Gebrauchsmustereintragung, vorbehalten. SPX FLOW, Germany

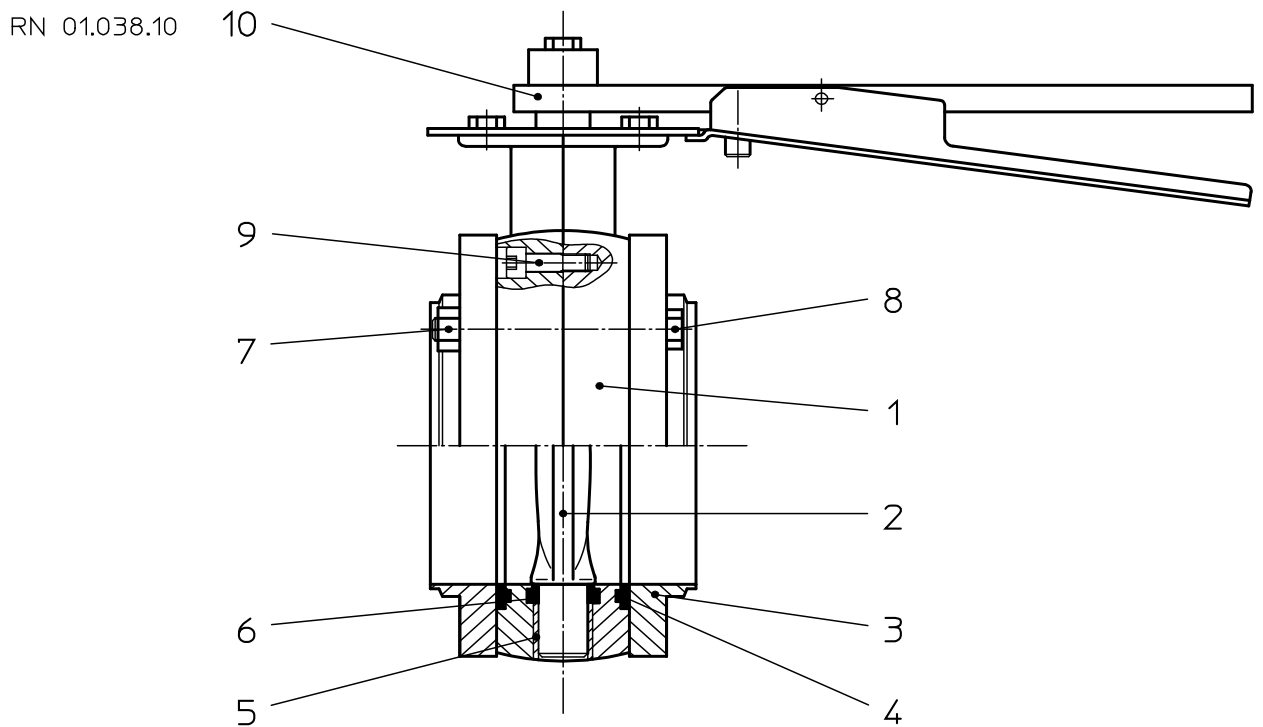
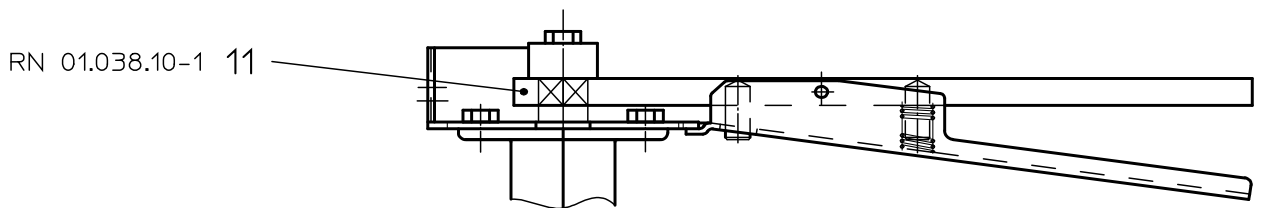

Datum:	03.02.14	24.11.16								
Name:	Trytko	C.Keil								
Geprüft:										

Ersatzteilliste: spare parts list

Scheibenventil SVS1F -Handbetätigung und Handbetätigung für Ventilstellungsmeldung
Butterfly valve SVS1F -handle and handle with position indicator
DN125-250 1+2S



SPX FLOW
Germany

Blatt 1 von 3

RN 01.038.021

Weitergabe sowie Vervielfältigung dieser Unterlage, Verwertung und Mitteilung ihres Inhalts nicht gestattet, soweit nicht schriftlich zugestanden. Verstößt verpflichtet zum Schadensersatz und kann strafrechtliche Folgen haben (Paragraf 18 UWG, Paragraf 106 UrhG). Eigentum und alle Rechte, auch für Patenterteilung und Gebrauchsmustererteilung, vorbehalten. SPX FLOW, Germany

Ersatzteilliste: spare parts list

**Scheibenventil SVS1F -Handbetätigung und Handbetätigung für
Ventilstellungsmeldung
Butterfly valve SVS1F -handle and handle with position indicator
DN125-250 1+2S**

Datum:	03.02.14	24.11.16
Name:	Trytko	C. Keil
Geprüft:		
Datum:		
Name:		
Geprüft:		
Blatt 2 von 3		
RN01.038.021		

item	Menge quantity	Beschreibung description	Material	DN125	150	200	250	WS-Nr. ref.-no.	WS-Nr. ref.-no.	WS-Nr. ref.-no.
1	2	Gehäusehälfte SVS1F -Schweißteil Housing Half SVS1F -weld part	1.4404 matt/satin fin.	09-94-007/44 H105317	09-94-008/44 H105318	09-94-009/44 H105319	09-94-010/44 H105320	08-55-680/43 H126403	08-55-730/43 H16132	08-55-830/43 H16148
2	1	Klappe Disc	1.4404	09-51-677/42 H18839	09-51-727/42 H18858	09-51-777/42 H18861	09-51-827/42 H18866	09-51-677/42 H18839	09-51-727/42 H18858	09-51-827/42 H18866
3	2	Flansch FG1 Flange FG1	1.4404 matt/satin fin.	58-32-677/93 H77351	58-32-727/93 H77357	58-32-777/93 H77359	58-32-827/93 H77360	58-32-677/93 H77351	58-32-727/93 H77357	58-32-827/93 H77360
4	2	Dichtung FGN1 Seal FGN1	EPDM	58-32-677/73 H77350	58-32-727/73 H77356	58-32-777/73 H107921	58-32-827/73 H107922	58-32-677/73 H77350	58-32-727/73 H77356	58-32-827/73 H107922
	2	Dichtung FGN1 Seal FGN1	HNBR	58-32-677/33 H172136	58-32-727/33 H172137	58-32-777/33 H172138	58-32-827/33 H172139	58-32-677/33 H172136	58-32-727/33 H172137	58-32-827/33 H172139
	2	Dichtung FGN1 Seal FGN1	VMQ FDA-konform	58-32-677/13 H77349	58-32-727/13 H77355	58-32-777/13 H77358	58-32-827/13 H77358	58-32-677/13 H77349	58-32-727/13 H77355	58-32-827/13 H77358
5	2	Lagerbuchse Bearing	PA12 30%GF	08-01-160/93 H13836		08-01-161/93 H13837				
	1	Dichtung SVS1F Seal SVS1F	EPDM FDA-konform	58-33-685/93 H77605	58-33-735/93 H77622	58-33-785/93 H77641	58-33-835/93 H77668	58-33-685/93 H77605	58-33-735/93 H77622	58-33-835/93 H77668
6	1	Dichtung SVS1F Seal SVS1F	FPM FDA-konform	58-33-685/73 H107944	58-33-735/73 H107945	58-33-785/73 H107946	58-33-835/73 H107947	58-33-685/73 H107944	58-33-735/73 H107945	58-33-835/73 H107947
	1	Dichtung SVS1F Seal SVS1F	HNBR FDA-konform	58-33-685/33 H177200	58-33-735/33 H177201	58-33-785/33 H318439	58-33-835/33 H316821	58-33-685/33 H177200	58-33-735/33 H177201	58-33-835/33 H316821
	1	Dichtung SVS1F Seal SVS1F	VMQ FDA-konform	58-33-685/13 H207268	58-33-735/13 H15010	58-33-785/13 H149089	58-33-835/13 H207269	58-33-685/13 H207268	58-33-735/13 H15010	58-33-835/13 H207269
7		Skt. Mutter Hex. Nut	1.4301	65-50-080/15 8xM10	DIN EN 24032-A2 H79287	65-50101/15 8xM12	65-50101/15 12xM12	65-50-080/15 8xM10	65-50101/15 H79298	65-50101/15 12xM12
8		Skt. Schraube Hex. Screw	1.4301	65-01-147/13 8xM10x95	H78826	65-01-207/13 8xM12x110	65-01-207/13 12xM12x110	65-01-147/13 8xM10x95	65-01-207/13 H79014	65-01-207/13 12xM12x110
9		Zyl. Schraube Cyl. Screw	1.4301	65-05-122/13 2xM8x25	H79014	65-05-122/13 4xM8x25	65-05-122/13 H79014	65-05-122/13 2xM8x25	65-05-122/13 H79014	65-05-122/13 4xM8x25
10	1	Handbetätigung Handle	1.4301	08-41-260/17 H15209	08-41-260/17 H15210	08-41-261/17 H15210		08-41-260/17 H15209	08-41-260/17 H15210	08-41-261/17 H15210



Weitergabe sowie Vervielfältigung dieser Unterlage, Verwertung und Mitteilung ihres Inhalts nicht gestattet, soweit nicht schriftlich zugestanden. Verstößt verpflichtet zum Schadensersatz und kann strafrechtliche Folgen haben (Paragraf 18 UWG, Paragraf 106 UrhG). Eigentum und alle Rechte, auch für Patentteilung und Gebrauchsmusterantragung, vorbehalten. SPX FLOW, Germany

Ersatzteilliste: spare parts list

Scheibenventil SVS1F -Handbetätigung und Handbetätigung für Ventilstellungsmeldung
Butterfly valve SVS1F -handle and handle with position indicator
DN125-250 1+2S

Datum:	03.02.14	24.11.16
Name:	Trytko	C.Keil
Geprüft:		
Datum:		
Name:		
Geprüft:		



Blatt 3 von 3
RN01.038.021

pos. item	Menge quantity	Beschreibung description	Material	DN125	150	200	250	WS-Nr. ref.-no.	WS-Nr. ref.-no.	WS-Nr. ref.-no.
11	1	Handbetätigung für VSM Handle with position indicator	1.4301	08-41-270/17 H105073	08-41-271/17 H105074					
	1	SVS1F ohne Handbetätigung ohne FG1 Flansche without handle and FG1 flange	EPDM-1.4404 matt-gl/satin fin	25-21-694/81 H106671	25-21-744/81 H106685	25-21-794/81 H106689	25-21-844/81 H106693			
	1	SVS1F ohne Handbetätigung ohne FG1 Flansche without handle and FG1 flange	FPM-1.4404 matt-gl/satin fin	25-21-694/71 H106670	25-21-744/71	25-21-794/71 H106688	25-21-844/71 H204676			
	1	SVS1F ohne Handbetätigung ohne FG1 Flansche without handle and FG1 flange	HNBR-1.4404 matt-gl/satin fin	25-21-694/96	25-21-744/96	25-21-794/96	25-21-844/96			
	1	SVS1F ohne Handbetätigung ohne FG1 Flansche without handle and FG1 flange	VMQ-1.4404 matt-gl/satin fin	25-21-694/75	25-21-744/75	25-21-794/75	25-21-844/75			
Pos. 4, 5, 6 nur im kompletten Dichtungssatz erhältlich Item 4, 5, 6 available as complete seal kits only										
	1	Dichtungssatz Seal kit	FPM	58-34-562/00 H314406	58-34-563/00 H316433	58-34-579/00 H316434	58-34-580/00 H316435			
	1	Dichtungssatz Seal kit	EPDM	58-34-562/01 H206676	58-34-563/01 H206677	58-34-579/01 H206683	58-34-580/01 H206684			
	1	Dichtungssatz Seal kit	HNBR	58-34-562/02 H316455	58-34-563/02 H312575	58-34-579/02 H324333	58-34-580/02 H325391			
	1	Dichtungssatz Seal kit	VMQ	58-34-562/06 H317198	58-34-563/06 H316456	58-34-579/06 H325395	58-34-580/06 H317162			

Weitergabe sowie Vervielfältigung dieser Unterlage, Verwertung und Mitteilung ihres Inhalts nicht gestattet, soweit nicht schriftlich zugestanden. Verstößt verpflichtet zum Schadensersatz und kann strafrechtliche Folgen haben (Paragraph 18 UWG, Paragraph 106 UrhG). Eigentum und alle Rechte, auch für Patenterteilung und Gebrauchsmustereintragung, vorbehalten. SPX FLOW, Germany

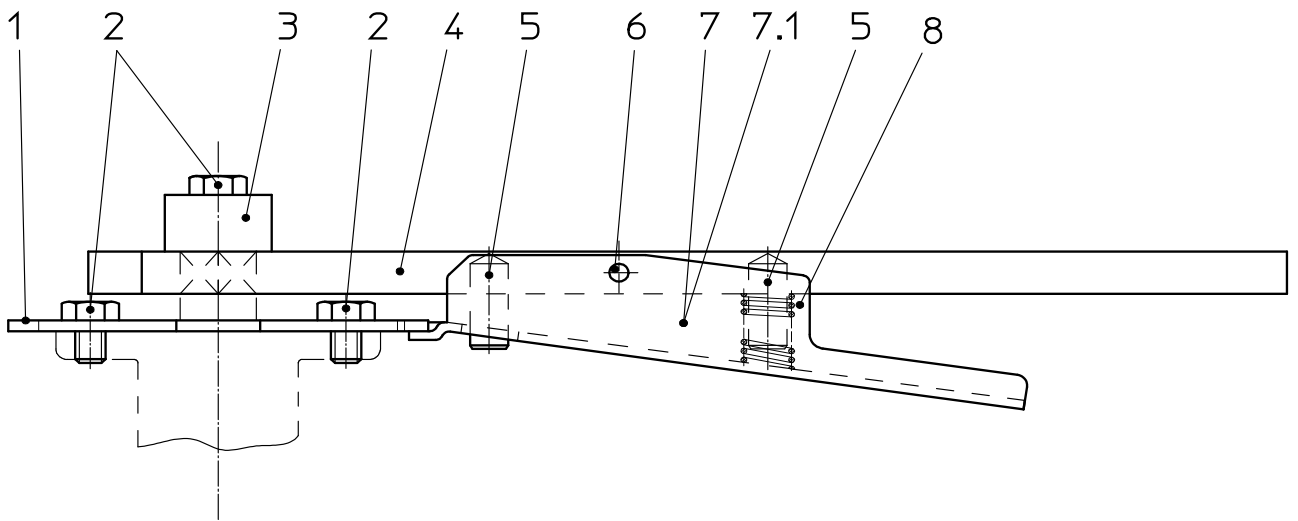

Datum:	10.02.14									
Name:	Trytko									
Geprüft:										

Ersatzteilliste: spare parts list

Handbetätigung mit Endlagenverriegelung und Handbetät. abschließbar für SVS1F
Handle with lockingdevice and handle lockable for batterfly valves SVS1F
DN125-250



SPX FLOW
Germany

Blatt 1 von 2

RN01.038.10

Weitergabe sowie Vervielfältigung dieser Unterlage, Verwertung und Mitteilung ihres Inhalts nicht gestattet, soweit nicht schriftlich zugestanden. Verstößt verpflichtet zum Schadensersatz und kann strafrechtliche Folgen haben (Paragraph 18 UWG, Paragraph 106 UrhG). Eigentum und alle Rechte, auch für Patenterteilung und Gebrauchsmustereintragung, vorbehalten. SPX FLOW, Germany

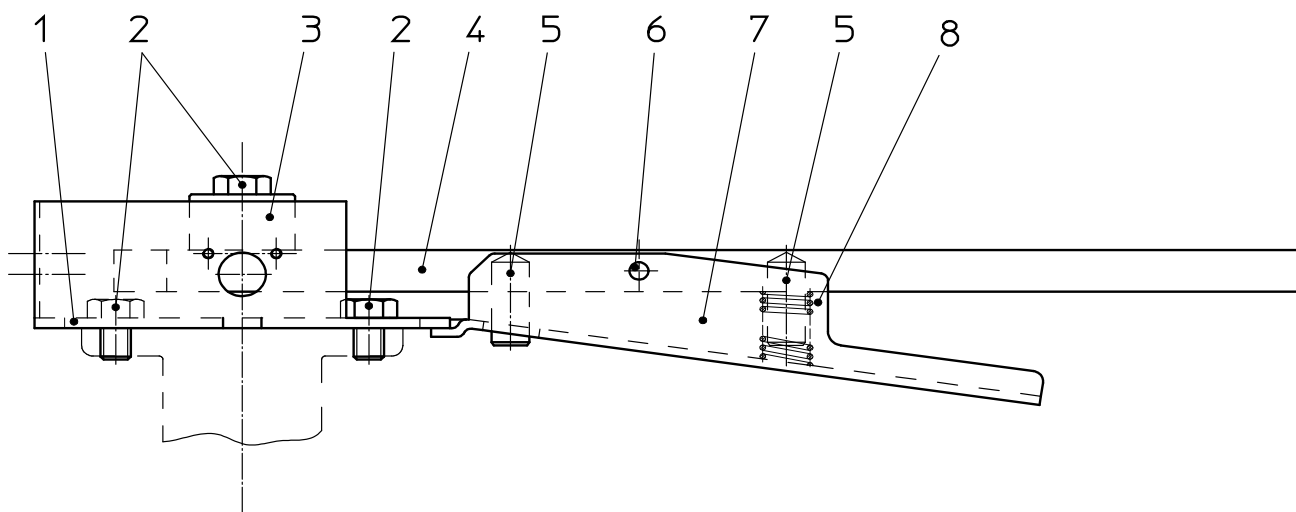

Datum:	10.02.14									
Name:	Trytko									
Geprüft:										

Ersatzteilliste: spare parts list

Handbetätigung mit Endlagenverriegelung für Ventilstellungsmeldung SVS1F
Handle with lockingdevice for valve position indicator for butterfly valves SVS1F
DN125-250



SPX FLOW
Germany

Blatt 1 von 2

RN01.038.10-1

Weitergabe sowie Vervielfältigung dieser Unterlage, Verwertung und Mitteilung ihres Inhalts nicht gestattet, soweit nicht schriftlich zugestanden. Verstößt verpflichtet zum Schadensersatz und kann strafrechtliche Folgen haben (Paragraf 18 UWG, Paragraf 106 UrhG). Eigentum und alle Rechte, auch für Patenterteilung und Gebrauchsmustereintragung, vorbehalten. SPX FLOW, Germany

Ersatzteilliste: spare parts list

**Handbetätigung mit Endlagenverriegelung für Ventilstellungsmeldung SVS1F
Handle with locking device for valve position indicator for butterfly valves SVS1F
DN125-250**

		Datum: 10.02.14								Blatt 2 von 2	
		Name: Trytko								RN01.038.10-1	
		Geprüft:									
		Datum:									
		Name:									
		Geprüft:									
		DN200	DN150	DN125	Material		DN250	WS-Nr. ref.-no.	WS-Nr. ref.-no.	WS-Nr. ref.-no.	
1	Handbetätigung mit VSM komplett Handle with position indicator complete	1.4301	08-41-270/17 H105073	08-41-270/17 H105074	1.4301	08-41-271/17 H105074					
1	Rasterscheibe Scale disc	1.4301	08-20-012/17 H105058	08-20-012/17 H105058	1.4301	08-20-012/17 H105058					
2	Skt. Schraube Hex. Screw	1.4301	65-01-080/15 M8x12 H78770		1.4301						
3	Druckstück Spacer	1.4301	08-48-003/17 H15327	08-48-021/17 H15340	1.4301	08-48-021/17 H15340					
4	Handhebel komplett Handle complete	1.4301	08-41-280/17 H105075	08-41-281/17 H105076	1.4301	08-41-281/17 H105076					
5	Steckerbstift Grooved pin	1.4305	67-15-034/13 10x24 H79915		1.4305						
6	Schwerspannstift Heavy duty dowel pin	INOX-1.4310	67-17-021/13 S5x18 H79932		INOX-1.4310						
7	Unterzange Lower tongs	1.4301	08-41-067/17 H15062		1.4301						
8	Druckfeder Pressure spring	1.4310	60-06-006/13 H78352		1.4310						



Weitergabe sowie Vervielfältigung dieser Unterlage, Verwertung und Mitteilung ihres Inhalts nicht gestattet, soweit nicht schriftlich zugestanden. Verstößt verpflichtend zum Schadensersatz und kann strafrechtliche Folgen haben (Paragraf 18 UW/G, Paragraf 106 UrtG). Eigentum und alle Rechte, auch für Patenterteilung und Gebrauchsmustererteilung, vorbehalten. SPX FLOW, Germany

Ersatzteilliste: spare parts list

Drehantrieb K080, K125, K180 F/L
Actuator K080, K125, K180 spring/air

Datum:	22.11.12	12.03.14
Name:	Trytko	Trytko
Geprüft:	Goebel	

Datum:	1	von	2
Name:			
Geprüft:			



Blatt 1 von 2
RN 01.073

DRAT K080

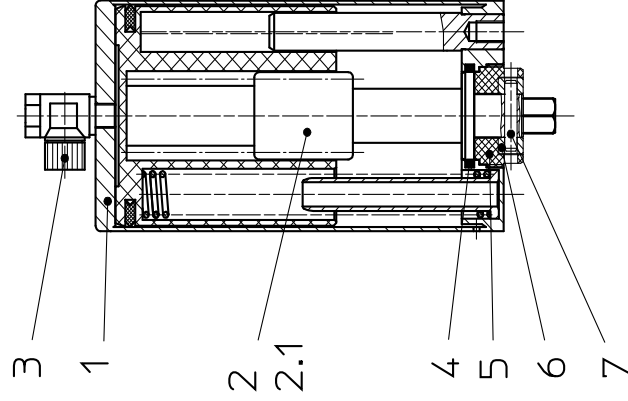

DRAT K125

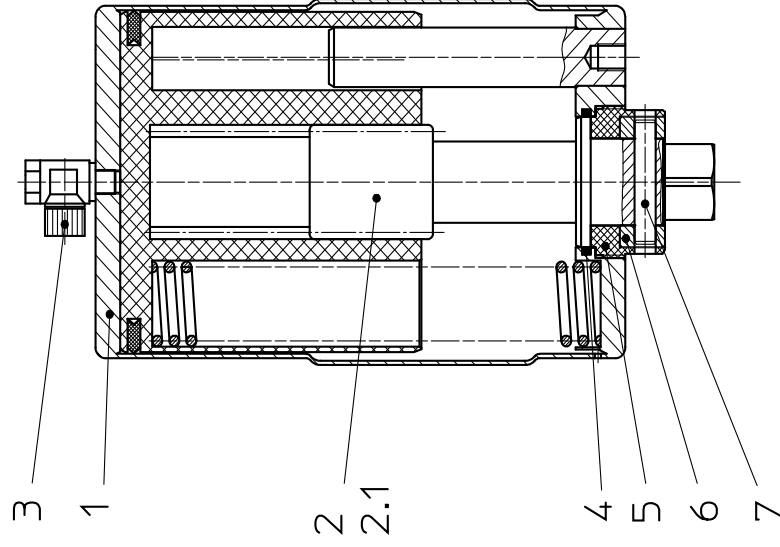

DRAT K180

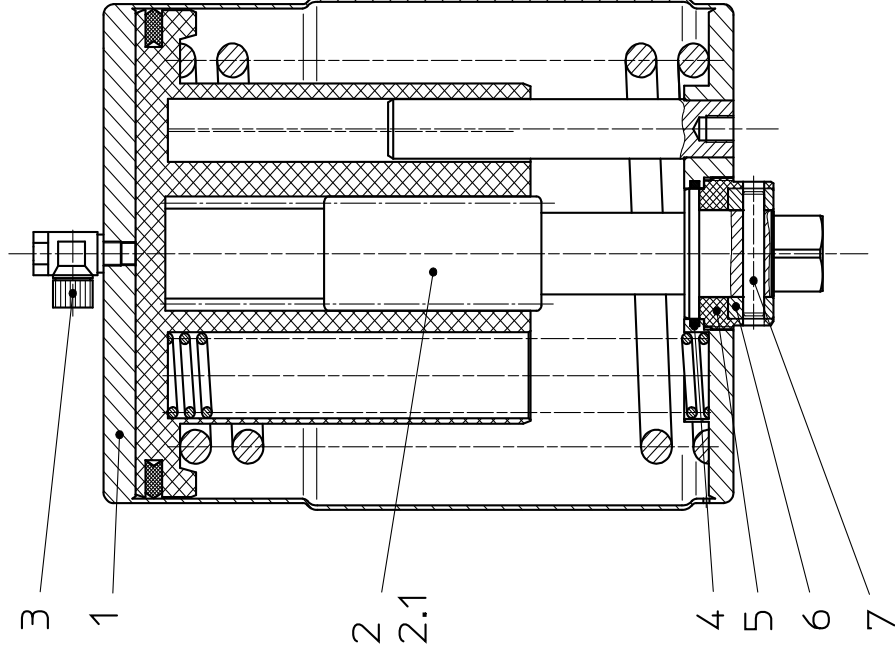

Ersatzteilliste: spare parts list

**Drehantrieb K080, K125, K180 F/L
Actuator K080, K125, K180 spring/air**

pos. item	Menge quantity	Beschreibung description	Material	K080			K125			K180			Date:		12.03.14		Blatt 2 von 2		RN 01.073
				WS-Nr. ref.-no.	WS-Nr. ref.-no.	WS-Nr. ref.-no.	WS-Nr. ref.-no.	WS-Nr. ref.-no.	WS-Nr. ref.-no.	WS-Nr. ref.-no.	WS-Nr. ref.-no.	Name: Trytko	Trytko	Name: Goebel	Goebel	WS-Nr. ref.-no.	WS-Nr. ref.-no.		
1	1	Drehantrieb komplett Actuator complete	1.4301 matt-glänzend	15-31-055/17 H105500	15-31-057/17 H105502	15-31-923/17 H32589													
1	1	Drehantrieb komplett Actuator complete	1.4301 poliert	15-31-055/13 H135919	15-31-057/13 H131940	15-31-923/13 H32588													
1	1	Drehantrieb Schweißteil Actuator welded	1.4301	15-31-054/17 H105499	15-31-056/17 H105501	15-31-922/17 H32587													
2	1	Spindel komplett mit Lager Shaft complete with bearing	1.4301	15-24-021/13 H31494	15-24-031/13 H31502	15-24-033/13 H31504													
2.1	1	Spindel Shaft	1.4301	15-24-020/13 H31493	15-24-030/13 H31501	15-24-032/13 H31503													
3	1	Winkelverschraubung G1/8" schwenkbar Elbow union G1/8" slewable	Polyamid/ Glasf	08-63-221/93 H16371															
4	1	O-Ring	NBR	58-06-130/83 32,2x3 H76965															
	1	O-Ring	FPM			58-06-222/73 49,5x3 H77000													
5	1	Lager für Drehantrieb Bearing for actuator	POM	15-28-002/34 H31673															
	1	Lager für Drehantrieb Bearing for actuator	PA12		15-28-009/63 H31684														
6	1	Stelling Adjust ring	1.4301	67-08-007/13 H79757	67-08-008/13 H79758														
7	1	Zyl. Kerbstift Cyl. pin	1.4305	67-15-035/13 5x26 H79916	67-15-036/13 8x45 H79917														



Weitergabe sowie Vervielfältigung dieser Unterlage, Verwertung und Mitteilung ihres Inhalts nicht gestattet, soweit nicht schriftlich zugestanden. Verstoß verpflichtet zum Schadensersatz und kann strafrechtliche Folgen haben (Paragraf 18 UWG, Paragraf 106 UrtG). Eigentum und alle Rechte, auch für Patenterteilung und Gebrauchsmustererteilung, vorbehalten. SPX FLOW, Germany

Ersatzteilliste: spare parts list

Drehantrieb K080, K125, K180 F/L für Rückmeldeeinheit
Actuator K080, K125, K180 spring/air for control unit

Datum: 28.03.13 08.05.14
 Name: Trytko Trytko
 Geprüft:

Datum: 1 von 2
 Name: von
 Geprüft: RN 01.076

APV
 SPX Flow Technology Rosista GmbH
 D-59425 Umma Germany

DRAT K080-RM

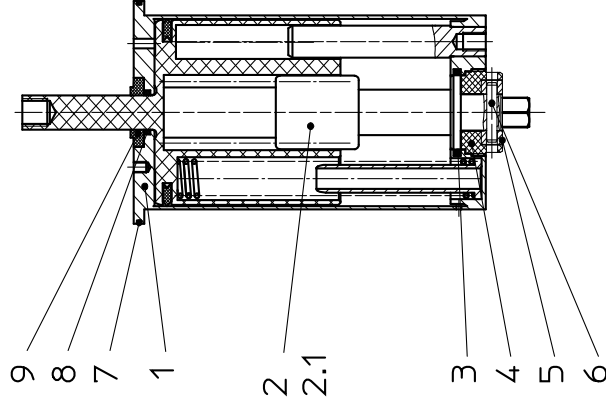

DRAT K125-RM

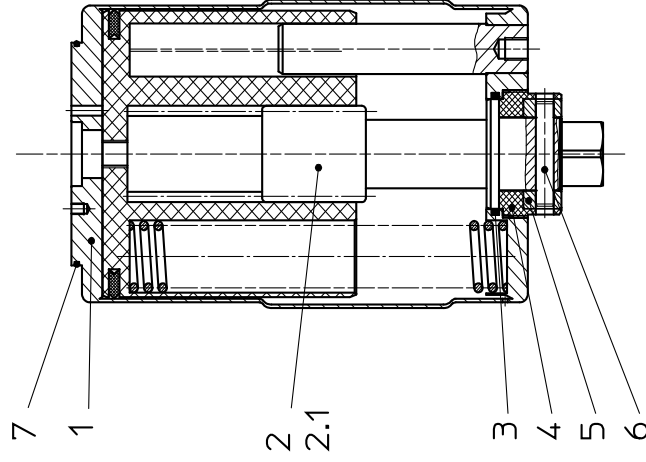

DRAT K180-RM

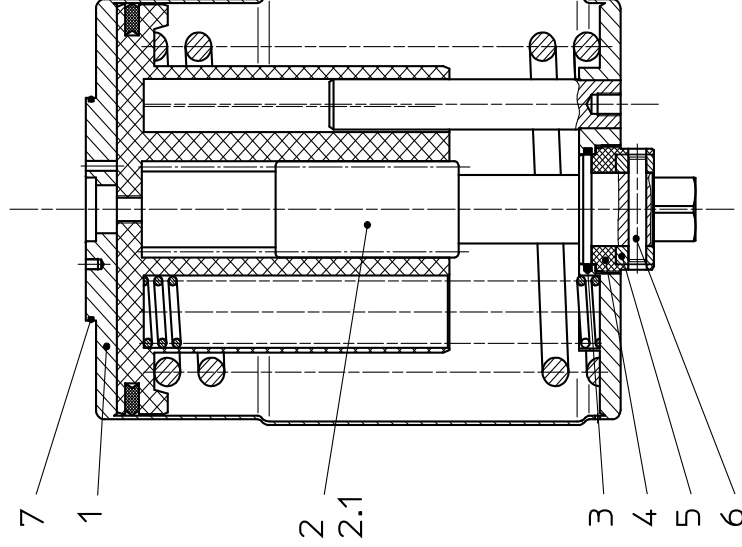

APV DELTA SVS1F DN 125-250

BUTTERFLY VALVE

SPXFLOW

SPX FLOW

Design Center

Gottlieb-Daimler-Straße 13
D-59439 Holzwickede, Germany
P: (+49) (0) 2301-9186-0
F: (+49) (0) 2301-9186-300

SPX FLOW

Production

Stefana Rolbieskiego 2
PL- Bydgoszcz 85-862, Poland
P: (+48) 52 566 76 00
F: (+48) 52 525 99 09

SPX FLOW reserves the right to incorporate the latest design and material changes without notice or obligation.

Design features, materials of construction and dimensional data, as described in this manual, are provided for your information only and should not be relied upon unless confirmed in writing. Please contact your local sales representative for product availability in your region. For more information visit www.spxflow.com.

ISSUED 08/2017 - Translation of Original Manual
COPYRIGHT ©2017 SPX FLOW, Inc.

Scan for SV1/SVS1F Valve
Maintenance Video

