

TopWing

ULTRA-HYGIENIC ROTARY LOBE PUMPS

A.0500.301 – IM-TW/16.00 EN (06/2019)

ORIGINAL INSTRUCTIONS
READ AND UNDERSTAND THIS MANUAL PRIOR TO OPERATING
OR SERVICING THIS PRODUCT.



02 - 10

EC-Declaration of conformity

(as per EC's Machinery Directive 2006/42/EC, Annex IIA)

Manufacturer

SPX Flow Technology Poland Sp. z o.o.,
ul. Rolbieskiego 2
85-862 Bydgoszcz, Poland

We hereby guarantee that **TopWing rotary lobe pumps**

type: TW1/0041
TW1/0082
TW2/0171
TW2/0343
TW3/0537
TW3/1100
TW4/1629
TW4/3257

are in conformity with EC's Machinery Directive 2006/42/EC, Annex I.

Manufacturer Declaration

(as per EC's Machinery Directive 2006/42/EC, Annex IIB)

The product must not be put into service until the machinery into which it is to be incorporated has been declared in conformity with the provisions of the Directive.

Bydgoszcz, Poland, 4 June 2019



Jacek Goska
Managing Director

Table of Contents

1.0	Introduction	7
1.1	General.....	7
1.1.1	Intended Use.....	7
1.2	Receipt, storage and handling.....	7
1.2.1	Receipt, storage	7
1.2.2	Handling	8
1.3	Safety instructions.....	9
1.3.1	General.....	9
1.3.2	Pump units.....	11
1.3.2.1	Pump unit handling.....	11
1.3.2.2	Installation.....	11
1.3.2.3	Before commissioning the pump unit.....	11
1.3.2.4	Disassembly/assembly of the coupling guard.....	12
1.3.2.5	Name plate – CE Declaration of Conformity.....	12
1.4	Pump designation - Full pump range	13
1.5	Pump designation - EHEDG approved pumps.....	15
1.6	Pump designation - 3-A approved pumps.....	17
1.7	Pump model and serial number	19
1.8	Pump standard parts.....	19
2.0	Function, construction, installation	20
2.1	Operating principle.....	20
2.2	Operating parameters.....	21
2.2.1	Operating parameters Bi-wing rotors.....	21
2.2.2	Operating parameters Multi-lobe rotors	21
2.3	System design and installation	22
2.3.1	Installations with CIP-systems, Cleaning In Place.....	23
2.3.2	Installations with SIP-systems, Sterilising In Place	24
2.4	Start	24
2.5	Shutdown.....	25
2.6	Routine maintenance	25
2.7	Typical CIP (Cleaning In Place) cycle.....	25
2.8	Typical SIP (Sterilizing In Place) cycle	25
2.9	Trouble shooting chart	26
3.0	Technical data.....	27
3.1	Rotor clearances - Bi-wing rotors.....	27
3.2	Rotor clearances - Multi-lobe rotors	28
3.3	Oil volume in gearboxes	29
3.4	Material specification	30
3.4.1	Machined parts – Pump	30
3.5	Dimensional drawings and weights	31
3.5.1	Standard.....	31
3.5.2	Vertical mounting.....	32
3.5.3	Connections.....	33
3.5.3.1	Standard pump.....	33
3.5.3.2	Enlarged inlet	33
3.5.4	Thread and clamp connections.....	34
3.5.5	Industrial DIN and ANSI flanges - Non-hygienic.....	36
3.5.6	Hygienic DIN 11864-2 Form A flanges.....	36

3.6	Weights	37
3.6.1	Weights standard pump	37
3.7	Sound level.....	37
3.7.1	Pumps with Bi-wing rotors.....	37
3.7.2	Pumps with Multi-lobe rotors	38
3.8	Solid particles	38
4.0	Disassembly and assembly instructions.....	39
4.1	Tools to be used.....	39
4.2	General instructions	40
4.3	O-rings and lip seals.....	40
4.4	Shutdown	40
4.5	Tightening torque [Nm] for nuts and screws	41
4.6	Disassembly	42
4.6.1	Pump cover and rotor removal	42
4.6.2	Disassembly of seals.....	43
4.6.2.1	Single mechanical seal	43
4.6.2.2	Single mechanical seal with flushing.....	44
4.6.2.3	Double mechanical seal.....	44
4.6.2.4	Single O-ring seal	45
4.6.2.5	Double O-ring seal	45
4.6.3	Disassembly of drive assembly	46
4.6.4	Disassembly of shaft arrangement.....	47
4.6.5	Disassembly of rotor case.....	48
4.7	Assembly.....	48
4.7.1	Pre-assembly of the rotor case.....	48
4.7.1.1	Foot assembly.....	48
4.7.1.2	Assembly of lip seals.....	48
4.7.2	Pre-assembly of shaft/bearing arrangement.....	48
4.7.3	Assembly of shafts in the rotor case and setting of the tapered roller bearings	50
4.7.4	Axial adjustment of the rotors.....	51
4.7.5	Assembly of gears.....	52
4.7.6	Synchronization of the rotors.....	53
4.7.6.1	Manual synchronization.....	53
4.7.6.2	Synchronization with special tools.....	54
4.7.7	Assembly of end cover.....	54
4.7.8	Assembly of seals	55
4.7.8.1	Single mechanical seal	55
4.7.8.2	Single mechanical seal with flushing.....	56
4.7.8.3	Double mechanical seal.....	57
4.7.8.4	Single O-ring seal.....	58
4.7.8.5	Double O-ring seal	58
4.7.9	Assembly of rotors and pump cover	59
4.7.9.1	Assembly of rotors.....	59
4.7.9.2	Assembly of pump cover.....	59

5.0	Special tools	60
5.1	General.....	60
5.2	Assembly tool for lip seals	60
5.3	Assembly sleeve for shaft cartridge.....	61
5.4	Assembly tool for lip seal	62
5.5	Assembly tool for V-seal.....	62
5.6	Tool kit for synchronization of the pump shafts	63
5.7	Tool for disassembly O-ring seal TW1	63
6.0	Sectional drawings and parts list.....	64
6.1	Overview	64
6.2	Recommended spare parts	65
6.3	Hydraulic part	67
6.3.1	Hydraulic part, complete.....	67
6.3.2	TopKits options	68
6.3.2.1	O-ring kit for hydraulic part.....	68
6.3.2.2	O-ring kit for hydraulic part with safety relief valve	69
6.3.3	Rotor complete	70
6.3.4	Pump cover options.....	70
6.3.4.1	Flat pump cover.....	70
6.3.5	Feet options.....	71
6.4	Drive assembly.....	72
6.4.1	Drive assembly, complete.....	72
6.4.2	Service kit for drive assembly.....	73
7.0	Single mechanical seal with/without flushing.....	74
7.1	General information	74
7.2	Seal options	75
7.2.1	Single mechanical seal	75
7.2.2	Single mechanical seal with flushing	76
7.3	O-ring kits.....	77
7.3.1	Single mechanical seal	77
7.3.2	Single mechanical seal with flushing	78
8.0	Double mechanical seal	79
8.1	General information	79
8.2	Seal options	80
8.3	O-ring kits - Double mechanical seal.....	81
9.0	Single O-ring seal and double O-ring seal.....	82
9.1	General information	82
9.2	Machined parts – Seal assemblies and flush covers	83
9.3	Seal options	84
9.3.1	Single O-ring seal	84
9.3.2	Double O-ring seal	84
9.4	O-ring kits.....	85
9.4.1	O-ring kit for single O-ring seal	85
9.4.2	O-ring kit for double O-ring seal	86

10.0	Quench and Flush connections	87
10.1	Seal plans	88
10.1.1	Pump connections in horizontal position.....	88
10.1.2	Pump connections in vertical position.....	91
11.0	Valves and jackets	94
11.1	Heating and cooling jackets.....	94
11.2	Built-on safety relief valves.....	94
11.2.1	General description	95
11.2.2	Safety relief valve - Spring Loaded.....	96
11.2.2.1	Spring Loaded.....	96
11.2.2.2	Spring loaded completely opened.....	96
11.2.3	Safety relief valve - Spring loaded - air lifted.....	97
11.2.3.1	Spring loaded - air lifted.....	97
11.2.3.2	Spring loaded - air lifted with CIP/SIP valve function.....	98
11.2.4	Setting and operating – Spring loaded and spring loaded - air lifted	99
11.2.5	Safety relief valve - air loaded - air lifted.....	101
11.2.5.1	Air loaded.....	101
11.2.5.2	Air loaded-air lifted with CIP/SIP valve function	102
11.2.6	Setting and operating – Air loaded - air lifted safety relief valves	103
11.3	Disassembly/Assembly.....	104
11.3.1	Spring loaded valves.....	104
11.3.1.1	Disassembly	104
11.3.1.2	Assembly.....	104
11.3.2	Spring loaded - air lifted valves.....	105
11.3.2.1	Disassembly	105
11.3.2.2	Assembly.....	105
11.3.3	Air loaded - air lifted valves.....	106
11.3.3.1	Disassembly.....	106
11.3.3.2	Assembly.....	106
11.4	Dimensional drawings and weights	107
11.4.1	Heating/cooling jackets and Safety relief valves	107
11.5	Weights safety relief valve	109
11.6	Sectional drawings and parts list.....	110
11.6.1	Pump cover with safety relief valve spring loaded.....	110
11.6.2	Pump cover with safety relief valve spring loaded - air lifted.....	111
11.6.3	Pump cover with safety relief valve air loaded - air lifted.....	112

1.0 Introduction

1.1 General

The range of TopWing rotary lobe pumps are manufactured by SPX and are sold and marketed by a network of authorized distributors.

This instruction manual contains necessary information of the TopWing pumps and must be read carefully before installation, service and maintenance. The manual must be kept easily accessible by the operator.



Important!

If it is proposed to modify the system/duty or to use the pump for transporting liquids with other characteristics than for which the pump was originally selected always consult your supplier.

For additional information regarding the TopWing pumps, please contact your supplier.

1.1.1 Intended Use

The TopWing Rotary Lobe Pumps are exclusively intended for pumping liquids, especially in beverage and food installations as well as in comparable applications of the chemical, pharmaceutical and health care industries.

Its use is permissible only within the admissible pressure and temperature margins and under consideration of chemical and corrosive influences.

Any use exceeding the margins and specifications set forth, is considered to be not intended. Any damage resulting therefrom is not within the responsibility of the manufacturer. The user will bear the full risk.

Attention: *Improper use of the pumps leads to:*

- damage
 - leakage
 - destruction.
-
- Failures in the production process are possible

1.2 Receipt, storage and handling

1.2.1 Receipt, storage

Check the consignment for damage immediately on arrival. In case of damage, clearly mark upon the carrier's paperwork (with a brief description of the damage) that the goods have been received in a damaged condition. Notify your supplier.

Always state the pump model and serial number when asking for assistance. This information can be obtained from the name plate which is located on the end cover.

Should the name plate be unreadable or missing, the serial number is also stamped on the end cover and the rotor case.

If the pump is not installed immediately, it must be stored in a suitable environment.

1.2.2 Handling

Caution must be taken when lifting the pump. All parts with a weight of more than 20 kg must be lifted using lifting slings and suitable lifting devices.

Lifting eye fitted to pump must only be used to lift the pump, not the pump with drive and/or baseplate.

If the pump is baseplate mounted, the baseplate must be used for all lifting purposes. When using slings, they must be safely and securely attached (1.3 Safety instructions).

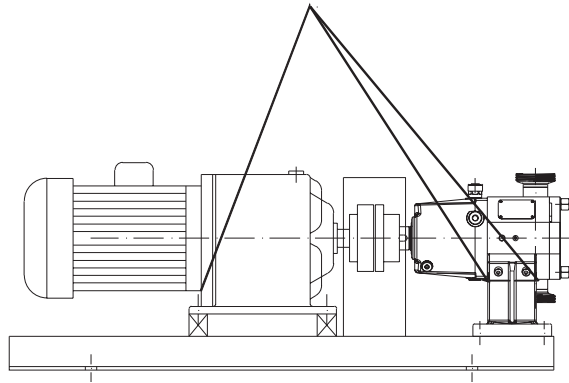
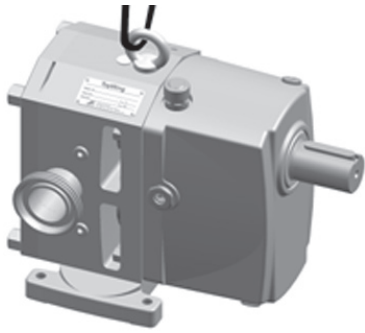

1.3 Safety instructions

1.3.1 General

This information must be read carefully before installation, operation or servicing and always readably be available to the pump operator.

Instructions which can affect personal safety if not followed, are marked with this symbol 

Instructions to be considered for safe operations or to protect the pump/pump unit are marked with this symbol 

When ATEX pump/pump unit is supplied, the separate ATEX manual must be considered 



- Incorrect installation, operation or maintenance of the equipment can cause serious personal injury and/or damage to the equipment and will invalidate the warranty.



- Never operate the pump if the pump cover or suction and discharge pipework are not in place. Likewise, never operate the pump if other protection such as coupling and touch guards are missing or incorrectly fitted.



- Never stick your fingers inside the rotor case, connections to the casing or in the end cover if there is any possibility that the pump shafts may rotate. This can lead to serious personal injury.



- Do not exceed the pump's maximum operating pressure, speed or temperature. Do not modify the operating parameters/system for which the pump was originally delivered without first consulting your supplier.



- Pump installation and operation must always comply with prevailing health and safety regulations.



- Some sort of safety equipment should be connected to the pump, system or the drive to prevent the pump from exceeding maximum allowable pressure. The safeguard system must be configured to handle reverse flow where applicable.

Do not operate the pump with a closed/blocked discharge unless a safety relief valve is incorporated. If an integrated safety relief valve is incorporated into the pump, do not allow extended periods of recirculation through the relief valve.



- The installation of the pump/pump unit must be sturdy and stable. Pump orientation must be considered with respect to drainage requirements. Once mounted, check the alignment between the pump and the drive assembly. Misalignment of the pump, drive and shaft coupling will result in unnecessary wear, increased operating temperatures and noisier operation.



- Fill the pump's and drive's end cover with the recommended lubricants and amounts. Change the lubricants at the recommended intervals.



- Before operating the pump, make sure that it and the pipe system are clean and free from debris and that all the valves in the suction and discharge pipelines are fully opened. Make sure that all pipework connected to the pump is fully supported and correctly aligned. Misalignment and/or excessive loads will cause severe damage to the pump.

- Make sure that the pump rotation is correct for the desired flow direction.



- Do not install the pump into a system where it may run dry (i.e. without a supply of pumped media) unless it is equipped with a flushed shaft seal arrangement, complete with a fully operational flushing system.



- Install pressure gauges/sensors in conjunction with the pump's suction and discharge connections to monitor the pump's pressure.



- Caution must be taken when lifting the pump, appropriate lifting devices should be used if possible. Lifting rings fitted to the pump are only to be used for lifting the pump, not for lifting the pump with drive and/or baseplate. For baseplate mounted pumps the baseplate is to be used for all lifting purposes. If slings are used for lifting, they must be safely and securely attached.



- Do not attempt maintenance work or disassembly of the pump or pump unit without making sure that the power switch to the drive unit (electric, hydraulic or pneumatic) is locked and cannot be switched on. Depressurize and purge any pressure relief valve and/or shaft seal flushing system. Check that any other associated equipment is turned off and disconnected. Allow the pump and components to cool down to a safe handling temperature.



- Do not attempt to dismantle a safety/pressure relief valve whose spring pressure has not been relieved, is connected to a pressurized gas/air supply or mounted on a pump in operation. Serious personal injury and/or damage to the pump may occur.



- Do not attempt to loosen or remove the pump cover, connections to the pump, shaft seal housings, pressure/temperature control devices or other components until you are sure that such actions will not lead to the unsafe escape of any pressurized media.

ATTENTION

- The pump installation must allow for safe routine maintenance and inspection (check for leakage, change of lubricants, pressure monitoring, etc) and provide adequate ventilation to prevent overheating.



- Pumps and/or drive units can produce sound levels in excess of 85dB(A) under unfavorable operating conditions. When necessary, personal protection against noise must be used. See the curves for sound levels in "Section 3.7".



- Avoid any contact with hot parts of the pumps or drive units which may cause personal injury. If the surface temperature of the system exceeds 60°C, the system must be marked with a warning sign of "hot surface". Operating conditions with temperature control devices (jacketed, electrically heated, etc), bad installation or poor maintenance can promote unnormally high temperatures on pumps and/or drive units.

ATTENTION

- When cleaning, either manually or by CIP method, the operator must ensure that a suitable procedure is used in accordance with the system requirements. During a CIP cleaning cycle, a pump differential pressure of between 2 and 3 bar is recommended to ensure that suitable velocities are reached in the pump head. The exterior of the pumps should be cleaned periodically.

Pumps must always be installed and operated in compliance with prevailing national and local health and safety regulations and legislation. The pump must be completely isolated from the pipe work and drive motor before any maintenance work is to be undertaken. In the event of hazardous products the system, as well as the pump, must be drained. Never operate the pump without the pump cover.

Always follow all applicable safety measures when manually cleaning the pump:

- Drive unit must be shut down so that it cannot be started.
- Any compressed air controlled, mounted safety relief valve must be closed and depressurized.
- Connections to flushed mechanical seals must be closed and depressurized.
- The pump and pipe work must be drained and depressurized.

Equipment that is incorrectly installed, operated in a dangerous manner or is poorly maintained poses a potential safety hazard. If all reasonable safety measures are not followed, serious personal injury and material damage may occur.

1.3.2 Pump units

1.3.2.1 Pump unit handling

Use an overhead crane, forklift or other suitable lifting device.

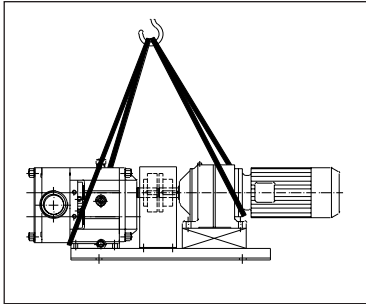

Secure lifting slings around the front part of the pump and the back part of the motor. Make sure that the load is balanced before attempting the lift.

NB! Always use two lifting slings.

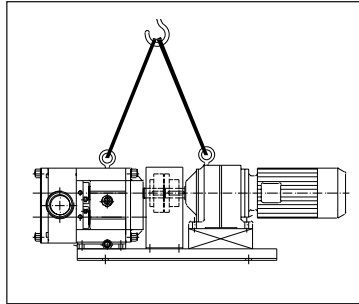

If there are lifting rings on both the pump and the motor the slings may be fastened to these.

NB! Always use two lifting slings.

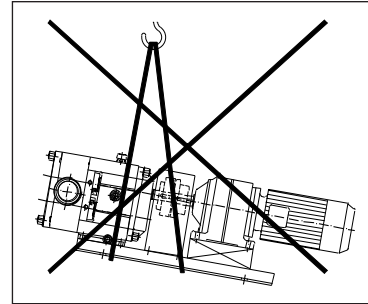

Warning

Never lift the pump unit with only one fastening point. Incorrect lifts can result in personal injury and/or damage to the unit.

1.3.2.2 Installation

All pump units should be equipped with a locking safety switch to prevent accidental start during installation, maintenance or other work on the unit.



Warning

The safety switch must be turned to off and locked before any work is carried out on the pump unit. Accidental start can cause serious personal injury.

The pump unit must be mounted on a level surface and either be bolted to the foundation or be fitted with rubber-clad feet.

The pipe connections to the pump must be stress-free mounted, securely fastened to the pump and well supported. Incorrectly fitted pipe can damage the pump and the system.



Warning

Electric motors must be installed by authorized personnel in accordance with EN60204-1. Faulty electrical installation can cause the pump unit and system to be electrified, which can lead to fatal injuries.

Electric motors must be supplied with adequate cooling ventilation. Electric motors must not be enclosed in airtight cabinets, hoods etc.

Dust, liquids and gases which can cause overheating and fire must be diverted away from the motor.



Warning

Pump units to be installed in potentially explosive environments must be fitted with an Ex-class (explosion safe) motor. Sparks caused by static electricity can give shocks and ignite explosions. Make sure that the pump and system are properly grounded. Check with the proper authorities for the existing regulations. A faulty installation can lead to fatal injuries.

1.3.2.3 Before commissioning the pump unit

Read the pump's operating and safety manual. Make sure that the installation has been correctly carried out according to the relevant pump's manual.

Check the alignment of the pump and motor shafts. The alignment may have been altered during transport, lifting and mounting of the pump unit. For safe disassembly of the coupling guard see below: Disassembly/assembly of the coupling guard.



Warning

The pump unit must not be used with other liquids than those for which it was recommended and sold. If there are any uncertainties contact your supplier. Liquids, for which the pump is not appropriate, can damage the pump and other parts of the unit as well as cause personal injury.

1.3.2.4 Disassembly/assembly of the coupling guard

The coupling guard is a fixed guard to protect the users and operator from fastening and injuring themselves on the rotating shaft/shaft coupling. The pump unit is supplied with factory mounted guards with certified maximum gaps in accordance with standard DIN EN ISO 13857.



Warning

The coupling guard must never be removed during operation. The locking safety switch must be turned to off and locked. The coupling guard must always be reassembled after it has been removed. Make sure to also reassemble any extra protective covers. There is a risk of personal injury if the coupling guard is incorrectly mounted.

- a) Turn off and lock the power switch.
- b) Disassemble the coupling guard.
- c) Complete the work.
- d) Reassemble the coupling guard and any other protective covers. Make sure that the screws are properly tightened.

1.3.2.5 Name plate – CE Declaration of Conformity

Always quote the serial number on the name plate together with questions concerning the pump unit, installation, maintenance etc.

When changing the operating conditions of the pump please contact your supplier to ensure a safe and reliable working pump.

This also applies to modifications on a larger scale, such as a change of motor or pump on an existing pump unit.

1.4 Pump designation - Full pump range

Example:

TW 2/ 0171- 40/ 06- W1 1- GB2 1- V V S
 1 2 3 4 5 6 7 8 9 10 11 12

1. Pump family name

TW = TopWing

2. Size of drive assembly

1, 2, 3, 4

3/4. Hydraulics indicated with displacement volume per revolution and connection diameter

	Displacement volume per revolution (in dm ³)	Inlet diameter	
		Standard pump	Enlarged inlet
TW1/0041	0.041	25	25/40
TW1/0082	0.082	25	25/40
TW2/0171	0.171	40	40/50
TW2/0343	0.343	50	50/80
TW3/0537	0.537	50	50/80
TW3/1100	1.100	80	80/100
TW4/1629	1.629	80	80/100
TW4/3257	3.257	100	100/150

5. Connection type

- 01 Hygienic threaded connection to DIN 11851/DIN 405
- 02 PN16 flanges to DIN 2633
- 04 Threaded connection to ISO 2853
- 05 Threaded connection for dairy industry BS 4825
- 06 SMS 1145 threaded connections
- 07 Clamp to ISO 2852
- 08 Flanges to ANSI B16,5 – 150 lbs
- 10 Gas thread ISO 7/1
- 11 DS 722 thread
- 12 Clamp to SMS 3017 (Triclamp)
- 13 NPT thread to ASA B2.1
- 14 Clamp to DIN 32676
- 15 Aseptic thread connection to DIN 11864-1
- 16 Aseptic flange connection to DIN 11864-2

6. Rotors

- W1 Bi-wing rotors in duplex stainless steel standard clearances
- M1 Multi-lobe rotors in duplex stainless steel standard clearances

Example:

TW 2/ 0171- 40/ 06- W1 1- GB2 1- V V S
1 2 3 4 5 6 7 8 9 10 11 12

7. Pump cover

- 1 Cover
- 2 Cover with safety relief valve spring loaded
- 3 Cover with safety relief valve spring loaded and air lifted
- 4 Cover with safety relief valve air loaded and air lifted
- 5 Cover with jacket
- 6 Cover with safety relief valve spring loaded and with jacket
- 7 Cover with safety relief valve spring loaded and air lifted and with jacket
- 8 Cover with safety relief valve air loaded and air lifted and with jacket

8. Seals

- GW1 Single mechanical seal SiC to SiC
- GB1 Single mechanical seal SiC to Carbon
- GW2 Single mechanical seal SiC to SiC with flushing
- GB2 Single mechanical seal SiC to Carbon with flushing
- DW2 Double mechanical seal SiC to SiC to Carbon
- DB2 Double mechanical seal Carbon to SiC to Carbon
- O1 Single O-ring seal
- DO2 Double O-ring seal with flushing

9. Feet

- 1 Horizontal connections – top drive
- 2 Horizontal connections – bottom drive
- 3 Vertical connections right hand drive from shaft end
- 4 Vertical connections left hand drive from shaft end

10. Kits for different O-ring material for hydraulic part

- V FPM
- E EPDM
- VF FPM - FDA
- EF EPDM - FDA
- T PTFE lined O-rings
- C Chemraz®
- K Kalrez®**)
- EP Full certified EPDM *)
- PP Full certified Perfluor *)
- FP Full certified FPM *)

11. Kits for different O-ring material for seal

- V FPM
- E EPDM
- VF FPM - FDA
- EF EPDM - FDA
- C Chemraz®
- K Kalrez®**)
- EP Full certified EPDM *)
- PP Full certified Perfluor *)
- FP Full certified FPM *)

12. Special execution

For details please contact your supplier.
Position deviating from standard marked with X.

*) Full certified O-rings = Includes certificates FDA, 3A, USP Class VI and AFO, not available for O-ring seals types O1 and DO2 as well as not for safety relief valves

**) Kalrez is a registered trademark of DuPont Performance Elastomers

1.5 Pump designation - EHEDG approved pumps

Example:

TW 2/ 0171- 40/ 06- W1 1- GB2 1- V V S
 1 2 3 4 5 6 7 8 9 10 11 12

1. Pump family name

TW = TopWing

2. Size of drive assembly

1, 2, 3, 4

3/4. Hydraulics indicated with displacement volume per revolution and connection diameter

	Displacement volume per revolution (in dm ³)	Inlet diameter	
		Standard pump	Enlarged inlet
TW1/0041	0.041	25	25/40
TW1/0082	0.082	25	25/40
TW2/0171	0.171	40	40/50
TW2/0343	0.343	50	50/80
TW3/0537	0.537	50	50/80
TW3/1100	1.100	80	80/100
TW4/1629	1.629	80	80/100
TW4/3257	3.257	100	100/150

5. Connection type

- 01 Hygienic threaded connection to DIN 11851 with SKS inner gasket set in EPDM or FKM
- 04 Threaded connection to ISO 2853 in combination with T-seals
- 07 Clamp to ISO 2852 in combination with Tri-Clamp seals
- 15 Aseptic threaded connection to DIN 11864-1
- 16 Aseptic flanged connection to DIN 11864-2

6. Rotors

- W1 Bi-wing rotors in duplex stainless steel standard clearances
- M1 Multi-lobe rotors in duplex stainless steel standard clearances

7. Pump cover

- 1 Cover
- 5 Cover with jacket

Example:

TW 2/ 0171- 40/ 06- W1 1- GB2 1- V V S
1 2 3 4 5 6 7 8 9 10 11 12

8. Seals

GW1 Single mechanical seal SiC to SiC
GB1 Single mechanical seal SiC to Carbon
GW2 Single mechanical seal SiC to SiC with flushing
GB2 Single mechanical seal SiC to Carbon with flushing
DW2 Double mechanical seal SiC to SiC to Carbon
DB2 Double mechanical seal Carbon to SiC to Carbon

9. Feet

3 Vertical connections right hand drive from shaft end
4 Vertical connections left hand drive from shaft end

10. Kits for different O-ring material for hydraulic part

EF EPDM - FDA
VF FPM - FDA
EP Full certified EPDM *)
FP Full certified FPM *)

11. Kits for different O-ring material for seal

EF EPDM - FDA
VF FPM - FDA
EP Full certified EPDM *)
FP Full certified FPM *)

12. Special execution

For details please contact your supplier.
Position deviating from standard marked with X.

*) Full certified O-rings = Includes certificates FDA, 3A, USP Class VI and AFO, not available for O-ring seals types O1 and DO2 as well as not for safety relief valves

1.6 Pump designation - 3-A approved pumps

Example:

TW 2/ 0171- 40/ 06- W1 1- GB2 1- V V S
 1 2 3 4 5 6 7 8 9 10 11 12

1. Pump family name

TW = TopWing

2. Size of drive assembly

2, 3, 4

3/4. Hydraulics indicated with displacement volume per revolution and connection diameter

	Displacement volume per revolution (in dm ³)	Inlet diameter	
		Standard pump	Enlarged inlet
TW2/0171	0.171	40	40/50
TW2/0343	0.343	50	50/80
TW3/0537	0.537	50	50/80
TW3/1100	1.100	80	80/100
TW4/1629	1.629	80	80/100
TW4/3257	3.257	100	100/150

5. Connection type

- 04 Threaded connection to ISO 2853
- 07 Clamp to ISO 2852
- 14 Clamp to DIN 32676
- 15 Aseptic thread connection to DIN 11864-1
- 16 Aseptic flange connection to DIN 11864-2

***Approved provided that a special packing giving self-centering ability is used.
Please contact your supplier for details***

- 01 Hygienic threaded connection to DIN 11851/DIN 405
- 05 Threaded connection for dairy industry BS 4825
- 12 Clamp to SMS 3017 (Triclamp)

6. Rotors

- W1 Bi-wing rotors in duplex stainless steel standard clearances
- M1 Multi-lobe rotors in duplex stainless steel standard clearances

7. Pump cover

- 1 Cover
- 5 Cover with jacket

Example:

<u>TW</u>	<u>2/</u>	<u>0171-</u>	<u>40/</u>	<u>06-</u>	<u>W1</u>	<u>1-</u>	<u>GB2</u>	<u>1-</u>	<u>V</u>	<u>V</u>	<u>S</u>
1	2	3	4	5	6	7	8	9	10	11	12

8. Seals

GW1 Single mechanical seal SiC to SiC
GB1 Single mechanical seal SiC to Carbon

9. Feet

1 Horizontal connections – top drive
2 Horizontal connections – bottom drive
3 Vertical connections right hand drive from shaft end
4 Vertical connections left hand drive from shaft end

10. Kits for different O-ring material for hydraulic part

EP Full certified EPDM *)
PP Full certified Perfluor *)
FP Full certified FPM *)

11. Kits for different O-ring material for seal

EP Full certified EPDM *)
PP Full certified Perfluor *)
FP Full certified FPM *)

12. Special execution

For details please contact your supplier.
Position deviating from standard marked with X.

*) *Full certified O-rings = Includes certificates FDA, 3A, USP Class VI and AFO, not available for O-ring seals types O1 and DO2 as well as not for safety relief valves*

1.7 Pump model and serial number

If you require further information regarding the TopWing pumps, please contact your supplier quoting the pump model and serial number. This information is stated on the name plate which is attached to the rotor case. If the name plate is damaged or missing, the serial number is also stamped on the rotor case under the endcover.

1.8 Pump standard parts

To avoid mistakes kindly always use the following terms for the different pump parts:

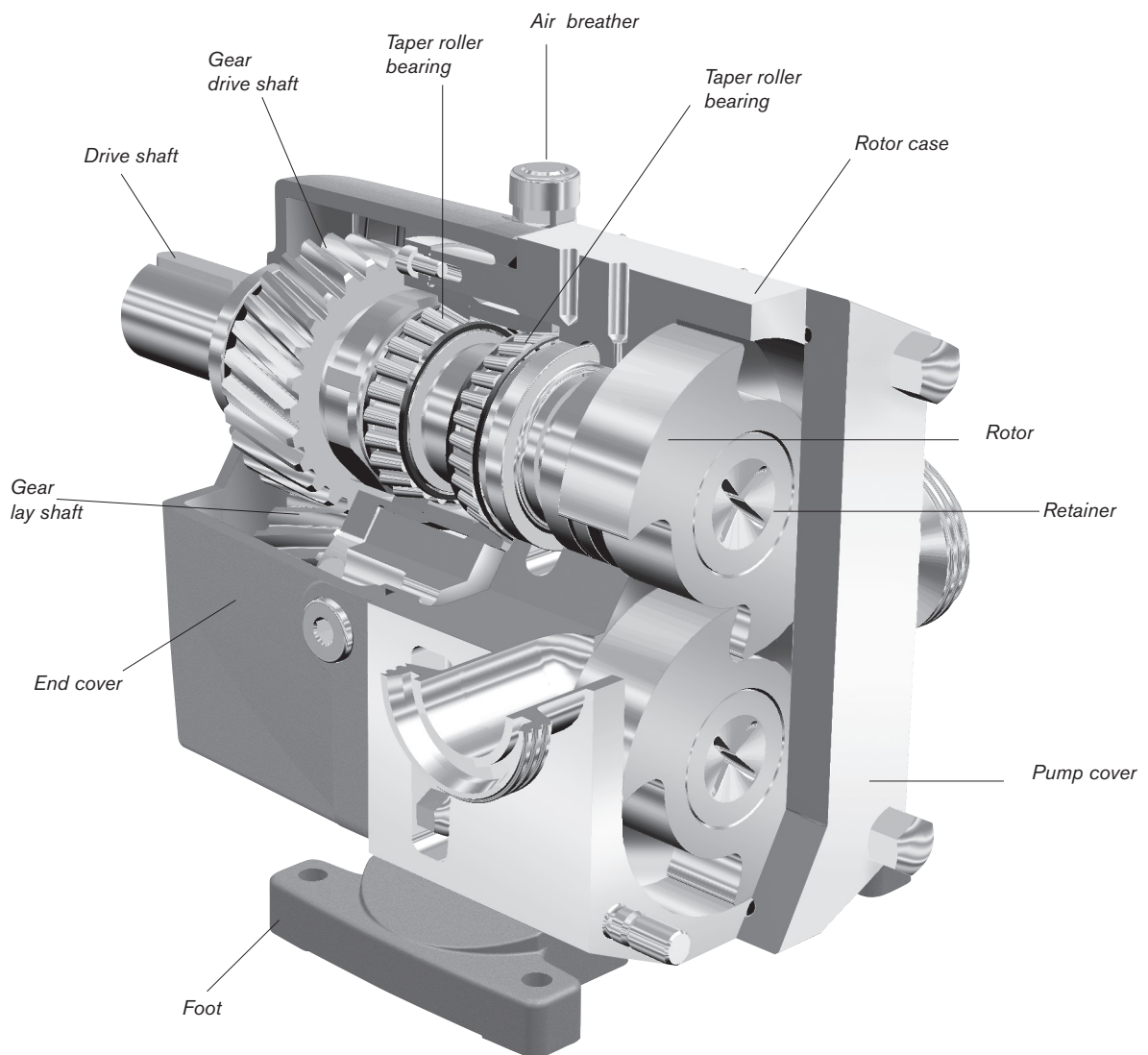

2.0 Function, construction, installation

2.1 Operating principle

The pumping action of the TopWing is achieved by the contra rotation of two rotors within a rotor case. The rotors are mounted on shafts, which are supported by tapered roller bearings, integrated in the rotor case. The second shaft is driven by the drive shaft via a set of timing gears that are fixed on the shaft by means of adjustable locking elements. The rotors are synchronized so that they rotate without contact with each other.

As the wings of the rotors move away from each other the volume between them increases, creating a decrease in pressure opposite the suction port (see fig. a). This causes the media to flow into the rotor case.

The pumped media is carried around the rotor case (see fig. b and c) to the discharge side of the pump (see fig. d). As the wings of the rotors move towards each other, the volume between them decreases, causing a rise in pressure opposite the discharge port. This causes the media to be pressed out of the rotor case (see fig. e).

Regarding the pump standard parts, see section 1.8.

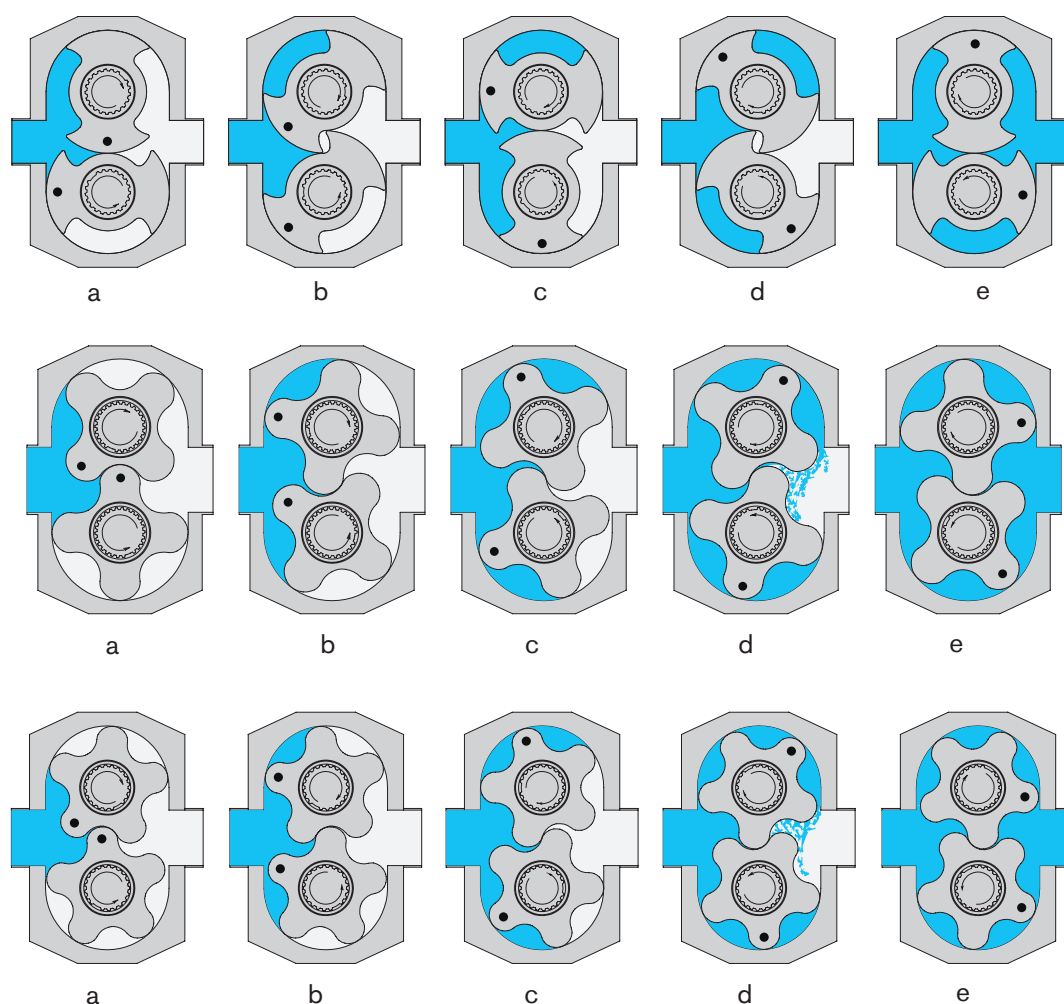

2.2 Operating parameters

The maximum pressure and speed operating data are given in the table below.

In practice these performance data can be limited by the nature of the pumped media and/or the design of the system in which the pump is installed.

2.2.1 Operating parameters Bi-wing rotors

Pump type	max pump speed [rpm]	swept volume [dm ³]	theoretical capacity at max speed and $\Delta p = 0$ bar [m ³ /h]	max differential pressure [bar]	max operating pressure [bar]	max torque on shaft end [Nm]	max liquid temperature °C
TW1/0041	1400	0.041	3.4	15	18	55	150
TW1/0082	1400	0.082	6.9	7	10	55	150
TW2/0171	1200	0.171	12.3	15	18	400	150
TW2/0343	1200	0.343	24.7	7	10	400	150
TW3/0537	1000	0.537	32.2	15	18	800	150
TW3/1100	1000	1.100	66.0	7	10	800	150
TW4/1629	800	1.629	78.2	15	18	2000	150
TW4/3257	800	3.257	156.3	7	10	2000	150

max pump speed	= n_{\max}
swept volume	= V_i
theoretical capacity at max speed and $\Delta p = 0$ bar	= $Q_{th_{\max}}$
max differential pressure	= Δp_{\max}
max operating pressure	= p_{\max}
max torque on shaft end	= T_{\max}

2.2.2 Operating parameters Multi-lobe rotors

Pump type	max pump speed [rpm]	swept volume [dm ³]	theoretical capacity at max speed and $\Delta p = 0$ bar [m ³ /h]	max differential pressure [bar]	max operating pressure [bar]	max torque on shaft end [Nm]	max liquid temperature °C
TW1/0041	1400	0.042	3.5	15	18	55	150
TW1/0082	1400	0.083	7.0	7	10	55	150
TW2/0171	1200	0.180	12.9	15	18	400	150
TW2/0343	1200	0.360	25.9	7	10	400	150
TW3/0537	1000	0.560	33.6	15	18	800	150
TW3/1100	1000	1.120	67.2	7	10	800	150
TW4/1629	800	1.742	83.6	15	18	2000	150
TW4/3257	800	3.483	167.2	7	10	2000	150

max pump speed	= n_{\max}
swept volume	= V_i
theoretical capacity at max speed and $\Delta p = 0$ bar	= $Q_{th_{\max}}$
max differential pressure	= Δp_{\max}
max operating pressure	= p_{\max}
max torque on shaft end	= T_{\max}

The pump is not to be exposed to rapid temperature changes to avoid damage through sudden expansion/contraction of the pump components.

Pumps for handling abrasive liquids (causing wear) should be selected with care. Please contact your supplier for advice.

Important!

If it is proposed to modify the system/duty or to use the pump for transporting liquids with other characteristics than for which the pump was originally selected always consult your supplier.

2.3 System design and installation

When a pump is to be incorporated in a system, it is considered good practice to, as far as possible, minimise the length of the pipes and the number of pipe fittings (tees, unions, bends etc.) and the restrictions. When designing the suction lines, particular care should be taken. These should be as short and straight as possible, using a minimum of pipe fittings to achieve a good product flow to the pump. Always consider the following when designing a system:



1. Ensure there is space enough around the pump to allow for:
 - a) Routine check and maintenance of the complete pump unit, seal area, drive motor, etc.
 - b) Good ventilation for the drive to avoid overheating.

ATTENTION

2. Both the suction and the discharge ports must be provided with valves. During check-up procedures or maintenance work, the pump must be isolated from the system.
3. The system design, pipes and other equipment must have independent supports to avoid heavy loads on the pump. In the case of pipe work or other equipment relying on the pump fixings for support, there is a big risk for serious damage to the pump.



4. For positive displacement pumps as TopWing it is recommended to install some safeguards, for example:
 - a) Built-on safety relief valves
 - b) External pressure relief valve system for recirculation to tank or suction side of the pump.
 - c) Torque device in the system, mechanical or electrical.
 - d) Rupture disc in the discharge pipework.

If the system can be ruined by reversed flow direction, safeguards must be considered for both directions of rotation/flow.

ATTENTION

5. It is considered good practice to thoroughly clean all pipework and associated equipment from the suction port to the discharge port before installation of pump. This is to avoid the risk of debris entering the pump and causing damage.

ATTENTION

6. If possible, pressure gauges should be placed at the suction port and the discharge port of the pump, so that the system pressures can be monitored. These gauges give a clear indication of changes in the operating conditions. If a relief valve is incorporated in the system the gauges will be necessary for setting and checking the function of the valve.

ATTENTION

7. It is very important that the suction condition at the pump inlet meets the NPSH required of the pump. Failure to observe this can cause cavitation, which leads to a noisy operation, reduced flow and mechanical damage on the pump and associated equipment.





ATTENTION

The NPSH available from the system must always exceed the NPSH required by the pump. If the following guidelines are observed it should ensure the best possible suction conditions.

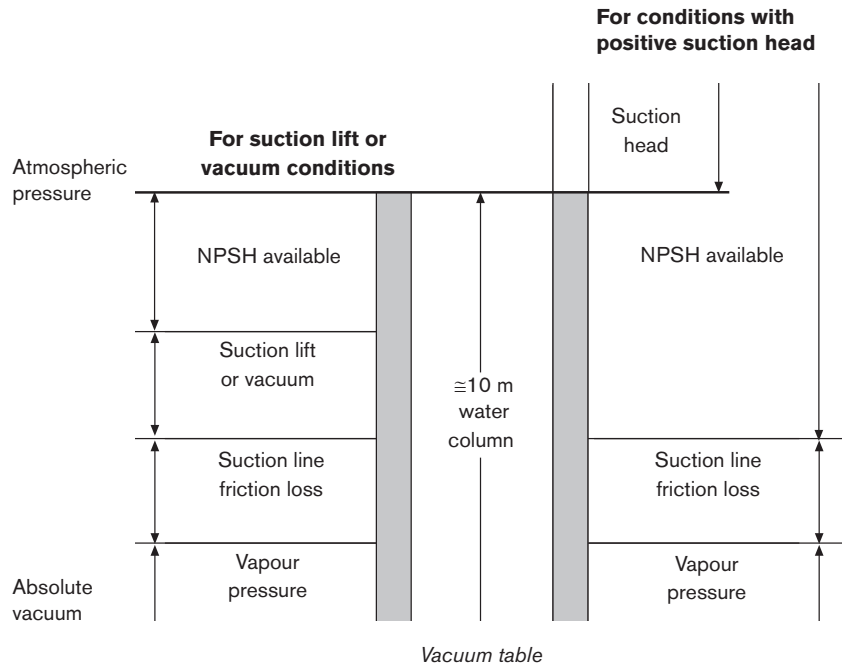
- The suction line should have at least the same diameter as the pump connections.
- The suction line should be as short as possible.
- Use a minimum of bends, tees and pipework restrictions.
- The calculations to determine the NPSH available from the system should be carried out for the worst condition, see vacuum table.
- If a filter is used on the suction pipe, check pressure drop at the actual flow.
This is important to avoid cavitation which can damage the pump.

Please contact your supplier if you require information on the pump or system NPSH characteristics.



8. When installing a pump complete with drive motor and baseplate the following guidelines must be observed:
- a) The most suitable drive for the TopWing pumps is to use a motor with direct coupling. Please contact your supplier if using some other method.
 -  b) Flexible couplings must always be used and aligned correctly within the limits recommended by the coupling manufacturer. Turn the shaft at least one full rotation to control the alignment of the coupling and that the shaft rotates smoothly.
 -  c) Couplings must always be enclosed in a suitable guard to prevent contact with rotating parts which could cause personal injury. Such guards must be of suitable material - see point d - and be of sufficiently rigid design to prevent contact with the rotating parts during normal operation.
 -  d) When installing pump sets in flammable or explosive environments or for handling flammable or explosive media, special consideration must be given not only regarding the security of the drive unit enclosure, but also for the materials used both in couplings and guards to eliminate the risk of explosion.
 -  e) The base plate must be secured to a flat level surface to avoid misalignment and distortion. When the baseplate is fastened in position, the alignment must be checked again, see point b.
 -  f) If the pump is driven by an electric motor, check that the motor and other electrical equipment are compatible with the drive and that the wiring is correct, i.e. Direct On-Line, Star Delta etc. Ensure that all components are correctly electrically grounded.

2.3.1 Installations with CIP-systems, Cleaning In Place



The TopWing pumps are constructed so that they easily can be cleaned with CIP-methods for cleaning of processing plants. To achieve the necessary fluid velocities within the pump when cleaning we recommend a differential pressure of 2-3 bars across the pump.

Recommendation: A built-on safety relief valve, spring loaded-air lifted, creates the possibility to achieve the flow in the pipe work after the pump without using separate CIP-valves and a by-pass connection.

2.3.2 Installations with SIP-systems, Sterilising In Place

TopWing pumps are capable of handling a SIP-process. Contact your local supplier for information regarding the temperatures needed for the process, as temperature has an effect on the clearances in the pump.

Equipment components may need sterilising, i.e. heating to high temperatures (up to 140°C) to kill organisms still remaining on the surface of the equipment. Sterilising is done by using steam or pressurised, heated water.

2.4 Start



- Make sure that all associated equipment is clean and free from debris and that all pipe connections are secure and correctly sealed.



- For pumps fitted with flushed product seals check that all required services for flushing purposes are in place and connected. They must give sufficient flow and pressure for the flushing purposes. Contact your local supplier for advice. For seal plans, see chapter 10.



- Check the lubrication for the pump and drive. The TopWing pumps are delivered without oil and should be filled to the level of the oil level glass. See "Section 3.3" regarding pump oil capacities and grades.



- If an external relief valve is incorporated in the system, check that it is set correctly. It is considered good practice to set the relief valve lower than the system design pressure. After commissioning, the relief valve should be reset to the required setting for the application. The required setting should never exceed the lower of either the pumps maximum pressure rating or the system design pressure.



- Check that the valves are completely open on both the inlet and outlet and that the pipelines are free from obstructions. The TopWing pumps are of the positive displacement type and should therefore never be operated against a closed valve, as this would result in pressure overload, damages on the pump and possibly damage on the pump system.



- Check that the drive shaft has the correct direction of rotation for required flow, see figure below.

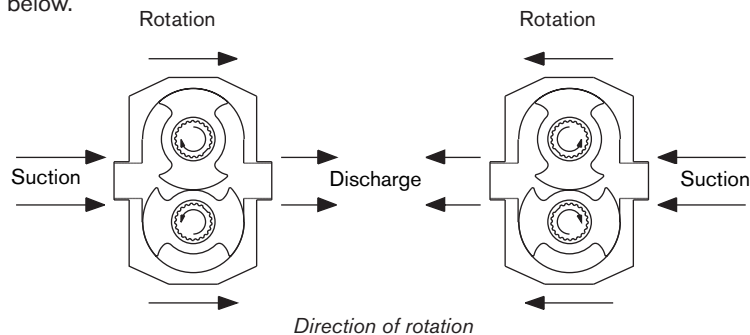

- Before starting the pump, make sure that there is liquid on the suction side. This is very important for pumps with unflushed product seals as these sealing arrangements must never run dry.
- Before operating the pump it is considered good practice to briefly start and stop the pump to check the direction of rotation and to make sure that there are no obstructions what so ever for the function. When this has been done the operation can begin. Keep a visual check on the suction and discharge pressure gauges and monitor the pump temperature and absorbed power where possible.

2.5 Shutdown



When shutting the pump down the valves on the suction and discharge side must be closed. Following precautions must be taken:

- The power is shut off and the starting device locked so that the pump cannot be started.
- The pneumatic relief valve is purged.
- The connections for the flushed mechanical seals are shut off and depressurised.
- The pump and pipelines must be empty and de-pressurised.

See chapter “4.0 Disassembly and assembly instructions” before undertaking any work on the pump.

2.6 Routine maintenance



- Check the oil level regularly.
- Change the oil once a year or every 3000 operating hours, whichever comes first.
- For lubricant capacities and grades, see “Section 3.3”.
- Measure vibration and temperature, these factors can indicate bearing failure.
- Regularly check for leakages

2.7 Typical CIP (Cleaning In Place) cycle

CIP relies on the circulation of fluid through the system at velocity and temperature. Velocity is required to generate turbulence in order to dislodge debris whilst temperature is required for the fluids to clean effectively.

Velocity is normally about 2 metres/second (6 feet/second). The need of velocity can depend on the pumped liquid, the process and the system to be cleaned. A centrifugal pump is often used to circulate the cleaning fluids as the required velocity is often beyond the scope of a PD pump. It is advised to have minimum 2 bar pressure over the PD pump during the CIP cycle.

The typical CIP cycle:

Step 1 Pre-rinse. Cold water – 5 minutes – removes product debris.

Step 2 Detergent wash. Normally sodium hydroxide (Caustic) alkaline based – 30 to 45 minutes at 75°C to 95°C – removes carbohydrates, proteins, fats.

Step 3 Rinse. Cold water – 5 minutes – removes detergent residues.

Step 4 Acid wash. Nitric or phosphoric acid – 15 to 30 minutes at 60°C – removes mineral salt residues and neutralizes.

Step 5 Final rinse. Cold water – 5 minutes – removes acid residues.

Cycle times, temperatures, fluids and concentrations of fluids used will vary depending on the product, process and system. Further, additional washes may be introduced.

2.8 Typical SIP (Sterilizing In Place) cycle

Sometimes referred to as “Steaming Through” or “Steaming In Place”.

Equipment components may need sterilizing, i.e. heating to high temperature (up to 140°C) to kill organisms still remaining on the surface of the equipment.

A typical SIP cycle:

Step 1 Pre-rinse. Cold water – 5 minutes – removes any debris.

Step 2 Sterilization. Steam condensate – 30 minutes at 121°C to 140°C kills off any remaining micro-organisms and spores.

Step 3 Nitrogen Purge. Nitrogen – 5 minutes – ambient – gives inert atmosphere.

Step 4 Solvent flush. Acetone, toluene, isopropyl alcohol – 5 minutes – ambient – dries system out.

These steps may be done more than once before use.

2.9 Trouble shooting chart

Symptom		Causes								Actions	
		Irregular flow	Low capacity	Pump overheats	Motor overheats	Excessive rotor wear	Excessive seal wear	Noise, Vibrations	Seizure		Pump stalls on start up
▪										Incorrect direction of rotation	Reverse motor
▪										Pump not primed	Expel gas from suction line/pump chamber and prime
▪	▪					▪				Insufficient NPHS available	Increase suction line dia and static suction head Simplify suction line and reduce length
	▪	▪						▪		Product vapourising in suction line	Reduce pump speed and product temperature
	▪	▪								Air entering suction line	Remake pipework joints
▪	▪	▪								Gas in suction line	Expel gas from suction line/pump chamber
	▪	▪								Insufficient static suction head	Raise product level to increase static suction head
			▪						▪	Product viscosity too high	Decrease pump speed/increase product temperature
										Product viscosity too low	Increase pump speed/decrease product temperature
					▪				▪	Product temperature too high	Cool product/pumping chamber
									▪	Product temperature too low	Heat product/pumping chamber
										Unexpected solids in product	Clean the system/fit strainer on suction side of pump
									▪	Discharge pressure too high	Check for blockages/simplify discharge line
										Rotor case strained by pipework	Check pipe alignment/support pipework
										Pump speed too high	Decrease pump speed
										Pump speed too low	Increase pump speed
										Seal flush inadequate	Increase seal flush to required pressure/flow
										Bearing/firming gear wear	Replace worn components

3.0 Technical data

3.1 Rotor clearances - Bi-wing rotors

Clearances for liquid temperature of max 150°C.

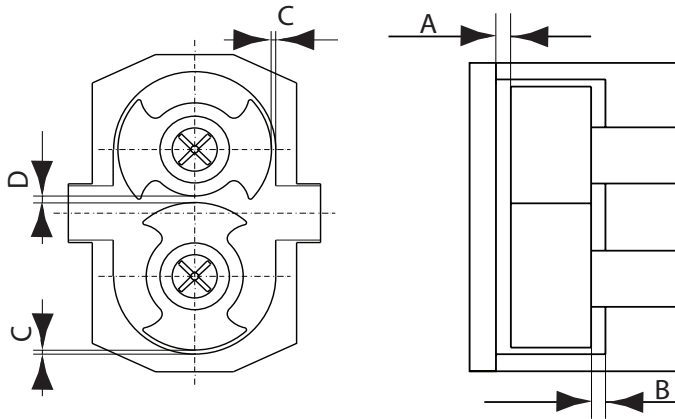

- A = Axial clearance rotor/pump cover
- B = Axial clearance rotor/back side rotor case
- C = Radial clearance rotor/rotor case top and side
- D = Clearance rotor/rotor

Standard rotor clearances - option W1

Pump type	A [mm]		B [mm]		C [mm]		D [mm]	
	min	max	min	max	min	max	min	max
TW1/0041	0.080	0.105	0.04	0.12	0.05	0.12	0.05	0.14
TW1/0082	0.100	0.125	0.05	0.14	0.08	0.15	0.07	0.16
TW2/0171	0.125	0.150	0.10	0.20	0.10	0.17	0.09	0.19
TW2/0343	0.135	0.160	0.11	0.20	0.12	0.20	0.12	0.21
TW3/0537	0.150	0.175	0.12	0.23	0.12	0.22	0.13	0.23
TW3/1100	0.165	0.190	0.14	0.25	0.14	0.24	0.15	0.25
TW4/1629	0.200	0.225	0.18	0.305	0.17	0.30	0.18	0.31
TW4/3257	0.225	0.250	0.22	0.34	0.20	0.33	0.22	0.35

3.2 Rotor clearances - Multi-lobe rotors

Clearances for liquid temperature of max 150°C.

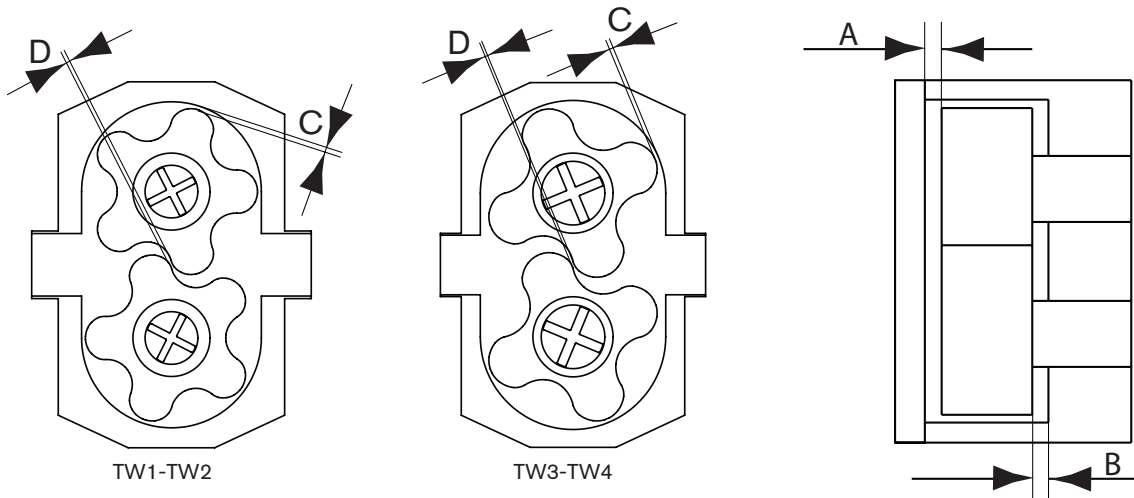

- A = Axial clearance rotor/pump cover
- B = Axial clearance rotor/back side rotor case
- C = Radial clearance rotor/rotor case top and side
- D = Clearance rotor/rotor

Standard rotor clearances - option M1

Pump type	A [mm]		B [mm]		C [mm]		D [mm]	
	min	max	min	max	min	max	min	max
TW1/0041	0.080	0.105	0.04	0.12	0.04	0.13	0.04	0.20
TW1/0082	0.100	0.125	0.05	0.14	0.07	0.16	0.07	0.23
TW2/0171	0.125	0.150	0.10	0.20	0.09	0.19	0.07	0.23
TW2/0343	0.135	0.160	0.11	0.20	0.11	0.21	0.12	0.28
TW3/0537	0.150	0.175	0.12	0.23	0.11	0.23	0.12	0.28
TW3/1100	0.165	0.190	0.14	0.25	0.13	0.25	0.17	0.33
TW4/1629	0.200	0.225	0.18	0.30	0.16	0.31	0.17	0.33
TW4/3257	0.225	0.250	0.22	0.34	0.19	0.34	0.23	0.39

3.3 Oil volume in gearboxes

Examples of FD/NSF H1 approved oils
▪ Shell Cassida Fluids GL
▪ Mobil DTEFM
▪ Castrol Optileb GT-range
▪ Texaco Cygnus gear PAO-range

Examples of non-food approved oils
▪ Shell Omala
▪ BP Energol
▪ Esso Spartan

Required characteristics	
Grade	Ambient operating temperature
ISO VG150	-18°C to 0°C
ISO VG 220	0°C to 30°C
ISO VG 320	30°C to 150°C

The pump will not be supplied pre-filled with oil therefore this table must be used to select recommended oil.

Oil changing: Oil level must be checked with the pump static.

First change: After 150 hours of operation, thereafter every 3000 hours of operation.

Oil filling: Fill with oil through the filler plug to the level indicated in the oil level glass.

Oil volume

Pump	Horizontal connection	Vertical connection
TW1	0.26 l	0.22 l
TW2	0.63 l	0.40 l
TW3	1.60 l	0.73 l
TW4	4.00 l	1.75 l

After filling up oil, check the oil level in the oil level glass.

Location of the oil level glass and the air breather

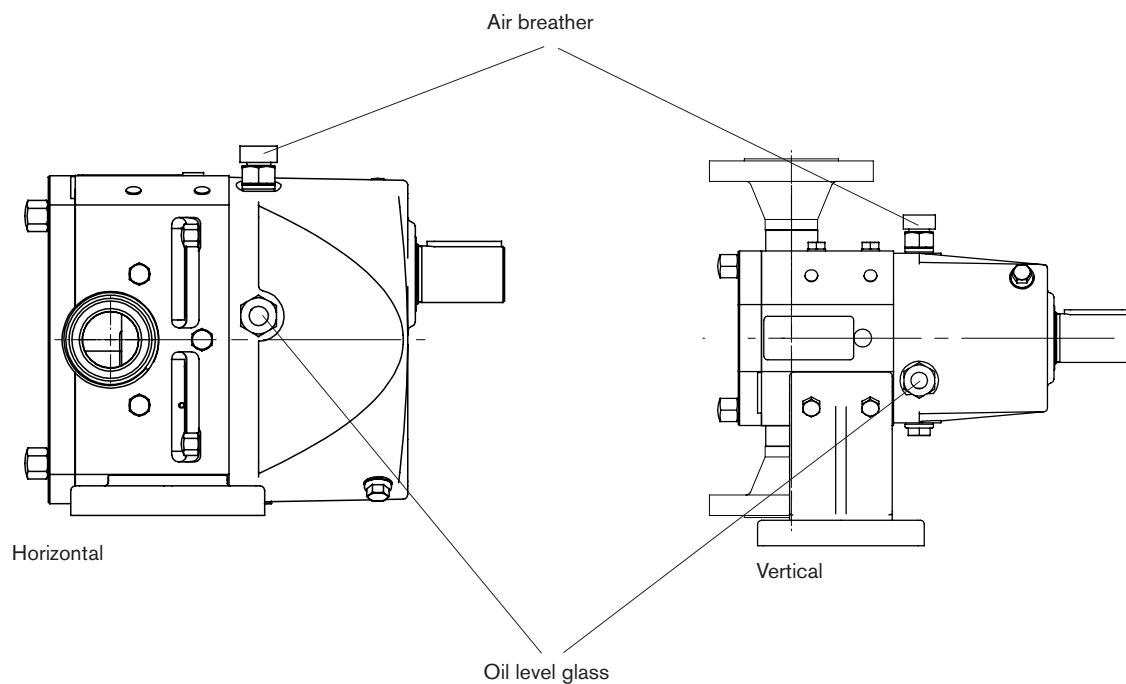

3.4 Material specification

3.4.1 Machined parts – Pump

Pos.	Description	Europe		USA	Pump type			
		EN/DIN	W.-nr.		TW1	TW2	TW3	TW4
0010	Rotor case	EN 10213-4	1.4409	A351 CF3M	X	X	X	X
0020	Rotor		1.4462	AISI 329	X	X	X	X
0030	Pump cover	EN 10088-3	1.4404	AISI 316L	X	X	X	X
0050	Drive shaft	EN 10088-3	1.4460	AISI 329	X	X	X	X
0051	Lay shaft							
0070	Foot	EN 10213-4	1.4308	A351 CF8	X	X	X	X
0120	End cover	EN 10213-4	1.4308	A351 CF8	X	X	X	X
0121	Bearing holder	EN 10083-1	1.1191	SAE 1045	X	X	X	X
0172	Pressure flange	EN 10083-1	1.1191	SAE 1045	X	–	–	–
0190	Gear, 1 pair	EN 10025-2	1.7131	SAE 2127	X	X	X	X
0250	Retainer		1.4462	AISI 329	X	X	X	X

Reference catalogue: Stahlschlüssel 2001 (steel page 250 – 256 / stainless steel page 492 – 494)

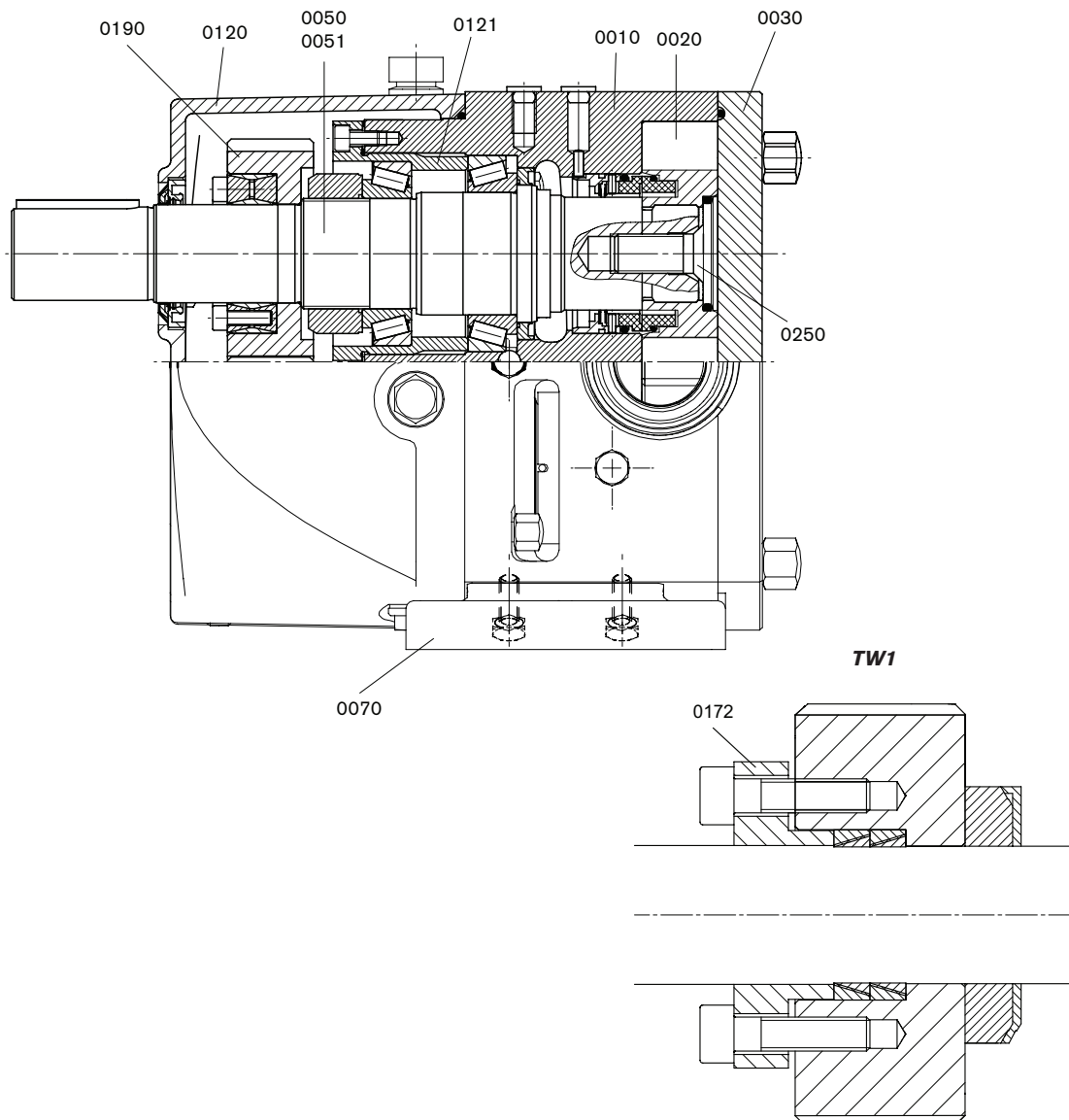

3.5 Dimensional drawings and weights

3.5.1 Standard

Connections, see 3.5.3

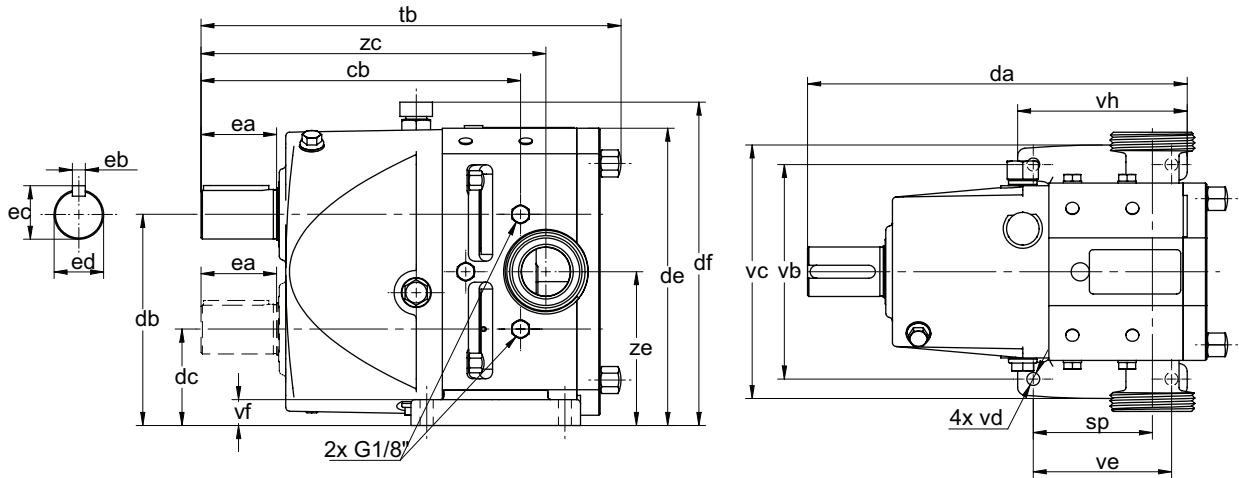

Pump shown with seal flush.
Broken line shaft shows position for bottom drive version.

All dimensions in mm

Pump type	cb	da	db	dc	de	df	ea	eb	ec	ed
TW1/0041	177	213	113.5	55.5	160.5	187	35	6	21.5	19
TW1/0082	177	213	113.5	55.5	160.5	187	35	6	21.5	19
TW2/0171	245	291	162	74	228	248	58	10	41	38
TW2/0343	245	291	162	74	228	248	58	10	41	38
TW3/0537	310	370	215.5	98.5	305.5	325	82	14	51.5	48
TW3/1100	310	370	215.5	98.5	305.5	325	82	14	51.5	48
TW4/1629	424	498.5	297	135	423	438.5	140	20	74.5	70
TW4/3257	424	498.5	297	135	423	438.5	140	20	74.5	70

Pump Type	sp	tb	vb	vc	vd	ve	vf	vh	zc	ze
TW1/0041	65.5	238	110	135	10	74	15	95	194	84.5
TW1/0082	80.5	258	110	135	10	74	15	95	209	84.5
TW2/0171	91.5	322	164.5	195	10	106	20	130	264	118
TW2/0343	116	353	164.5	195	10	106	20	130	289	118
TW3/0537	118	410	213	254	14	134	25	170	336	157
TW3/1100	148	455	213	254	14	134	25	170	366	157
TW4/1629	140.5	563	312	376	17.5	160	30	200	459	216
TW4/3257	184.5	627	312	376	17.5	160	30	200	503	216

Regarding dimensions and weights of separate valves, see chapter 11.0.

3.5.2 Vertical mounting

Connections, see 3.5.3

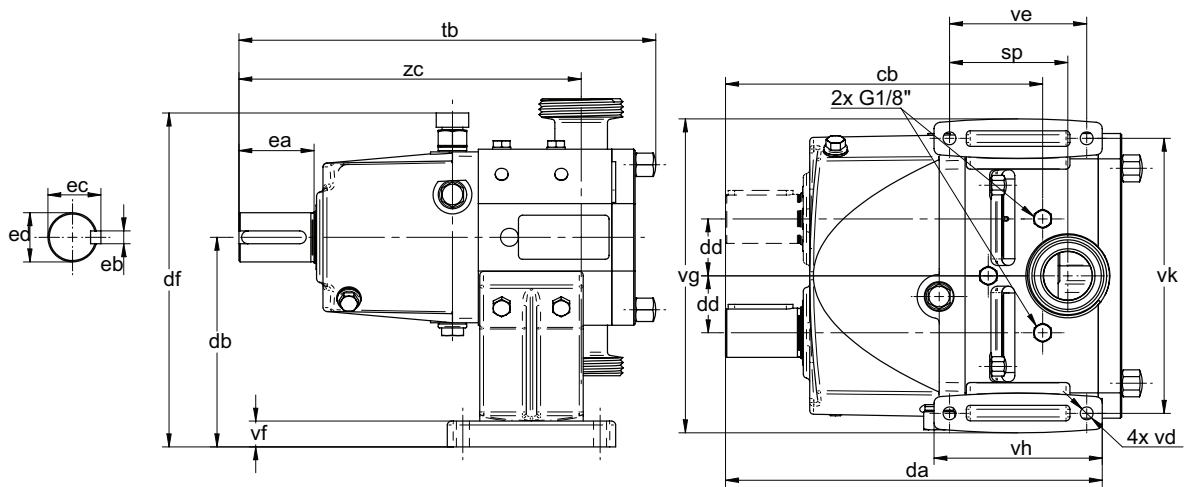

**Pump shown with seal flush.
Broken line shaft position for LH drive version.**

All dimensions in mm

Pump type	cb	da	db	dd	df	ea	eb	ec	ed	sp	tb	vd	ve	vf	vg	vh	vk	zc
TW1/0041	177	213	113.5	29	191.5	35	6	21.5	19	65.5	238	10	74	15	175	95	150.5	194
TW1/0082	177	213	113.5	29	191.5	35	6	21.5	19	80.5	258	10	74	15	175	95	150.5	209
TW2/0171	245	291	162	44	258	58	10	41	38	91.5	322	10	106	20	242.5	130	212.5	264.5
TW2/0343	245	291	162	44	258	58	10	41	38	116	353	10	106	20	242.5	130	212.5	289
TW3/0537	310	370	215.5	58.5	335	82	14	51.5	48	118	410	14	134	25	327	170	287	336
TW3/1100	310	370	215.5	58.5	335	82	14	51.5	48	148	455	14	134	25	327	170	287	366
TW4/1629	424	498.5	297	81	451	140	20	74.5	70	140.5	563	17.5	160	30	466	200	402	459
TW4/3257	424	498.5	297	81	451	140	20	74.5	70	184.5	627	17.5	160	30	466	200	402	503

Regarding dimensions and weights of separate valves, see chapter 11.0.

3.5.3 Connections

1 = All thread connections (DIN, SMS, DS, BS, ISO, GAS THREAD, NPT THREAD) and all clamp connections (ISO, SMS, DIN)

2 = All flanges DIN-PN16, DIN11864-2 Form A and ANSI (class 150)

3.5.3.1 Standard pump

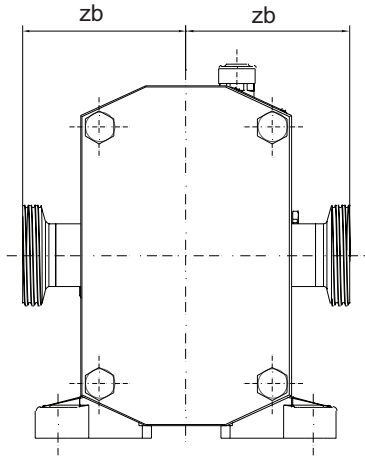

Pump type	1-zb	2-zb
TW1/0041	85	117
TW1/0082	85	117
TW2/0171	107	139
TW2/0343	107	139
TW3/0537	131	163
TW3/1100	136	168
TW4/1629	178	210
TW4/3257	182	212

All dimensions in mm

3.5.3.2 Enlarged inlet

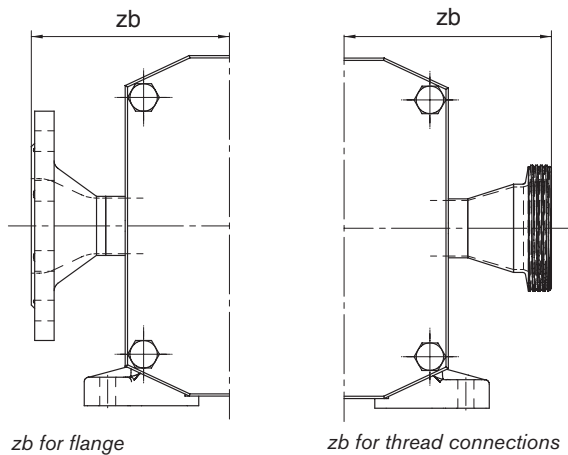

zb for flange

zb for thread connections

Pump type	Enlarged inlet	2-zb	1-zb
TW1/0041	25/40	117	125
TW1/0082	25/40	117	125
TW2/0171	40/50	139	147
TW2/0343	50/80	149	157
TW3/0537	50/80	173	181
TW3/1100	80/100	168	178
TW4/1629	80/100	210	220
TW4/3257	100/150	212	222

All dimensions in mm

3.5.4 Thread and clamp connections

Dimension table, see next page

Thread connections

DIN 11851/
DIN 405

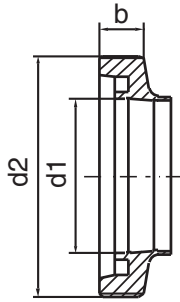

ISO 2853

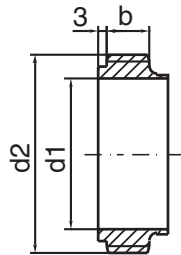

BS 4825

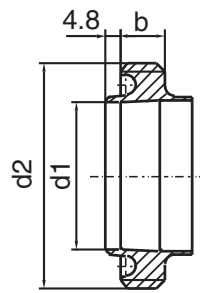

DIN 11864-1

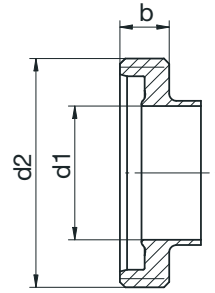

SMS 1145

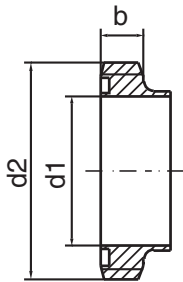

GAS THREAD

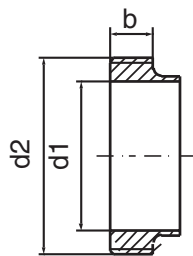

DS 722

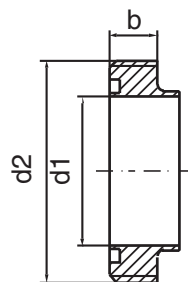

NPT THREAD

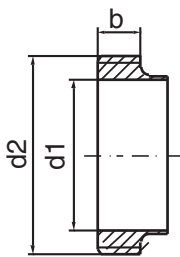

Clamp connections

ISO 2852

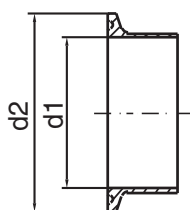

SMS 3017

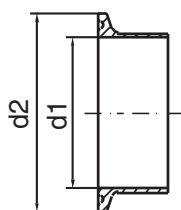

DIN 32676

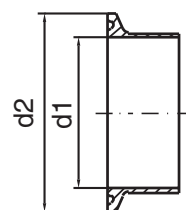

Dimensions – Thread and clamp connections

THREAD CONNECTIONS		TW1/0041	TW1/0082	TW2/0171	TW2/0343	TW3/0537	TW3/1100	TW4/1629	TW4/3257
DIN 11851/ DIN 405	d2	Rd 52x1/6	Rd 52x1/6	Rd 65x1/6	Rd 78x1/6	Rd 78x1/6	Rd 110x1/4	Rd 110x1/4	Rd 130x1/4
	d1	26	26	38	50	50	81	81	100
	b	14	14	14	14	14	20	20	20
DIN 11864-1 Form A	d2	Rd 52x1/6	Rd 52x1/6	Rd 65x1/6	Rd 78x1/6	Rd 78x1/6	Rd 110x1/4	Rd 110x1/4	Rd 130x1/4
	d1	26	26	38	50	50	81	81	100
	b	14	14	14	14	14	20	20	20
ISO 2853	d2 ±0.08	37.05	37.05	52.6	64.08	64.08	91.11	91.11	–
	d1	22.6	22.6	37.6	48.5	48.5	72	72	–
	b	13.5	13.5	13.5	13.5	13.5	13.5	13.5	–
BS 4825	d2 ±0.15	45.56	45.56	58.26	72.56	72.56	97.97	97.97	123.37
	d1	22.2	22.2	34.9	47.6	47.6	72	72	97.6
	b	14.3	14.3	14.3	14.3	14.3	14.3	14.3	14.3
SMS 1145	d2	Rd 40x1/6	Rd 40x1/6	Rd 60x1/6	Rd 70x1/6	Rd 70x1/6	Rd 98x1/6	Rd 98x1/6	Rd 132x1/6
	d1	22.6	22.6	35.5	48.5	48.5	72	72	97.6
	b	11	11	15	15	15	19	19	30
GAS THREAD ISO 7/1	d2	R 1"	R 1"	R 1 1/2"	R 2"	R 2"	R 3"	R 3"	R 4"
	d1	22.6	22.6	37.6	48.5	48.5	72	72	97.6
	b	14	14	14	14	14	20	20	20
DS 722	d2	Rd 44x1/6	Rd 44x1/6	Rd 58x1/6	Rd 72x1/6	Rd 72x1/6	Rd 100x1/6	Rd 100x1/6	–
	d1	22.6	22.6	35.5	48.5	48.5	72	72	–
	b	13.5	13.5	13.5	15.5	15.5	16.5	16.5	–
NPT THREAD ASA B 2.1	d2	1" NPT	1" NPT	1 1/2" NPT	2" NPT	2" NPT	3" NPT	3" NPT	4" NPT
	d1	22.6	22.6	37.6	48.5	48.5	72	72	97.6
	b	14	14	14	14	14	20	20	20

CLAMP CONNECTIONS									
ISO 2852	d2	50.5	50.5	64	64	64	91	91	119
	d1	22.6	22.6	37.6	48.5	48.5	72	72	97.6
SMS 3017	d2	50.5	50.5	50.5	64	64	91	91	119
	d1	22.6	22.6	35.6	48.5	48.5	72	72	97.6
DIN 32676	d2	50.5	50.5	50.5	64	64	106	106	119
	d1	26	26	38	50	50	81	81	100

All dimensions in mm

3.5.5 Industrial DIN and ANSI flanges - Non-hygienic

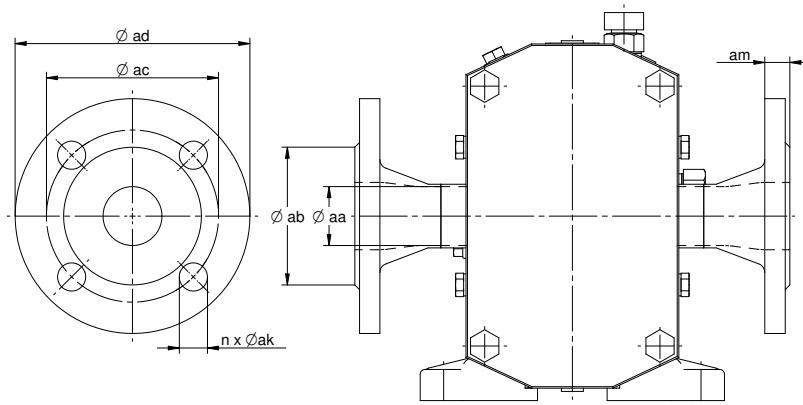

		TW1/0041	TW1/0082	TW2/0171	TW2/0343	TW3/0537	TW3/1100	TW4/1629	TW4/3257
aa		22.6	22.6	37.6	48.5	48.5	72	72	97.6
ab	PN16	68	68	88	102	102	138	138	158
	ANSI Class 150	50.8	50.8	73	92.1	92.1	127	127	157.2
ac	PN16	85	85	110	125	125	160	160	180
	ANSI Class 150	79.4	79.4	98.4	120.7	120.7	152.4	152.4	190.5
ad	PN16	115	115	150	165	165	200	200	220
	ANSI Class 150	108	108	127	152.4	152.4	190.5	190.5	228.6
nxøak	PN16	4xø14	4xø14	4xø18	4xø18	4xø18	8xø18	8xø18	8xø18
	ANSI Class 150	4xø15.9	4xø15.9	4xø15.9	4xø19.1	4xø19.1	4xø19.1	4xø19.1	8xø19.1
am	PN16	16	16	16	18	18	20	20	20
	ANSI Class 150	14.3	14.3	17.5	19.1	19.1	23.8	23.8	23.8

All dimensions in mm

3.5.6 Hygienic DIN 11864-2 Form A flanges

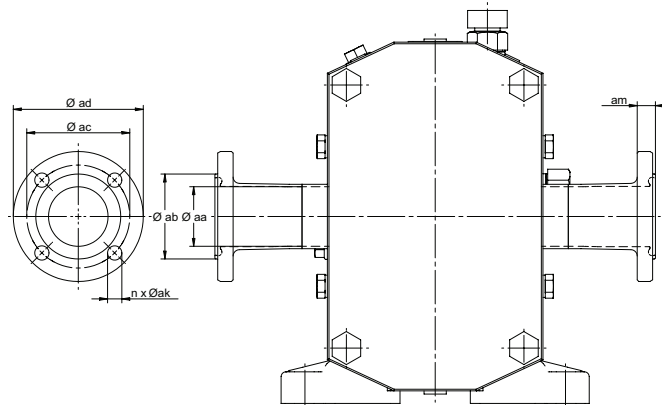

	TW1/0041	TW1/0082	TW2/0171	TW2/0343	TW3/0537	TW3/1100	TW4/1629	TW4/3257
aa	22.6	22.6	37.6	48.5	48.5	72	72	97.6
ab	38.3	38.3	53.6	65.6	65.6	97.6	97.6	116.6
ac	53	53	65	77	77	112	112	137
ad	70	70	82	94	94	133	133	159
nxøak	4xø9	4xø9	4xø9	4xø9	4xø9	8xø11	8xø11	8xø11
am	11.5	11.5	11.5	11.5	11.5	13.5	13.5	15.5

All dimensions in mm

3.6 Weights

3.6.1 Weights standard pump

Pump type	Standard pump weight	Vertical mounting weight
TW1/0041	14.5	15
TW1/0082	16.5	17
TW2/0171	38.5	40
TW2/0343	44	45.5
TW3/0537	87	90
TW3/1100	101	104
TW4/1629	245	252
TW4/3257	286	293

All weights in daN, mass is kg.

3.7 Sound level

3.7.1 Pumps with Bi-wing rotors

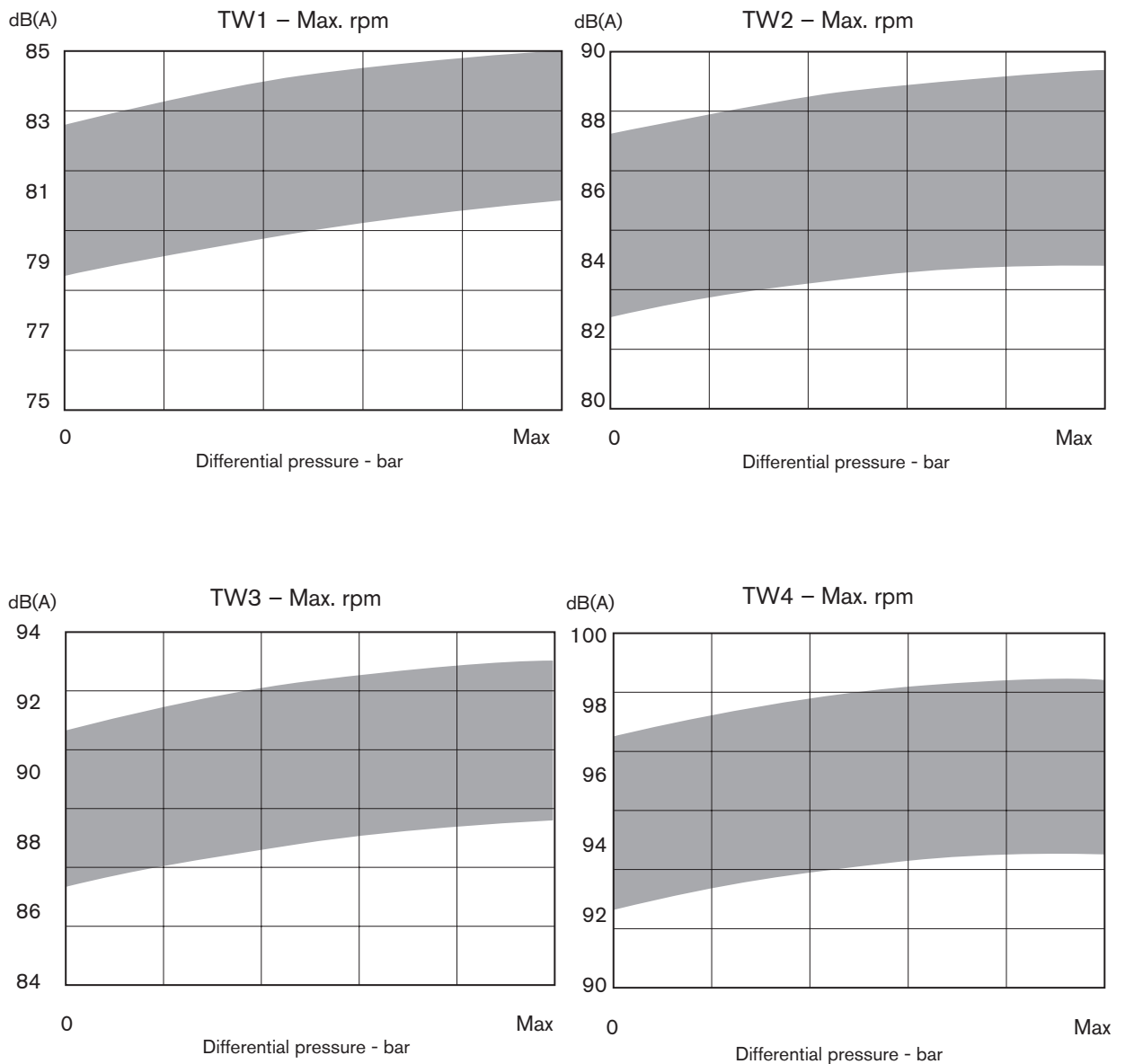

3.7.2 Pumps with Multi-lobe rotors

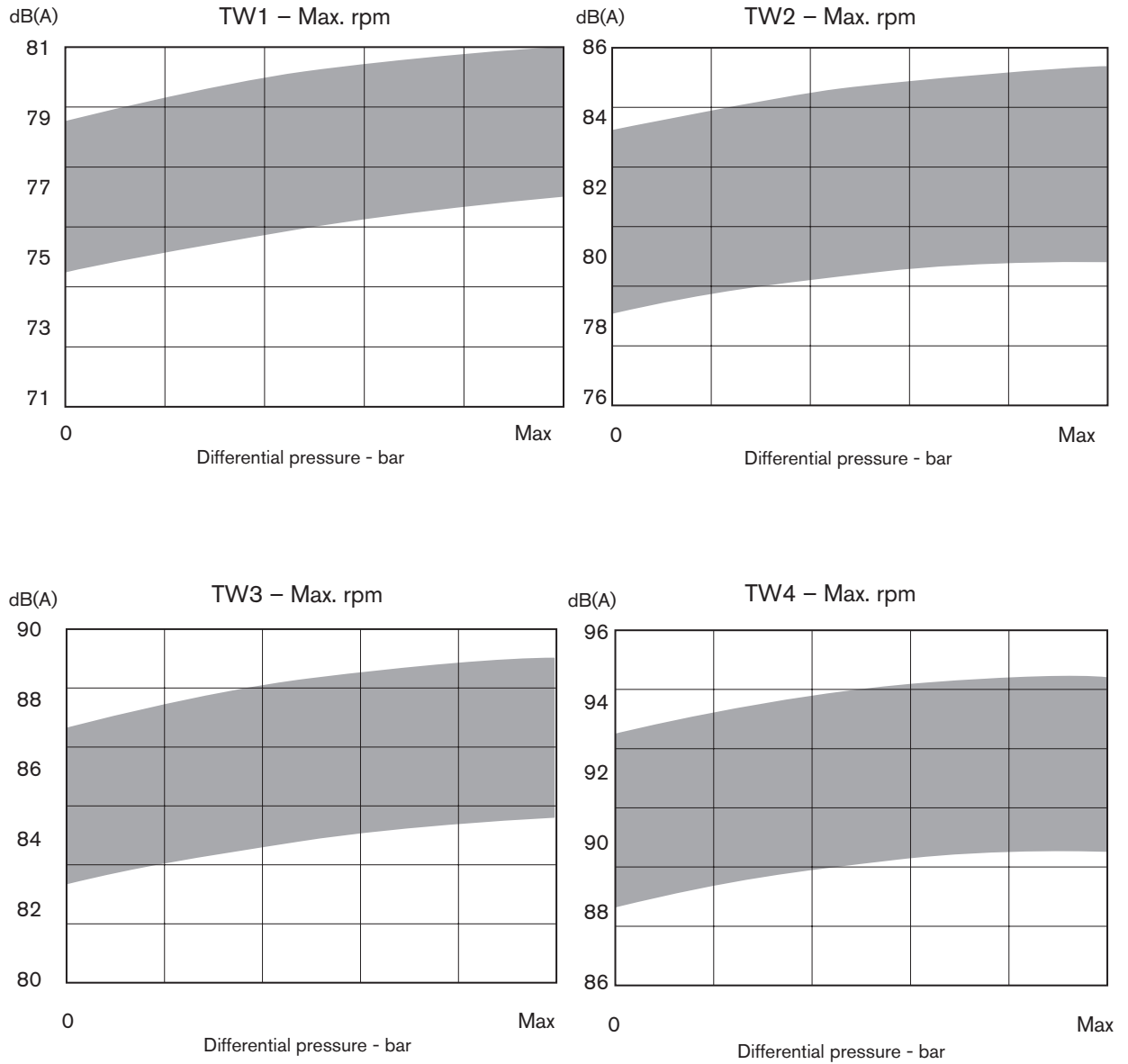

3.8 Solid particles

Pump type	Nominal internal diameter of connection (mm)	Max. theoretical particle size (mm)	Recommended max. particle size (mm)
TW1/0041	25	11	6
TW1/0082	25	11	6
TW2/0171	40	20	12
TW2/0343	50	20	12
TW3/0537	50	34	18
TW3/1100	80	34	18
TW4/1629	80	50	28
TW4/3257	100	50	28

4.0 Disassembly and assembly instructions

4.1 Tools to be used

Type	Size	TW1	TW2	TW3	TW4
Combination spanner	10 mm	X			
Combination spanner	13 mm	X	X		
Combination spanner	17 mm			X	
Combination spanner	19 mm	X	X	X	X
Combination spanner	22 mm	X	X	X	X
Combination spanner	24 mm			X	
Combination spanner	30 mm				X
Hexagon (Allen) key	4 mm	X			
Hexagon (Allen) key	5 mm		X		
Hexagon (Allen) key	6 mm	X	X	X	X
Hexagon (Allen) key	8 mm	X	X	X	X
Hexagon (Allen) key	10 mm				X
Hexagon (Allen) key - Socket driven	4 mm	X			
Hexagon (Allen) key - Socket driven	5 mm		X		
Hexagon (Allen) key - Socket driven	6 mm	X	X	X	X
Hexagon (Allen) key - Socket driven	10 mm	X	X	X	X
Hexagon key - Socket driven	13 mm	X	X		
Hexagon key - Socket driven	17 mm			X	
Hexagon key - Socket driven	19 mm	X	X	X	X
Hexagon key - Socket driven	22 mm	X	X	X	X
Hexagon key - Socket driven	24 mm			X	
Hexagon key - Socket driven	30 mm				X
Torque wrench	Adjustable up to min. xx Nm	X			
Torque wrench	Adjustable up to min. xx Nm		X		
Torque wrench	Adjustable up to min. xx Nm			X	
Torque wrench	Adjustable up to min. xx Nm				X
Depth micrometer	0 – 25 mm	X	X	X	X
Feeler gauge set	–	X	X	X	X
Retainer tool	Supplied with pump	X	X	X	X
Hook spanner	HN5	X			
Hook spanner	HN9/10		X		
Hook spanner	HN12/13			X	
Hook spanner	HN16/17				X
Soft-faced mallet		X	X	X	X
Steel hammer		X	X	X	X
Screwdriver		X	X	X	X
Ball bearing extractor		X	X	X	X

A selection of special tools is available, see chapter 5.0

4.2 General instructions



Assembly and disassembly may be performed by qualified personnel only. Always wear the appropriate safety clothing. Make sure that the personnel is properly instructed and educated.

Insufficient or wrong assembly and disassembly can lead to the pump malfunction. SPX is not liable for accidents and damage caused by non-compliance with the guidelines.

Always work in a clean surrounding. Keep all highly sensitive parts such as seals, bearings, etc. in their original packaging as long as possible.

Use a stainless steel work surface.

For maintenance and repair use only appropriate tools that are in good condition.



Check that the parts to be used have not been damaged during transport.



Never work on the pump in operation. In case of a disassembled pump, avoid any contact with the rotors when turning the shaft manually.

Do not forget that the pump can be started even when the pump cover has been removed for e.g. cleaning. Never run the pump without pump cover.

After disassembly carefully clean the parts and check them for damage, especially the mounting surfaces, and replace all damaged parts.

All parts fitted together at the disassembly must stay together when reinstalled, especially the rotors, shafts, bearings and shims.

4.3 O-rings and lip seals

When working with lip seals or O-rings, take care not to damage them as they pass over any sharp edges of splines, threads, etc. Be sure that the O-rings are not twisted in the groove when installing.

All O-rings and sealing lips should be lightly lubricated with a suitable lubricant before fitting, e.g. soap water.

Note! For food applications use H1 approved lubricant.

For O-rings made of PTFE, it is advised to heat them up in hot water before placement. A warmed up O-ring becomes more soft, thus easier to install.

4.4 Shutdown

Before starting the maintenance or inspection, follow the next steps to shut down the pump.

1. Stop the pump. To prevent the motor from starting while you are working on the pump follow the procedure below:
 - a) Turn off the pump at the electrical cabinet
 - b) Set the pump circuit breaker to off
 - c) Secure the circuit breaker from switching on with a lock. If not possible take the fuses with you to the working place. Sign the electrical cabinet "out of work"
 - d) Remove, if necessary, the protection around the mechanical coupling only when the pump has come to a complete standstill.
2. Let the pump cool down to the ambient temperature, if suitable for the liquid being pumped.
3. Isolate and depressurise flushed product auxiliary services.
4. Close both suction and discharge valves.
5. Drain and purge the pump head and pipe work.
6. Clean the pump externally before disassembly.

4.5 Tightening torque [Nm] for nuts and screws

Pos.	Description	TW1 Dimension	Torque [Nm]	TW2 Dimension	Torque [Nm]
0250	Retainer	M10 (X-3CrNiMoN27.5.2)	22	M16 (X-3CrNiMoN27.5.2)	69
0450	Cap nut	M8-DIN917-(A4)	21	M10-DIN917-(A4)	41
0455	Cap nut	M6-DIN917-(A4)	8.5	M8-DIN917-(A4)	21
0510	Screw	M5x12-DIN912-(8.8)	5	M6x12-DIN912-(8.8)	8.5
0520	Screw	M5x20-DIN912-(12.9)	8.5	M6x18-DIN912-(12.9)	9
0525	Screw	M6x12-DIN912-(A4)	8.5	M8x20-DIN933-(A4)	21
0620	Locking nut (*)	M25X1.5 SKF KM5	(*)	M45X1.5 SKF KMT9	(*)

Pos.	Description	TW3 Dimension	Torque [Nm]	TW4 Dimension	Torque [Nm]
0250	Retainer	M16 (X-3CrNiMoN27.5.2)	88	M20 (X-3CrNiMoN27.5.2)	179
0450	Cap nut	M16-DIN917-(A4)	172	M20-DIN917-(A4)	250
0455	Cap nut	M10-DIN917-(A4)	41	M12-DIN917-(A4)	71
0510	Screw	M8x20-DIN912-(8.8)	21	M10x25-DIN912-(8.8)	41
0520	Screw	M8x22-DIN912-(12.9)	22	M10x25-DIN912-(12.9)	42
0525	Screw	M10x20-DIN933-(A4)	41	M12x25-DIN933-(A4)	71
0620	Locking nut (*)	M55X2 SKF KMT11	(*)	M80X2 SKF KMT16	(*)

(*) Locking nut Pos. 0620:

Tighten nut until friction torque measured on shaft = specified torque

See sectionn 4.7.3.

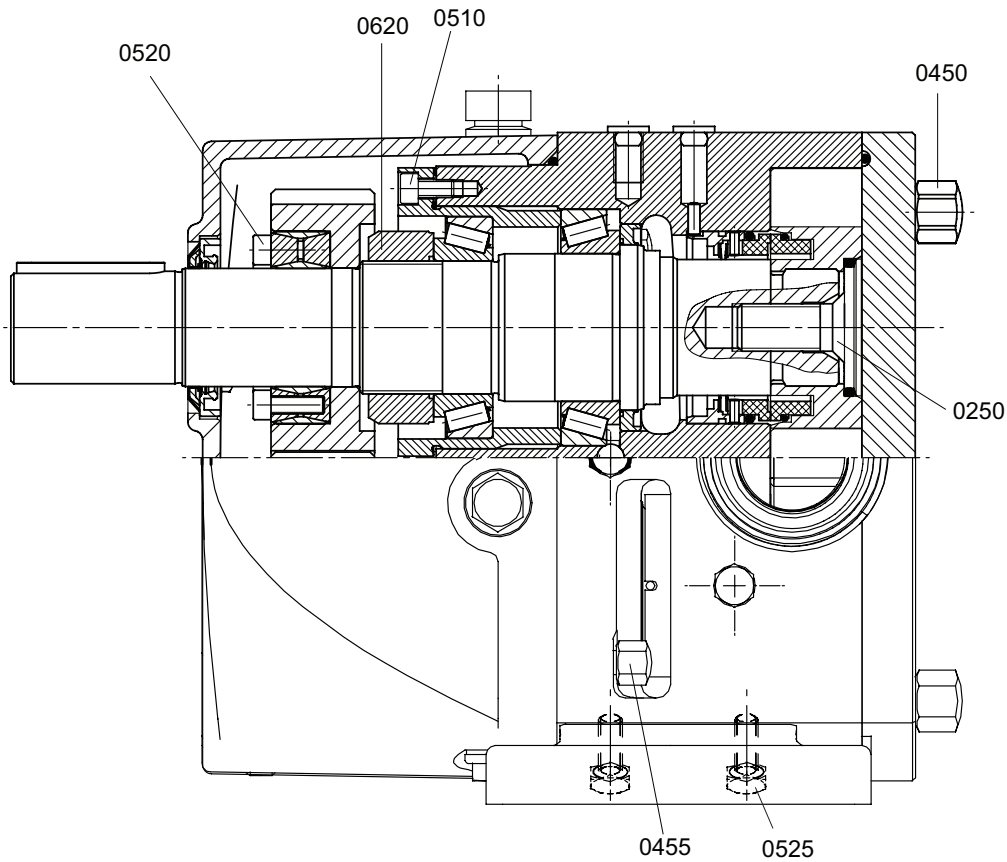

4.6 Disassembly

See also sections 4.2 General instructions, 4.3 O-rings and lip seals, 4.4 Shut down and 4.5 Tightening torque for nuts and screws.

4.6.1 Pump cover and rotor removal

Do not forget that liquid may still flow out of the rotor case when removing the pump cover (0030).

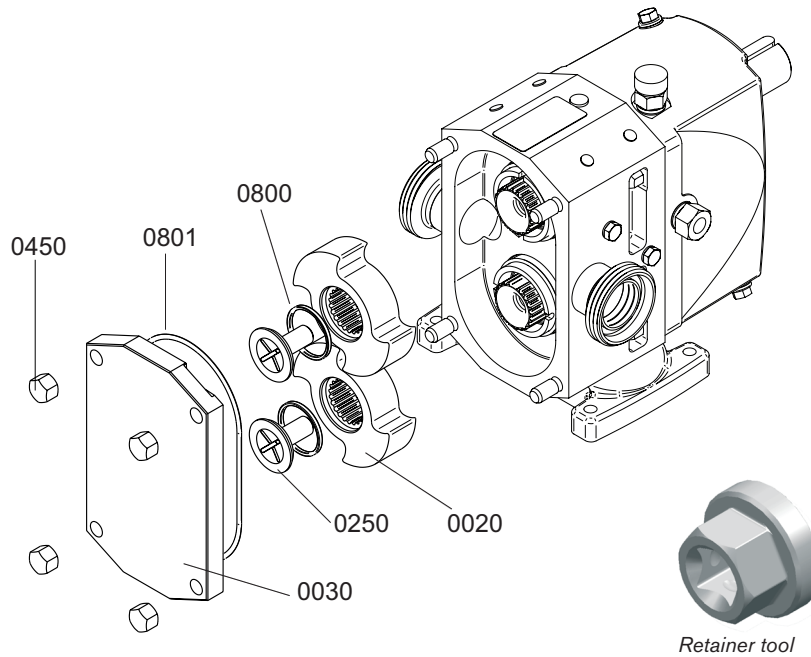

1. Remove the cap nuts (0450).
2. Cavities are provided diagonal on the mounting surface between cover and rotor case to permit removing pump cover with aid of e.g. a screwdriver. Check the O-ring (0801).
3. Lock the rotors by placing a block of soft material between the rotors.
4. Unscrew retainer (0250) counter clockwise by using the retainer tool.
5. Remove retainer O-ring (0800).
6. Remove the rotor (0020).
7. Remove the second rotor in the same way.

4.6.2 Disassembly of seals

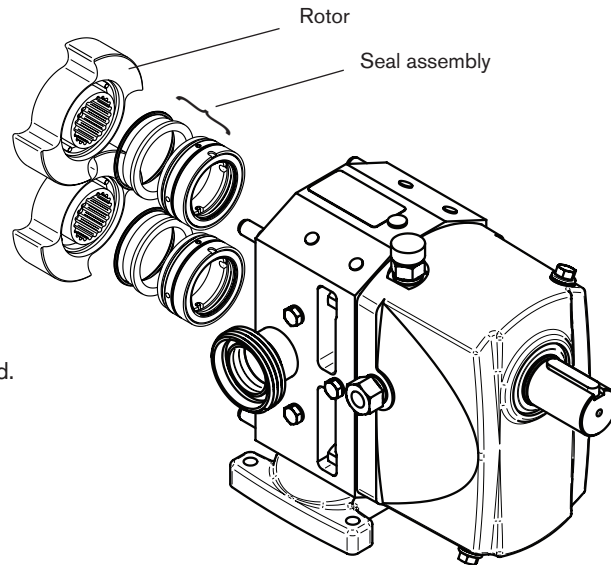

Only if section 4.6.1 has been completed.

4.6.2.1 Single mechanical seal

1. Remove the rotating seal face and O-ring (0082) from the rotor.
2. Remove the stationary seal face together with O-ring (0083) from the rotor case.
3. Remove the stationary part of the seal together with the spring from the rotor case.
4. Check O-rings (0082) and (0083).
5. Check condition of seal faces and spring.

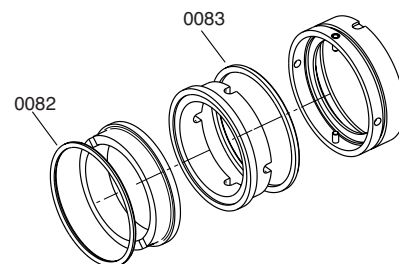
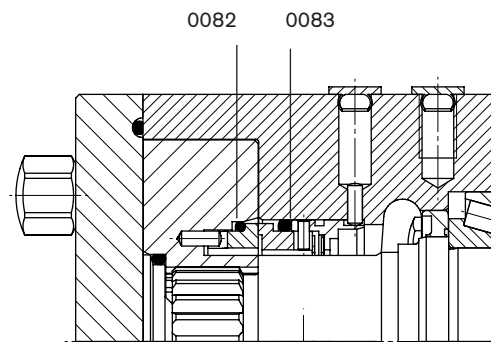

4.6.2.2 Single mechanical seal with flushing

1. Remove the rotating seal face and O-ring (0082) from the rotor.
2. Remove the stationary seal face together with the O-ring (0083) from the rotor case.
3. Remove the stationary part of the seal together with the O-ring (0085), spring and lip seal (0890) from the rotor case.
4. Remove lip seal (0890) from the stationary part of the seal.
5. Check the conditions of O-rings, lip seal, seal faces and spring.

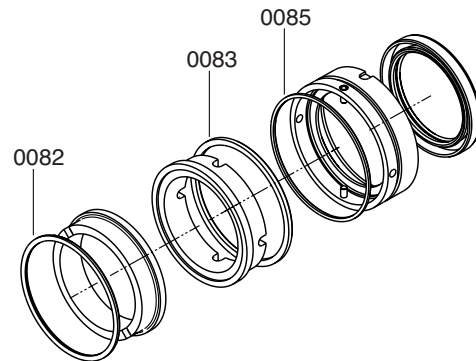
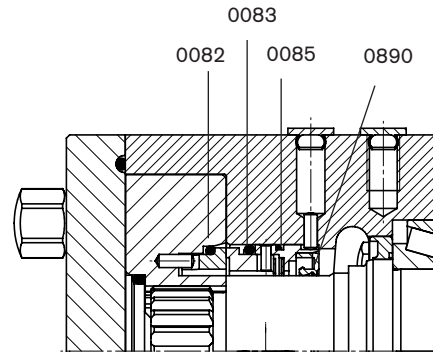

4.6.2.3 Double mechanical seal

1. Remove the rotating seal face and the O-ring (0082) from the rotor.
2. Remove the product side - stationary seal face together with the O-ring (0083) from the rotor case.
3. Remove the stationary part of the seal together with O-ring (0085) and spring from the rotor case.
4. Remove the atmospheric side - stationary seal face with O-ring (0086) together with the rotating seal face and O-ring (0087) from the shaft.

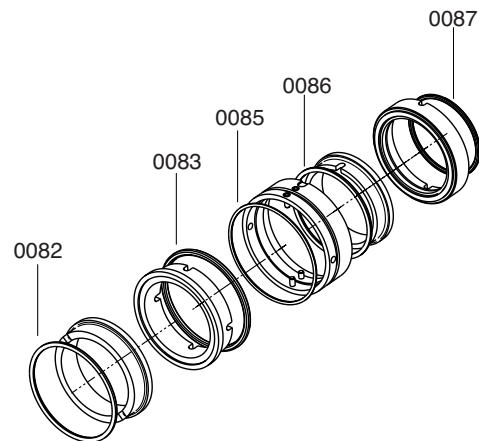
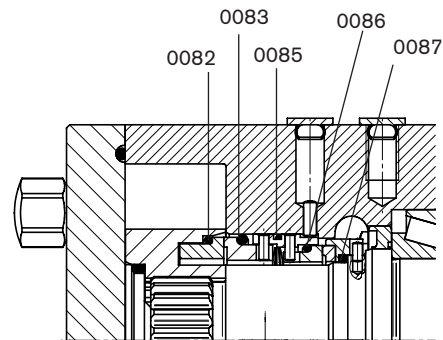

4.6.2.4 Single O-ring seal

1. Remove the shaft sleeve (0130) from the shaft and O-ring (0082) from the rotor.
2. Remove the support ring (0097) together with O-ring (0085) and O-ring (0183) from the rotor case. The support ring can be pushed out from the backside via the access opening in the rotor case (TW2-4).

On TW 1, please use special tool, see section 5.7.

3. Remove the O-rings (0183) and (0085) from the support ring (0097).

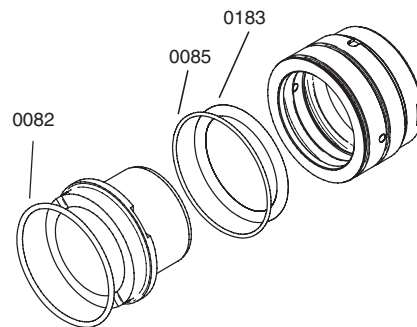
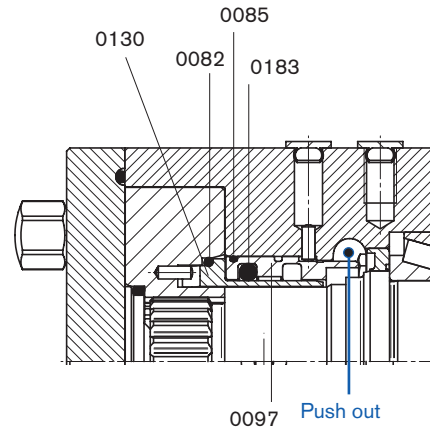

4.6.2.5 Double O-ring seal

1. Remove the shaft sleeve (0130) from the shaft and O-ring (0082) from the rotor.
2. Remove the support ring (0097) together with O-rings (0085) and (0183) from the rotor case. The support ring can be pushed out from the backside via the access opening in the rotor case (TW2-4).

On TW 1, please use special tool, see section 5.7.

3. Remove the O-rings (0183) and (0085) from the support ring (0097).

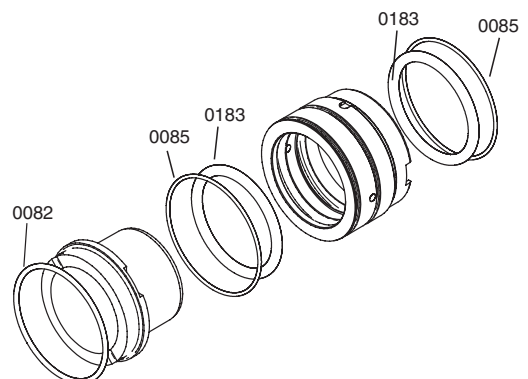
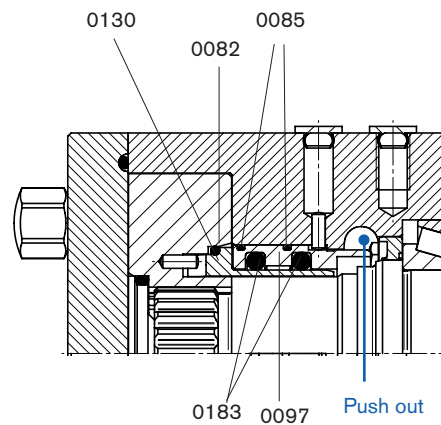

4.6.3 Disassembly of drive assembly

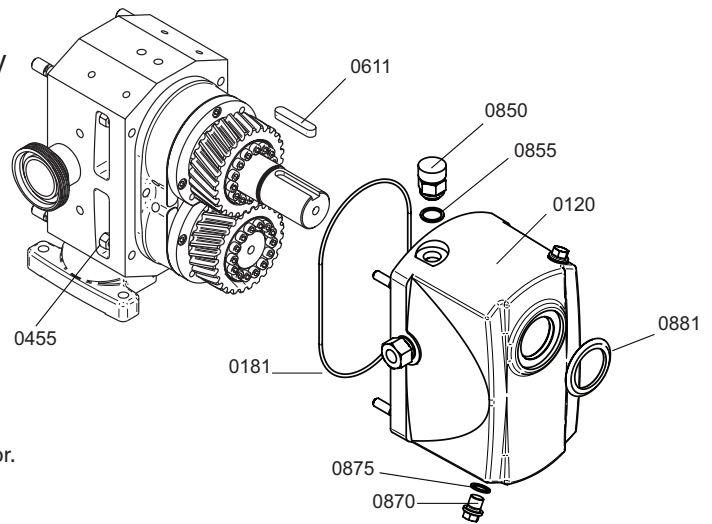

1. Disconnect the pump from the motor.
2. Remove key (0611).
3. Remove the air breather (0850) with sealing ring (0855) and plug (0870) with sealing ring (0875). Drain the oil in an appropriate reservoir.
4. Unscrew the cap nuts (0455) in the access opening between hydraulic part and bearings.
5. Remove the end cover (0120) with V-seal (0881) to the back.
6. Remove O-ring (0181) from the rotor case.

7. **TW1**
Loosen the screws (0520) cross-wise in several steps to release the locking elements (0651) from the gear.

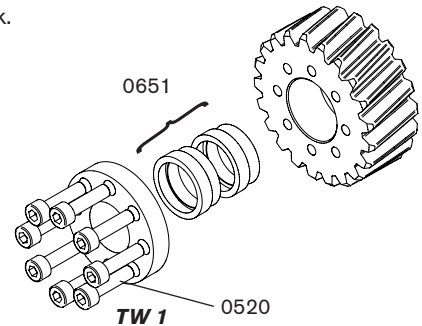

7. **TW2, TW3, TW4**
Loosen the screws of the locking assembly (0652) crosswise in several steps to release it from the gear. The locking assembly is self-releasing.

8. Remove the gear (0190) together with the locking assembly (0652) from the shaft. (For TW1 locking elements (0651)).

9. Do this on both shafts.

10. Remove the screws (0510) from the bearing holder (0121).

11. Screw 2 bolts in the 2 threaded holes in the flanges of the bearing holder.

12. Tighten the bolts crosswise to pull the bearing holder (0121) together with the shaft and both bearings out of the rotor case.

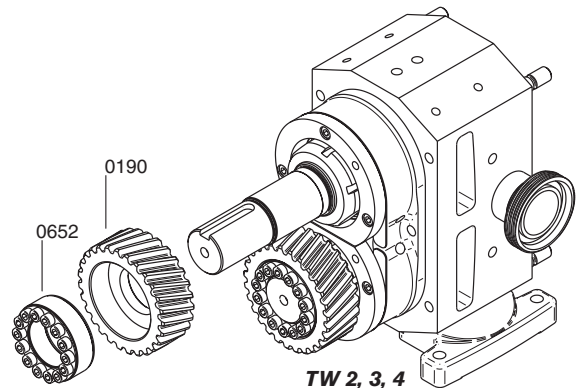

13. Remove the shim (0171).

14. Do this on both shafts.

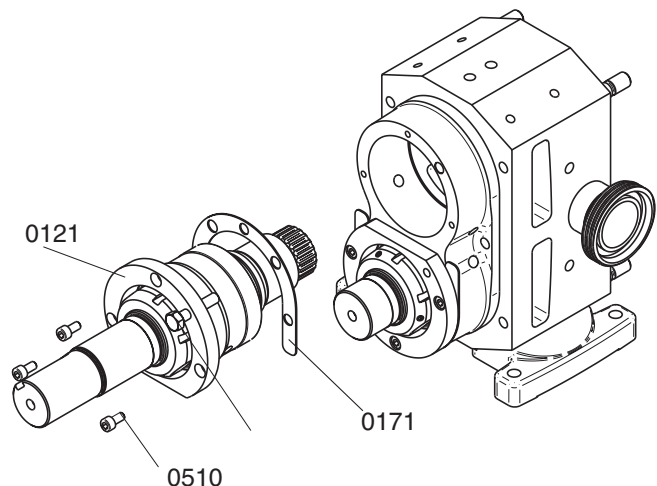

4.6.4 Disassembly of shaft arrangement

1. **TW1**

Bend the tooth of the locking washer (0630) straight out of the groove of the nut and remove the locking nut (0620).

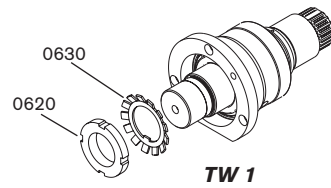

1. **TW2, TW3, TW4**

Loosen set screws of locking nut (0620) and remove it.

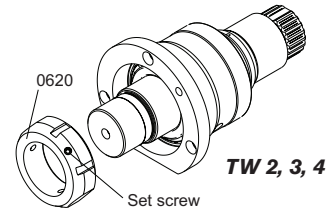

2. Support the bearing holder on mounting surface and press the internal ring of bearing (0701) together with the shaft and bearing (0700) out of the bearing holder.

Ensure that the mounting surface of the bearing holder is not damaged.

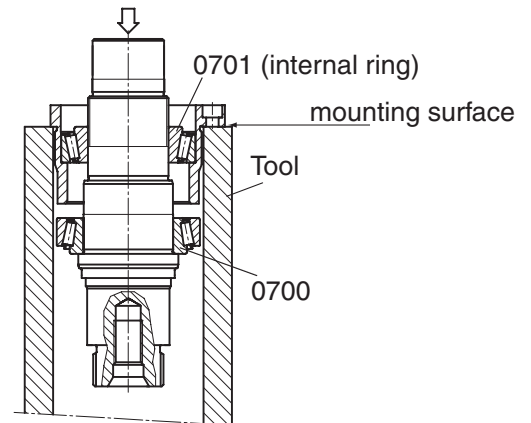

3. Remove the bearing holder with external part of bearing (0701) and the external ring of bearing (0700) from the shaft.

4. Remove the external ring of bearing (0701) from the bearing holder (0121).

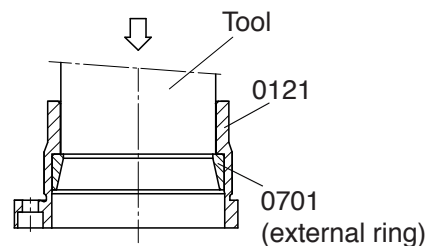

5. Remove the internal ring of bearing (0700) with rollers from the shaft.

6. Do the same for the second shaft.

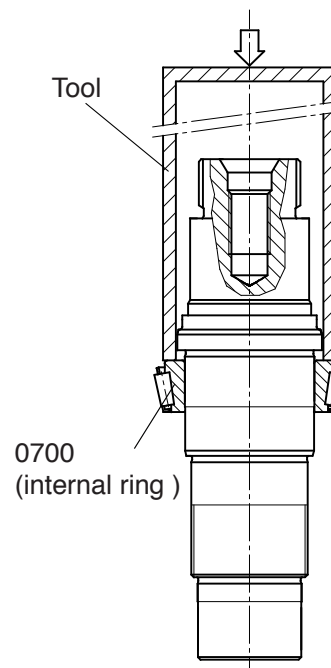

4.6.5 Disassembly of rotor case

1. Remove lip seals (0885) from rotor case.
2. If the feet have to be removed, loosen screws (0525) and remove feet.

4.7 Assembly

See also sections 4.2 General instructions, 4.3 O-rings and lip seals and 4.5 Tightening torque for nuts and screws.

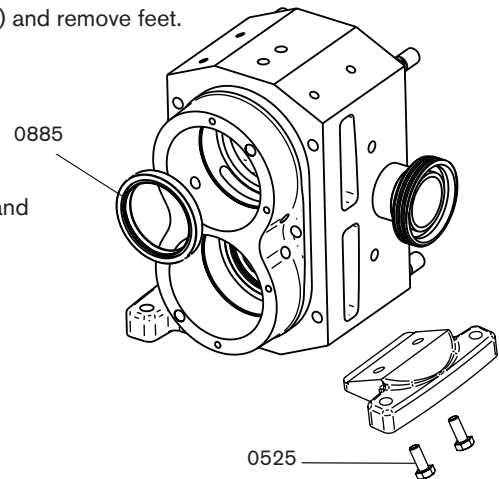

4.7.1 Pre-assembly of the rotor case

4.7.1.1 Foot assembly

1. Place the left foot on the rotor case and tighten with screws (0525). The small surface of the foot must be in contact with the bottom surface of the rotor case.

Make sure that the surfaces are clean.
2. Place the right foot on the rotor case and tighten with screws (0525).

4.7.1.2 Assembly of lip seals

1. Fill the space between the lips with grease.
2. Fit the lip seals (0885) into the rotor case. The spring must point in the direction of the bearing. The lip seals must be aligned with the axial surface inside the rotor case.

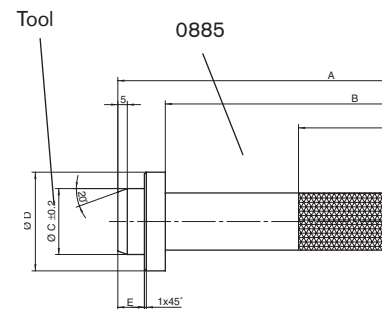

Tool : assembly tool for lip seal rotor case front end (see chapter 5.0)

4.7.2 Pre-assembly of shaft/bearing arrangement

1. Heat the internal ring of bearing (0700) up to 120°C.
2. Place the bearing on the shaft. Ensure that the axial surface of the internal ring of the bearing is pushed properly against the shaft shoulder.

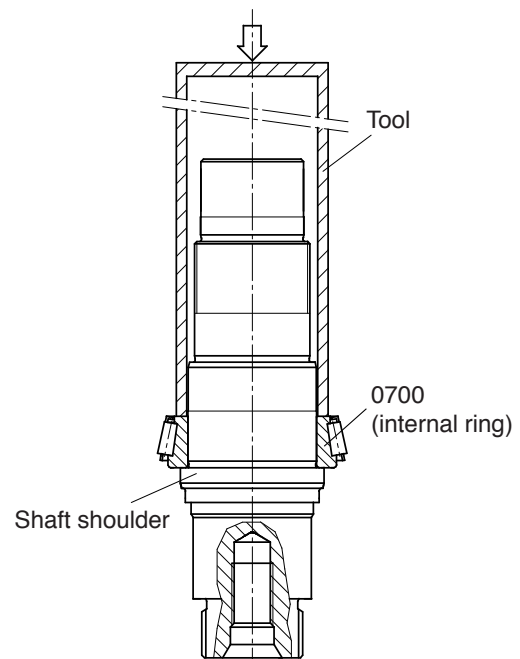

- Fit the external ring of bearing (0701) in the bearing holder (0121). Ensure that the axial surface of the bearing ring is pushed properly against the mounting surface inside the bearing holder.

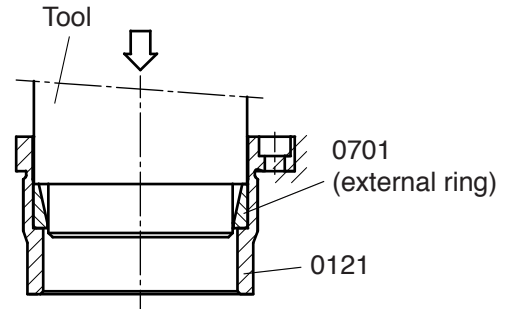

- Place the shaft vertical on the workbench and place the external ring of bearing (0700) and the bearing holder on the internal ring of bearing (0700).

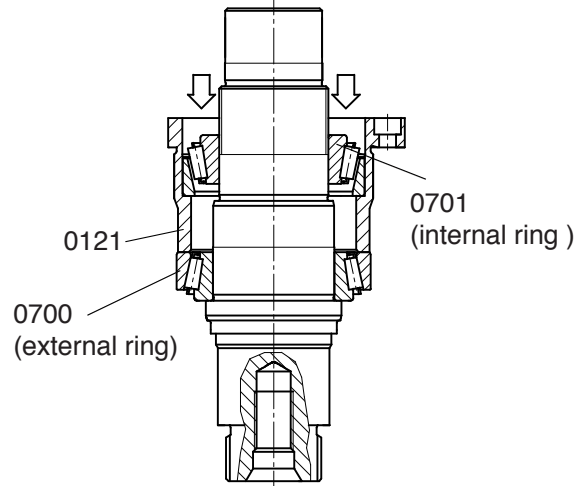

- Heat the internal ring of bearing (0701) up to 120°C and fit the bearing on the shaft.

Wait until the parts are cooled down to ambient temperature.

6. TW1

Place the locking washer (0630) on the shaft and screw on locking nut (0620) by hand until it makes contact with the internal ring of bearing (0701).

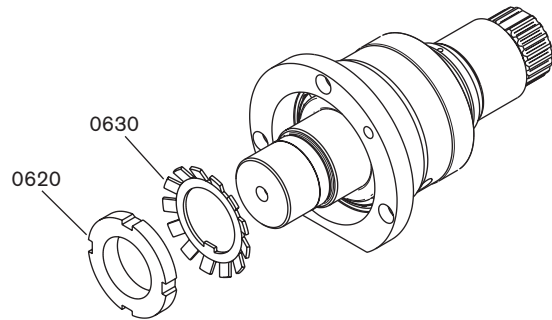

6. TW2, TW3, TW4

Screw on locking nut (0620) by hand until it makes contact with the internal ring of bearing (0701).

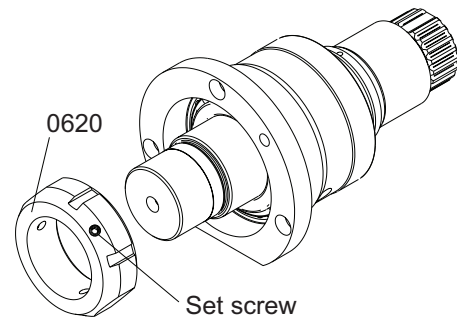

Pump	Torque
TW2-4	18 Nm

4.7.3 Assembly of shafts in the rotor case and setting of the tapered roller bearings

1. Fit both pre-assembled shafts with bearings in the rotor case and fix them with screws (0510).

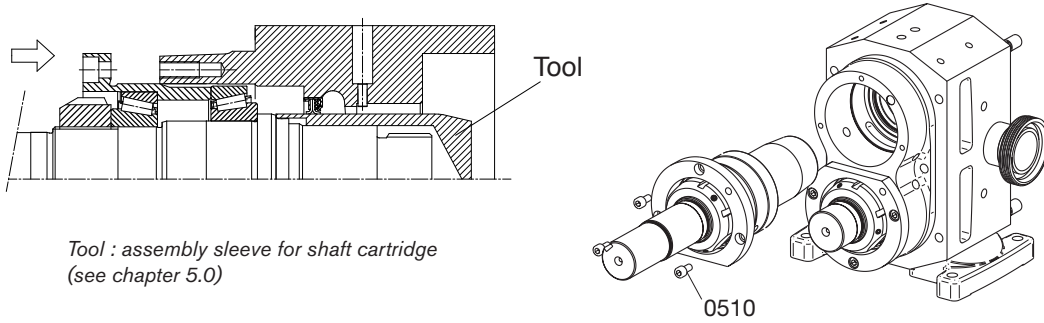

*Tool : assembly sleeve for shaft cartridge
(see chapter 5.0)*

2. Screw hexagon bolts in the threaded holes (retainer holes) in the front faces of the shaft.

TW1	M10x20
TW2	M16x30
TW3	M16x30
TW4	M20x50

3. To check the friction torque and adjust the bearing setting of each shaft separately do as follows:
 - Use the torque meter wrench (see picture) on the hexagon bolt to turn the shaft and measure the friction torque



Torque meter wrench only

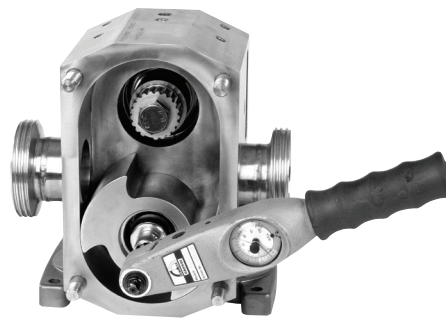

Measuring friction torque

Pump	Torque
TW1	1.6 – 1.8 Nm
TW2	3.2 – 3.4 Nm
TW3	4.5 – 4.7 Nm
TW4	7.0 – 7.3 Nm

- Remove the torque meter wrench
- Place one rotor on the shaft

- Place a block of soft material (plastic or wood) between rotor and rotor case to block the rotor against rotation
- Turn locking nut (0620) in order to adjust the pre-load of the bearings according to the measured friction torque

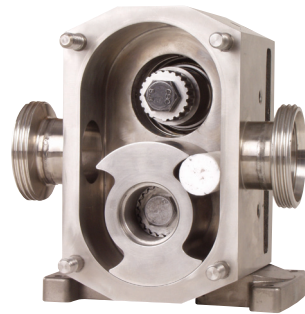

Rotor locked with plastic block

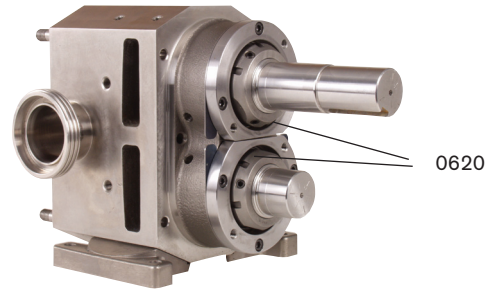

Locking nut of the pre-loading

- Remove the block of material

Repeat the steps (in point 3) until the correct friction torque setting is reached.

4. After that secure the locking nut

TW 1: by bending one tooth of the locking washer into a groove of the locking nut

TW2, TW3, TW4: by tightening the set screws in the locking nut (torque 18 Nm).

5. Adjust the bearings of the second shaft in the same way and remove hexagon bolts from the shafts.

4.7.4 Axial adjustment of the rotors

To adjust the position of the rotors on both shafts separately do as follows:

1. Fit the rotor on the shaft.
2. Place the O-ring on the retainer and assemble it to the shaft.
3. Tighten the retainer with specified torque to fix the rotor on the shaft (see section 4.5 Tightening torque for nuts and screws).
4. Measure the distance X from the front surface of the rotor to the front surface of the rotor case.

Determine the required thickness of the shim [mm] by using the following formula:

- Min. thickness of shim = measured distance X + min. axial clearance A
- Max. thickness of shim = measured distance X + max. axial clearance A

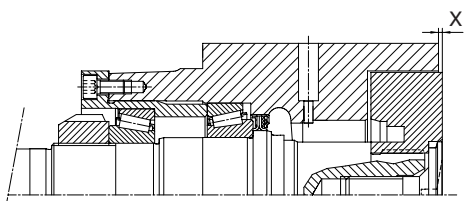

For clearances see chapter 3.0.

5. Adjust the thickness of the shim by peeling of the required number of layers of 0.025 mm (coloured).
6. Remove the retainers from both shafts and take off the rotors.
7. Remove screws (0510).
8. Screw 2 bolts in the flange of the bearing holder and push the bearing holder approx. 2 mm backwards out of the rotor case.
9. Remove the 2 bolts.
10. Place the shim between the flange of the bearing holder and the rotor case.
11. Tighten the bearing holder with screw (0510).
12. Place the rotors on the shafts, tighten them with the retainers in the same way as mentioned above and check all axial clearances between rotor and pump cover.

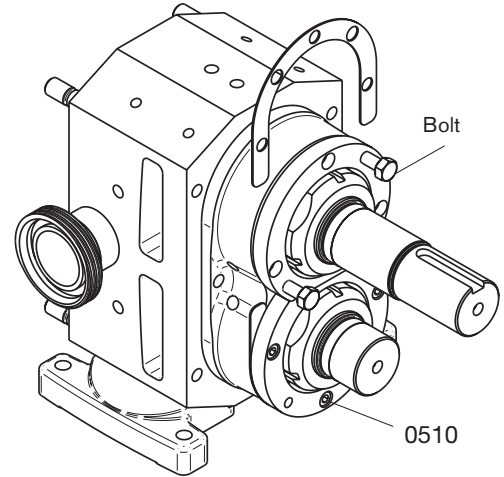

4.7.5 Assembly of gears

1. Place the gear (0190) with locking assembly (0652) (locking elements (0651) for TW1) on the lay shaft (0051).

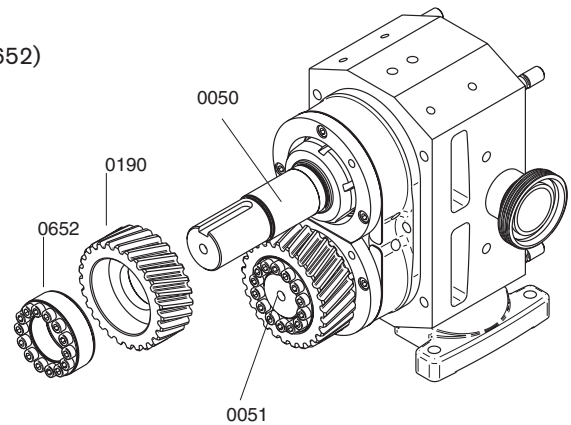

2. **TW1**
Check if the screws of the locking elements are clean, lubricate them with clean oil and fit them in place.

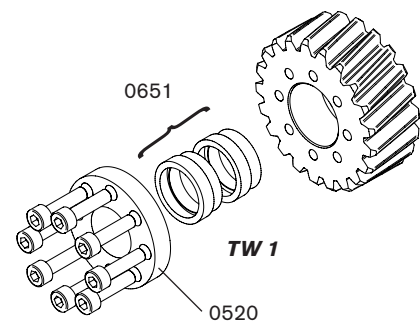

3. Place the gear (0190) with locking assembly (0652) (locking elements (0651) for TW1) on the drive shaft (0050).

Use the torque wrench to tighten the bolts on the lay shaft with the specified torque following the tightening sequence shown below.

4. Check proper running of the gears ("no heavy points") by measuring axial run out of the gears (max 0.05 mm).
5. If the gears cannot be turned smoothly re-adjust the gears.

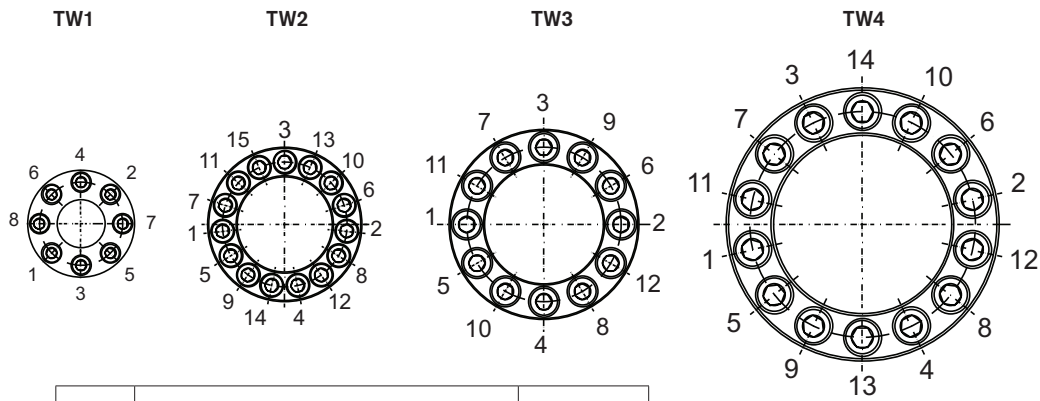

Pump	Description	Torque [Nm]
TW1	Allen screw DIN 912 M5x20 (12.9)	8.5
TW2	Allen screw DIN 912 M6x18 (12.9)	9
TW3	Allen screw DIN 912 M8x22 (12.9)	22
TW4	Allen screw DIN 912 M10x25 (12.9)	42

4.7.6 Synchronization of the rotors

4.7.6.1 Manual synchronization

1. Position the rotors by turning the drive shaft manually to the position shown in the diagram. Check the clearance between the rotors with a gauge blade in all rotor positions. Dimension X should be the same in all positions.

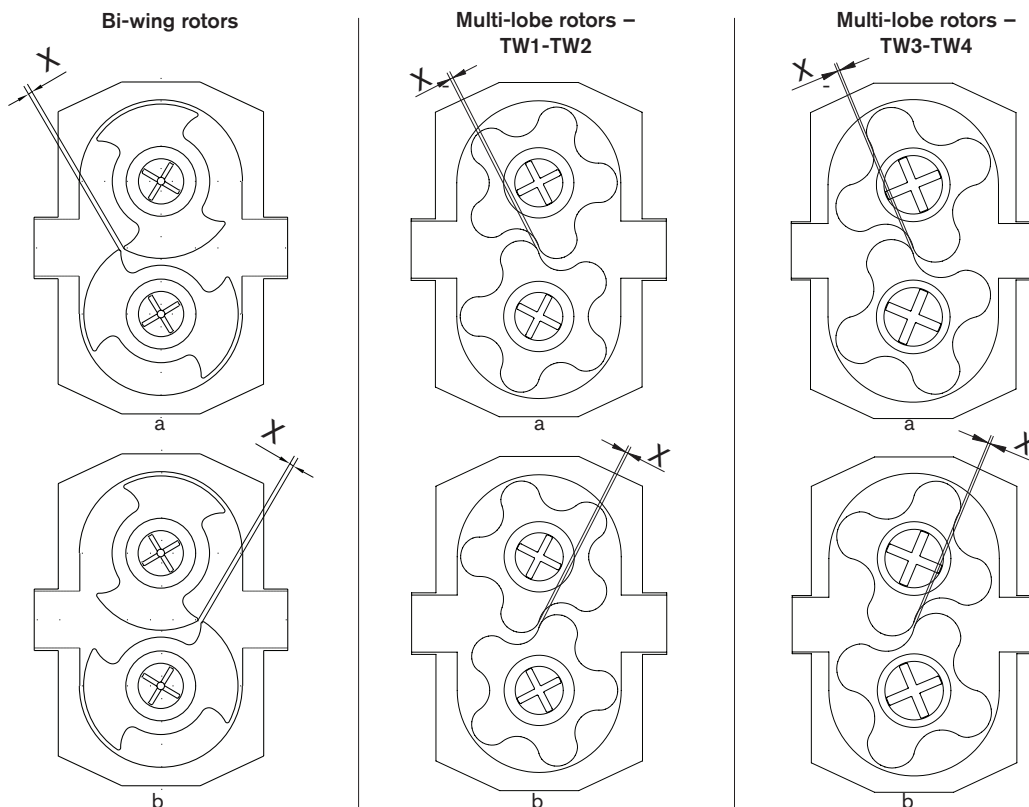

2. Place a block of soft material between the rotors to lock them against each other.
3. Tighten now the screws of the locking assembly/elements in the same way as described for the lay shaft.
4. Check the clearance X between the rotors (pos a), turn the drive shaft to the pos b shown in the lower pictures and check the clearance in this position also. In both positions dimension X should be the same.
5. Remove the retainers and rotors.

4.7.6.2 Synchronization with special tools

Please note these tools are to be used only for the standard Bi-wing rotors.

For multi-lobe rotors see 4.7.6.1 Manual synchronization.

1. Position the shafts using the synchronization tool.
2. Assemble the synchronization tool as indicated on the figure, so that the shafts are well positioned.
3. Tighten the screws of the locking assembly/elements in the same way as described for the lay shaft.

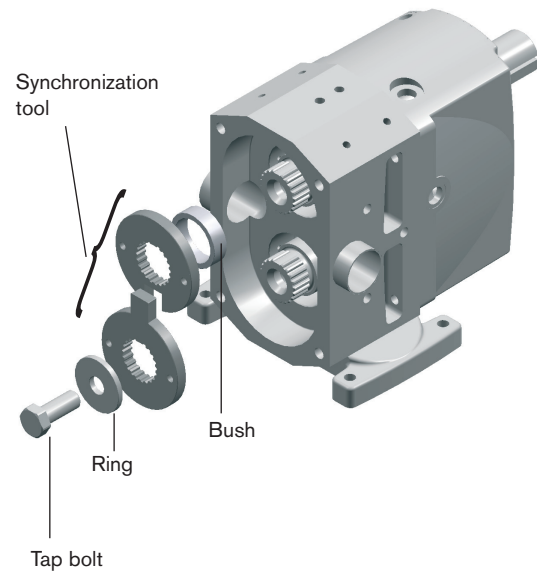

4.7.7 Assembly of end cover

1. Fit lip seal (0880) with Loctite 243 in end cover (0120) and place O-ring (0181) on the rotor case.

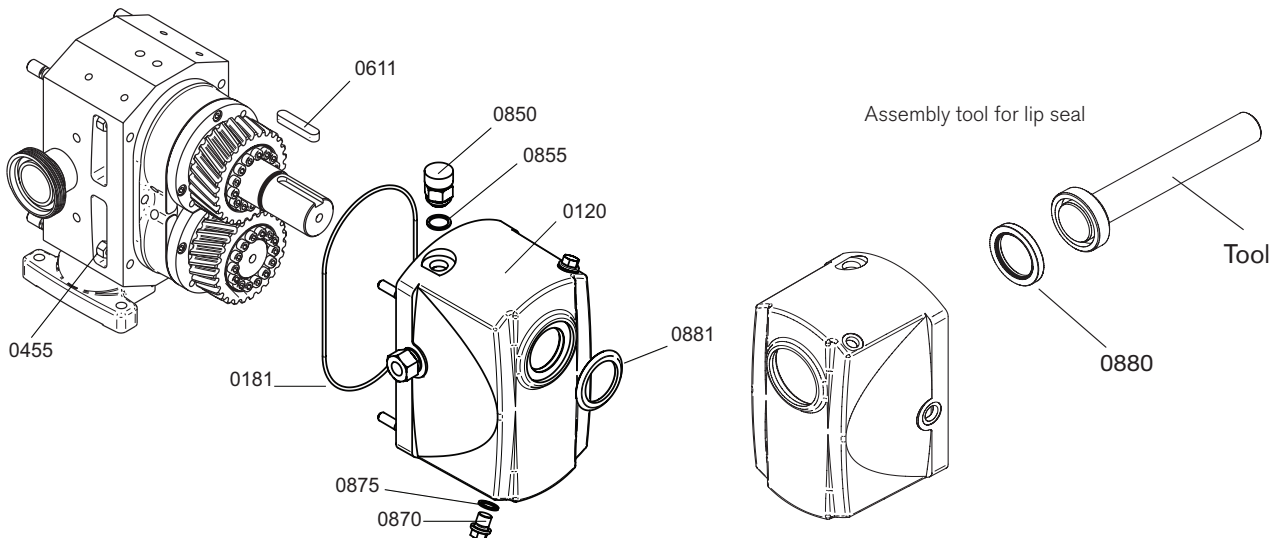

2. Put the end cover into position and tighten it with cap nuts (0455).
3. Fill the space between the lips of the V-seal (0881) with grease.
4. Fit the V-seal on the shaft by using the tool, for the right position; see table below.

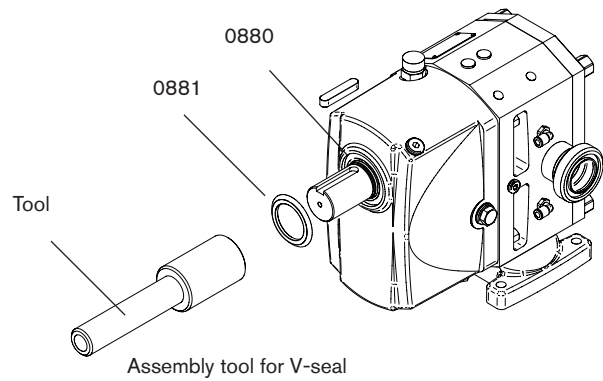
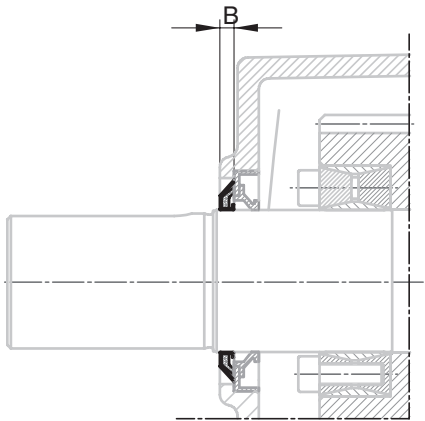

Shaft position

	B
TW1	4
TW2	4.5
TW3	5.5
TW4	5.5

Dimensions in mm

4.7.8 Assembly of seals

4.7.8.1 Single mechanical seal

1. Place the stationary part of the seal in the rotor case.

Ensure that the pin in the rotor case fits into the groove in the stationary part of the seal.

2. Put O-ring (0083) on the stationary seal face. Place the stationary seal face with O-ring into the rotor case.

Ensure that the pins in the stationary part of the seal are fitting into the grooves in the stationary seal face.

3. Put O-ring (0082) on rotating seal face. Place the rotating seal face with O-ring into the rotor.

Ensure that the pins in the rotor are fitting into the grooves of the rotating seal face.

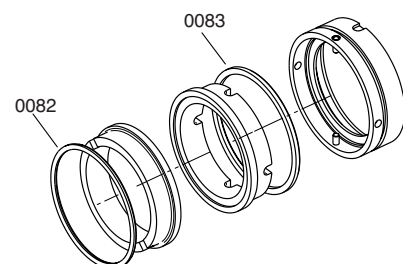
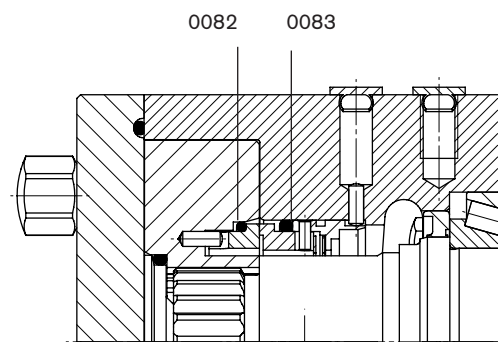
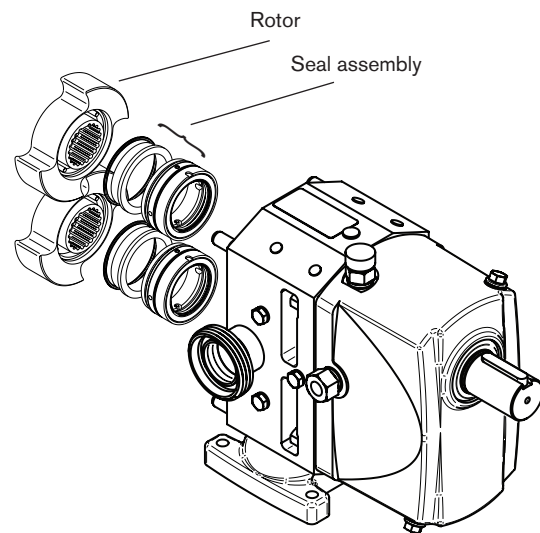

4.7.8.2 Single mechanical seal with flushing

1. Fit lip seal (0890) and O-ring (0085) in the stationary part of the seal.
2. Place the stationary part of the seal, O-ring and spring in the rotor case.

Ensure that the pin in the rotor case fits into the groove in the stationary part of the seal.

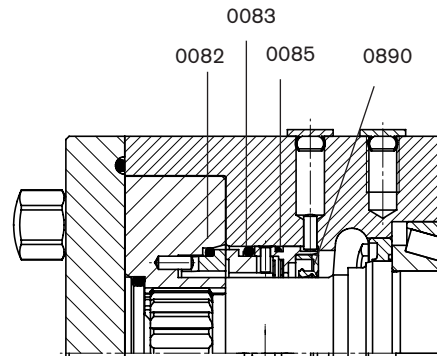

3. Put O-ring (0083) on the stationary seal face. Place the stationary seal face with O-ring into the rotor case.

Ensure that the pins in the stationary part of the seal are fitting into the grooves in the stationary seal face.

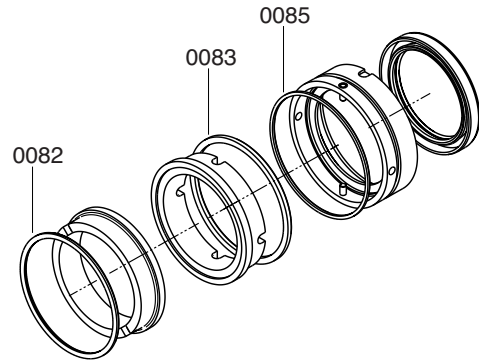

4. Put O-ring (0082) on rotating seal face. Place the rotating seal face with O-ring into the rotor.

Ensure that the pins in the rotor are fitting into the grooves of the rotating seal face.

4.7.8.3 Double mechanical seal

1. Place O-ring (0087) on the atmospheric side - seal face. Push the atmospheric side - rotating seal face with O-ring over the shaft.

Ensure that the pins in the shaft are fitting into the grooves in the seal face.

2. Place O-ring (0085), O-ring (0086) and atmospheric side - stationary seal face into the stationary part of the seal. Place the stationary part of the seal with O-rings and atmospheric side seal face into the rotor case.

3. Put O-ring (0083) on the product side - stationary seal face. Place the stationary seal face with O-ring into the rotor case.

Ensure that the pins in the stationary part of the seal are fitting into the grooves in the stationary seal face.

4. Put O-ring (0082) on rotating seal face. Place the rotating seal face with O-ring into the rotor.

Ensure that the pins in the rotor are fitting into the grooves of the rotating seal face.

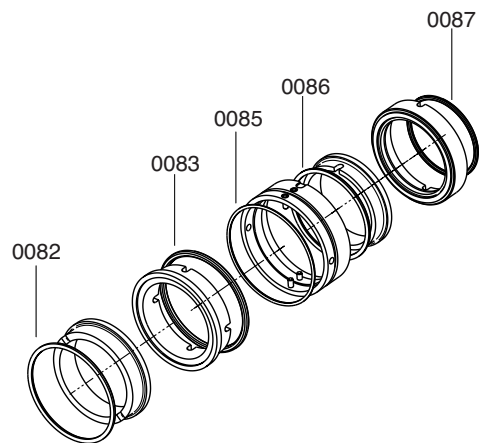
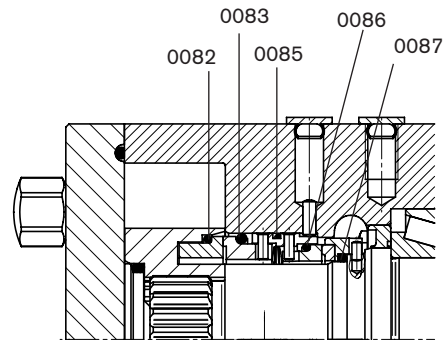

4.7.8.4 Single O-ring seal

1. Fit O-rings (0085) and (0183) in support ring (0097). Place support ring with O-rings into the rotor case.

Ensure that the pin in the rotor case fits into the groove in the support ring.

2. Place O-ring (0082) on the shaft sleeve (0130). Place shaft sleeve with O-ring into the rotor.

Ensure that the pins in the rotor are fitting into the grooves of the shaft sleeve.

3. Rotor and shaft sleeve should be assembled together.

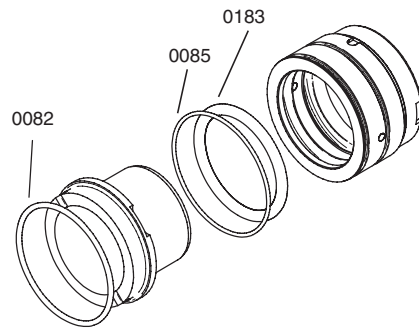
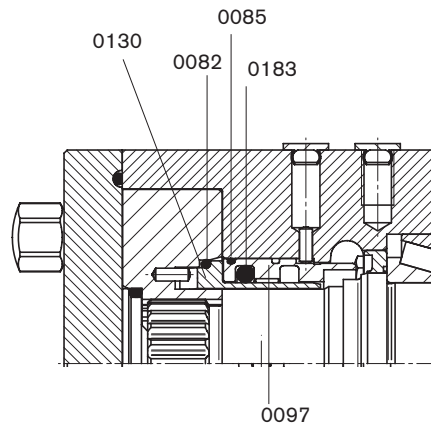

4.7.8.5 Double O-ring seal

1. Fit O-rings (0085) and (0183) in support ring (0097). Place support ring with O-rings into the rotor case.

Ensure that the pin in the rotor case fits into the groove in the support ring.

2. Place O-ring (0082) on the shaft sleeve (0130). Place shaft sleeve with O-ring into the rotor.

Ensure that the pins in the rotor are fitting into the grooves of the shaft sleeve.

3. Rotor and shaft sleeve should be assembled together.

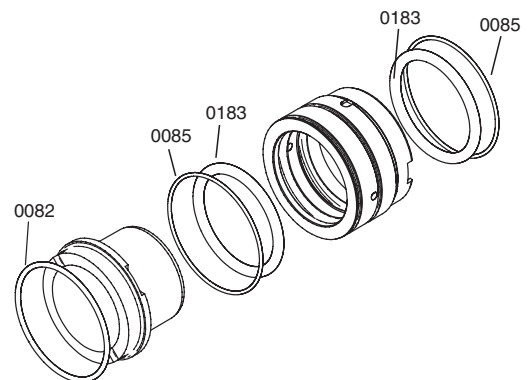
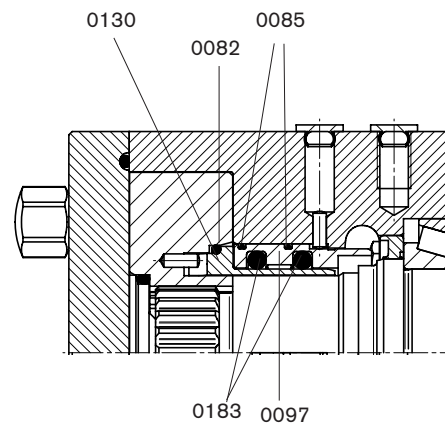

4.7.9 Assembly of rotors and pump cover

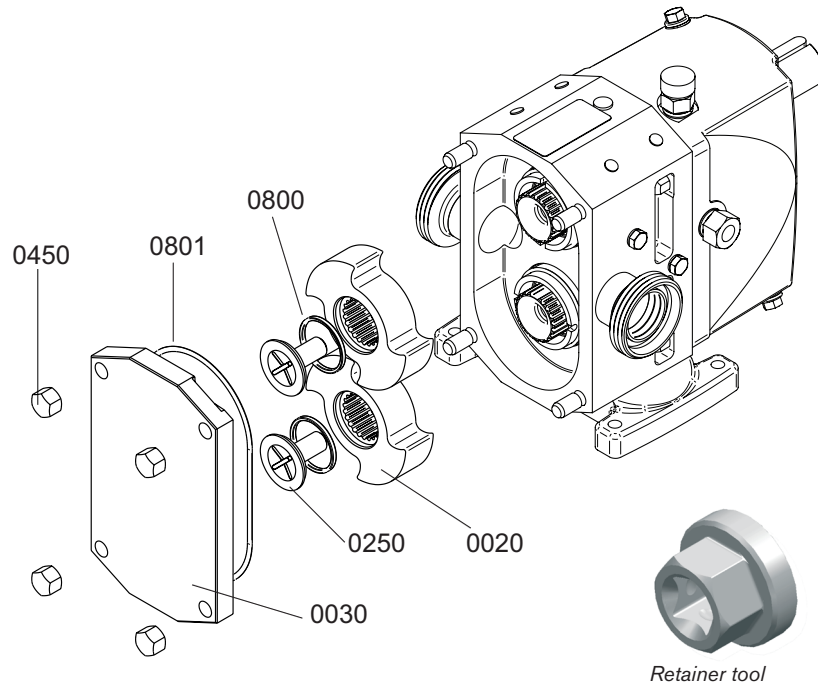

4.7.9.1 Assembly of rotors

1. Place the rotors (0020) on the shafts.
2. Place O-rings (0800) on the retainers (0250) and fasten the retainers. See chapter 4.5 Tightening torque for nuts and screws.
3. Block the rotors against each other by putting a block of soft material between the rotors.
4. Tighten the retainers clockwise with the specified torque, using the retainer tool. See chapter 4.5 Tightening torque for nuts and screws.
5. Check all clearances.

4.7.9.2 Assembly of pump cover

1. Put the O-ring (0801) into the groove in the pump cover.
2. Place the pump cover on the rotor case. Be sure that O-ring (0801) stays in the groove and is not squeezed between pump cover and rotor case.
3. Secure the pump cover with cap nuts (0450).

5.0 Special tools

5.1 General

There are a number of special tools available to facilitate assembling the pumps. By using these tools the risk of damaging sealing elements is reduced and the time needed for maintenance and/or repair will be shorter.

These tools can be ordered from SPX or produced in the own workshop. The article numbers for ordering are indicated in the tables under each drawing/picture together with the dimensions of the tool in question (if applicable).

5.2 Assembly tool for lip seals

Place: Rotor case front end

Purpose: For fitting the lip seal (0885) into the rotor case (see section 4.7.1.2)

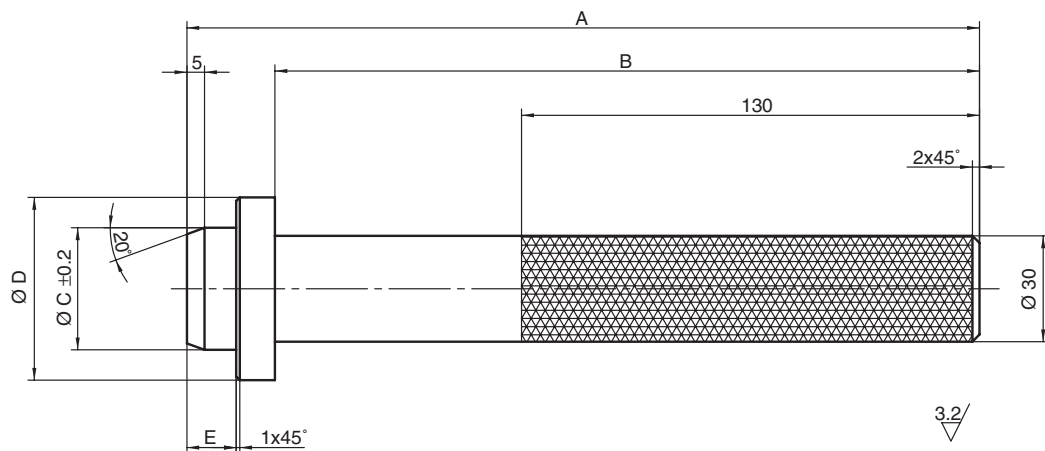

Pump type	Article number	A	B	ØC ±0.2	ØD +0.1 0	E
TW1	3.94935.11	225	200	34.6	51.8	14
TW2	3.94936.11	235	200	55.6	79.8	17
TW3	3.94937.11	235	200	68	109.8	17
TW4	3.94938.11	290	250	99.6	149.8	20

All dimensions in mm

5.3 Assembly sleeve for shaft cartridge

Place: Rotor case front end

Purpose: For fitting the shaft/bearing assembly into the rotor case (see section 4.7.3)

Assembly sleeve TW1

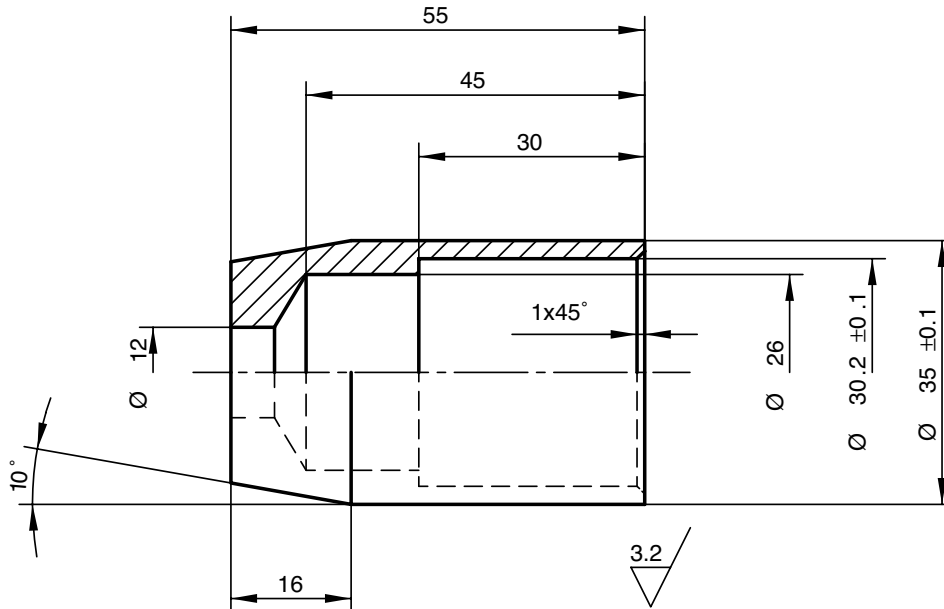

Assembly sleeve TW2, TW3 and TW4

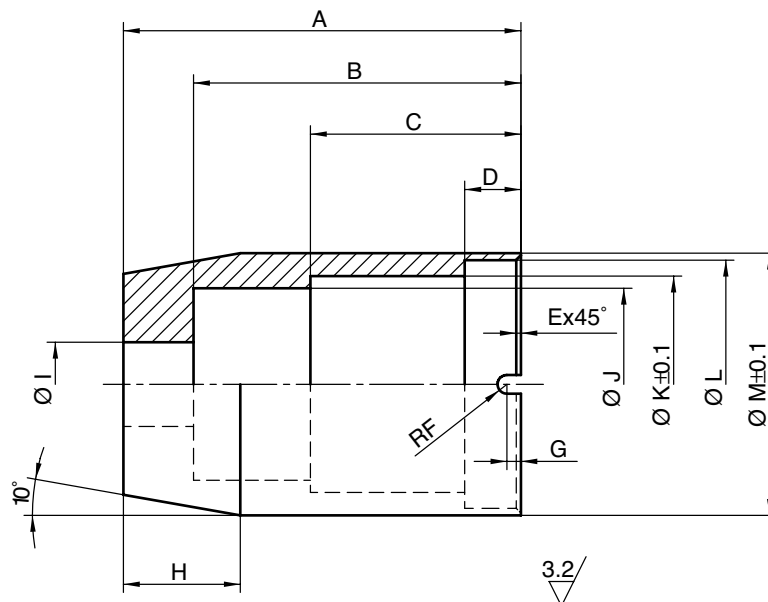

Pump type	Article number	A	B	C	D	E	F	G	H	Ø I	Ø J ±0.1	Ø K	Ø L ±0.1	Ø M
TW1	3.94939.11													
TW2	3.94940.11	85	70	45	12	1	2	2	25	18	41	46.2	53	56
TW3	3.94941.11	90	80	45	14	0.5	2	2	25	18	56	60.2	68 +0.2 -0.2	71.2
TW4	3.94942.11	125	108	55	15	1	2.5	2.5	30	22	75	85.2	91	100

All dimensions in mm

5.4 Assembly tool for lip seal

Place: Endcover rear end

Purpose: For fitting the radial lip seal (0880) into the end cover (see section 4.7.7)

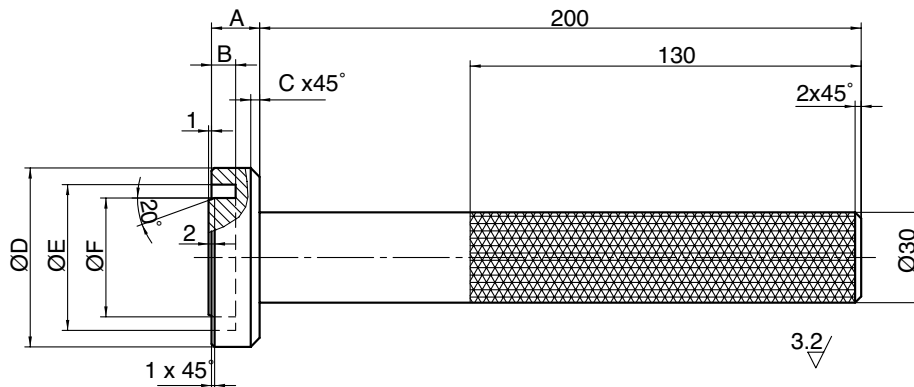

Pump type	Article number	A	B	C	Ø D	Ø E	Ø F
TW1	3.94943.11	15	7	2	38.3	28.5	20.5
TW2	3.94944.11	16	8	3	59.5	48.5	39.5
TW3	3.94945.11	20	10	5	69.5	60.5	48.5
TW4	3.94946.11	25	12	5	97.5	89.5	74.5

All dimensions in mm

5.5 Assembly tool for V-seal

Place: Endcover rear end

Purpose: For fitting the axial lip seal (0881) on the drive shaft (see section 4.7.7)

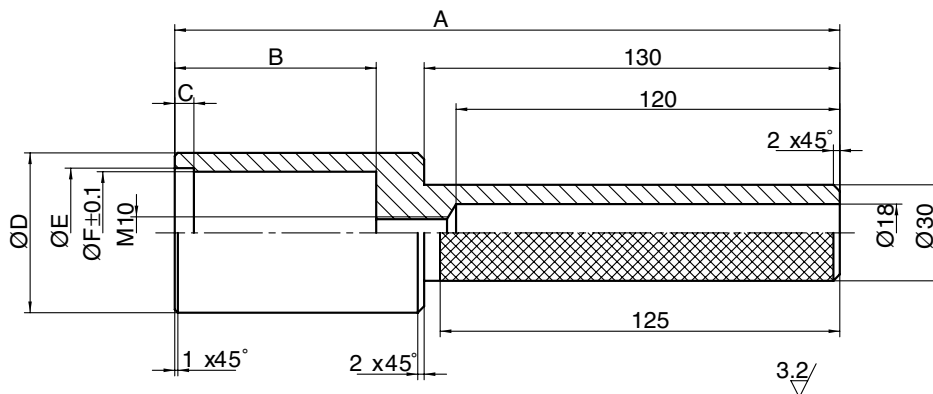

Pump type	Article number	A	B	C	Ø D	Ø E	Ø F ± 0.1
TW1	3.94947.11	177	32	6	30	20.5	19.2
TW2	3.94948.11	208	63	6	50	40.5	38.2
TW3	3.94949.11	235	90	10	60	50.5	48.2
TW4	3.94950.11	295	150	10	85	75.5	70.2

All dimensions in mm

5.6 Tool kit for synchronization of the pump shafts

Purpose: To adjust the position of the shafts against each other (see section 4.7.6.2)

The tools are to be used only for standard Bi-wing rotor pumps.

For multi-lobe rotors, other procedure is required, see 4.7.6.1.

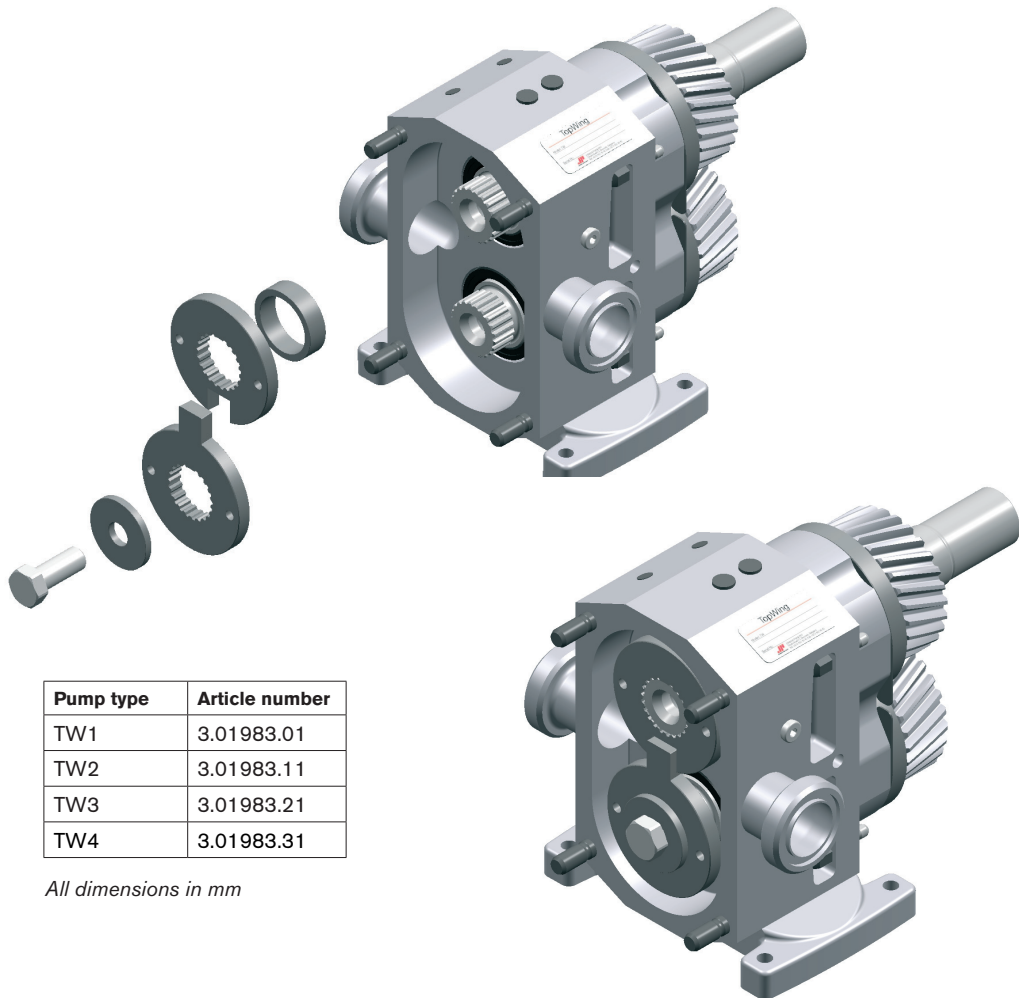

Pump type	Article number
TW1	3.01983.01
TW2	3.01983.11
TW3	3.01983.21
TW4	3.01983.31

All dimensions in mm

5.7 Tool for disassembly O-ring seal TW1

Purpose: To disassemble the support ring from the rotor case (see sections 4.6.2.4 and 4.6.2.5)

Pump type	Article number
TW1	3.94998.11



6.0 Sectional drawings and parts list

6.1 Overview

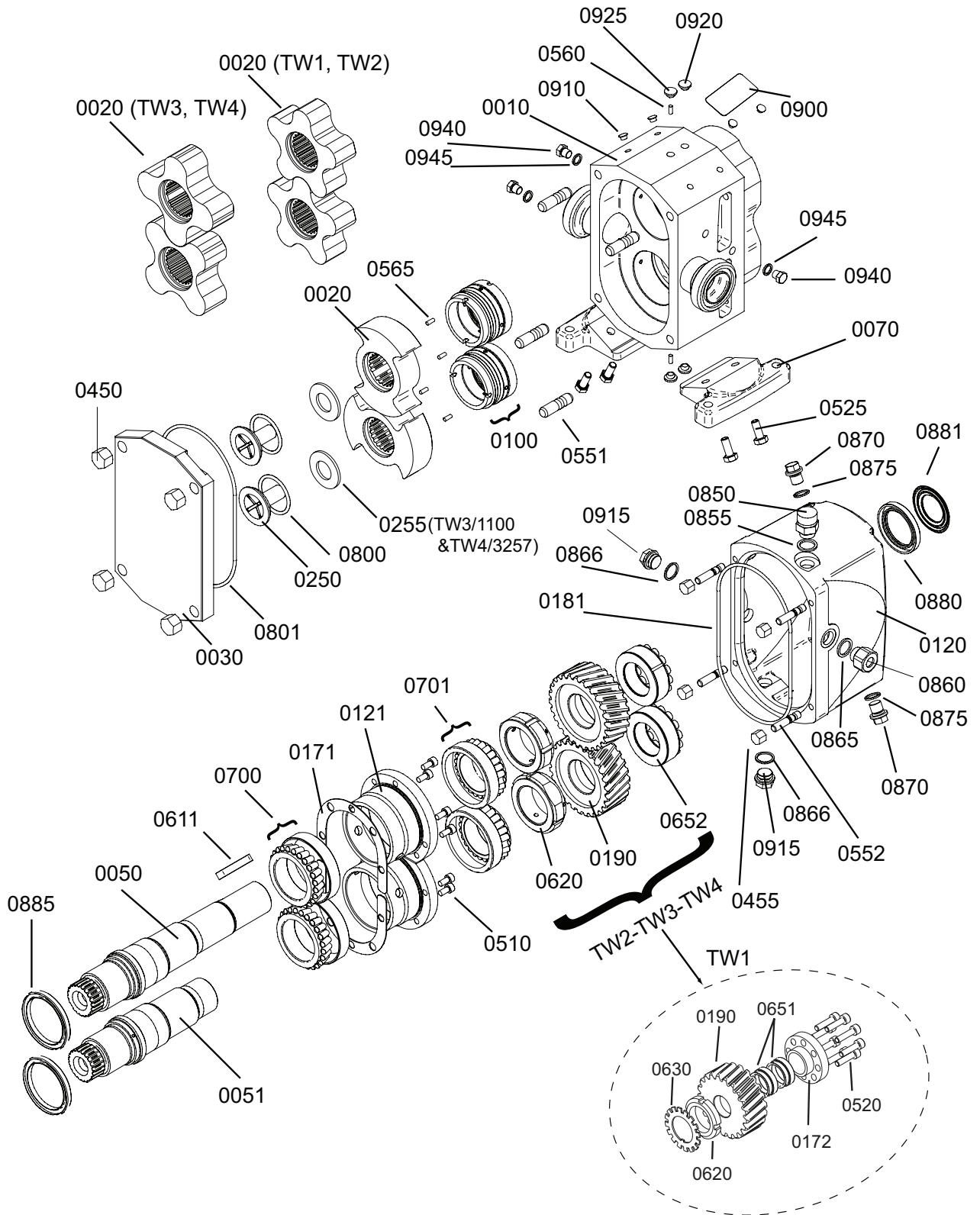

6.2 Recommended spare parts

Pos.	Nos./pump	Description	For preventive service for the next coming 3 years	Complete overhaul
0010	1	Rotor case		
0020	2	Rotor		
0030	1	Pump cover		
0030	1	Pump cover for heating		
0032	1	Pump cover valve		
0032	1	Pump cover valve for heating		
0050	1	Drive shaft		
0051	1	Lay shaft		
0070	2	Foot		
0082	2	O-ring	x	x
0083	2	O-ring	x	x
0085	2	O-ring	x	x
0085	4	O-ring	x	x
0086	2	O-ring	x	x
0087	2	O-ring	x	x
0097	2	Support ring		
0100	2	Seal	x	x
0120	1	End cover		
0121	2	Bearing holder		
0130	2	Shaft sleeve		
0171	2	Shim	x	x
0172	2	Pressure flange (TW1 only)		
0175	1	Support ring		
0181	1	O-ring	x	x
0183	2	O-ring	x	x
0183	4	O-ring	x	x
0190	1	Gear, set		x
0200	1	Valve head		
0210	1	Baseplate		
0220	1	Cylinder		
0230	1	Piston		
0240	1	Cover		
0250	2	Retainer		
0251	1	Spring adjusting screw		
0255	2	Spring washer		
0260	1	Spacer sleeve		
0450	4	Cap nut		
0455	4	Cap nut		
0510	6	Screw		
0520	16	Screw (TW1 only)		
0522	1	Screw		
0523	4	Screw		
0525	4	Screw		
0543	1	Spring adjusting plate		
0551	4	Stud bolt		
0552	4	Stud bolt		
0560	2	Pin		
0562	1	Pin		
0563	2	Pin		
0565	4	Pin		
0566	2	Pin		
0611	1	Key	x	x
0620	2	Locking nut		
0630	2	Locking washer (TW1 only)		
0651	4	Locking elements (TW1 only)		x
0652	2	Locking assembly		x

Recommended spare parts (continue)

Pos.	Nos./pump	Description	For preventive service for the next coming 3 years	Complete overhaul
0700	2	Taper roller bearing		x
0701	2	Taper roller bearing		x
0750	1	Spring		
0800	2	O-ring	x	x
0801	1	O-ring	x	x
0807	1	O-ring	x	x
0808	1	O-ring	x	x
0809	1	O-ring	x	x
0810	2	O-ring	x	x
0811	2	O-ring	x	x
0850	1	Air breather		
0855	1	Sealing ring	x	x
0860	1	Oil level glass		
0865	1	Sealing ring	x	x
0866	2	Sealing ring	x	x
0870	2	Drain plug		
0875	2	Sealing ring	x	x
0880	1	Lip seal	x	x
0881	1	V-seal	x	
0885	2	Lip seal	x	x
0890	2	Lip seal	x	x
0900	1	Name plate		
0910	4	Plastic plug		
0915	2	Plug		
0920	2	Plastic plug		
0921	1	Plastic plug		
0921	2	Plastic plug		
0922	1	Plastic plug		
0923	1	Plug (only TW4)		
0924	1	Elastic sealing ring (only TW4)	x	x
0925	2	Plastic plug		
0930	4	Plug		
0940	1	Plug (TW1)		
0940	2	Plug (TW2-TW3-TW4)		
0945	1	Elastic sealing ring (TW1)	x	x
0945	2	Elastic sealing ring (TW2-TW3-TW4)	x	x
0950	4	Male stud elbow		
	1	Tool for disassembly O-ring seal (only TW1)		
	1	Retainer tool		

6.3 Hydraulic part

6.3.1 Hydraulic part, complete

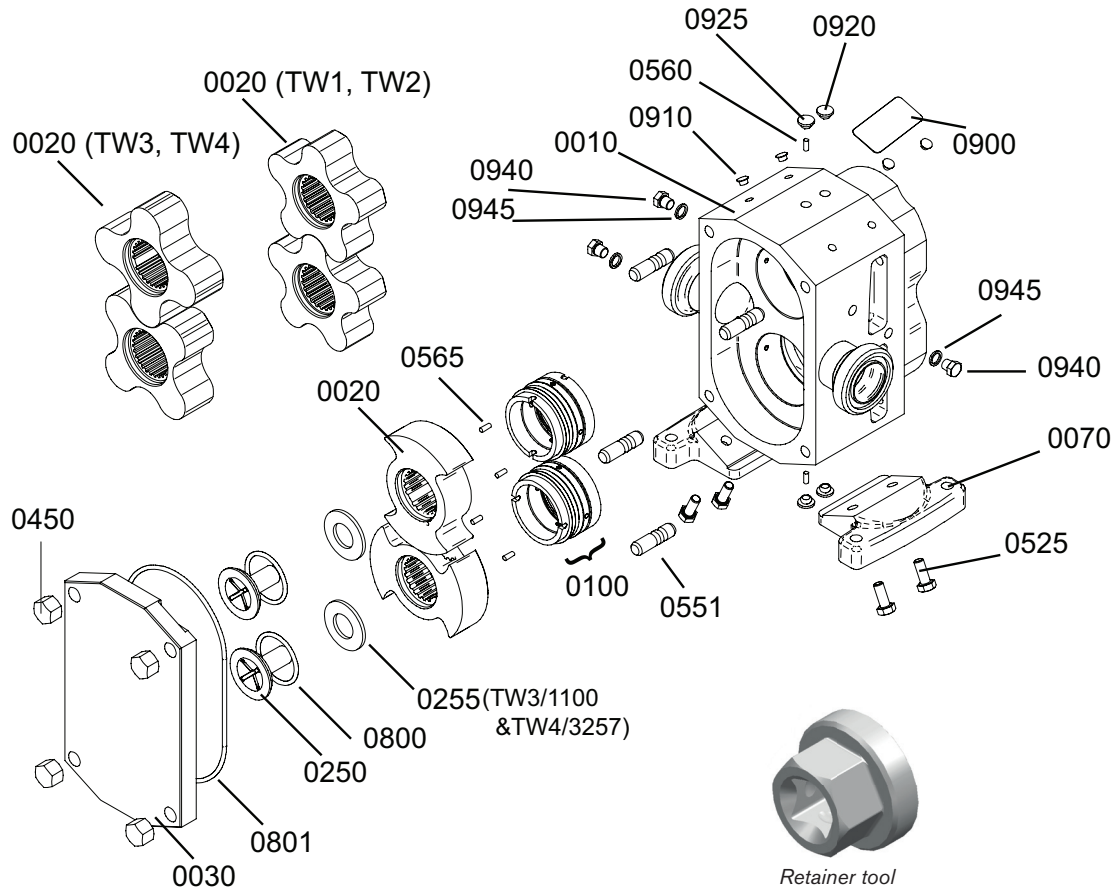

Pos.	Nos./ pump	Description	TW1/0041	TW1/0082	TW2/0171	TW2/0343	TW3/0537	TW3/1100	TW4/1629	TW4/3257
0010	1	Rotor case	3.14086.11	3.14087.11	3.14081.11	3.14082.11	3.14092.11	3.14093.11	3.14097.11	3.14098.11
0020	2	Rotor	see rotor complete							
0030	1	Pump cover	see pump cover options							
0070	2	Foot	see feet options							
0100	2	Seal	see seal options							
0250	2	Retainer	3.94407.31	3.94810.31	3.94422.31	3.94811.31	3.94454.31	3.94455.31	3.94797.31	3.94798.31
0255	2	Spring washer	-		-		-	0.0354.021	-	0.0354.020
0450	4	Cap nut	0.0205.783		0.0205.785		0.0205.787		0.0205.789	
0525	4	Screw	see feet options							
0551	4	Stud bolt	0.0012.912		3.94549.11		0.0012.952		0.0012.979	
0560	2	Pin	0.0490.653		0.0490.654		0.0490.654		0.0490.667	
0565	4	Pin	see rotor complete							
0900	1	Name plate	4.0030.141		4.0030.141		4.0030.140		4.0030.140	
0910	4	Plastic plug	3.94865.11		3.94481.12		3.94615.12		3.94562.12	
0920	2	Plastic plug	-		3.94615.12		3.94562.12		3.94563.12	
0925	2	Plastic plug	3.94481.12		3.94615.12		3.94615.12		3.94562.12	
0940		Plug	0.0625.061 (1)		0.0625.061 (2)		0.0625.061 (2)		0.0625.062 (2)	
0945		Sealing ring	4A3483.113 (1)		4A3483.113 (2)		4A3483.113 (2)		4A3483.114 (2)	
	1	Retainer tool	3.94550.31		3.94551.31		3.94555.31		3.94555.31	

O-ring kit for hydraulic part see 6.3.2.1

6.3.2 TopKits options

6.3.2.1 O-ring kit for hydraulic part

Note: Only FDA O-rings are approved for food applications

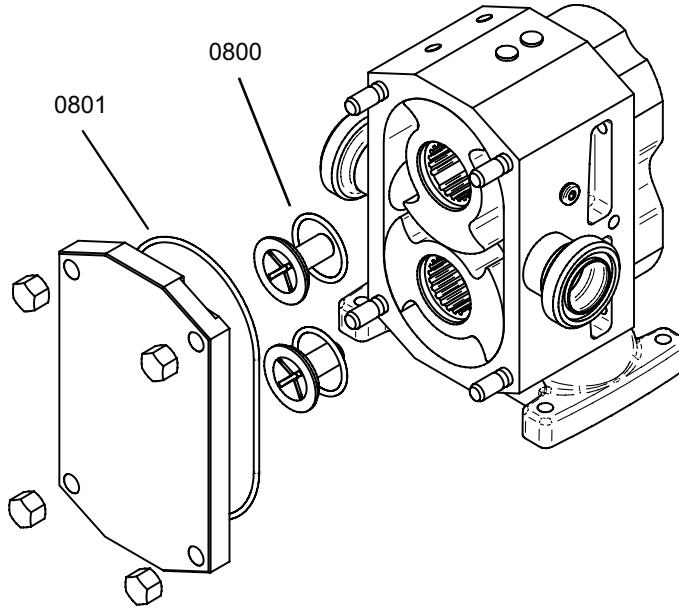

Pos.	Nos./pump	Description	TW1	TW2	TW3	TW4
O-ring kit FPM			3.01884.11	3.01885.11	3.01886.11	3.01887.11
0800	2	O-ring	3.91864.11	0.2173.939	0.2173.950	0.2173.853
0801	1	O-ring	0.2173.935	0.2173.991	0.2173.852	0.2173.857
O-ring kit EPDM			3.01884.12	3.01885.12	3.01886.12	3.01887.12
0800	2	O-ring	0.2173.074	0.2173.083	0.2173.141	0.2173.147
0801	1	O-ring	0.2173.104	0.2173.120	0.2173.130	0.2173.194
O-ring kit PTFE			3.01884.13	3.01885.13	3.01886.13	3.01887.13
0800	2	O-ring	0.2173.804	0.2173.800	0.2173.811	0.2173.828
0801	1	O-ring	0.2173.809	0.2173.826	0.2173.827	0.2173.829
O-ring kit CHEMRAZ®			3.01884.14	3.01885.14	3.01886.14	3.01887.14
0800	2	O-ring	0.2173.721	0.2173.725	0.2173.732	0.2173.759
0801	1	O-ring	0.2173.718	0.2173.757	0.2173.758	0.2173.763
* O-ring kit KALREZ®			3.01884.15	3.01885.15	3.01886.15	3.01887.15
0800	2	O-ring	0.2173.604	0.2173.608	0.2173.612	0.2173.650
0801	1	O-ring	0.2173.601	0.2173.648	0.2173.649	0.2173.654
O-ring kit FPM-FDA			3.01884.21	3.01885.21	3.01886.21	3.01887.21
0800	2	O-ring	0.2174.871	0.2174.895	0.2174.878	0.2174.821
0801	1	O-ring	0.2174.881	0.2174.823	0.2174.879	0.2174.822
O-ring kit EPDM-FDA			3.01884.16	3.01885.16	3.01886.16	3.01887.16
0800	2	O-ring	0.2173.501	0.2173.508	0.2173.517	0.2173.526
0801	1	O-ring	0.2173.502	0.2173.509	0.2173.518	0.2173.527
O-ring kit EPDM-FDA, USP Class VI, 3-A, AFO			3.01884.18	3.01885.18	3.01886.18	3.01887.18
0800	2	O-ring	0.2173.770	0.2173.776	0.2173.782	0.2173.788
0801	1	O-ring	0.2173.771	0.2173.777	0.2173.783	0.2173.789
		Certificate				
O-ring kit FPM-FDA, USP Class VI, 3-A, AFO			3.01884.19	3.01885.19	3.01886.19	3.01887.19
0800	2	O-ring	0.2173.772	0.2173.778	0.2173.784	0.2173.790
0801	1	O-ring	0.2173.773	0.2173.779	0.2173.785	0.2173.791
		Certificate				
O-ring kit Perfluor-FDA, USP Class VI, 3-A, AFO			3.01884.20	3.01885.20	3.01886.20	3.01887.20
0800	2	O-ring	0.2173.774	0.2173.780	0.2173.786	0.2173.792
0801	1	O-ring	0.2173.775	0.2173.781	0.2173.787	0.2173.793
		Certificate				

* Kalrez is a registered trademark of DuPont Performance Elastomers.

6.3.2.2 O-ring kit for hydraulic part with safety relief valve

Note: Only FDA O-rings are approved for food applications

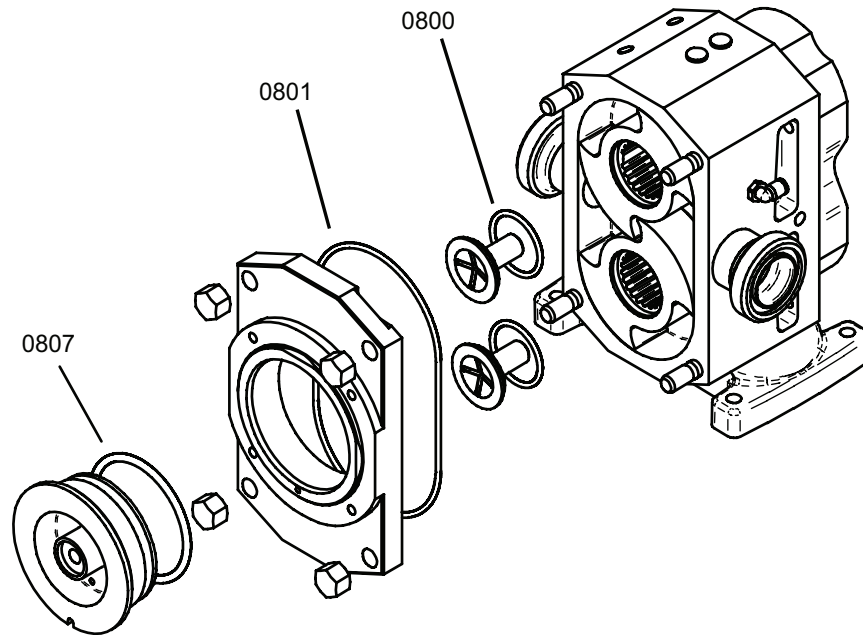

Pos.	Nos./pump	Description	TW1	TW2	TW3	TW4
O-ring kit FPM			3.01888.11	3.01889.11	3.01890.11	3.01891.11
0800	2	O-ring	3.91864.11	0.2173.939	0.2173.950	0.2173.853
0801	1	O-ring	0.2173.935	0.2173.991	0.2173.852	0.2173.857
0807	1	O-ring	0.2173.974	0.2173.969	0.2173.976	0.2173.980
O-ring kit EPDM			3.01888.12	3.01889.12	3.01890.12	3.01891.12
0800	2	O-ring	0.2173.074	0.2173.083	0.2173.141	0.2173.147
0801	1	O-ring	0.2173.104	0.2173.120	0.2173.130	0.2173.194
0807	1	O-ring	0.2173.087	0.2173.149	0.2173.169	0.2173.179
O-ring kit PTFE			3.01888.13	3.01889.13	3.01890.13	3.01891.13
0800	2	O-ring	0.2173.804	0.2173.800	0.2173.811	0.2173.828
0801	1	O-ring	0.2173.809	0.2173.826	0.2173.827	0.2173.829
0807	1	O-ring (**)	0.2173.736	0.2173.731	0.2173.740	0.2173.741
O-ring kit CHEMRAZ®			3.01888.14	3.01889.14	3.01890.14	3.01891.14
0800	2	O-ring	0.2173.721	0.2173.725	0.2173.732	0.2173.759
0801	1	O-ring	0.2173.718	0.2173.757	0.2173.758	0.2173.763
0807	1	O-ring	0.2173.736	0.2173.731	0.2173.740	0.2173.741
* O-ring kit KALREZ®			3.01888.15	3.01889.15	3.01890.15	3.01891.15
0800	2	O-ring	0.2173.604	0.2173.608	0.2173.612	0.2173.650
0801	1	O-ring	0.2173.601	0.2173.648	0.2173.649	0.2173.654
0807	1	O-ring	0.2173.627	0.2173.623	0.2173.631	0.2173.632
O-ring kit FPM-FDA			3.01888.21	3.01889.21	3.01890.21	3.01891.21
0800	2	O-ring	0.2174.871	0.2174.895	0.2174.878	0.2174.821
0801	1	O-ring	0.2174.881	0.2174.823	0.2174.879	0.2174.822
0807	1	O-ring	0.2174.920	0.2174.875	0.2174.828	0.2174.930
O-ring kit EPDM-FDA			3.01888.16	3.01889.16	3.01890.16	3.01891.16
0800	2	O-ring	0.2173.501	0.2173.508	0.2173.517	0.2173.526
0801	1	O-ring	0.2173.502	0.2173.509	0.2173.518	0.2173.527
0807	1	O-ring	0.2173.503	0.2173.510	0.2173.519	0.2173.528

(**) Pos 0807 is of Chemraz®

* Kalrez is a registered trademark of DuPont Performance Elastomers.

6.3.3 Rotor complete

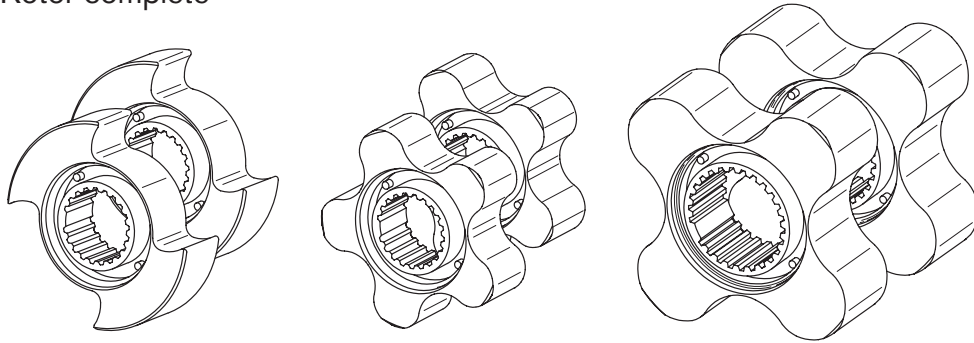

Rotor set complete with pins			TW1/0041	TW1/0082	TW2/0171	TW2/0343
Shape	Clearances					
wing	standard	W1	3.52855.01	3.52856.01	3.52857.01	3.52858.01
multi-lobe	standard	M1	3.52855.11	3.52856.11	3.52857.11	3.52858.11

Rotor set complete with pins			TW3/0537	TW3/1100	TW4/1629	TW4/3257
Shape	Clearances					
wing	standard	W1	3.52859.01	3.52860.01	3.52861.01	3.52862.01
multi-lobe	standard	M1	3.52859.11	3.52860.11	3.52861.11	3.52862.11

6.3.4 Pump cover options

6.3.4.1 Flat pump cover

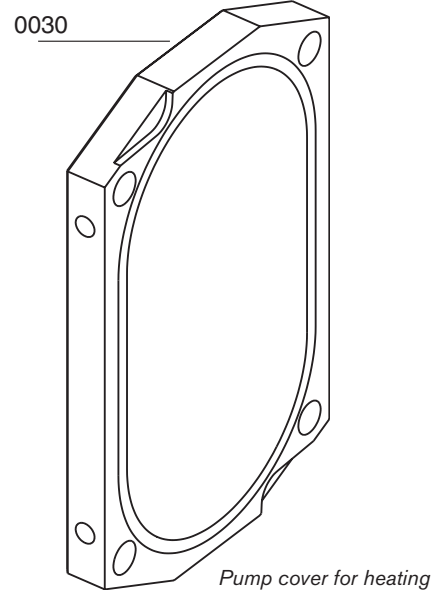
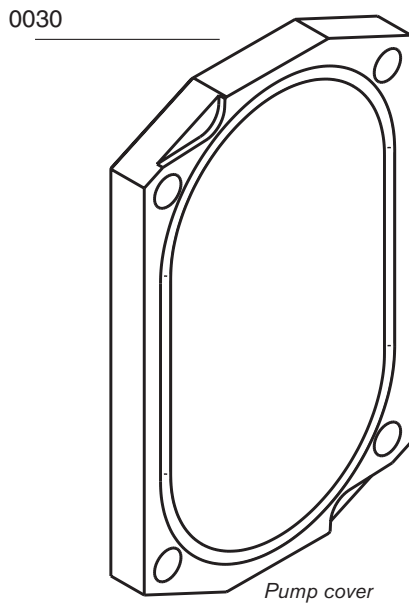

Pos.	Nos./pump	Description	TW1	TW2	TW3	TW4
0030	1	Pump cover	3.94781.21	3.94771.21	3.94784.21	3.94799.21
0030	1	Pump cover for heating	3.94781.22	3.94771.22	3.94784.22	3.94799.22

Dimension of Heating connections for all pump sizes: G1/8"

6.3.5 Feet options

Horizontal

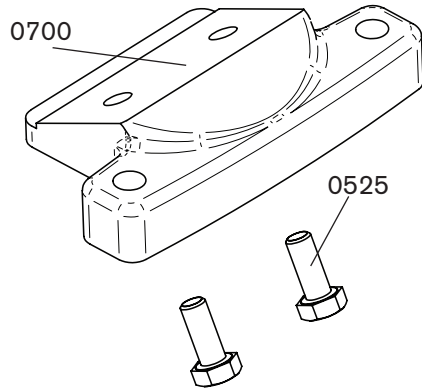

Vertical

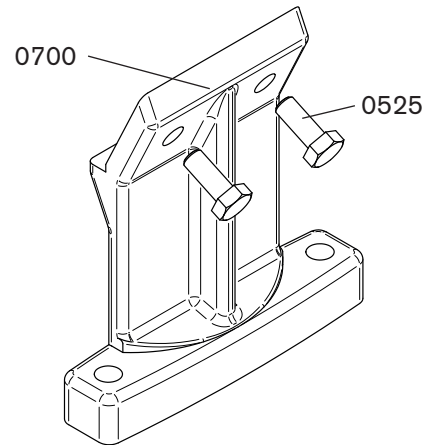

Pos.	Nos./pump	Description	TW1	TW2	TW3	TW4
0070	2	Foot – horizontal	3.14088.11	3.14083.11	3.14094.11	3.14099.11
0070	2	Foot – vertical	3.14089.11	3.14084.11	3.14095.11	3.14100.11
0525	4	Screw – horizontal	0.0252.134	0.0252.602	0.0138.953	0.0138.965
0525	4	Screw – vertical	0.0252.601	0.0252.602	0.0252.603	0.0252.604

6.4 Drive assembly

6.4.1 Drive assembly, complete

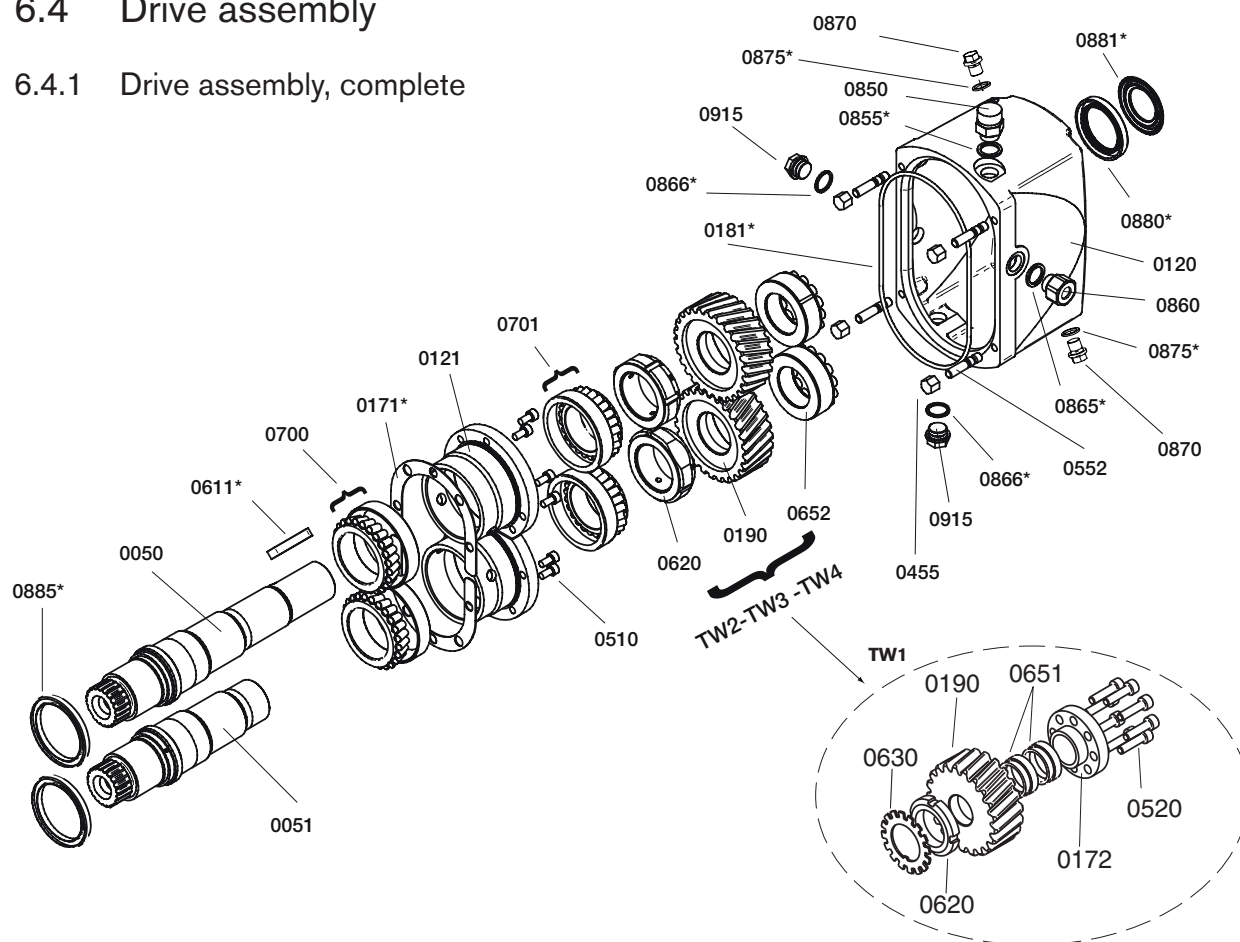

Pos.	Nos./ pump	Description	TW1	TW2	TW3/0357	TW3/1100	TW4/1629	TW4/3257
0050	1	Drive shaft	3.94775.11	3.94766.11	3.94787.11	3.94787.31	3.94790.11	3.94790.31
0051	1	Lay shaft	3.94776.11	3.94767.11	3.94788.11	3.94788.31	3.94791.11	3.94791.31
0120	1	Endcover	3.14085.11	3.14080.11	3.14090.11		3.14096.11	
0121	2	Bearing holder	3.94805.11	3.94768.11	3.94789.11		3.94792.11	
0172	2	Pressure flange	3.94384.11	–	–		–	
0190	1	Gear, set	3.01869.11	3.01868.11	3.01870.11		3.01892.11	
0455	4	Cap nut	0.0205.782	0.0205.783	0.0205.784	0.0205.785		
0510	6	Screw	0.0251.428	0.0251.201	0.0257.036		0.0251.255	
0520	16	Screw	0.0251.890	–	–		–	
0552	4	Stud bolt	0.0012.903	0.0012.914	0.0012.924		0.0012.934	
0620	2	Locking nut	0.0243.005	3.94774.11	0.0243.111		0.0243.116	
0630	2	Locking washer	0.0383.005	–	–		–	
0651	4	Locking elements	0.0983.011	–	–		–	
0652	2	Locking assembly	–	0.0983.120	0.0983.124		0.0983.132	
0700	2	Taper roller bearing	0.3428.903	0.3428.901	0.3428.905		0.3428.907	
0701	2	Taper roller bearing	0.3428.904	0.3428.902	0.3428.906		0.3428.908	
0850	1	Air breather	3.94438.11	3.94438.11	3.94438.11		3.94438.11	
0860	1	Oil level glass	3.94439.11	3.94439.11	3.94439.11		3.94439.11	
0870	2	Drain plug	0.0625.062	0.0625.062	0.0625.062		3.94917.11	
0915	2	Plug	3.94917.11	3.94917.11	3.94917.11		3.94917.11	
*	1	Service kit	Service kit for drive assembly, see 6.4.2					
	1	Key protection	3.94665.11	3.94667.11	3.94868.11		3.94867.11	

6.4.2 Service kit for drive assembly

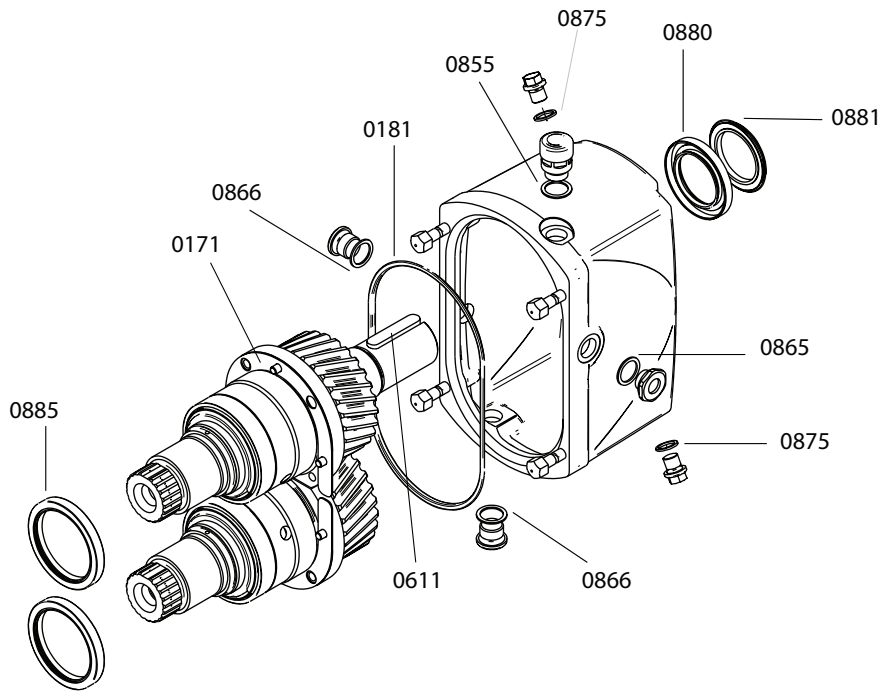

Pos.	Nos./pump	Description	TW1	TW2	TW3	TW4
Service kit			3.01894.11	3.01895.11	3.01896.11	3.01897.11
0171	2	Shim	3.94806.11	3.94804.11	3.94807.11	3.94808.11
0181	1	O-ring	0.2172.903	0.2172.620	0.2172.629	0.2172.933
0611	1	Key	0.0502.025	0.0502.050	0.0502.077	0.0502.285
0855	1	Sealing ring	3.94962.11	3.94962.11	3.94962.11	3.94962.11
0865	1	Sealing ring	3.94962.11	3.94962.11	3.94962.11	3.94962.11
0866	2	Sealing ring	3.94962.11	3.94962.11	0.2189.460	0.2189.460
0875	2	Sealing ring	0.2198.001	0.2198.001	0.2198.001	0.2189.460
0880	1	Lip seal	0.2234.700	0.2234.701	0.2234.703	0.2234.702
0881	1	V-seal	0.2230.417	0.2230.424	0.2230.469	0.2230.466
0885	2	Lip seal	0.2234.913	0.2234.910	0.2234.914	0.2234.915

7.0 Single mechanical seal with/without flushing

7.1 General information

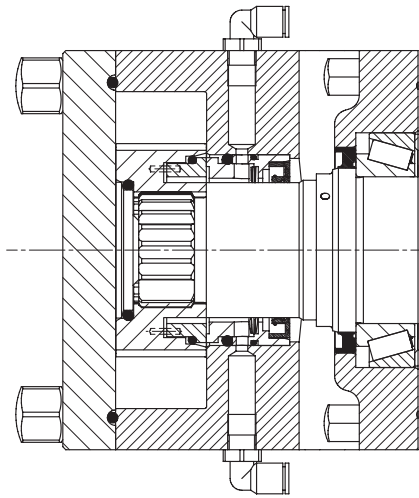

Single mechanical seal with flushing

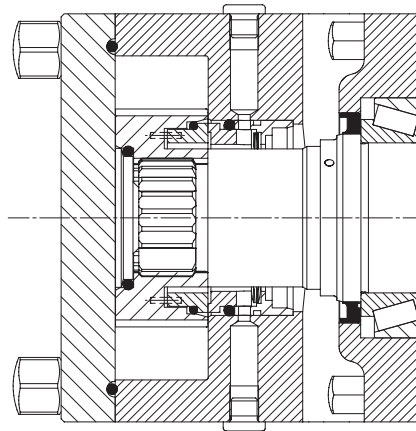

Single mechanical seal without flushing

Seal information

- Balanced mechanical seal hygienic design
- The spring loaded stationary part is fixed in the rotor case (pusher type seal)
- Rotating seat is built into the rotor and is locked by means of pins and slot
- Suitable for both directions of rotation
- Small seal faces prevents solidifying of medium between seal faces
- Sliding faces are mounted flexibly in O-rings
- Seal faces are available in two different material combinations
- Enclosed spring outside of pumped medium (can be flushed)
- Low pressure quench or flushing possible if seal is equipped with extra lip seal

Technical data

Materials of mechanical seal faces: GW1 and GW2: SiC (Q1) - SiC (Q1)
GB1 and GB2: SiC (Q1) - Carbon (B)

Materials of O-rings: Fluorocarbon FPM
FPM-FDA (V1 i.e. certified food quality)
EPDM (E)
EPDM-FDA (E1 i.e. certified food quality)
Perfluor Chemraz® (C)
* Perfluor Kalrez® (K)

EPDM-FDA, USP Class VI, 3-A, AFO
FPM-FDA, USP Class VI, 3-A, AFO
Perfluor-FDA, USP Class VI, 3-A, AFO

Material of lip ring (optional): Nitrile rubber (P)

Maximum temperature: 200°C or up to the temperature limit of the pump

Maximum pressure: 16 bar or up to the operating pressure limit of the pump

Hydrostatic test pressure: 25 bar (for mechanical seal)

Maximum pressure of quench/flushing medium: 0.5 bar

* Kalrez is a registered trademark of DuPont Performance Elastomers.

7.2 Seal options

7.2.1 Single mechanical seal

Note: Only FDA O-rings are approved for food applications

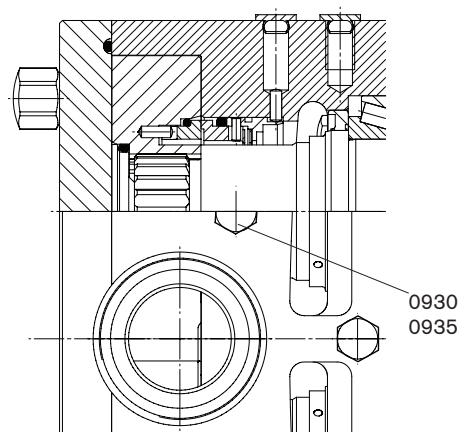
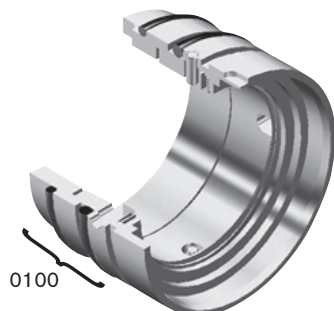

Pos.	Nos./pump	Description	TW1	TW2	TW3	TW4
0100	2	Single mech seal SiC/SiC/FPM	3.94755.11	3.94751.11	3.94759.11	3.94763.11
0100	2	Single mech seal SiC/C/FPM	3.94754.11	3.94750.11	3.94758.11	3.94762.11
0100	2	Single mech seal SiC/SiC/EPDM	3.94823.11	3.94825.11	3.94827.11	3.94829.11
0100	2	Single mech seal SiC/C/EPDM	3.94824.11	3.94826.11	3.94828.11	3.94830.11
0100	2	Single mech seal SiC/SiC/Chemraz®	3.94831.11	3.94833.11	3.94835.11	3.94837.11
0100	2	Single mech seal SiC/C/Chemraz®	3.94832.11	3.94834.11	3.94836.11	3.94838.11
0100	2	* Single mech seal SiC/SiC/Kalrez®	3.94839.11	3.94841.11	3.94843.11	3.94845.11
0100	2	* Single mech seal SiC/C/Kalrez®	3.94840.11	3.94842.11	3.94844.11	3.94846.11
0100	2	Single mech seal SiC/SiC/FPM-FDA	3.94755.15	3.94751.15	3.94759.15	3.94763.15
0100	2	Single mech seal SiC/C/FPM-FDA	3.94754.15	3.94750.15	3.94758.15	3.94762.15
0100	2	Single mech seal SiC/SiC/EPDM-FDA	3.94823.15	3.94825.15	3.94827.15	3.94829.15
0100	2	Single mech seal SiC/C/EPDM-FDA	3.94824.15	3.94826.15	3.94828.15	3.94830.15
0100	2	Single mech seal SiC/SiC/EPDM-FDA, USP Class VI, 3-A, AFO	3.94823.18	3.94826.18	3.94827.18	3.94829.18
0100	2	Single mech seal SiC/C/EPDM-FDA, USP Class VI, 3-A, AFO	3.94823.19	3.94826.19	3.94827.19	3.94829.19
0100	2	Single mech seal SiC/SiC/FPM-FDA, USP Class VI, 3-A, AFO	3.94823.20	3.94826.20	3.94827.20	3.94829.20
0100	2	Single mech seal SiC/C/FPM-FDA, USP Class VI, 3-A, AFO	3.94823.21	3.94826.21	3.94827.21	3.94829.21
0100	2	Single mech seal SiC/SiC/Perfluor-FDA, USP Class VI, 3-A, AFO	3.94823.22	3.94826.22	3.94827.22	3.94829.22
0100	2	Single mech seal SiC/C/Perfluor-FDA, USP Class VI, 3-A, AFO	3.94823.23	3.94826.23	3.94827.23	3.94829.23
0930	4	Plug	0.0625.061	0.0625.061	0.0625.061	0.0625.061
0935	4	Sealing ring	4A3483.113	4A3483.113	4A3483.113	4A3483.113

O-ring kit for single mechanical seal, see 7.3.1

* Kalrez is a registered trademark of DuPont Performance Elastomers.

7.2.2 Single mechanical seal with flushing

Note: Only FDA O-rings are approved for food applications

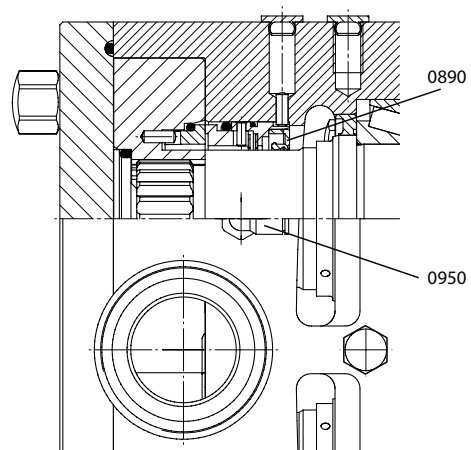
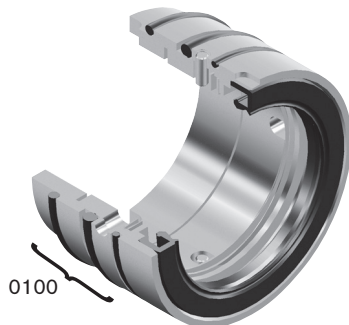

Pos.	Nos./pump	Description	TW1	TW2	TW3	TW4
0100	2	Single mech seal SiC/SiC/FPM	3.94755.11	3.94751.11	3.94759.11	3.94763.11
0100	2	Single mech seal SiC/C/FPM	3.94754.11	3.94750.11	3.94758.11	3.94762.11
0100	2	Single mech seal SiC/SiC/EPDM	3.94823.12	3.94825.12	3.94827.12	3.94829.12
0100	2	Single mech seal SiC/C/EPDM	3.94824.12	3.94826.12	3.94828.12	3.94830.12
0100	2	Single mech seal SiC/SiC/Chemraz®	3.94831.12	3.94833.12	3.94835.12	3.94837.12
0100	2	Single mech seal SiC/C/Chemraz®	3.94832.12	3.94834.12	3.94836.12	3.94838.12
0100	2	* Single mech seal SiC/SiC/Kalrez®	3.94839.12	3.94841.12	3.94843.12	3.94845.12
0100	2	* Single mech seal SiC/C/Kalrez®	3.94840.12	3.94842.12	3.94844.12	3.94846.12
0100	2	Single mech seal SiC/SiC/FPM-FDA	3.94755.16	3.94751.16	3.94759.16	3.94763.16
0100	2	Single mech seal SiC/C/FPM-FDA	3.94754.16	3.94750.16	3.94758.16	3.94762.16
0100	2	Single mech seal SiC/SiC/EPDM-FDA	3.94823.16	3.94825.16	3.94827.16	3.94829.16
0100	2	Single mech seal SiC/C/EPDM-FDA	3.94824.16	3.94826.16	3.94828.16	3.94830.16
0100	2	Single mech seal SiC/SiC/EPDM-FDA, USP Class VI, 3-A, AFO	3.94823.24	3.94826.24	3.94827.24	3.94829.24
0100	2	Single mech seal SiC/C/EPDM-FDA, USP Class VI, 3-A, AFO	3.94823.25	3.94826.25	3.94827.25	3.94829.25
0100	2	Single mech seal SiC/SiC/FPM-FDA, USP Class VI, 3-A, AFO	3.94823.26	3.94826.26	3.94827.26	3.94829.26
0100	2	Single mech seal SiC/C/FPM-FDA, USP Class VI, 3-A, AFO	3.94823.27	3.94826.27	3.94827.27	3.94829.27
0100	2	Single mech seal SiC/SiC/Perfluor-FDA, USP Class VI, 3-A, AFO	3.94823.28	3.94826.28	3.94827.28	3.94829.28
0100	2	Single mech seal SiC/C/Perfluor-FDA, USP Class VI, 3-A, AFO	3.94823.29	3.94826.29	3.94827.29	3.94829.29
0890	2	Lip seal NBR/SS	0.2234.905	0.2234.906	0.2234.907	0.2234.908
0950	4	Male stud elbow	3.94983.11	3.94983.11	3.94983.11	3.94983.11

O-ring kit for single mechanical seal with flushing, see 7.3.2

* Kalrez is a registered trademark of DuPont Performance Elastomers.

7.3 O-ring kits

7.3.1 Single mechanical seal

Note: Only FDA O-rings are approved for food applications

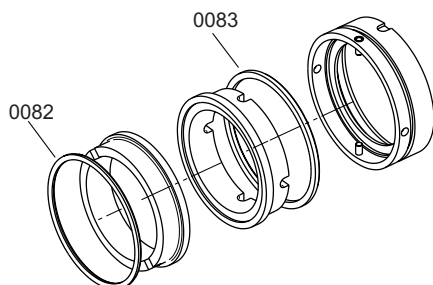

Pos.	Nos./pump	Description	TW1	TW2	TW3	TW4
O-ring kit FPM			3.01907.11	3.01908.11	3.01909.11	3.01910.11
0082	2	O-ring	0.2173.992	0.2173.994	0.2173.996	0.2173.972
0083	2	O-ring	0.2173.982	0.2173.995	0.2173.997	0.2173.998
O-ring kit EPDM			3.01907.12	3.01908.12	3.01909.12	3.01910.12
0082	2	O-ring	0.2173.048	0.2173.061	0.2173.206	0.2173.102
0083	2	O-ring	0.2173.082	0.2173.088	0.2173.093	0.2173.352
O-ring kit CHEMRAZ®			3.01907.13	3.01908.13	3.01909.13	3.01910.13
0082	2	O-ring	0.2173.742	0.2173.745	0.2173.747	0.2173.750
0083	2	O-ring	0.2173.743	0.2173.746	0.2173.748	0.2173.751
* O-ring kit KALREZ®			3.01907.14	3.01908.14	3.01909.14	3.01910.14
0082	2	O-ring	0.2173.633	0.2173.636	0.2173.638	0.2173.641
0083	2	O-ring	0.2173.634	0.2173.637	0.2173.639	0.2173.642
O-ring kit FPM-FDA			3.01907.20	3.01908.20	3.01909.20	3.01910.20
0082	2	O-ring	0.2174.932	0.2174.956	0.2174.876	0.2174.957
0083	2	O-ring	0.2174.931	0.2174.898	0.2174.877	0.2174.958
O-ring kit EPDM-FDA			3.01907.15	3.01908.15	3.01909.15	3.01910.15
0082	2	O-ring	0.2173.504	0.2173.511	0.2173.520	0.2173.529
0083	2	O-ring	0.2173.505	0.2173.512	0.2173.521	0.2173.530
O-ring kit EPDM-FDA, USP Class VI, 3-A, AFO			3.01907.17	3.01908.17	3.01909.17	3.01910.17
0082	2	O-ring	0.2174.001	0.2174.007	0.2174.013	0.2174.019
0083	2	O-ring	0.2174.002	0.2174.008	0.2174.014	0.2174.020
		Certificate				
O-ring kit FPM-FDA, USP Class VI, 3-A, AFO			3.01907.18	3.01908.18	3.01909.18	3.01910.18
0082	2	O-ring	0.2174.003	0.2174.009	0.2174.015	0.2174.021
0083	2	O-ring	0.2174.004	0.2174.010	0.2174.016	0.2174.022
		Certificate				
O-ring kit Perfluor-FDA, USP Class VI, 3-A, AFO			3.01907.19	3.01908.19	3.01909.19	3.01910.19
0082	2	O-ring	0.2174.005	0.2174.011	0.2174.017	0.2174.023
0083	2	O-ring	0.2174.006	0.2174.012	0.2174.018	0.2174.024
		Certificate				

* Kalrez is a registered trademark of DuPont Performance Elastomers.

7.3.2 Single mechanical seal with flushing

Note: Only FDA O-rings are approved for food applications

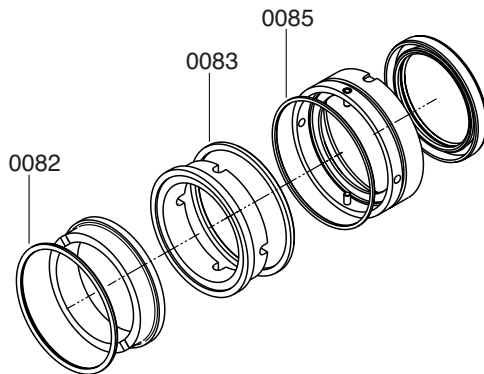

Pos.	Nos./pump	Description	TW1	TW2	TW3	TW4
O-ring kit FPM			3.01877.11	3.01878.11	3.01879.11	3.01880.11
0082	2	O-ring	0.2173.992	0.2173.994	0.2173.996	0.2173.972
0083	2	O-ring	0.2173.982	0.2173.995	0.2173.997	0.2173.998
0085	2	O-ring	0.2173.993	0.2173.914	0.2173.970	0.2173.948
O-ring kit EPDM			3.01877.12	3.01878.12	3.01879.12	3.01880.12
0082	2	O-ring	0.2173.048	0.2173.061	0.2173.206	0.2173.102
0083	2	O-ring	0.2173.082	0.2173.088	0.2173.093	0.2173.352
0085	2	O-ring	0.2173.241	0.2173.255	0.2173.242	0.2173.202
O-ring kit CHEMRAZ®			3.01877.13	3.01878.13	3.01879.13	3.01880.13
0082	2	O-ring	0.2173.742	0.2173.745	0.2173.747	0.2173.750
0083	2	O-ring	0.2173.743	0.2173.746	0.2173.748	0.2173.751
0085	2	O-ring	0.2173.744	0.2173.735	0.2173.749	0.2173.723
* O-ring kit KALREZ®			3.01877.14	3.01878.14	3.01879.14	3.01880.14
0082	2	O-ring	0.2173.633	0.2173.636	0.2173.638	0.2173.641
0083	2	O-ring	0.2173.634	0.2173.637	0.2173.639	0.2173.642
0085	2	O-ring	0.2173.635	0.2173.615	0.2173.640	0.2173.606
O-ring kit FPM-FDA			3.01877.20	3.01878.20	3.01879.20	3.01880.20
0082	2	O-ring	0.2174.932	0.2174.956	0.2174.876	0.2174.957
0083	2	O-ring	0.2174.931	0.2174.898	0.2174.877	0.2174.958
0085	2	O-ring	0.2174.959	0.2174.919	0.2174.960	0.2174.869
O-ring kit EPDM-FDA			3.01877.15	3.01878.15	3.01879.15	3.01880.15
0082	2	O-ring	0.2173.504	0.2173.511	0.2173.520	0.2173.529
0083	2	O-ring	0.2173.505	0.2173.512	0.2173.521	0.2173.530
0085	2	O-ring	0.2173.506	0.2173.513	0.2173.522	0.2173.531
O-ring kit EPDM-FDA, USP Class VI, 3-A, AFO			3.01877.17	3.01878.17	3.01879.17	3.01880.17
0082	2	O-ring	0.2174.001	0.2174.007	0.2174.013	0.2174.019
0083	2	O-ring	0.2174.002	0.2174.008	0.2174.014	0.2174.020
0085	2	O-ring	0.2174.030	0.2174.033	0.2174.036	0.2174.039
		Certificate				
O-ring kit FPM-FDA, USP Class VI, 3-A, AFO			3.01877.18	3.01878.18	3.01879.18	3.01880.18
0082	2	O-ring	0.2174.003	0.2174.009	0.2174.015	0.2174.021
0083	2	O-ring	0.2174.004	0.2174.010	0.2174.016	0.2174.022
0085	2	O-ring	0.2174.031	0.2174.034	0.2174.037	0.2174.040
		Certificate				
O-ring kit Perfluor-FDA, USP Class VI, 3-A, AFO			3.01877.19	3.01878.19	3.01879.19	3.01880.19
0082	2	O-ring	0.2174.005	0.2174.011	0.2174.017	0.2174.023
0083	2	O-ring	0.2174.006	0.2174.012	0.2174.018	0.2174.024
0085	2	O-ring	0.2174.032	0.2174.035	0.2174.038	0.2174.041
		Certificate				

* Kalrez is a registered trademark of DuPont Performance Elastomers.

8.0 Double mechanical seal

8.1 General information

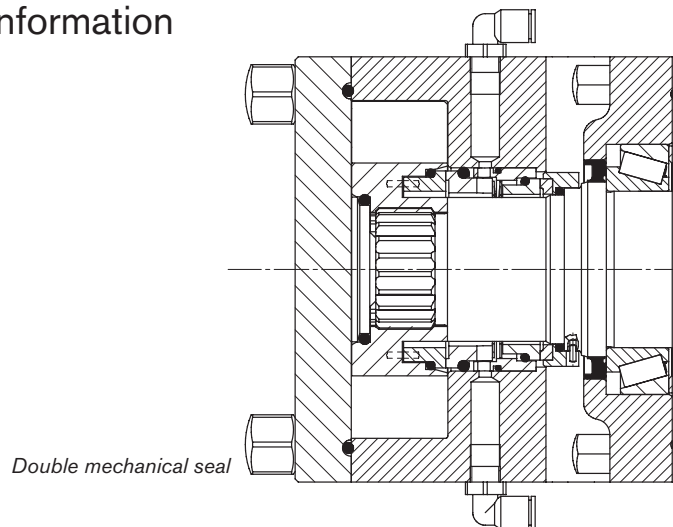

Seal information

- Balanced mechanical seal hygienic design
- The spring loaded stationary part is fixed in the rotor case (pusher type seal)
- Product side rotating seal is built into the rotor and is locked by means of pins and slot – the rotating seal on the atmospheric side is fixed and locked on the shaft
- Suitable for both directions of rotation
- Small seal faces prevents solidifying of medium between seal faces
- Sliding faces are mounted flexibly in O-rings
- Seal faces are available in two different material combinations
- Enclosed spring outside of pumped medium (can be flushed)
- Quenched or flushed, pressurized or un-pressurized

Technical data

Materials:	DW2:	Product side:	SiC (Q1) - SiC (Q1)
		Atmospheric side:	SiC (Q1) - Carbon (B)
	DB2:	Product side:	SiC (Q1) - Carbon (B)
		Atmospheric side:	SiC (Q1) - Carbon (B)

Materials of O-rings:	Fluorocarbon FPM (Fluoroelastomer)
	FPM-FDA (V1 i.e. certified food quality)
	EPDM (E)
	EPDM-FDA (E1 i.e. certified food quality)
	Perfluor Chemraz® (C)
	* Perfluor Kalrez® (K)
	EPDM-FDA, USP Class VI, 3-A, AFO
FPM-FDA, USP Class VI, 3-A, AFO	
Perfluor-FDA, USP Class VI, 3-A, AFO	

Temperature:	200°C or up to the temperature limit of the pump
Maximum pressure:	16 bar or up to the operating pressure limit of the pump
Hydrostatic test pressure:	25 bar (for mechanical seal)
Maximum pressure of quench/flushing medium:	16 bar
Pressurised seal:	The pressure of quench/flush medium should be 0.5 bar higher than the process pressure
Unpressurised seal:	Pressure is lower than or equal to the process pressure

* Kalrez is a registered trademark of DuPont Performance Elastomers.

8.2 Seal options

Note: Only FDA O-rings are approved for food applications

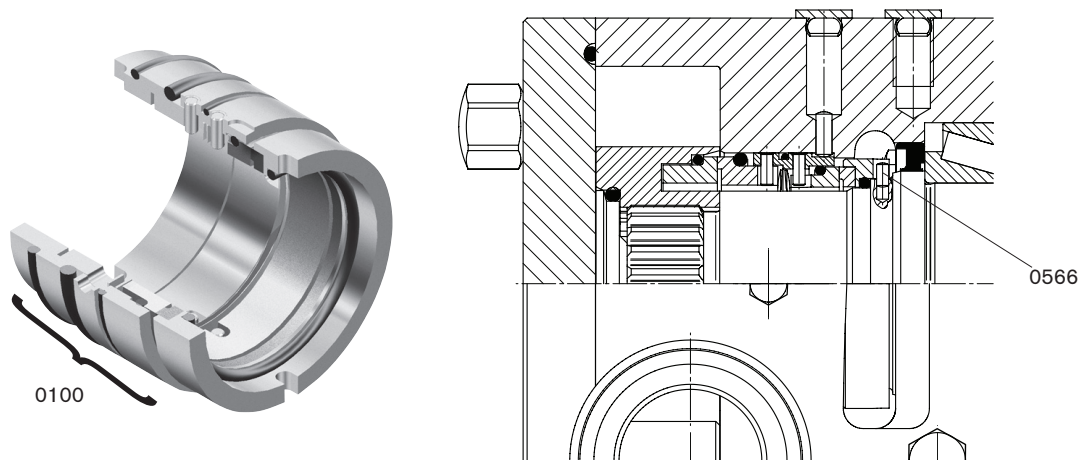

Pos.	Nos./pump	Description	TW2	TW3	TW4
0100	2	Double mech seal SiC/SiC/SiC/C/FPM	3.94753.11	3.94761.11	3.94765.11
0100	2	Double mech seal SiC/C/SiC/C/FPM	3.94752.11	3.94760.11	3.94764.11
0100	2	Double mech seal SiC/SiC/SiC/C/EPDM	3.94847.11	3.94849.11	3.94851.11
0100	2	Double mech seal SiC/C/SiC/C/EPDM	3.94848.11	3.94850.11	3.94852.11
0100	2	Double mech seal SiC/SiC/SiC/C/Chemraz®	3.94853.11	3.94855.11	3.94857.11
0100	2	Double mech seal SiC/C/SiC/C/Chemraz®	3.94854.11	3.94856.11	3.94858.11
0100	2	* Double mech seal SiC/SiC/SiC/C/Kalrez®	3.94859.11	3.94861.11	3.94863.11
0100	2	* Double mech seal SiC/C/SiC/C/Kalrez®	3.94860.11	3.94862.11	3.94864.11
0100	2	Double mech seal SiC/SiC/SiC/C/FPM-FDA	3.94753.15	3.94761.15	3.94765.15
0100	2	Double mech seal SiC/C/SiC/C/FPM -FDA	3.94752.15	3.94760.15	3.94764.15
0100	2	Double mech seal SiC/SiC/SiC/C/EPDM-FDA	3.94847.15	3.94849.15	3.94851.15
0100	2	Double mech seal SiC/C/SiC/C/EPDM-FDA	3.94848.15	3.94850.15	3.94852.15
0100	2	Double mech seal SiC/SiC/SiC/C/EPDM-FDA, USP Class VI, 3-A, AFO	3.94826.30	3.94827.30	3.94829.30
0100	2	Double mech seal SiC/C/SiC/C/EPDM-FDA, USP Class VI, 3-A, AFO	3.94826.31	3.94827.31	3.94829.31
0100	2	Double mech seal SiC/SiC/SiC/C//FPM-FDA, USP Class VI, 3-A, AFO	3.94826.32	3.94827.32	3.94829.32
0100	2	Double mech seal SiC/C/SiC/C/FPM-FDA, USP Class VI, 3-A, AFO	3.94826.33	3.94827.33	3.94829.33
0100	2	Double mech seal SiC/SiC/SiC/C/Perfluor-FDA, USP Class VI, 3-A, AFO	3.94826.34	3.94827.34	3.94829.34
0100	2	Double mech seal SiC/C/SiC/C/Perfluor-FDA, USP Class VI, 3-A, AFO	3.94826.35	3.94827.35	3.94829.35
0566	2	Pin	0.0490.641	0.0490.641	0.0490.654

O-ring kit for double mechanical seal, see 8.3

* Kalrez is a registered trademark of DuPont Performance Elastomers.

8.3 O-ring kits - Double mechanical seal

Note: Only FDA O-rings are approved for food applications

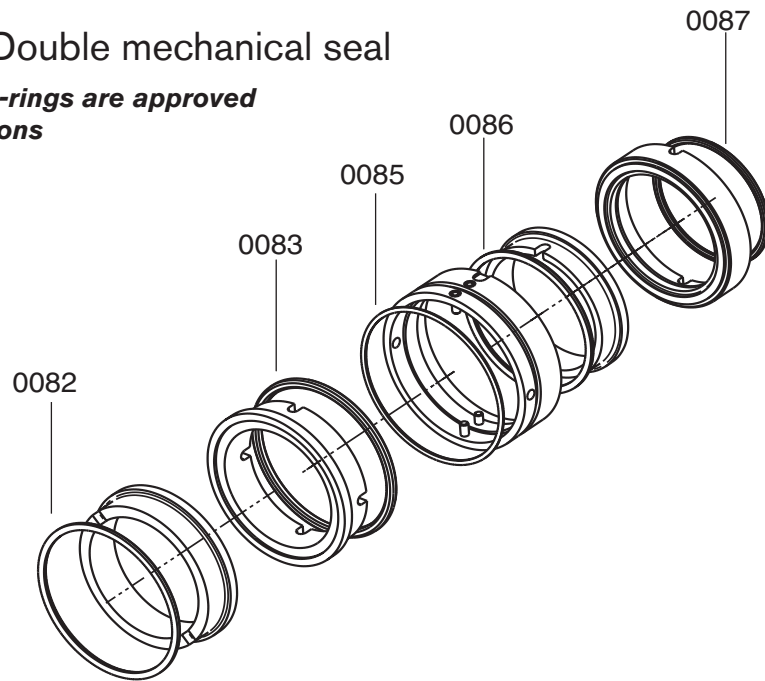

Pos.	Nos./ pump	Description	TW2	TW3	TW4
O-ring kit FPM			3.01881.11	3.01882.11	3.01883.11
0082	2	O-ring	0.2173.994	0.2173.996	0.2173.972
0083	2	O-ring	0.2173.995	0.2173.997	0.2173.998
0085	2	O-ring	0.2173.914	0.2173.970	0.2173.948
0086	2	O-ring	0.2173.850	0.2173.851	0.2173.989
0087	2	O-ring	0.2173.933	0.2173.924	0.2173.903
O-ring kit EPDM			3.01881.12	3.01882.12	3.01883.12
0082	2	O-ring	0.2173.061	0.2173.206	0.2173.102
0083	2	O-ring	0.2173.088	0.2173.093	0.2173.352
0085	2	O-ring	0.2173.255	0.2173.242	0.2173.202
0086	2	O-ring	0.2173.058	0.2173.067	0.2173.216
0087	2	O-ring	0.2173.054	0.2173.064	0.2173.210
O-ring kit CHEMRAZ®			3.01881.13	3.01882.13	3.01883.13
0082	2	O-ring	0.2173.745	0.2173.747	0.2173.750
0083	2	O-ring	0.2173.746	0.2173.748	0.2173.751
0085	2	O-ring	0.2173.735	0.2173.749	0.2173.723
0086	2	O-ring	0.2173.752	0.2173.754	0.2173.756
0087	2	O-ring	0.2173.753	0.2173.755	0.2173.719
* O-ring kit KALREZ®			3.01881.14	3.01882.14	3.01883.14
0082	2	O-ring	0.2173.636	0.2173.638	0.2173.641
0083	2	O-ring	0.2173.637	0.2173.639	0.2173.642
0085	2	O-ring	0.2173.615	0.2173.640	0.2173.606
0086	2	O-ring	0.2173.643	0.2173.645	0.2173.647
0087	2	O-ring	0.2173.644	0.2173.646	0.2173.602
O-ring kit FPM-FDA			3.01881.20	3.01882.20	3.01883.20
0082	2	O-ring	0.2174.956	0.2174.876	0.2174.957
0083	2	O-ring	0.2174.898	0.2174.877	0.2174.958
0085	2	O-ring	0.2174.919	0.2174.960	0.2174.869
0086	2	O-ring	0.2174.962	0.2174.964	0.2174.987
0087	2	O-ring	0.2173.886	0.2174.981	0.2174.882
O-ring kit EPDM-FDA			3.01881.15	3.01882.15	3.01883.15
0082	2	O-ring	0.2173.511	0.2173.520	0.2173.529
0083	2	O-ring	0.2173.512	0.2173.521	0.2173.530
0085	2	O-ring	0.2173.513	0.2173.522	0.2173.531
0086	2	O-ring	0.2173.514	0.2173.523	0.2173.532
0087	2	O-ring	0.2173.515	0.2173.524	0.2173.533

* Kalrez is a registered trademark of DuPont Performance Elastomers.

Pos.	Nos./ pump	Description	TW2	TW3	TW4
O-ring kit EPDM-FDA, USP Class VI, 3-A, AFO			3.01881.17	3.01882.17	3.01883.17
0082	2	O-ring	0.2174.007	0.2174.013	0.2174.019
0083	2	O-ring	0.2174.008	0.2174.014	0.2174.020
0085	2	O-ring	0.2174.033	0.2174.036	0.2174.039
0086	2	O-ring	0.2174.042	0.2174.044	0.2174.046
0087	2	O-ring	0.2174.043	0.2174.045	0.2174.047
		Certificate			
O-ring kit FPM-FDA, USP Class VI, 3-A, AFO			3.01881.18	3.01882.18	3.01883.18
0082	2	O-ring	0.2174.009	0.2174.015	0.2174.021
0083	2	O-ring	0.2174.010	0.2174.016	0.2174.022
0085	2	O-ring	0.2174.034	0.2174.037	0.2174.040
0086	2	O-ring	0.2174.048	0.2174.050	0.2174.052
0087	2	O-ring	0.2174.049	0.2174.051	0.2174.053
		Certificate			
O-ring kit Perfluor-FDA, USP Class VI, 3-A, AFO			3.01881.19	3.01882.19	3.01883.19
0082	2	O-ring	0.2174.011	0.2174.017	0.2174.023
0083	2	O-ring	0.2174.012	0.2174.018	0.2174.024
0085	2	O-ring	0.2174.035	0.2174.038	0.2174.041
0086	2	O-ring	0.2174.054	0.2174.056	0.2174.058
0087	2	O-ring	0.2174.055	0.2174.057	0.2174.059
		Certificate			

9.0 Single O-ring seal and double O-ring seal

9.1 General information

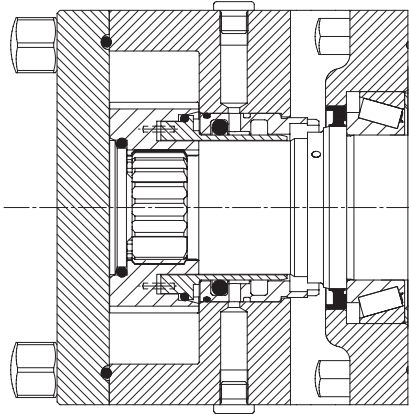

Single O-ring seal

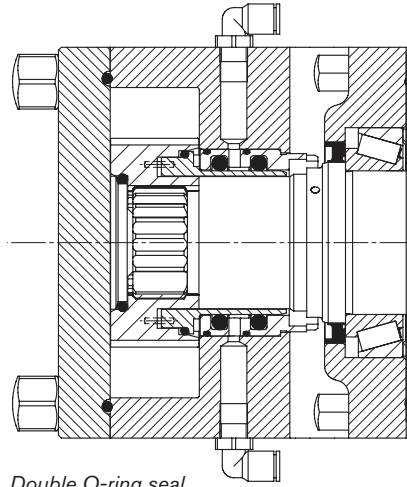

Double O-ring seal

Seal information

- Removable O-ring holder containing the O-ring(s) is fixed in the rotor case by means of pin and slot
- Rotating shaft sleeve is locked in the rotor by means of pins and slot
- Seal face on the shaft sleeve coated with tungsten carbide
- Suitable for both directions of rotation
- Double O-ring arrangement quenched or flushed, pressurized or un-pressurized

Technical data

Materials of O-rings:

Fluorocarbon FPM (Fluoroelastomer)
FPM-FDA (V1 i.e. certified food quality)
EPDM (E)
EPDM-FDA (E1 i.e. certified food quality)
Perfluor Chemraz® (C)
* Perfluor Kalrez® (K)

The minimum required hardness is 80 shore A and recommended hardness is 90 shore A.

Recommended pump speed: TW1 – 300 rpm
TW2 – 190 rpm
TW3 – 150 rpm
TW4 – 110 rpm

Temperature:

Up to the temperature limit of the pump

Maximum pressure:

Up to the operating pressure limit of the pump

Maximum pressure of quench/flushing medium:

16 bar

Pressurised seal:

The pressure of quench/flush medium should be 0.5 bar higher than the process pressure

Unpressurised seal:

Pressure is lower than or equal to the process pressure

Recommended circumf. speed:

Less than 0.5 m/s

* Kalrez is a registered trademark of DuPont Performance Elastomers.

9.2 Machined parts – Seal assemblies and flush covers

Pos.	Description	Europe		USA	Pump			
		DIN	W.nr.		TW1	TW2	TW3	TW4
0130	Shaft sleeve	EN 10088-3	1.4401	AISI 316	X	X	X	X
0097	Support ring	EN 10088-3	1.4401	AISI 316	X	X	X	X

Reference catalogue : *Stahlschlüssel 2001 (steel page 250 – 256 / stainless steel page 492 – 494)*

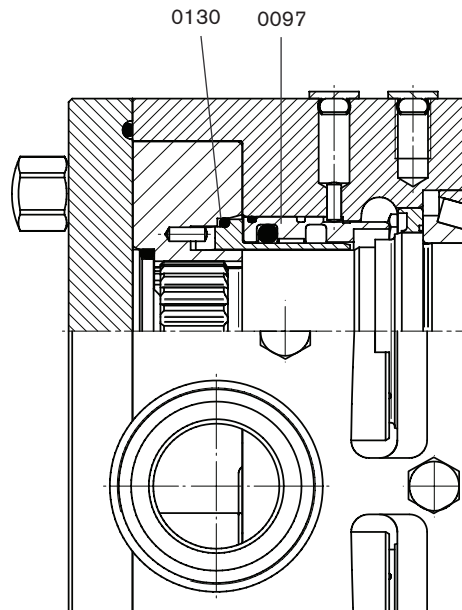

9.3 Seal options

9.3.1 Single O-ring seal

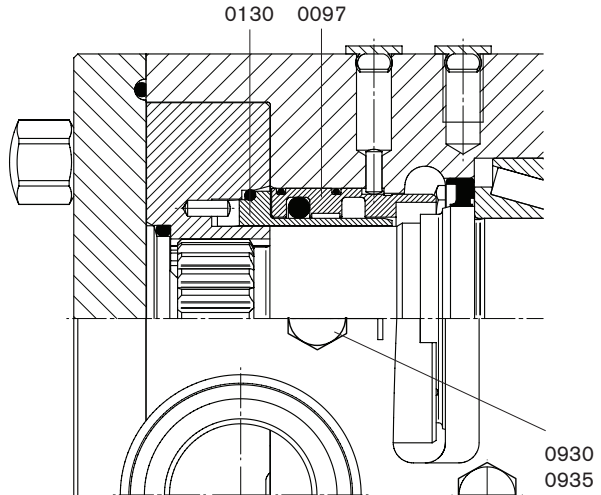
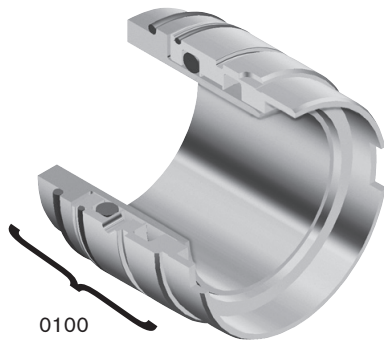

Pos.	Nos./pump	Description	TW1	TW2	TW3	TW4
0097	2	Support ring	3.94813.11	3.94814.11	3.94815.11	3.94816.11
0130	2	Shaft sleeve	3.94817.11	3.94818.11	3.94819.11	3.94820.11
0930	4	Plug	0.0625.061	0.0625.061	0.0625.061	0.0625.061
0935	4	Sealing ring	4A3483.113	4A3483.113	4A3483.113	4A3483.113
	1	Tool for disassembly O-ring seal	3.94998.11	-	-	-

O-ring kit for single O-ring seal, see 9.4.1



Tool for disassembly O-ring seal,
only for TW1

9.3.2 Double O-ring seal

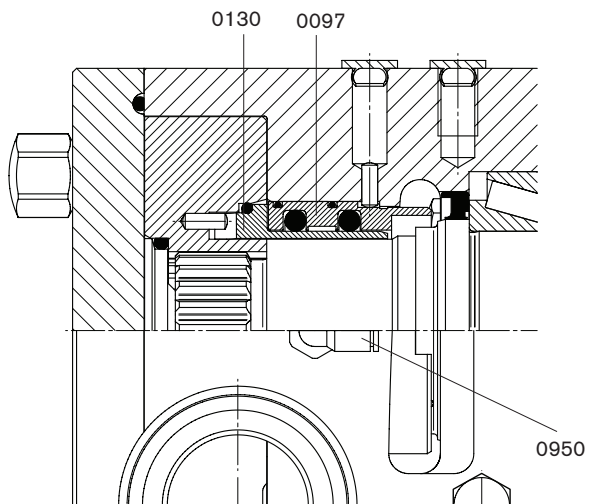
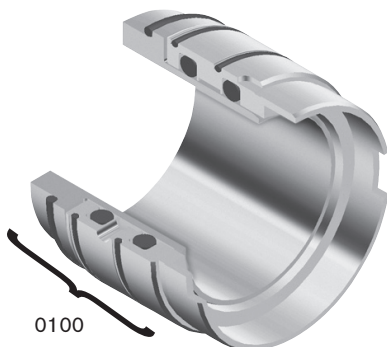

Pos.	Nos./pump	Description	TW1	TW2	TW3	TW4
0097	2	Support ring	3.94813.11	3.94814.11	3.94815.11	3.94816.11
0130	2	Shaft sleeve	3.94817.11	3.94818.11	3.94819.11	3.94820.11
0950	4	Male stud elbow	3.94983.11	3.94983.11	3.94983.11	3.94983.11
	1	Tool for disassembly O-ring seal	3.94998.11	-	-	-

O-ring kit for double O-ring seal, see 9.4.2

9.4 O-ring kits

9.4.1 O-ring kit for single O-ring seal

Note: Only FDA O-rings are approved for food applications

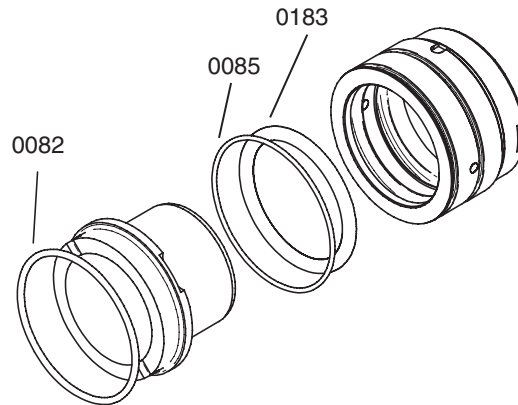

Pos.	Nos./pump	Description	TW1	TW2	TW3	TW4
Kit for FPM O-rings			3.01899.11	3.01900.11	3.01901.11	3.01902.11
0082	2	O-ring	0.2173.992	0.2173.994	0.2173.996	0.2173.972
0085	2	O-ring	0.2173.993	0.2173.914	0.2173.970	0.2173.948
0183	2	O-ring	0.2173.854	0.2173.855	0.2173.968	0.2173.856
Kit for EPDM O-rings			3.01899.12	3.01900.12	3.01901.12	3.01902.12
0082	2	O-ring	0.2173.048	0.2173.061	0.2173.206	0.2173.102
0085	2	O-ring	0.2173.241	0.2173.255	0.2173.242	0.2173.202
0183	2	O-ring	0.2173.079	0.2173.140	0.2173.145	0.2173.153
Kit for CHEMRAZ® O-rings			3.01899.13	3.01900.13	3.01901.13	3.01902.13
0082	2	O-ring	0.2173.742	0.2173.745	0.2173.747	0.2173.750
0085	2	O-ring	0.2173.744	0.2173.735	0.2173.749	0.2173.723
0183	2	O-ring	0.2173.760	0.2173.761	0.2173.730	0.2173.762
* Kit for KALREZ® O-rings			3.01899.14	3.01900.14	3.01901.14	3.01902.14
0082	2	O-ring	0.2173.633	0.2173.636	0.2173.638	0.2173.641
0085	2	O-ring	0.2173.635	0.2173.615	0.2173.640	0.2173.606
0183	2	O-ring	0.2173.651	0.2173.652	0.2173.626	0.2173.653
Kit for FPM-FDA O-rings			3.01899.18	3.01900.18	3.01901.18	3.01902.18
0082	2	O-ring	0.2174.932	0.2174.956	0.2174.876	0.2174.957
0085	2	O-ring	0.2174.959	0.2174.919	0.2174.960	0.2174.869
0183	2	O-ring	0.2173.988	0.2174.999	0.2174.891	0.2174.900
Kit for EPDM-FDA O-rings			3.01899.15	3.01900.15	3.01901.15	3.01902.15
0082	2	O-ring	0.2173.504	0.2173.511	0.2173.520	0.2173.529
0085	2	O-ring	0.2173.506	0.2173.513	0.2173.522	0.2173.531
0183	2	O-ring	0.2173.507	0.2173.516	0.2173.525	0.2173.534

* Kalrez is a registered trademark of DuPont Performance Elastomers.

9.4.2 O-ring kit for double O-ring seal

Note: Only FDA O-rings are approved for food applications

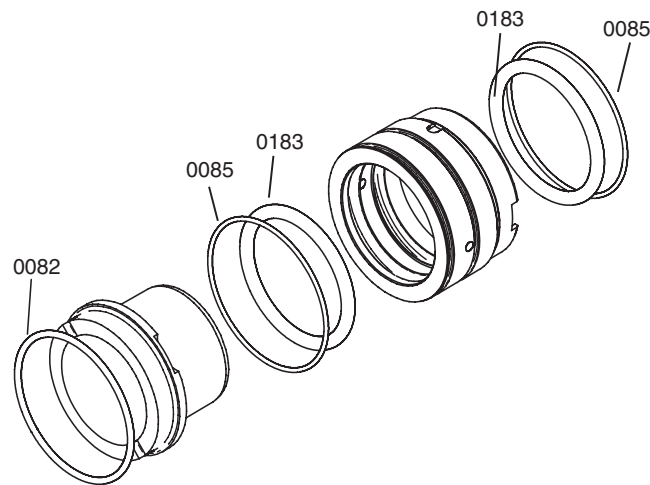

Pos.	Nos./pump	Description	TW1	TW2	TW3	TW4
Kit for FPM O-rings			3.01903.11	3.01904.11	3.01905.11	3.01906.11
0082	2	O-ring	0.2173.992	0.2173.994	0.2173.996	0.2173.972
0085	4	O-ring	0.2173.993	0.2173.914	0.2173.970	0.2173.948
0183	4	O-ring	0.2173.854	0.2173.855	0.2173.968	0.2173.856
Kit for EPDM O-rings			3.01903.12	3.01904.12	3.01905.12	3.01906.12
0082	2	O-ring	0.2173.048	0.2173.061	0.2173.206	0.2173.102
0085	4	O-ring	0.2173.241	0.2173.255	0.2173.242	0.2173.202
0183	4	O-ring	0.2173.079	0.2173.140	0.2173.145	0.2173.153
Kit for CHEMRAZ® O-rings			3.01903.13	3.01904.13	3.01905.13	3.01906.13
0082	2	O-ring	0.2173.742	0.2173.745	0.2173.747	0.2173.750
0085	4	O-ring	0.2173.744	0.2173.735	0.2173.749	0.2173.723
0183	4	O-ring	0.2173.760	0.2173.761	0.2173.730	0.2173.762
* Kit for KALREZ® O-rings			3.01903.14	3.01904.14	3.01905.14	3.01906.14
0082	2	O-ring	0.2173.633	0.2173.636	0.2173.638	0.2173.641
0085	4	O-ring	0.2173.635	0.2173.615	0.2173.640	0.2173.606
0183	4	O-ring	0.2173.651	0.2173.652	0.2173.626	0.2173.653
Kit for FPM-FDA O-rings			3.01903.18	3.01904.18	3.01905.18	3.01906.18
0082	2	O-ring	0.2174.932	0.2174.956	0.2174.876	0.2174.957
0085	4	O-ring	0.2174.959	0.2174.919	0.2174.960	0.2174.869
0183	4	O-ring	0.2174.988	0.2174.999	0.2174.891	0.2174.900
Kit for EPDM-FDA O-rings			3.01899.15	3.01900.15	3.01901.15	3.01902.15
0082	2	O-ring	0.2173.504	0.2173.511	0.2173.520	0.2173.529
0085	4	O-ring	0.2173.506	0.2173.513	0.2173.522	0.2173.531
0183	4	O-ring	0.2173.507	0.2173.516	0.2173.525	0.2173.534

* Kalrez is a registered trademark of DuPont Performance Elastomers.

10.0 Quench and Flush connections

Several connection types for circulation of quench or flush on the shaft sealing are possible according to Seal plans 52, 53 and 54.

These connections are applied on TopWing with single mechanical seal, double mechanical seal and O-ring seal types with quench or flush options.

The shaft seals have separate inlet and outlet connections:

- F1 and F2 for the first shaft seal.
- F3 and F4 for the second shaft seal.

They can be connected parallel or serial wise. The different schemes you can find on the figures below.

Circulation happens by pressure difference or thermosyphon working (i.e. difference in temperature of the barrier liquid). Direction of flow is reversible but to facilitate venting, we advise to bring the outlet on top level.

Maximum differential pressure over seal faces (pressure of quench/flush medium):

- **Single mechanical seal**
The maximum pressure of the quench/flush medium is 0.5 bar due to the limitations of the applied lip seal.
- **Double mechanical seal, pressurised**
The barrier liquid should have a pressure of at least 0.5 bar higher than the differential pressure of the pump.
- **O-ring seal**
The maximum allowable pressure of the quench/flush medium is the same as the maximum allowable pressure of the pump. See section 2.2.

If you need more information, please contact your supplier.

10.1 Seal plans

10.1.1 Pump connections in horizontal position

A) Seal plan 54 (circulation) or plan 62 (throughflow)

Use a pressurised external barrier fluid reservoir or system to clean fluid to the seal chamber.

Circulation by an external pressure system or pump.

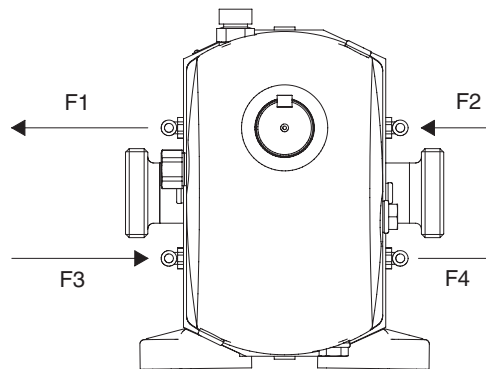

Section A-A

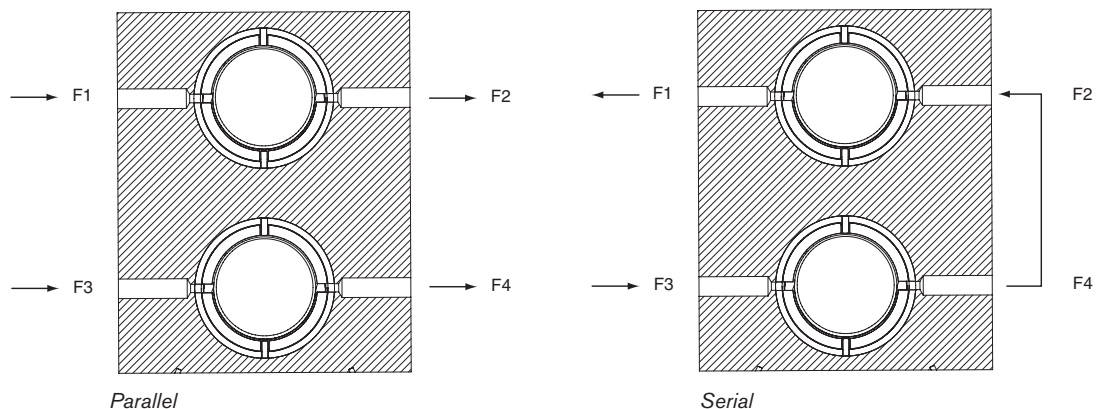
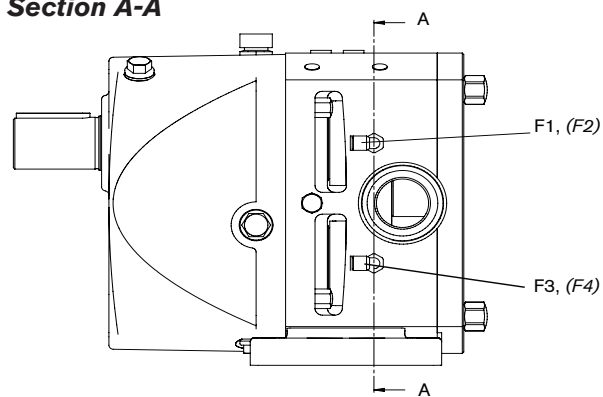

Parallel

Serial

B) Seal plan 52 – Unpressurised double seal

Use an external reservoir to provide unpressurised buffer fluid

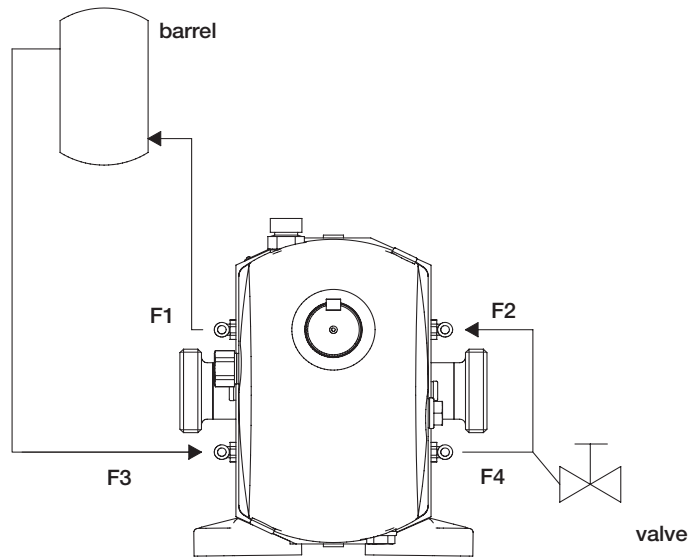

Section A-A

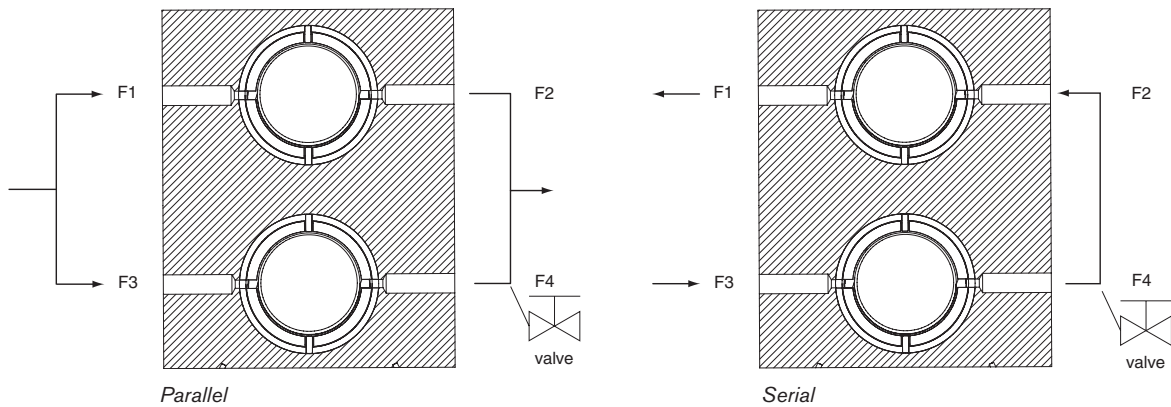
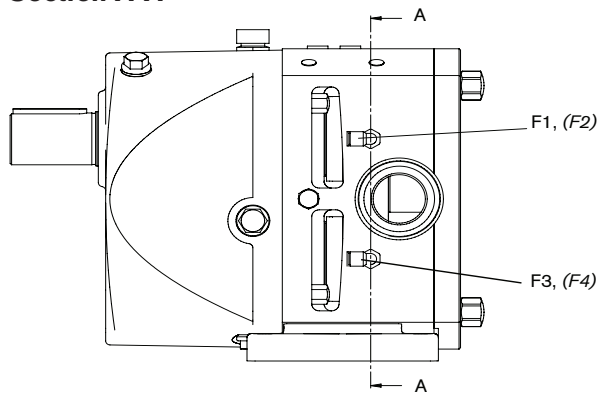

C) Seal plan 53 – Pressurised double seal

Use a pressurised external reservoir to supply clean fluid to the seal chamber.

Reservoir pressure is greater than the in the sealing chamber process pressure.

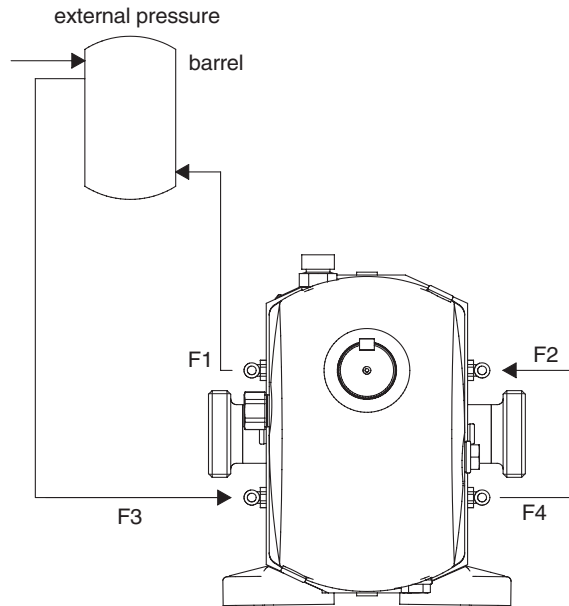

Section A-A

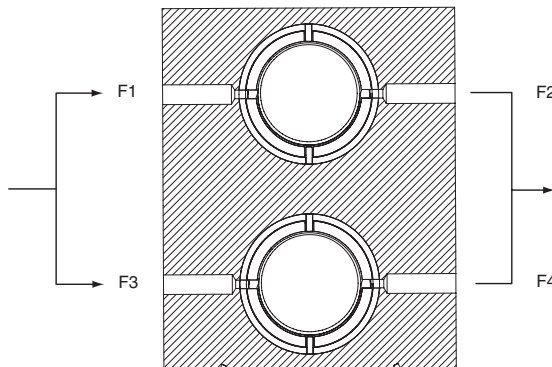
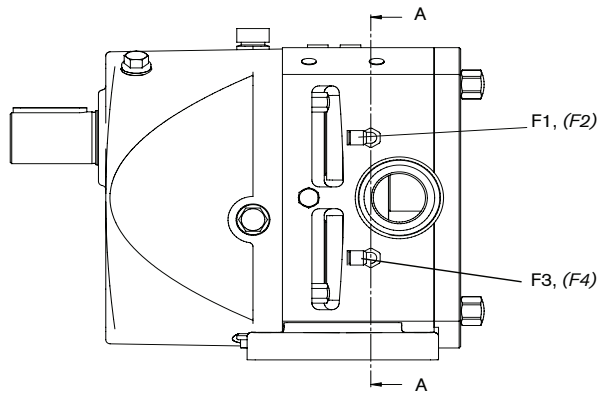

Parallel

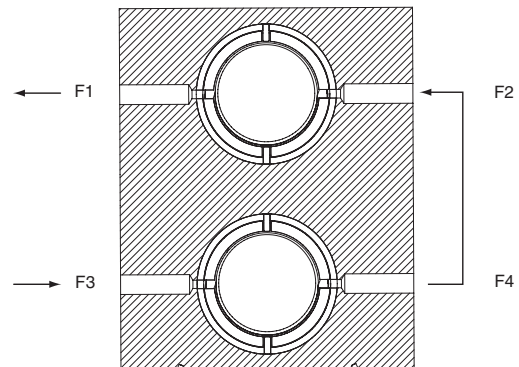

Serial

10.1.2 Pump connections in vertical position

A) Seal plan 54 (circulation) or plan 62 (throughflow)

Use a pressurised external barrier fluid reservoir or system to clean fluid to the seal chamber.

Circulation by an external pressure system or pump.

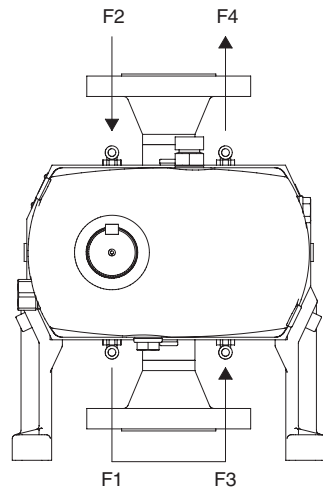

Section A-A

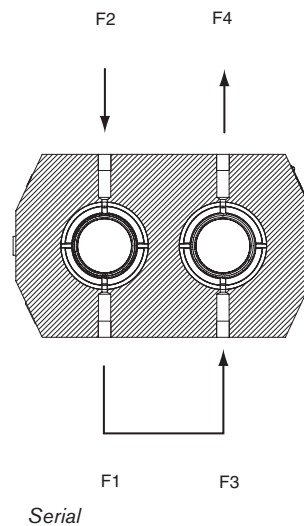
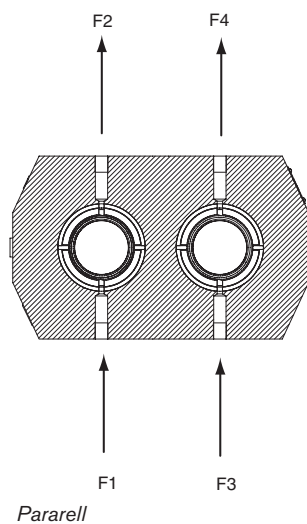
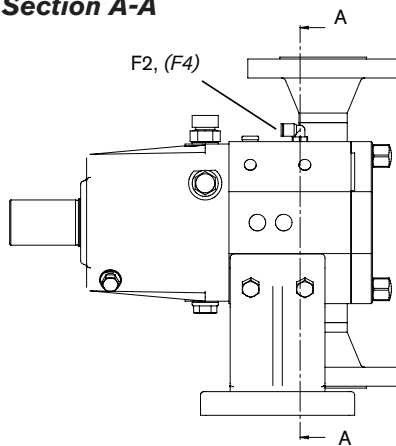

B) Seal plan 52 – Unpressurised double seal

Use an external reservoir to provide unpressurised buffer fluid

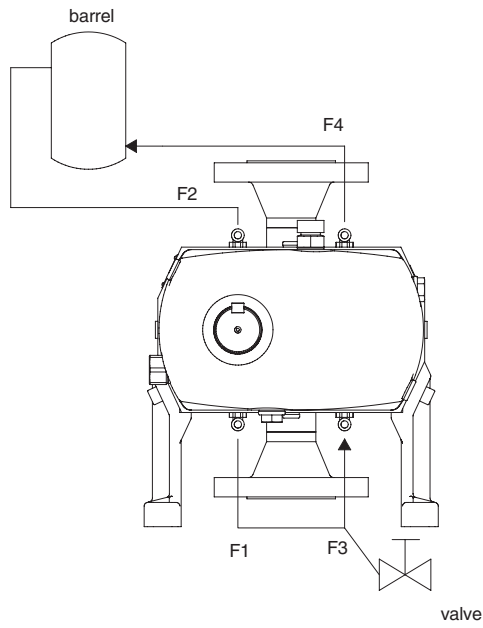

Section A-A

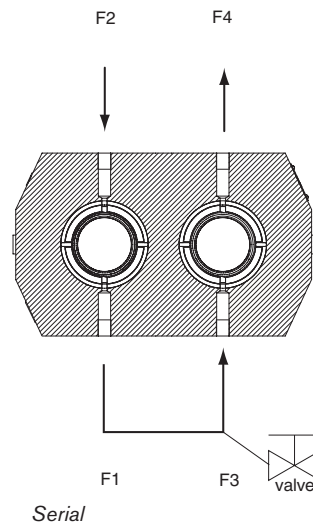
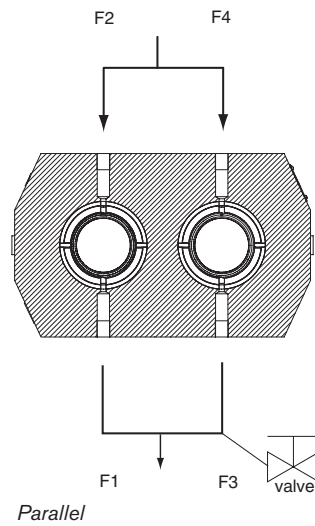
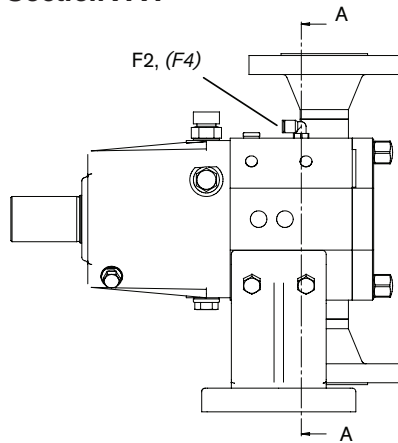

C) Seal plan 53 – Pressurised double seal

Use a pressurised external barrier fluid reservoir to supply clean fluid to the seal chamber.

Reservoir pressure is greater than the in the sealing chamber process pressure.

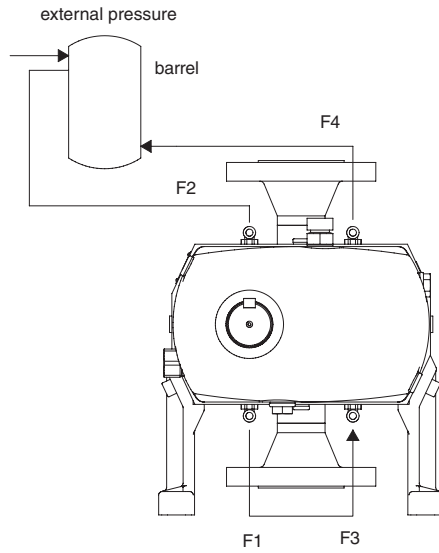

Section A-A

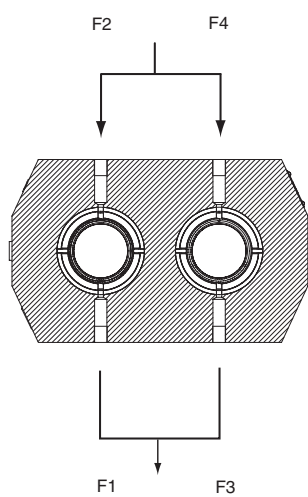
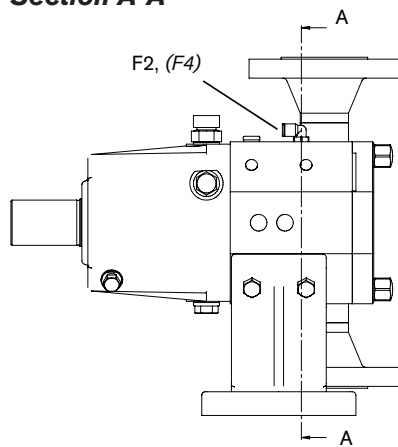

Parallel

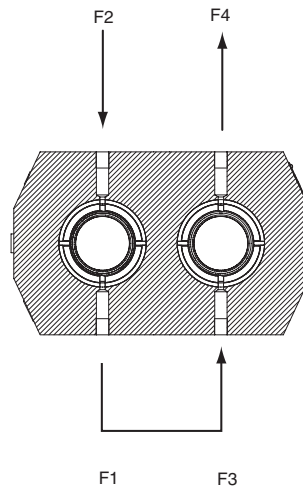

Serial

11.0 Valves and jackets

11.1 Heating and cooling jackets

All TopWing models can be supplied with pump covers with channels for heating or cooling.

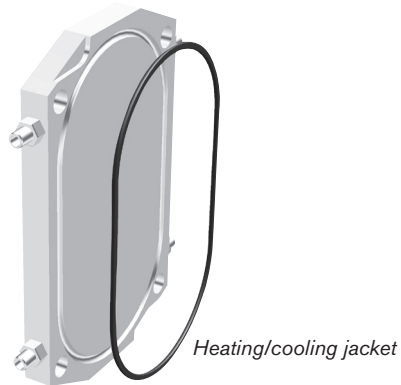

The reason for having this possibility is mainly used for bringing the medium inside the rotor case on temperature before starting up the pump. This option is not meant to heat, cool or maintain the temperature of the pumped medium in the process. The pre-heating or cooling of the pump cover should be integrated in the heating or cooling system of the installation.

The pump cover with or without safety relief valve for heating/cooling is provided with two holes drilled straight through the cover. The heat is transferred to the rotor case via the contact faces between cover and rotor case.

The heating/cooling channels in the pump cover together with the flush holes of the shaft seal are positioned in such a way that the required thermal effects on the built-on safety relief valve, rotor case and shaft seal are the best.

The pressure rating at the ports of the pump cover for heating/cooling is 10 bar and should not be exceeded without contacting your supplier for advice.

For start-up and shut-down procedures where heating/cooling devices are employed, the heating/cooling medium should circulate 20-45 minutes before start-up and/or shut-down. When CIP/SIP cycle is employed as a part of the process, the heating/cooling medium should continue to circulate during the cleaning/sterilizing process.

11.2 Built-on safety relief valves

TopWing pumps can be supplied with following types of built-on safety relief valves. For the TW4 models only the air loaded version with CIP/SIP valve function can be supplied.

	TW1	TW2	TW3	TW4
Spring loaded	X	X	X	-
Spring loaded - air lifted for CIP, SIP function	X	X	X	-
Air loaded - air lifted for process adjustment with CIP, SIP function	X	X	X	X

Following pressure limitations are applicable for TopWing pumps

Pump type	max differential pressure [bar]	max operating pressure [bar]
TW1/0041	15	18
TW1/0082	7	10
TW2/0171	15	18
TW2/0343	7	10
TW3/0537	15	18
TW3/1100	7	10
TW4/1629	15	18
TW4/3257	7	10

11.2.1 General description

Significant for all SPX safety relief valves is that the valve head is built directly into the pump cover. In this way the valve is of the highest hygienic design and easy to clean or check. The head has been designed to maximize the flow passage section and to minimize pressure losses as well as allow particles to pass through. When the valve head is opening, it creates a short cut between discharge and suction side of the pump. On the valves equipped with air-lift function the valve head can be opened to create a by-pass to reach the necessary flow-passage for CIP or SIP cleaning.

The valve head is covering part of the discharge side as well as the suction side of the pump. It is also covering most of the front face of the rotors. The pressure distribution in this area is depending on the properties of the pumped media. The differential pressure on the pump is influencing the load that is acting on the valve head. The set value of the spring or air pressure is balancing the valve head. The properties of the pumped media, the design of the application as well as the process influences the load acting on the valve head. These are the main reasons why the valve setting should not be done in the factory. The opening pressure of the safety relief valve is set to 0 bar from factory. The setting of the valve should be carried out on site under proposed duty conditions for which the pump and valve were selected.

When the differential pressure of the pump becomes higher than the valve settings, the valve head will open. Due to the large size of the valve head, the full capacity of the pump can pass through the valve from the discharge back to the suction side. With the correct setting it is not possible to overpressure the pump under no circumstances.

If the pump is working against a closed discharge valve the medium circulates inside the pump via the relief valve. The hydraulic power and the friction losses are transformed to thermal energy and the temperature of this relatively small volume of circulating fluid will rise if the pump continues to operate for an extended period of time. In severe cases this may result in temperatures exceeding the operating limits of the pump or in vaporization of the fluid, both of which should be avoided. For these reasons, the valve should only be used as a safety relief valve and not as flow control valve.

When the valve is activated an unforeseen operating condition has occurred. The reason for the system pressure increase should be investigated and corrected, as continuous operation of the pump with the valve open is not allowable and may cause severe damage to the pump.

Under no circumstances attempt should be made to dismantle a safety relief valve when the spring pressure is not relieved, when it is still connected to a pressurized air supply or is mounted on the pump while the pump is operating. Serious personal injury or pump damage may occur.



11.2.2 Safety relief valve - Spring Loaded

11.2.2.1 Spring Loaded

Fig. 1 and 2 are showing the design of the spring loaded safety relief valve. The valve head (A) is subjected to the fluid pressure in the rotor case on one side and by spring force on the other side. The spring is acting directly on the valve head.

By turning the spring adjusting screw (B) the compression of the spring is modified and the opening pressure of the safety relief valve can be adjusted.

To turn the spring adjusting screw (B), the retainer tool delivered with the pump must be used.

Fig. 1 shows the safety relief valve completely closed. The valve head (A) is in line with the front face of the pump cover. The valve has been adjusted by compressing the spring via the spring adjusting screw (B).

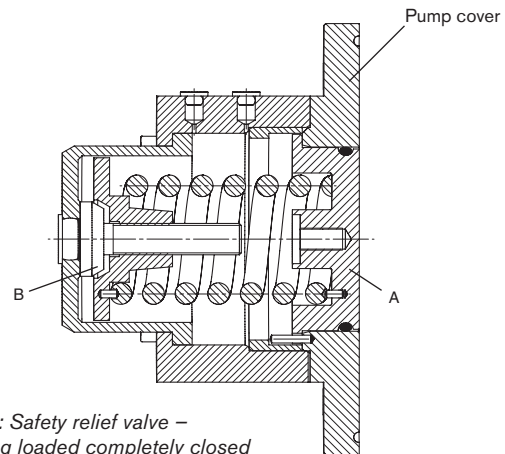

Fig 1: Safety relief valve –
Spring loaded completely closed

Fig. 2 shows the valve partly opened. The medium pressure inside the rotor case has forced the valve head (A) to the left against the force of the spring.

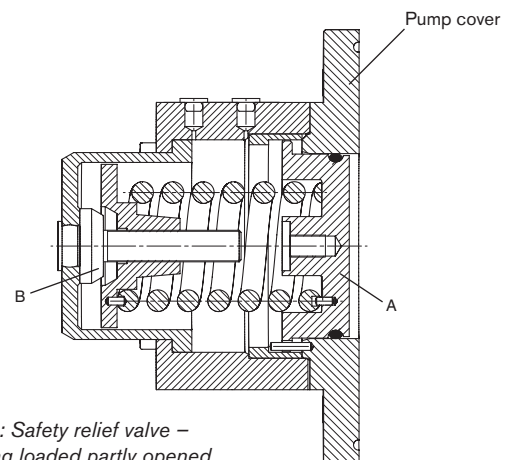

Fig 2: Safety relief valve –
Spring loaded partly opened

11.2.2.2 Spring loaded completely opened

Fig. 3 is showing the design of the spring loaded safety relief valve completely opened.

The medium pressure inside the rotor case has forced the valve head (A) completely to the left against the force of the spring.

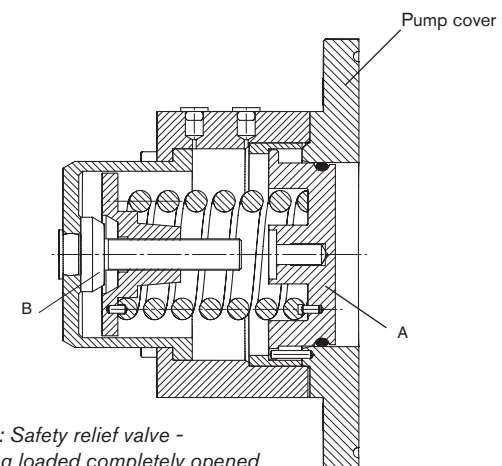

Fig 3: Safety relief valve -
Spring loaded completely opened

11.2.3 Safety relief valve - Spring loaded - air lifted

11.2.3.1 Spring loaded - air lifted

Fig. 4 and 5 are showing the design of the spring loaded - air lifted safety relief valve. The valve head (A) is subjected to the fluid pressure in the rotor case on one side and by spring force on the other side. The spring is not acting directly on the valve head (A) but via piston (C) and spacer sleeve (D).

By turning the spring adjusting screw (B) the compression of the spring is modified and the opening pressure of the safety relief valve can be adjusted. To turn the spring adjusting screw (B), the retainer tool delivered with the pump must be used.

Fig. 4 shows the safety relief valve completely closed. The valve head (A) is in line with the front face of the pump cover and the CIP/SIP valve cylinder is completely relieved.

The setting pressure of the valve has been adjusted by compressing the spring via the spring adjusting screw (B).

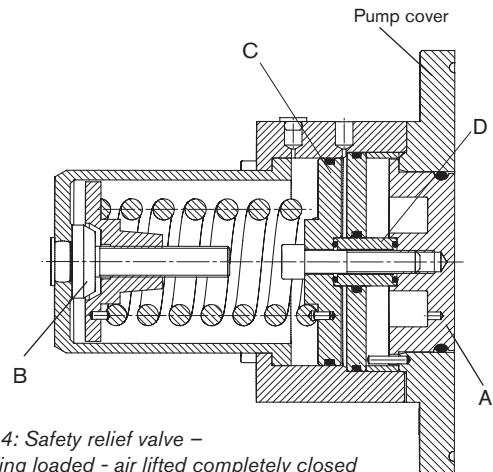

Fig 4: Safety relief valve –
Spring loaded - air lifted completely closed

Fig. 5 shows the valve partly opened. The medium pressure inside the rotor case has forced the valve head (A) to the left against the force of the spring via the distance sleeve and the CIP/SIP piston valve.

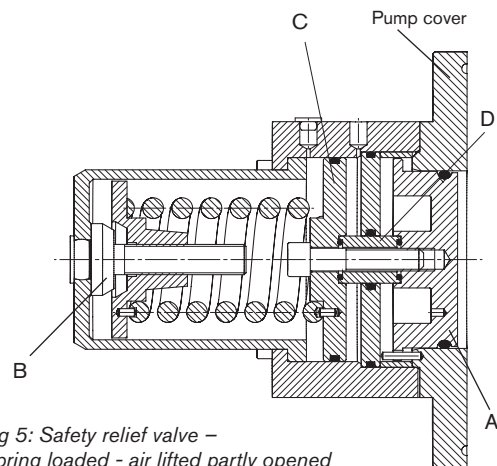

Fig 5: Safety relief valve –
Spring loaded - air lifted partly opened

11.2.3.2 Spring loaded - air lifted with CIP/SIP valve function

Fig. 6 shows the valve completely opened. The pressure inside chamber (ii) has forced the piston (C) and the valve head (A) which is connected to it to the left against the force of the spring.

To operate the CIP/SIP valve function chamber (ii) must be pressurized with 6 bar, which is the normal pressure of air supply systems. This way it is ensured that the valve is opening far enough for CIP/SIP cleaning purposes.

The pressure is acting on the CIP/SIP valve piston (C). By doing that the CIP/SIP valve piston (C) and the valve head (A) which is connected to it via the spacer sleeve (D) will move against the force of the spring.

To resume the safety relief valve function, cylinder (ii) must be completely relieved.

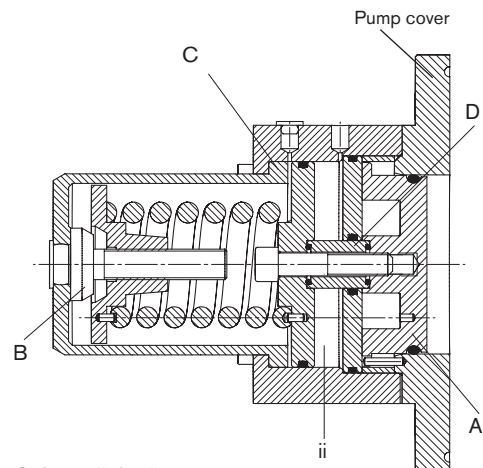

Fig 6: Safety relief valve –
Spring loaded - air lifted with CIP/SIP valve function

11.2.4 Setting and operating – Spring loaded and spring loaded - air lifted

Since the opening pressure of the relief valve is depending on the viscosity of the pumped medium, the setting of the relief valve should be done while the pump is fitted in the installation. To be able to do so there must be a pressure gauge installed as close as possible to the pump discharge port and a valve must be foreseen in the discharge line to adjust the discharge pressure.

To adjust the set-pressure of valve do as follows:

- Remove the plastic plug at the front of the valve
- Use the retainer tool to turn the adjusting screw counter-clockwise until the spring is completely relieved
- Connect the pressure gauge to the discharge line and open the discharge valve completely
- Start the pump
- Use the retainer tool to turn the adjusting screw clockwise until the maximum spring setting is reached (the valve is blocked). While doing this, check on the pressure gauge that the pressure does not rise above the maximum allowable pressure of the pump.
- Close the discharge valve slowly until the desired set-pressure is reached
- Use the retainer tool to turn the adjusting screw of the valve slowly counter-clockwise until the discharge pressure is starting to drop away
- Check the proper setting of the valve by slowly opening and closing the discharge valve. The set-pressure of the relief valve can be increased by turning the adjusting screw clockwise and decreased by turning the adjusting screw counter-clockwise
- After setting the relief valve, open the discharge valve completely

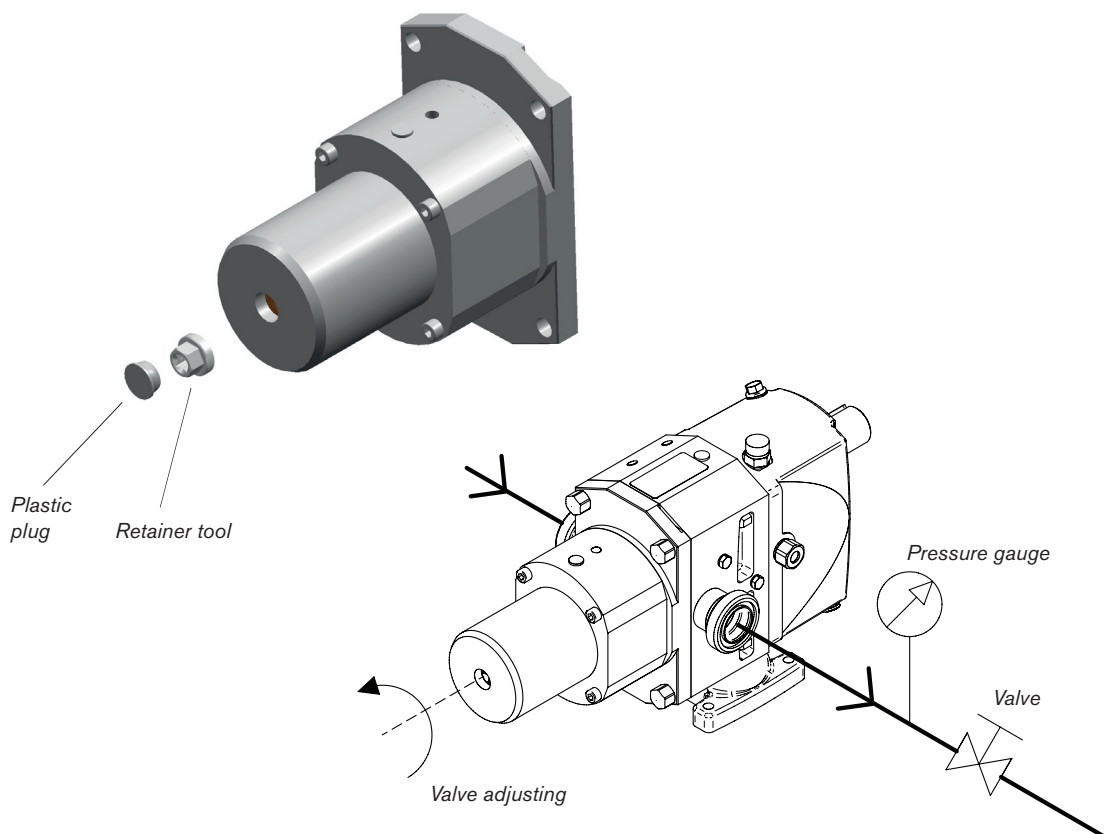

Note: If the valve is not adjusted according to the method described above the correct valve setting cannot be guaranteed and the pump might be damaged because of too high discharge pressure.

If there is no possibility to connect a pressure gauge or there is no discharge valve foreseen in the installation, the valve can be pre-adjusted according to the procedure described below.

- Remove the plastic plug at the front of the valve
- Use the retainer tool to turn the adjusting screw counter-clockwise until the spring is completely relieved
- Turn the spring adjusting screw X number of turns clockwise in function of the desired opening pressure (see table below)

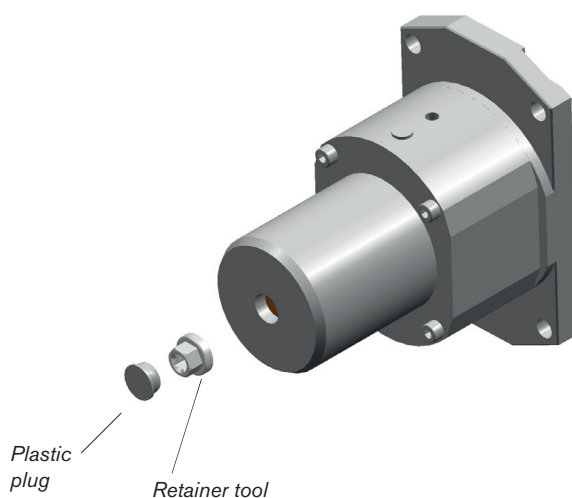

The values in the table are based on the assumption that the suction pressure is between 0.5 and 1 bar absolute. Please note that the values are a rough adjustment.

TW1	
Discharge pressure pd (bar)	Rotate adjusting screw X turns
0	0.0
1	0.6
2	1.3
3	1.9
4	2.6
5	3.2
6	3.9
7	4.5
8	5.2
9	5.8
10	6.5
11	7.1
12	7.8
13	8.4
14	9.0
15	9.7

TW2	
Discharge pressure pd (bar)	Rotate adjusting screw X turns
0	0.0
1	1.4
2	2.8
3	4.2
4	5.6
5	6.9
6	8.3
7	9.7
8	11.1
9	12.5
10	13.9
11	15.3
12	16.7
13	18.0
14	19.4
15	20.8

TW3	
Discharge pressure pd (bar)	Rotate adjusting screw X turns
0	0.0
1	2.7
2	5.3
3	8.0
4	10.6
5	13.3
6	16.0
7	18.6
8	21.3
9	23.9
10	26.6
11	29.3
12	31.9
13	34.6
14	37.2
15	39.9

11.2.5 Safety relief valve - air loaded - air lifted

11.2.5.1 Air loaded

Fig 7 and 8 are showing the design of the air loaded - air lifted safety relief valve.

The pressure in the control chamber (i) is keeping the valve head in balance with the medium pressure. If the force created by the medium pressure becomes higher than the force created by the control pressure acting on piston (B), the valve head (A) starts to move and the valve opens.

While only part of the valve head (A) is loaded by the discharge pressure, the biggest portion of the valve head (A) is covered by the rotors (front clearances) or loaded by the relatively low suction pressure, the control pressure is working on the full surface of the control piston.

That implies that the control pressure has to be set much lower than the opening pressure of the valve. To give an indication we can state that, depending on the nature of the pumped medium and the suction pressure, the control pressure has to be adjusted to only about half of the opening pressure of the valve.

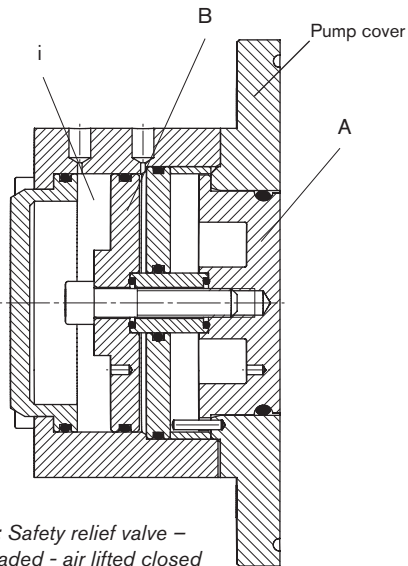

Fig 7: Safety relief valve –
Air loaded - air lifted closed

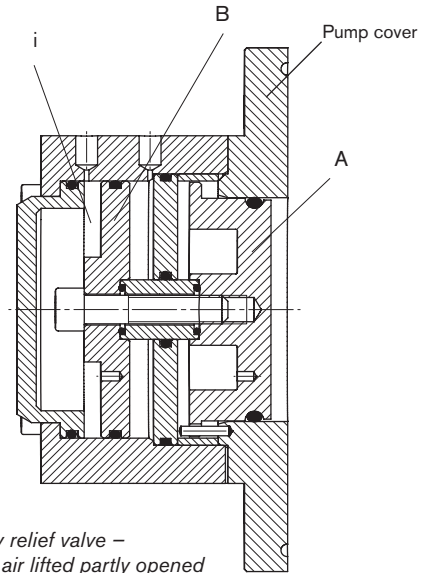

Fig 8: Safety relief valve –
Air loaded - air lifted partly opened

11.2.5.2 Air loaded-air lifted with CIP/SIP valve function

Fig. 9 is showing the design of the air loaded - air lifted safety relief valve with CIP/SIP valve function.

To operate the CIP/SIP valve function chamber (ii) must be pressurized.

The pressure is acting on the rear face of the piston (B). By doing that, valve head (A) and piston (B) which are connected to each other, will move against the force created by the control pressure inside chamber (i).

If the control pressure is maintained during the CIP/SIP valve operation, the pressure needed to open the valve must be about 0.5 bar higher than the control pressure in chamber (i). To resume the safety relief valve function, chamber (ii) must be completely relieved.

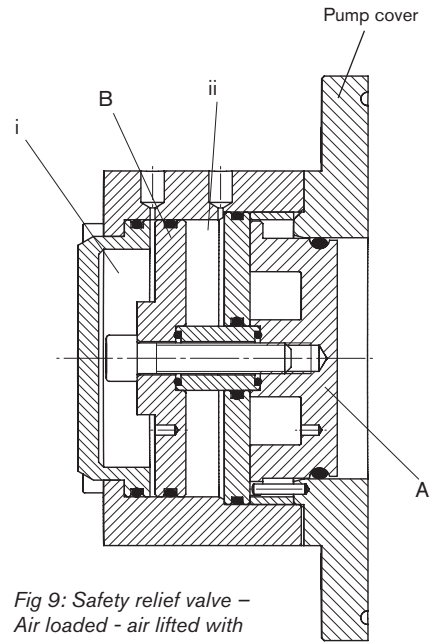
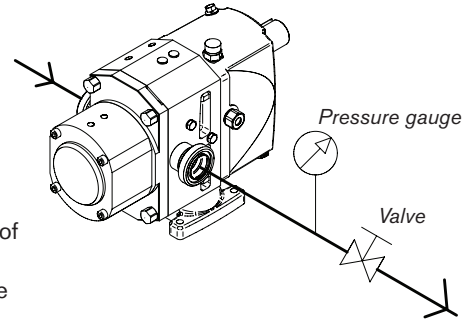

Fig 9: Safety relief valve –
Air loaded - air lifted with
CIP/SIP valve function

11.2.6 Setting and operating – Air loaded - air lifted safety relief valves

To adjust the set-pressure of valve do as follows:

- Make sure that the pressure in the control pressure cylinder and the air lift chamber is completely relieved.
- Connect the pressure gauge to the discharge line and open the discharge valve completely
- Start the pump
- Operate the air adjusting valve to slowly increase the control pressure of the valve until the maximum control pressure is reached. While doing this check that the discharge pressure is not rising above the maximum allowable pressure of the pump
- Close the discharge valve slowly until the desired set-pressure is reached
- Operate the adjusting valve slowly to decrease the control pressure of the valve until the discharge pressure is starting to drop away
- Check the proper setting of the valve by slowly opening and closing the discharge valve. The set-pressure of the relief valve can be increased by increasing the control pressure and decreased by decreasing the control pressure
- After setting the relief valve, open the discharge valve completely



If the valve is not adjusted according to the method described above the correct valve setting cannot be guaranteed and the pump might be damaged because of too high discharge pressure.

If there is no possibility to connect a pressure gauge in the discharge line or there is no discharge valve foreseen in the installation, the valve setting might be approached by adjusting the control pressure to the values indicated in the table below.

Note: Since the control pressure is depending on the nature of the pumped medium the values given in the table below must be interpreted as guidelines.

Opening pressure (bar)	TW1/0041	TW1/0082	TW2/0171	TW2/0343	TW3/0537	TW3/1100	TW4/1629	TW4/3257
	Control pressure (bar)							
1	0.2	0.2	0.4	0.4	0.4	0.4	0.4	0.4
2	0.4	0.4	0.7	0.7	0.7	0.7	0.7	0.7
3	0.6	0.6	1.1	1.1	1.1	1.1	1.1	1.1
4	0.8	0.8	1.4	1.4	1.4	1.4	1.5	1.5
5	1.0	1.0	1.8	1.8	1.8	1.8	1.8	1.8
6	1.2	1.2	2.1	2.1	2.1	2.1	2.2	2.2
7	1.3	1.3	2.5	2.5	2.5	2.5	2.6	2.6
8	1.5	–	2.8	–	2.8	–	2.9	–
9	1.7	–	3.2	–	3.2	–	3.3	–
10	1.9	–	3.6	–	3.5	–	3.7	–
11	2.1	–	3.9	–	3.9	–	4.0	–
12	2.3	–	4.3	–	4.2	–	4.4	–
13	2.5	–	4.6	–	4.6	–	4.7	–
14	2.7	–	5.0	–	4.9	–	5.1	–
15	2.9	–	5.3	–	5.3	–	5.5	–

11.3 Disassembly/Assembly

11.3.1 Spring loaded valves

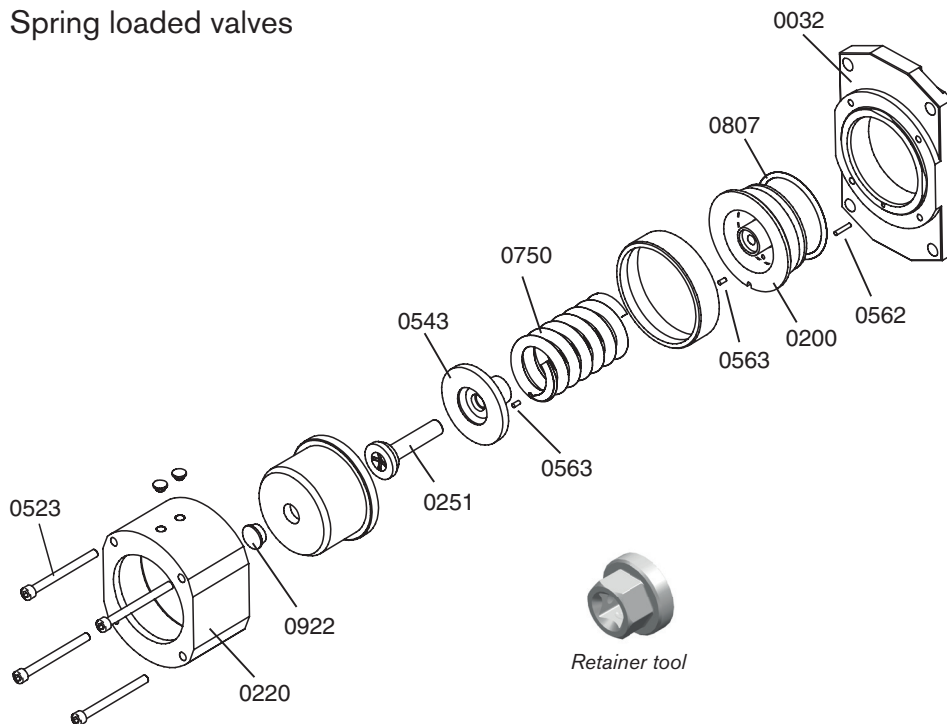

11.3.1.1 Disassembly

1. Remove plastic plug (0922).
2. Release the spring (0750) by turning the spring adjusting screw (0251) counter-clockwise using the retainer tool.

Warning

3. Remove screws (0523) by loosening them all one full turn.

If the cylinder (0220) stays in place (tap slowly with a plastic hammer on the cylinder) the spring (0750) is fully released and the screws can be removed.

If the cylinder does not stay in place, first make sure that the spring will be released.

4. All components can now be removed from the cylinder (0220) and from the pump cover (0032).

11.3.1.2 Assembly

1. Screw the spring adjusting screw (0251) fully into the spring adjusting plate (0543).
2. If disassembled, place the two pins (0563) in the spring adjusting plate (0543) and in the valve head (0200) respectively. Place the pin (0562) in the same way in the pump cover (0032).
3. Place the O-ring (0807) on the outside of the valve head (0200) and push the valve head with O-ring into the pump cover (0032).
4. Put all components in place and tighten the screws (0523).

11.3.2 Spring loaded - air lifted valves

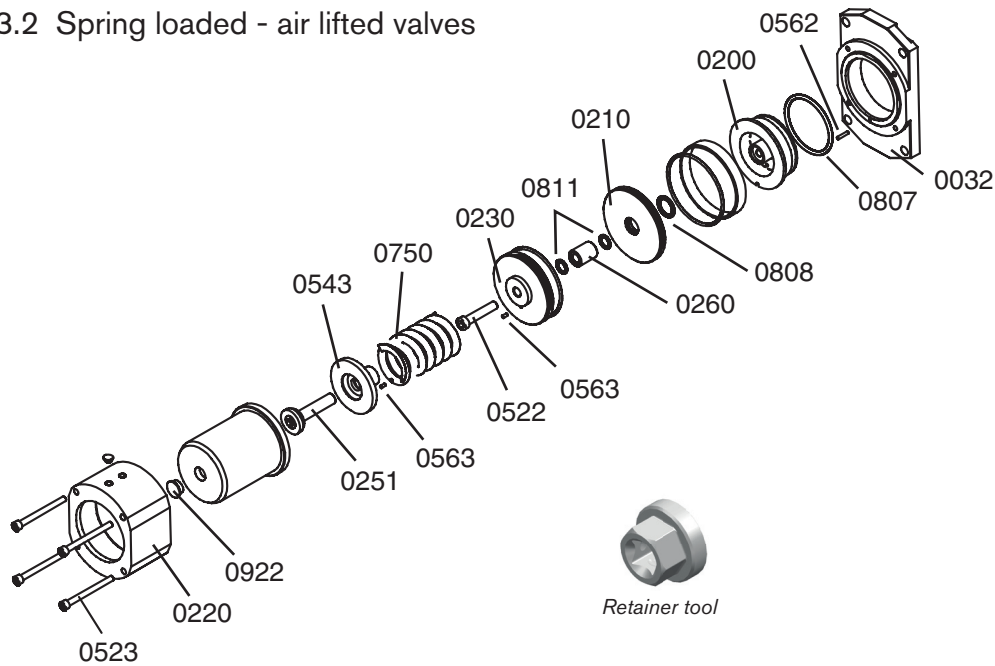

11.3.2.1 Disassembly

1. Remove plastic plug (0922).
2. Release the spring (0750) by turning the spring adjusting screw (0251) counter-clockwise using the retainer tool.

Warning

3. Remove screws (0523) by loosening them all one full turn.

If the cylinder (0220) stays in place (tap slowly with a plastic hammer on the cylinder) the spring (0750) is fully released and the screws can be removed.

If the cylinder does not stay in place, first make sure that the spring will be released.

4. All components can now be removed from the cylinder (0220) and from the pump cover (0032).

11.3.2.2 Assembly

1. Screw the spring adjusting screw (0251) fully into the spring adjusting plate (0543).
2. If disassembled place the two pins (0563) in the spring adjusting plate (0543) and in the piston (0230) respectively. Place the pin (0562) in the same way in the pump cover (0032).
3. Place the piston (0230) together with the valve head (0200) by using the spacer sleeve (0260) with the O-rings (0811). Before tightening the screw (0522) ensure that the baseplate (0210) with O-ring (0808) is placed over the spacer sleeve (0260).
4. Put all components in place and tighten the screws (0523).

11.3.3 Air loaded - air lifted valves

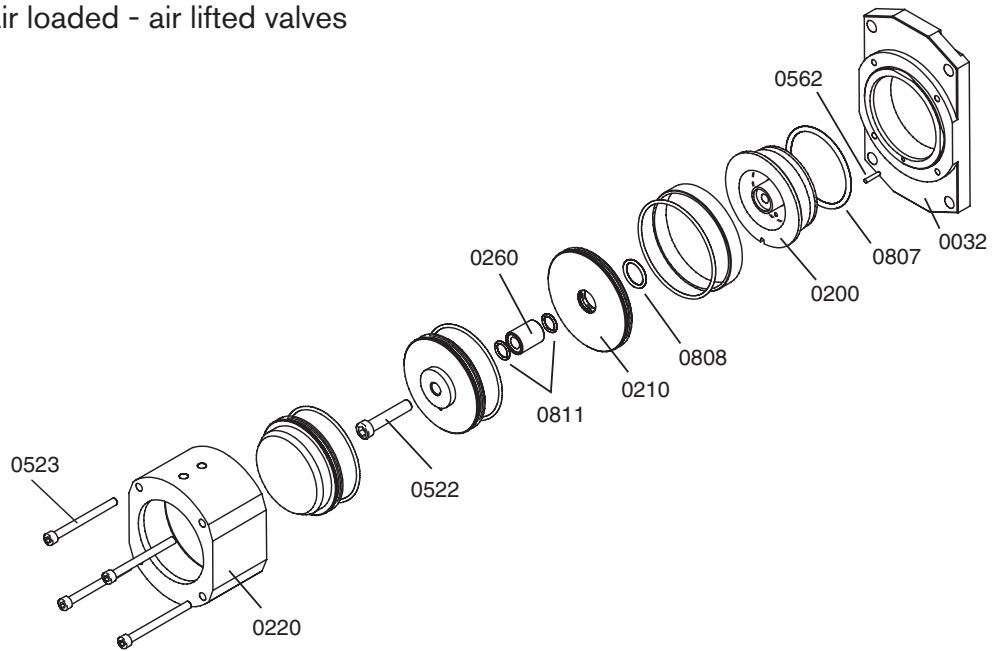

11.3.3.1 Disassembly

1. Remove screws (0523).
2. All parts can now be removed from the cylinder (0220).

11.3.3.2 Assembly

1. If disassembled place the pin (0562) into the pump cover (0032).
2. Screw the piston (0230) together with the valve head (0200) by using the spacer sleeve (0260) with the O-rings (0811). Before tightening the screw (0522) ensure that the baseplate (0210) with O-ring (0808) is placed over the spacer sleeve (0260).
3. Put all components in place and tighten the screws (0523).

11.4 Dimensional drawings and weights

11.4.1 Heating/cooling jackets and Safety relief valves

See next page for the dimensional table

Horizontal mounting

Jacket

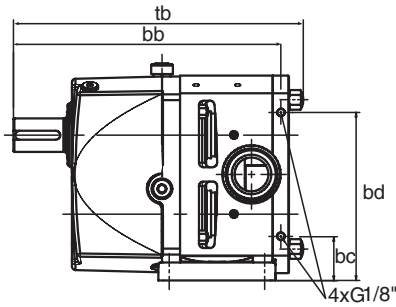

Relief valve – Spring loaded with jacket

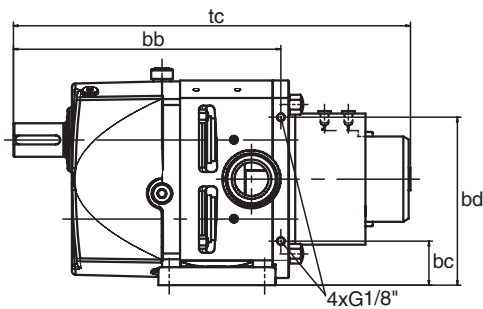

Relief valve – Spring loaded – air lifted with jacket

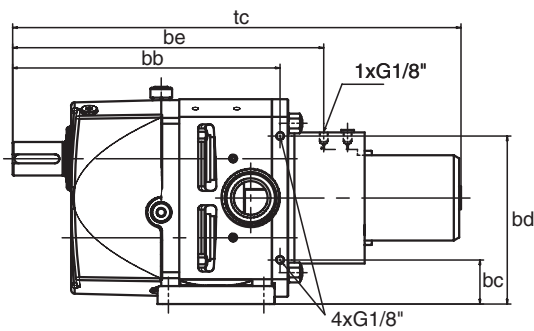

Relief valve – Air loaded – air lifted with jacket

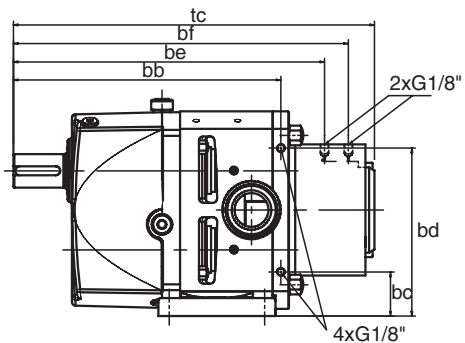

Vertical mounting

Jacket

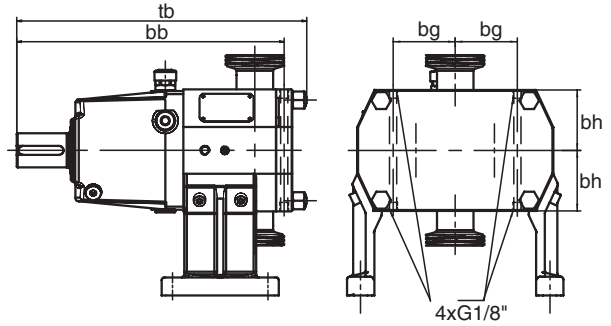

Relief valve – Spring loaded with jacket

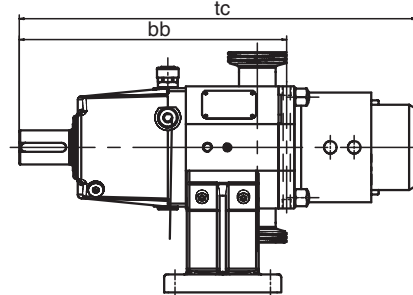

Relief valve – Spring loaded – air lifted with jacket

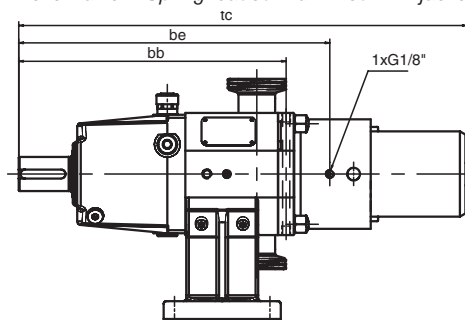

Relief valve – Air loaded – air lifted with jacket

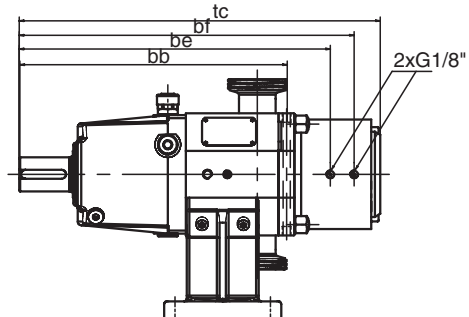

Dimensions - Heating/cooling jackets and safety relief valves

Pump type		bb	bc	bd	be	bf	bg	bh	tb	tc
TW1/0041	jacket	219	40.5	128.5	-	-	44	52	238	-
	spring loaded	218	40.5	128.5	-	-	44	52	-	341
	spring loaded - air lifted	218	40.5	128.5	256.5	-	44	52	-	388
	air loaded - air lifted	218	40.5	128.5	256.5	278	44	52	-	306
TW1/0082	jacket	239	40.5	128.5	-	-	44	52	258	-
	spring loaded	238	40.5	128.5	-	-	44	52	-	361
	spring loaded - air lifted	238	40.5	128.5	276.5	-	44	52	-	408
	air loaded - air lifted	238	40.5	128.5	276.5	292	44	52	-	326
TW2/0171	jacket	298	49	187	-	-	69	68	322	-
	spring loaded	297	49	187	-	-	69	68	-	441
	spring loaded - air lifted	297	49	187	345.5	-	69	68	-	498
	air loaded - air lifted	297	49	187	345.5	372	69	68	-	401
TW2/0343	jacket	329	49	187	-	-	69	68	354	-
	spring loaded	328	49	187	-	-	69	68	-	472
	spring loaded - air lifted	328	49	187	376.5	-	69	68	-	529
	air loaded - air lifted	328	49	187	376.5	403	69	68	-	432
TW3/0537	jacket	378	72	242	-	-	85	91	410	-
	spring loaded	378	72	242	-	-	85	91	-	587
	spring loaded - air lifted	378	72	242	441.5	-	85	91	-	659
	air loaded - air lifted	378	72	242	441.5	476	85	91	-	514
TW3/1100	jacket	423	72	242	-	-	85	91	455	-
	spring loaded	423	72	242	-	-	85	91	-	632
	spring loaded - air lifted	423	72	242	486.5	-	85	91	-	704
	air loaded - air lifted	423	72	242	486.5	521	85	91	-	559
TW4/1629	jacket	520	96	336	-	-	120	126	563	-
	air loaded - air lifted	520	96	336	599	644	120	126	-	694
TW4/3257	jacket	584	96	336	-	-	120	126	627	-
	air loaded - air lifted	584	96	336	663	708	120	126	-	758

All dimensions in mm

11.5 Weights safety relief valve

Pump type	Type of safety relief valve		
	spring loaded	spring loaded - air lifted	air loaded - air lifted
TW1	5	5.5	4.5
TW2	11	12	10
TW3	27	30	25
TW4	-	-	62

All weights in daN, mass is kg.

11.6 Sectional drawings and parts list

11.6.1 Pump cover with safety relief valve spring loaded

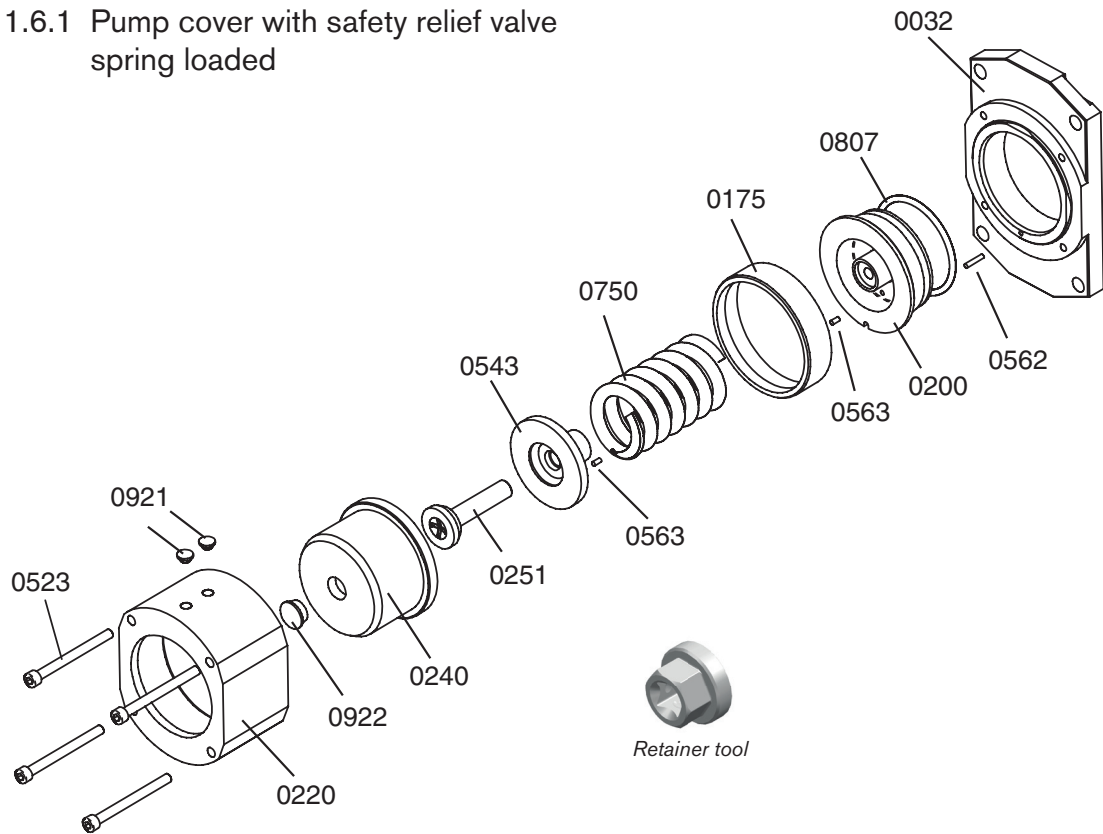

Pos.	Nos./pump	Description	TW1/0041	TW1/0082	TW2/0171	TW2/0343	TW3/0537	TW3/1100
Safety relief valve, complete			3.01915.11		3.01916.11		3.01917.11	
Safety relief valve with jacket, complete			3.01915.51		3.01916.51		3.01917.51	
0032	1	Pump cover valve	3.94800.11		3.94801.11		3.94802.11	
0032	1	Pump cover valve for heating	3.94800.12		3.94801.12		3.94802.12	
0175	1	Support ring	3.94627.11		3.94604.11		3.94642.11	
0200	1	Valve head	3.94624.11		3.94602.11		3.94640.11	
0220	1	Cylinder	3.94869.11		3.94606.11		3.94644.11	
0240	1	Cover spring loaded	3.94633.11		3.94610.11		3.94648.11	
0251	1	Spring adjusting screw	3.94613.21		3.94613.21		3.94651.21	
0523	4	Screw	0.0252.160		0.0252.212		0.0252.316	
0543	1	Spring adjusting plate	3.94636.11		3.94614.11		3.94652.11	
0562	1	Pin	0.0490.657		0.0490.659		0.0490.661	
0563	2	Pin	0.0490.653		0.0490.653		0.0490.654	
0750	1	Spring	3.94635.11		3.94612.11		3.94650.11	
0807	1	O-ring	O-ring kit for hydraulic part with safety relief valve, see chapter 6					
0921	2	Plastic plug	3.94615.11		3.94615.11		3.94615.11	
0922	1	Plastic plug	3.96075.11		3.96075.11		3.96076.11	
	1	Retainer tool			3.94550.31		3.94551.31	

11.6.2 Pump cover with safety relief valve spring loaded - air lifted

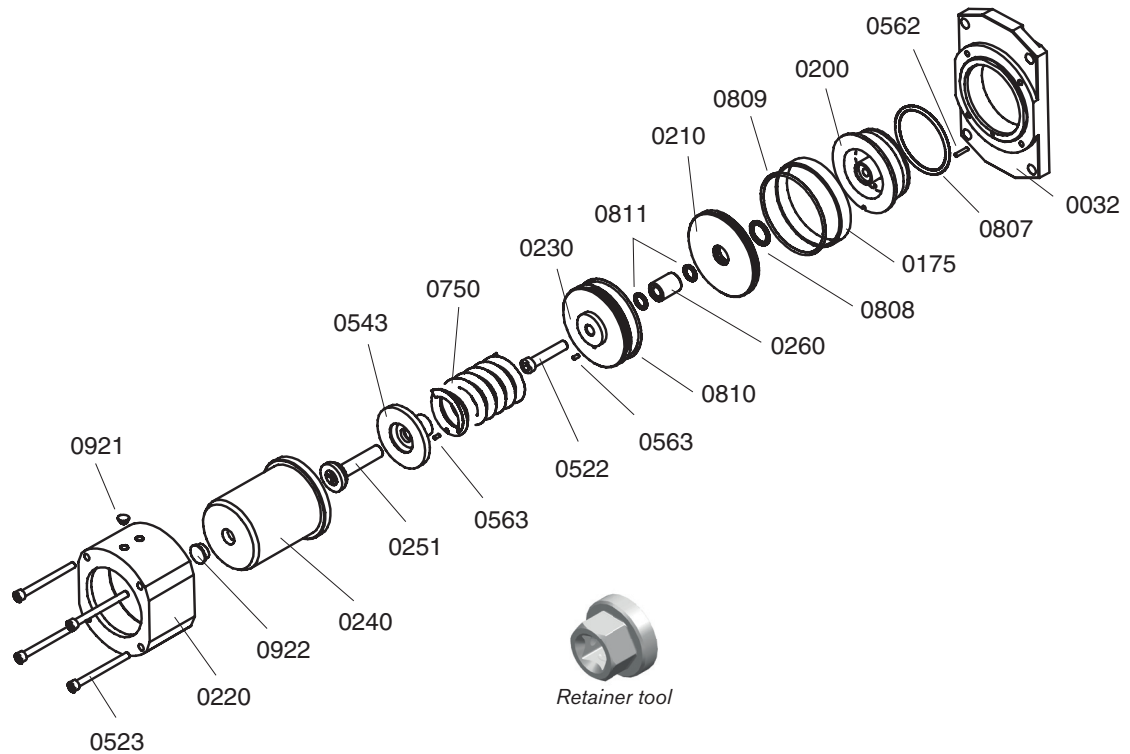

Pos.	Nos./pump	Description	TW1/0041	TW1/0082	TW2/0171	TW2/0343	TW3/0537	TW3/1100	
Safety relief valve, complete			3.01915.12			3.01916.12			3.01917.12
Safety relief valve with jacket, complete			3.01915.52			3.01916.52			3.01917.52
0032	1	Pump cover valve	3.94800.11		3.94801.11		3.94802.11		
0032	1	Pump cover valve for heating	3.94800.12		3.94801.12		3.94802.12		
0175	1	Support ring	3.94626.11		3.94603.11		3.94641.11		
0200	1	Valve head	3.94624.11		3.94602.11		3.94640.11		
0210	1	Baseplate	3.94628.11		3.94605.11		3.94643.11		
0220	1	Cylinder	3.94869.11		3.94606.11		3.94644.11		
0230	1	Piston	3.94630.11		3.94607.11		3.94645.11		
0240	1	Cover spring loaded-air lifted	3.94631.11		3.94608.11		3.94646.11		
0251	1	Spring adjusting screw	3.94613.21		3.94613.21		3.94651.21		
0260	1	Spacer sleeve	3.94634.11		3.94611.11		3.94649.11		
0522	1	Screw	0.0252.249		0.0252.303		0.0252.410		
0523	4	Screw	0.0252.160		0.0252.212		0.0252.316		
0543	1	Spring adjusting plate	3.94636.11		3.94614.11		3.94652.11		
0562	1	Pin	0.0490.657		0.0490.659		0.0490.661		
0563	2	Pin	0.0490.653		0.0490.653		0.0490.653		
0750	1	Spring	3.94635.11		3.94612.11		3.94650.11		
0807	1	O-ring	O-ring kit for hydraulic part with safety relief valve, see chapter 6						
0808	1	O-ring	0.2173.934		3.91864.11		3.92159.11		
0809	1	O-ring	0.2173.967		0.2173.971		0.2173.986		
0810	2	O-ring	0.2173.917		0.2173.972		0.2173.978		
0811	2	O-ring	0.2173.975		3.91860.11		0.2173.979		
0921	1	Plastic plug	3.94615.11		3.94615.11		3.94615.11		
0922	1	Plastic plug	3.96075.11		3.96075.11		3.96076.11		
	1	Retainer tool		-	3.94550.31		3.94551.31		

11.6.3 Pump cover with safety relief valve air loaded - air lifted

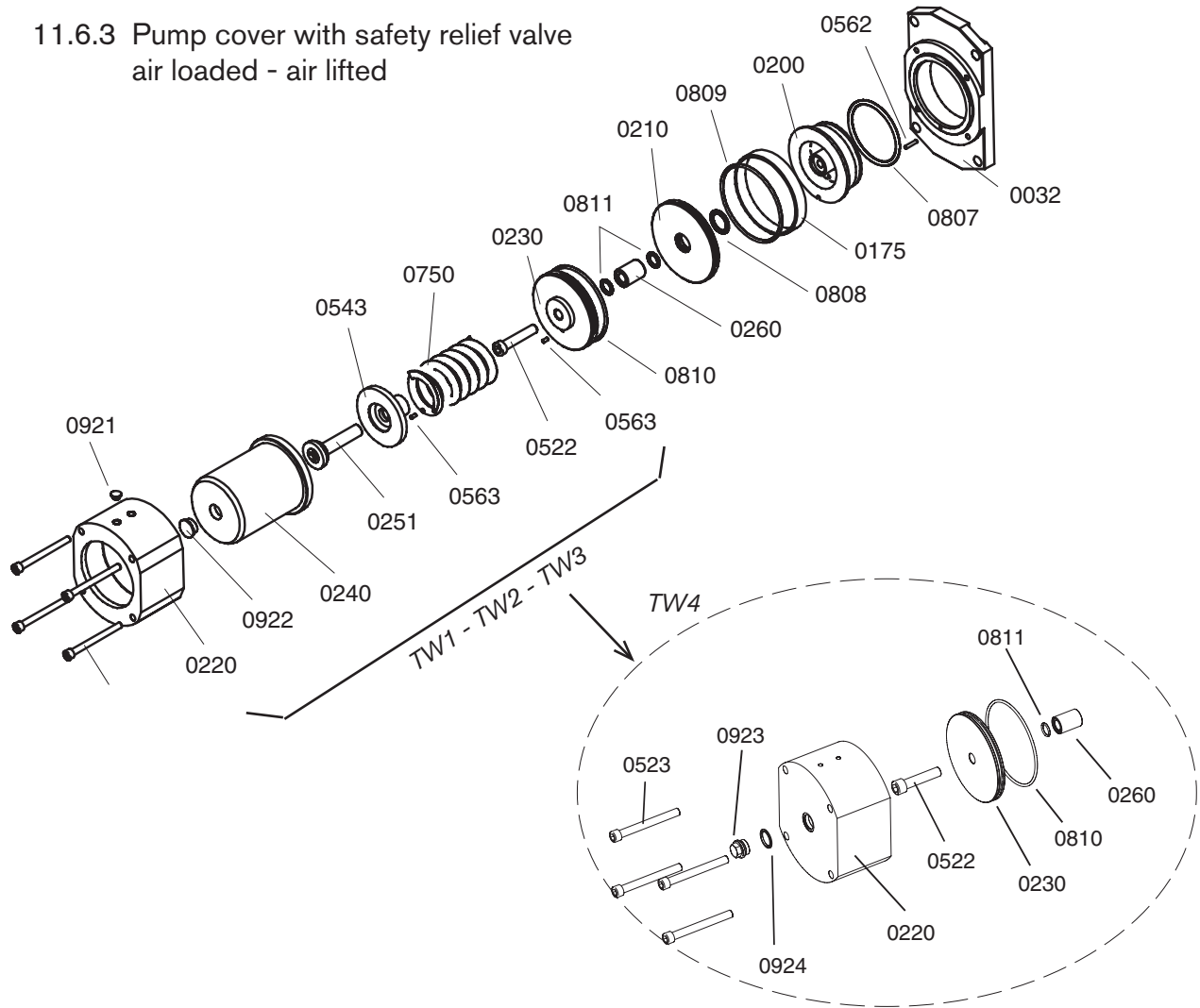

Pos.	Nos./pump	Description	TW1	TW2	TW3	TW4
Safety relief valve, complete			3.01915.13	3.01916.13	3.01917.13	3.01918.13
Safety relief valve with jacket, complete			3.01915.53	3.01916.53	3.01917.53	3.01918.53
0032	1	Pump cover valve	3.94800.11	3.94801.11	3.94802.11	3.94803.11
0032	1	Pump cover valve for heating	3.94800.12	3.94801.12	3.94802.12	3.94803.12
0175	1	Support ring	3.94626.11	3.94603.11	3.94641.11	3.94657.11
0200	1	Valve head	3.94624.11	3.94602.11	3.94640.11	3.94656.11
0210	1	Baseplate	3.94628.11	3.94605.11	3.94643.11	3.94658.11
0220	1	Cylinder	3.94869.11	3.94606.11	3.94644.11	3.94659.11
0230	1	Piston	3.94630.11	3.94607.11	3.94645.11	3.94660.11
0240	1	Cover air loaded-air lifted	3.94632.11	3.94609.11	3.94647.11	-
0260	1	Spacer sleeve	3.94634.11	3.94611.11	3.94649.11	3.94661.11
0522	1	Screw	0.0252.249	0.0252.303	0.0252.410	0.0252.474
0523	4	Screw	0.0252.160	0.0252.212	0.0252.316	0.0252.424
0562	1	Pin	0.0490.657	0.0490.659	0.0490.661	0.0490.676
0807	1	O-ring	O-ring kit for hydraulic part with safety relief valve, see chapter 6			
0808	1	O-ring	0.2173.934	3.91864.11	3.92159.11	0.2173.982
0809	1	O-ring	0.2173.967	0.2173.971	0.2173.986	0.2173.983
0810	2	O-ring	0.2173.917	0.2173.972	0.2173.978	-
0810	1	O-ring	-	-	-	0.2173.984
0811	2	O-ring	0.2173.975	3.91860.11	0.2173.979	0.2173.985
0923	1	Plastic plug	-	-	-	3.94918.11
0924	1	Sealing ring	-	-	-	3.94919.11

TopWing

ULTRA-HYGIENIC
ROTARY LOBE PUMPS

SPXFLOW

SPX Flow Technology Poland Sp. z o.o

ul. Rolbieskiego 2

85-862 Bydgoszcz, Poland

P: +48 (0)52 566 76 00

E: johnson-pump@spxflow.com

SPXFLOW reserves the right to incorporate our latest design and material changes without notice or obligation. Design features, materials of construction and dimensional data, as described in this bulletin, are provided for your information only and should not be relied upon unless confirmed in writing.

Please contact your local sales representative for product availability in your region. For more information visit www.spx.com.

ISSUED 06/2019 A.0500.301 EN

COPYRIGHT ©2019 SPXFLOW Corporation