

# SHOP PRESSES



## THE PREFERRED CHOICE FOR HEAVY-DUTY, RIGID SHOP EQUIPMENT

Every piece of shop equipment goes through a detailed fabrication and assembly process, and is thoroughly inspected to ensure maximum performance in the field.

- Wide selection of H-Frame, C-Frame, and load positioning equipment to fit a wide range of applications.
- Turnkey models from available with a variety of power units ranging in manual, electric, air, and gas-driven variations.
- Array of reservoir sizes from 0.25 to 55 gallons
- Valve configurations, such as dump, 2-way, 3-way and 4-way in manual and solenoid options,
- Hydraulic flow up to 420 cu. in. @ 10,000 PSI.

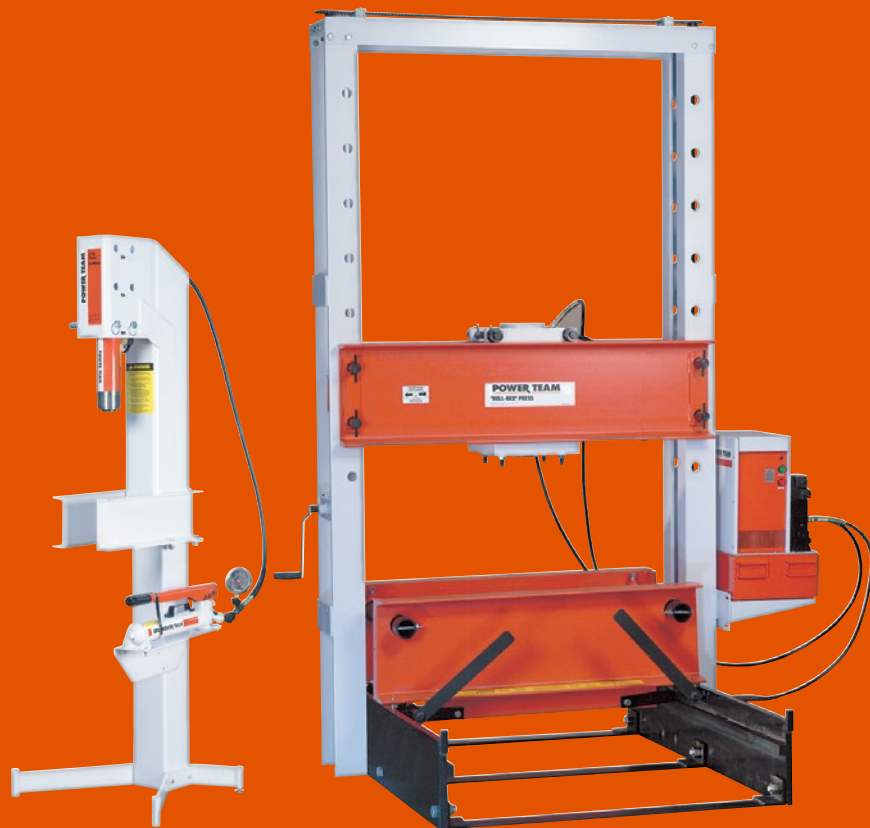



	Section / Series	Shop Equipment	Cylinder Type	Tonnage Range	Pages
	Introduction	—	—	—	147-148
	SPM, SPX	C-Frame	Single-Acting, Spring Return	25	149
	SPM, SPH, SPE	H-Frame	Single-Acting Double-Acting	10	150
	SPA, SPM, SPE	H-Frame Economy	Single-Acting	25	151
	SPA, SPM, SPE	H-Frame Open-End-Access™	Single-Acting Double-Acting	25	152
	SPA, SPM, SPE	H-Frame	Single-Acting Double-Acting	55	153
	SPM, SPE	H-Frame	Single-Acting Double-Acting	100	154
	SPE	H-Frame	Double-Acting	150-200	155-156
	RB	H-Frame Roll-Bed®	Double-Acting	80-200	157-158
	A	Accessories	—	—	159-160
	FC	Floor Cranes	—	—	161
	PT	Bench Vise	—	5	162



## SELECTING THE RIGHT SHOP EQUIPMENT:

**Step 1** What is the largest size of material you will be working with on your application?

**Step 2** What capacity, or pressure, is required to perform the work?

**Step 3** What is the speed, or frequency, the press will be operated. (ad-hock or production use)?

## SHOP EQUIPMENT SIZING CONSIDERATIONS:

Knowing how a hydraulic press operates can help you determine whether or not you need one for your application. If a press is needed, ask yourself these four questions.

1. What is the size of the largest work piece? For arbor and H-Frame presses, this will dictate the throat size (horizontal opening) and daylight (vertical space required).
2. What pressure is required OR what capacity is required? For arbor presses and H-Frame presses this will dictate how much force is required to perform the pressing operation. It is recommended
3. What speed and/or frequency do I need to operate the press?
4. How many parts or operations per shift is required? If the required amounts are quite high, an electric or air model power pump would be more suited verses a manual hand pump.

When selecting Power Team's Shop Equipment, you will need to select the type of press style, cylinder size and prime mover to operate and control the press.

Basic components for our shop equipment:

- A pump (or prime mover) is used to transfer the oil from a reservoir out to the tool. This can be in the form of an electric, air or manual pump.
- A control valve is used to divert or meter the flow / direction / volume of the oil out to the tool.
- A cylinder or work-head is used to fill the area above the piston cap with oil through the A-port. This forces the piston down.
- The control valve then redirects the oil either to the B-port for double-acting cylinders or diverts it back to the reservoir on spring return single-acting cylinders.



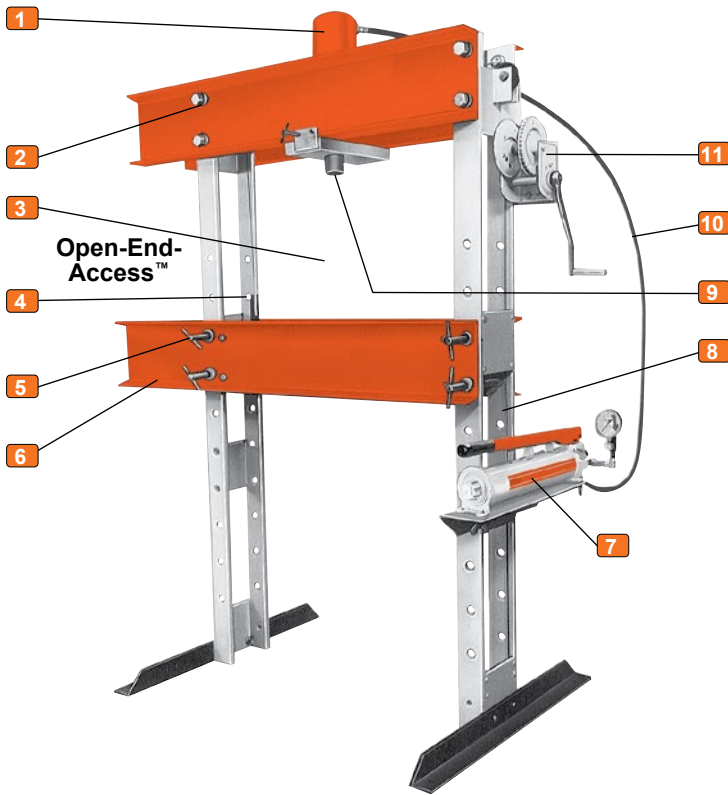

Horizontal pressing capabilities

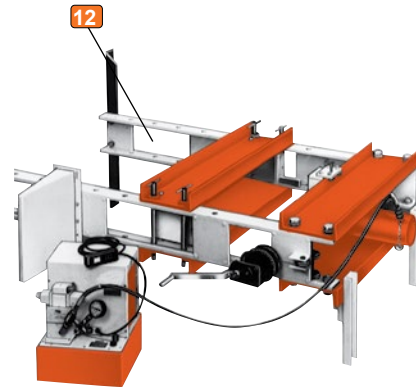

**⚠ IMPORTANT SAFETY INFORMATION:**  
Power Team has protective blankets available which may afford protection from injury to users and others should part breakage occur. Power Team recommends the use of these blankets for all pushing, pulling, pressing, and lifting applications.

- 1 2 TO 1 SAFETY FACTOR**  
Hydraulic cylinders meet ASME B30.1 standards. Single or double-acting cylinders are available.
- 2 FULL RATED CAPACITY**  
Across width of upper frame, even with work-head moved to one side. (Heavy-duty presses only).
- 3 LARGER WORK AREA** than most competitors' models.
- 4 ALIGNMENT LEVER** for simple pin replacement after raising or lowering the bed.
- 5 CLOSE MANUFACTURING TOLERANCE** allows even load distribution over four alloy steel pins, not two, like some competitors. (Heavy-duty presses only).

- 6 OPEN-END-ACCESS™ FEATURE** on 25 ton press provides additional work area by mounting cylinder on outside for C-frame advantage.
- 7 ELECTRIC, AIR OR HAND HYDRAULIC PUMPS** are available. All are standard Power Team pumps. Externally-adjustable relief valve for precise operator control of working pressure is standard on all electric pumps (except PE10 and PE17 series.)  
A 24VAC hand switch for remote control on pumps equipped with solenoid valves.  
**Note: CSA approved electric pumps are standard on all presses.**

- 8 RUGGED UPRIGHTS**, 50 percent stronger than channel iron. Four post design means open side for easy loading of long material.
- 9 FAST CYLINDER APPROACH** to work provided by 2-speed hand, air or electric pumps.
- 10 3/8" I.D. HOSE** on spring return cylinders on heavy-duty presses provides up to six times faster cylinder return than standard 1/4" I.D. hose.
- 11 ONE-PERSON OPERATION** for bed adjustment. Winch unit quickly raises or lowers bed to desired height. Self-locking winch mechanism prevents bed from dropping when handle is released.

- 12 FRAMES CAN BE USED HORIZONTALLY** for pressing jobs on extra-long shafts.  
**NOTE:** Certain features do not apply to Power Team 10 ton, Roll-Bed®, or economy presses.  
**NOTE:** Certain press applications may require guarding. Because of the multitude of possible press uses, it is impossible to design a guard that will meet every customer need. The end-user must provide their own guarding where the situations dictate.

Model Shown:  
**SPM256C**



Shop Equip.

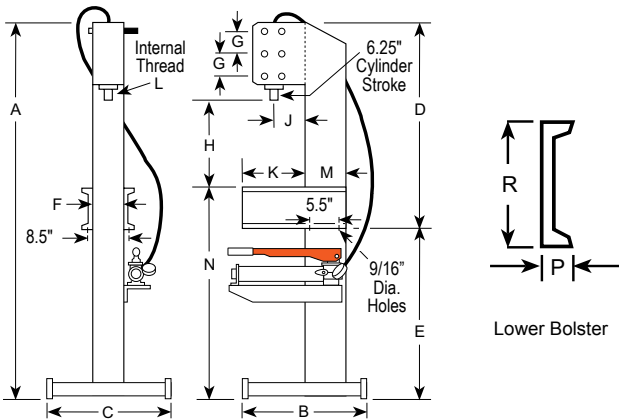

**>Features**

**C-FRAME PRESSES**

- Open-End-Access™ design makes loading and unloading of work easy.
- Bench mount requires less than 1.5 sq. ft. of space.
- Cylinder head adjusts to three convenient working positions, providing up to 20.25" of "daylight."
- Can be bench-mounted or mounted on optional base.
- Hydraulic cylinder delivers a 6.25" stroke and is driven by a P59 two-speed hand pump.



**Optional Pedestal Base**



**No. 60846** – Provides a stable base for SPM256C. Includes a bracket for mounting the pump on the side of pedestal press. Only 4 sq. ft. of floor space is needed. Wt., 76 lbs.



**▶ Technical Dimensions**

A	B	C	D	E	F	G	Cyl. Retracted			J	K	L	M	N	P	R	Floor Space (in.)
							H	I	O								
77.63	24.50	24.00	41.63	36.00	6.00	5.00	10.25	15.25	20.25	6.25	12.50	1 1/2 - 16	8.00	43.00	2.00	7.00	24 x 24.50

**▶ Ordering Information**

Order No.	Cap. (tons)	Type Cyl. Used	Stroke (in.)	Cyl. Model	Speed †† Advance Pressing		Type of Pump	Pump Model	Prod. Wt. (lbs.)
					(in. / stroke)	(in. / stroke)			
SPM256C *	25	Single-Acting	6.25	C256C	0.129	0.03	Hand	P59	240.00
SPX256C *	25	Single-Acting	6.25	C256C	0.129	0.03	—	—	240.00

\* SPM256C and SPX256C does not include No. 60846 pedestal base.

†† Typical performance based on pump specifications. Actual speeds may vary with operating conditions.

Model Shown:

SP1010A, SPM1010



Features

H-FRAME

- Ideal for small pressing jobs, repairing small motor armatures, removing and installing gears, bearings, other press-fit parts.
- Bench press has 15.38" x 18" work area. Floor press bed height is adjustable from 5" to 41" with horizontal "daylight" of 21".
- Choices of power sources include: single-speed hand pump, electric/hydraulic or air/hydraulic.
- Hydraulic gauges, hoses and fittings included.



Pump Electrical Specifications

PE10 Series – 1/4 hp, 115VAC, 60 cycle, single-phase. Also available in 230VAC, 50 cycle (add suffix "-220" to order number).

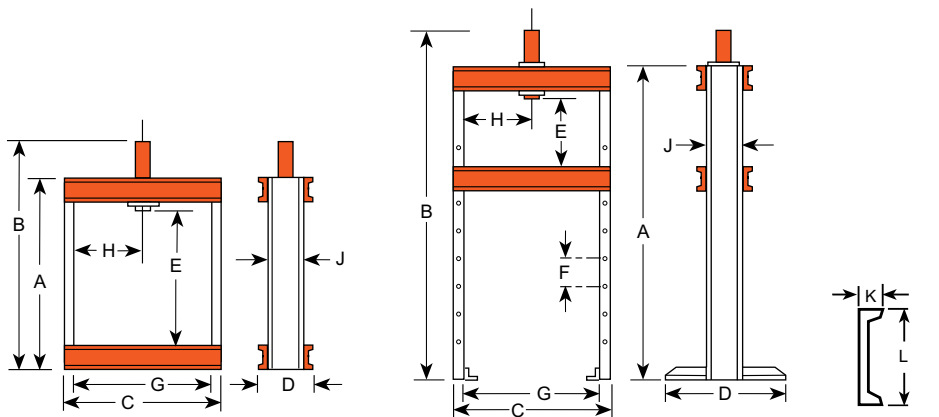

Shop Equip.

Technical Dimensions

Frame	A	B	C	D	E	F	G	H	J	K	L	Bench Space (in.)	Floor Space (in.)
	(in.)	(in.)	(in.)	(in.)	(in.)	(in.)	(in.)	(in.)	(in.)	(in.)	(in.)		
Bench	24.50	33.13	25.25	7.19	15.38	—	22.00	11.00	4.00	1.56	4.00	7.19 x 25.25	—
Floor	59.00	67.63	25.25	28.00	5 - 41	6.00	22.00	2.50 - 18.50	4.00	1.56	4.00	—	28.00 x 28.25

Ordering Information

Order No.	Frame	Cap. (tons)	Type Cyl. Used	Stroke (in.)	Cyl. Model	Speed ††† Advance Pressing		Type of Pump	Pump Model	Prod. Wt. (lbs.)
						(in. / stroke)	(in. / min.)			
SPM1010	222481 Bench	10	Single-Acting	10.13	C1010C	0.06 (in./stroke)	0.06 (in./stroke)	Hand	P55	91.00
SPH1010	222480 Floor	10	Single-Acting	10.13	C1010C	0.06 (in./stroke)	0.06 (in./stroke)	Hand	P55	171.00
SPE1010	222480 Floor	10	Single-Acting	10.13	C1010C	0.53	4.40	Elec. †	PE102	175.00
SP1010A	222480 Floor	10	Single-Acting	10.13	C1010C	0.60	4.00	Air	PA9H	162.00
SPE1010D	222480 Floor	10	Double-Acting	10.00	RD1010	0.53	4.40	Elec. †	PE10	192.00

† "Advance" position holds pressure with motor shut-off. "Return" position advances cylinder with motor running and returns cylinder with motor shut-off.

††† Typical performance based on 100 psi and 10,000 psi pump specifications. Actual speeds may vary with operating conditions.

Model Shown:  
**SPE256**



**Features**

**ECONOMY PRESSES**

- Rugged, yet reasonably priced. Handles many “big press” tasks, and perfect for many of the “in-between” jobs you see almost daily.
- Press bed height easily adjustable with winch. Bed will not drop when handle is released.
- Choice of power sources for rapid cylinder advance: two-speed hydraulic hand pump, electric/hydraulic or air/hydraulic. (**Note:** Stroke length limited to 6-1/4” on economy models).



**Pump Electrical Specifications**

Pump Series	Description
PE17	1/2 hp, 115VAC, 60 cycle, single-phase.
PE21	1 hp, 115VAC, 60 cycle, single-phase.

Both pumps available in 230VAC, 50 cycle, add suffix “-220” to order no.

Shop Equip.

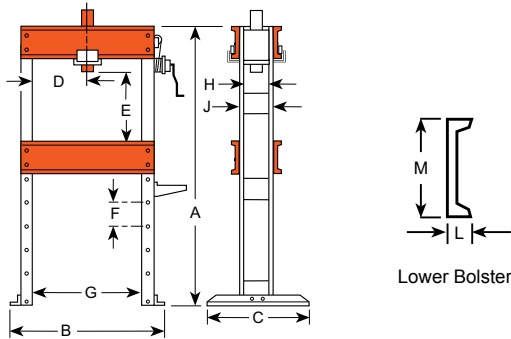

Lower Bolster

**Technical Dimensions**

A	B	C	D*	E	F	G	H	J	K	L	M	Floor Space
(in.)	(in.)	(in.)	(in.)	(in.)	(in.)	(in.)	(in.)	(in.)	(in.)	(in.)	(in.)	(in.)
58.00	43.00	28.00	3 - 29	6.88 - 43.38	4.50	32.00	5.50	6.50	7.00	2.50	8.00	43 x 28

\* Lateral head movement

**Ordering Information**

Order No.	Cap. (tons)	Type Cyl. Used	Stroke (in.)	Cyl. Model	Speed † † † Advance Pressing		Type of Pump	Valve Type	Pump ‡ Model	Prod. Wt. (lbs.)
					(in. / min)	(in. / min.)				
SPA256	25	Single-Acting	6.25	SPA256	9.8	1.2	Air.	2-Way Foot	PA6	578.00
SPM256	25	Single-Acting	6.25	SPM256	0.129	.129 (in./stroke)	Hand.	Load Release	P59	595.00
SPE256	25	Single-Acting	6.25	SPE256	46.60	3.3	Elec.	2-Way † †	PE172	607.00

† † Holds pressure with motor shut-off. Also has an automatic dump setting. Furnished with a 10' remote motor control.

† † † Typical performance based on 100 psi and 10,000 psi pump specifications. Actual speeds may vary under operating conditions.

‡ Pump standard with press. Other Power Team pumps can be substituted. dBA at idle and 10,000 psi: PE172–67/81 dBA; PE21–70; dBA measured at 3 foot distance, all sides.



Model Shown:  
**SPE2514**

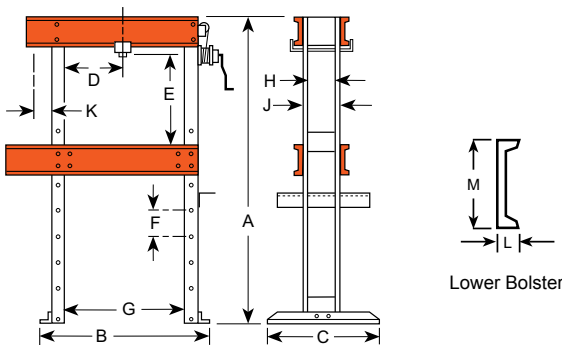

Features

OPEN-END-ACCESS™ PRESSES

- Design permits use as both H-Frame and C-Frame press. Cylinder can be mounted on frame extension to handle jobs which won't fit between uprights.
- Open-end-Access™ press models are also available with remote control to enable the operator to view work from all sides with fingertip control of cylinder piston travel.
- Off-center pressing loads of full capacity can be applied across entire width of frame.
- Press bed height easily adjustable with winch. Bed will not drop when handle is released.
- Choice of power sources for rapid cylinder advance: two-speed hydraulic hand pump, electric/hydraulic or air/hydraulic.



Pump Electrical Specifications

Pump Series	Description
PE17	1/2 hp, 115VAC, 60 cycle, single-phase.
PE21	1 hp, 115VAC, 60 cycle, single-phase.

Both pumps available in 230VAC, 50 cycle, add suffix "-220" to order no.

Shop Equip.

Technical Dimensions

A	B	C	D*	E	F	G	H	J	K	L	M	Floor Space
(in.)	(in.)	(in.)	(in.)	(in.)	(in.)	(in.)	(in.)	(in.)	(in.)	(in.)	(in.)	(in.)
58.00	43.00	28.00	3 - 29	6.88 - 43.38	4.50	32.00	5.50	6.50	7.00	2.50	8.00	43 x 28

\* Lateral head movement

Ordering Information

Order No.	Cap. (tons)	Type Cyl. Used	Stroke (in.)	Cyl. Model	Speed † † † Advance Pressing		Type of Pump	Valve Type	Pump ‡ Model	Prod. Wt. (lbs.)
					(in. / min)	(in. / stroke)				
SPA2514	25	Single-Acting	14.25	C2514C	9.80	1.2	Air	2-Way Foot	PA6	683.00
SPM2514	25	Single-Acting	14.25	C2514C	0.49 (in./stroke)	0.03 (in./stroke)	Hand	Load Release	P159	693.00
SPE2514	25	Single-Acting	14.25	C2514C	46.60	3.3	Elec.	2-Way † †	PE172	665.00
SPE2514S	25	Single-Acting	14.25	C2514C	52.00	4.0	Elec.	3-Way †	PE213S	759.00
SPE2514DS	25	Double-Acting	14.25	RD2514	52.00	4.0	Elec.	4-Way †	PE214S	787.00

† Solenoid valve with 24VAC remote control hand switch.

† † Holds pressure with motor shut-off. Also has an automatic dump setting. Furnished with a 10' remote motor control.

† † † Typical performance based on 100 psi and 10,000 psi pump specifications. Actual speeds may vary under operating conditions.

‡ Pump standard with press. Other Power Team pumps can be substituted. dBA at idle and 10,000 psi: PE172-67/81 dBA; PE21-70; dBA measured at 3 foot distance, all sides.



Model Shown:  
**SPE5513DS**

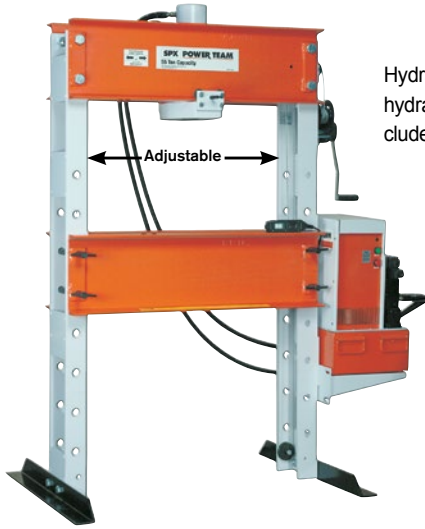

Hydraulic gauge and hydraulic fittings are included with presses.

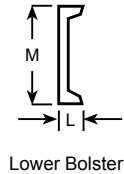
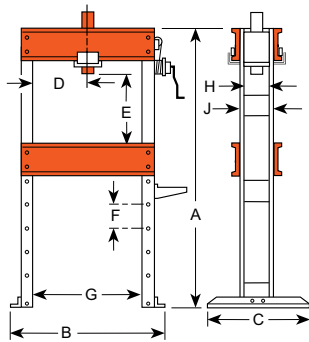

Lower Bolster

Shop Equip.

**Technical Dimensions**

A	B	C	D*	E	F	G	H	J	L	M	Floor Space
(in.)	(in.)	(in.)	(in.)	(in.)	(in.)	(in.)	(in.)	(in.)	(in.)	(in.)	(in.)
72.00	48.50	36.00	3.25 - 32.75	6 - 42	6.00	36.00	6.75	8.00	3.00	12.00	48.5 x 36

\* Lateral head movement

**Ordering Information**

Order No.	Cap. (tons)	Type Cyl. Used	Stroke (in.)	Cyl. Model	Speed ††† Advance Pressing		Type of Pump	Valve Type	Pump ‡ Model	Prod. Wt. (lbs.)
					(in. / min)	(in. / min.)				
SPA556	55	Single-Acting	6.25	C556C	4.5	0.5	Air	2-Way Foot	PA6	804.00
SPM556	55	Single-Acting	6.25	C556C	0.23 (in./stroke)	0.015 (in./stroke)	Hand	Load Release	P159	814.00
SPM5513	55	Single-Acting	13.25	C5513C	0.665 (in./stroke)	0.26 (in./stroke)	Elec.	2-Way	P460	960.00
SPE556	55	Single-Acting	6.25	C556C	21.7	1.5	Elec.	2-Way ††	PE172	836.00
SPE556	55	Single-Acting	13.25	C5513C	21.7	1.5	Elec.	2-Way ††	PE172	980.00
SPE5513	55	Single-Acting	13.25	C5513C	24.4	1.9	Elec.	3-Way †	PE213S	1,056.00
SPE5513D	55	Double-Acting	13.25	RD5513	21.7	1.5	Elec.	4-Way	PE174	993.00
SPE5513DS	55	Double-Acting	13.25	RD5513	66.1	5.4	Elec.	4-Way †	PQ604S	1,114.00

† Solenoid valve with 24VAC remote control hand switch.

†† Holds pressure with motor shut-off. Also has an automatic dump setting. Furnished with a 10' remote motor control.

††† Typical performance based on 100 psi and 10,000 psi pump specifications. Actual speeds may vary with operating conditions.

‡ Pump standard with press. Other Power Team pumps can be substituted. dBA at idle and 10,000 psi: PE172—67/81; PE21 Series—70; PQ60—74/76; measured at 3 foot distance, all sides.

Note: Frame is shipped assembled.

**Features**

**H-FRAME SHOP PRESS**

- Full off-center pressing at full rated capacity across width of upper frame without buckling or bending.
- Maximum “daylight” is 42” x 36”, making positioning of even bulky work pieces easy.
- Height of press bed is easily adjusted with winch. Friction brake prevents bed from dropping and handle from spinning upon release.
- Presses with single-acting cylinders offer choice of 2-speed hand operated, electric/hydraulic, or air/hydraulic pump. Models with double-acting cylinders have an electric/hydraulic pump.
- Press models equipped with remote control enable operator to view work from all sides with fingertip control of cylinder piston travel.
- Press can be used horizontally for special applications with user-supplied support legs.



**Pump Electrical Specifications**

Pump Series	Description
PE17 *	1/2 hp, 115VAC, 60 cycle, single-phase.
PE21 *	1 hp, 115VAC, 60 cycle, single-phase.
PQ60 *	2 hp, 230VAC, 60 cycle, single-phase.

\* Pumps available in 230VAC, 50 cycle, add suffix “-220” to order no.



**Straightening Fixtures**



**No. SF50** – Straightening fixtures for use with 55-ton shop or 80-ton Roll-Bed® presses (2 ea).. Wt., 104 lbs.

**Not part of press, order separately.**

Model Shown:  
**SPE10013DS**



Hydraulic gauge and hydraulic fittings are included with presses.

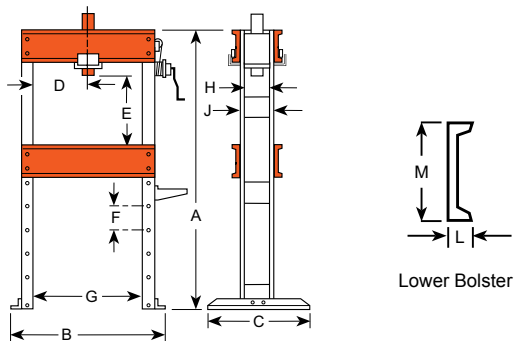

Lower Bolster

Features

H-FRAME SHOP PRESS

- Cylinder work-head glides across upper frame on rollers, locks in place for off-center pressing jobs. May be used horizontally for special pressing applications with user-supplied supports.
- Press bed is raised and lowered by winch which locks in place for insertion of bed retaining pins. Upper bolster can be lowered 8" for convenient positioning on repetitive jobs.
- Generous "daylight" of 42" x 50" accommodates bulky work pieces, uprights are placed for easy side entry of bars or shafts for straightening or bending.
- Choice of single or double-acting cylinder. Hydraulic pump options include: 2-speed hand pump with large 2-gallon reservoir, PE172 electric/hydraulic pump or "PQ" series "Quiet" electric/hydraulic pump with low noise level.



Pump Electrical Specifications

Pump Series	Description
PE17 *	1/2 hp, 115VAC, 60 cycle, single-phase.
PQ60 *†	2 hp, 230VAC, 60 cycle, single-phase.
PQ120 **	3 hp, 460VAC, 60 cycle, three-phase.

\* Pumps available in 230VAC, 50 cycle, add suffix "-220" to order no.

† For 115VAC, consult factory.

\*\* Pump available in 220/380VAC, 50 cycle. To order 380VAC, 50 cycle, add suffix "-380" to order no.



Straightening Fixtures



No. SF150 – Straightening fixtures for use with 100 ton shop press and 100, 150, and 200 ton Roll-Bed® presses (2 ea). Wt., 196 lbs.

Not part of press, order separately.

Technical Dimensions

A	B	C	D*	E	F	G	H	J	L	M	Floor Space
(in.)	(in.)	(in.)	(in.)	(in.)	(in.)	(in.)	(in.)	(in.)	(in.)	(in.)	(in.)
77.25	64.00	36.00	7 - 43	2 - 42	8.00	50.00	8.00	10.00	3.38	15.00	36 x 78.25

\* Lateral head movement

Ordering Information

Order No.	Cap. (tons)	Type Cyl. Used	Stroke (in.)	Cyl. Model	Speed ††† Advance Pressing		Type of Pump	Valve Type	Pump ‡ Model	Prod. Wt. (lbs.)
					(in. / min)	(in. / stroke)				
SPM10010	100	Single-Acting	10.25	C10010C	0.356 (in./stroke)	0.01 (in./stroke)	Hand	3-Way	P460	1,698.00
SPE10010	100	Single-Acting	10.25	C10010C	35.0	2.9	Elec.	3-Way	PQ603	1,795.00
SPE10010R	100	Single-Acting	10.25	C10010C	11.5	0.8	Elec.	2-Way	PE172	1,690.00
SPE10013DS	100	Double-Acting	13.13	RD10013	35.0	5.8	Elec.	4-Way †	PQ1204S	1,886.00

† Solenoid valve with 24VAC remote control hand switch.

††† Typical performance based on 100 psi and 10,000 psi pump specifications. Actual speeds may vary under operating conditions.

‡ Pump standard with press. Other Power Team pumps can be substituted. dBA at idle and 10,000 psi: PE172—67/81; PQ60—74/76; PQ120—73/78. Measured at 3 foot distance, all sides.

Note: Frame is shipped assembled.

Model Shown:  
**SPE20013DS**



Hydraulic gauge and hydraulic fittings are included with presses.

Shop Equip.

**>Features**

**H-FRAME SHOP PRESS**

- Standing 7.5 feet tall, these giants handle the really big jobs.
- May be used horizontally for special pressing applications with user-supplied supports.
- Work-head has wide horizontal travel. Rugged press frame withstands load of rated capacity across full width of frame.
- Winch mechanism provides easy positioning of press bed, locks in place for insertion of retaining pins.
- Upper bolster can be lowered 11" for convenient positioning on repetitive jobs.
- Uprights are placed for easy side entry of bars or shafts for straightening or bending.
- Fast cylinder approach is provided by PQ1204S "Quiet" electric/hydraulic pump.
- Remote control hand switch, enables operator to view work from all sides with fingertip control of cylinder piston travel.



**Pump Electrical Specifications**

Pump Series	Description
PQ120	3 hp, 460VAC, 60 cycle, three-phase. Also available in 220/380VAC, 50 cycle, add suffix "-380" to order no.

NOTE: To order press with 230VAC, 60 cycle, single-phase pump, order press less PQ1204S. Order pump No. PQ604S separately.



**Optional HD Straightening Fixtures**



**No. SF150** – Straightening fixtures for use with 100 ton shop press and 100, 150, and 200 ton Roll-Bed® presses (2 ea).  
Wt., 196 lbs.

**Not part of press, order separately.**



Adjustable head accommodates a wide array of applications



Winch provides easy positioning of press bed



Large footing for a solid base and stability

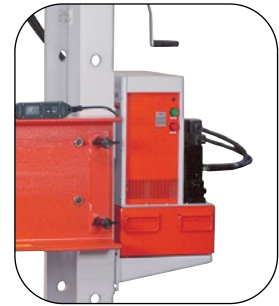

PQ120 Series pump provides the pressure and control

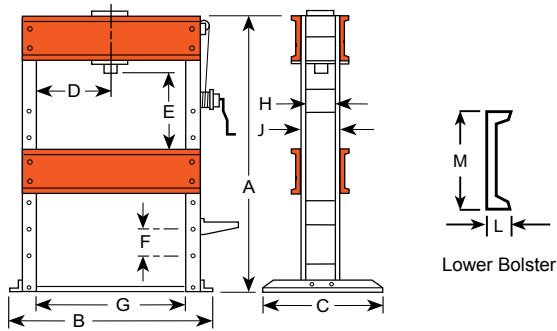

Shop Equip.

Technical Dimensions

A	B	C	D*	E	F	G	H	J	L	M	Floor Space
(in.)	(in.)	(in.)	(in.)	(in.)	(in.)	(in.)	(in.)	(in.)	(in.)	(in.)	(in.)
90.00	71.00	44.00	11 - 39	9 - 43.75	11.00	50.00	12.50	15.00	4.13	18.00	44 x 71

\* Lateral head movement

Ordering Information

Order No.	Cap. (tons)	Type Cyl. Used	Stroke (in.)	Cyl. Model	Speed † † † Advance Pressing		Type of Pump	Valve Type	Pump ‡ Model	Prod. Wt. (lbs.)
					(in. / min)	(in. / min.)				
SPE15013DS	150	Double-Acting	13.13	RD15013	24	3.9	Elec.*	4-Way **	PQ1204S	3,015.00
SPE20013DS	200	Double-Acting	13.13	RD20013	18	2.9	Elec.*	4-Way **	PQ1204S	3,276.00

Note: Frame is shipped assembled.

\* Pre-wired at factory for 460VAC.

\*\* Solenoid valve with 24VAC remote control hand switch.

† † † Typical performance based on 100 psi and 10,000 psi pump specifications. Actual speeds may vary under operating conditions.

‡ Pump standard with press. dBA at idle and 10,000 psi: 73/78, measured at 3 foot distance, all sides.

Model Shown:  
**RB10013S**



Hydraulic gauge and hydraulic fittings are included with presses.

Shop Equip.

▶ **Roll-bed enables easy loading and unloading of large gears to simplify the pressing operation.**

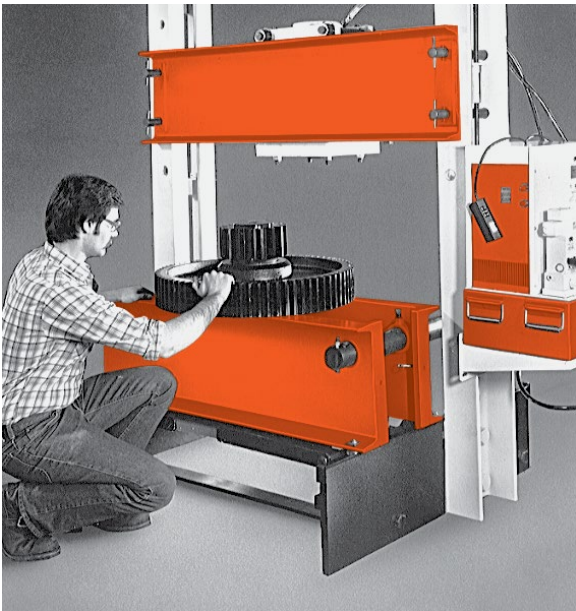

**Features**

**H-FRAME ROLL-BED® PRESS**

- The original, patented Roll-Bed® extends out for easy loading and unloading with a crane or other lifting device, supporting loads up to 3,000 lbs.
- Movable work-head glides easily side-to-side for full off-center load capacity across width of upper frame.
- "Daylight" is 50.5" x 60" for 80 and 100 ton models; 51.25" x 64" on 150 and 200 ton presses.
- Fast approach of double-acting, 13.125" stroke cylinder is provided by PQ1204S "Quiet" electric/hydraulic pump with remote control hand switch. Operator can view work from all sides with fingertip control of cylinder piston travel.
- Adjustable lower bed width for secure balancing and centering of heavy jobs.
- Lifting mechanism has a turn crank handle to raise or lower upper bolster (a heavy-duty 1/2" drill motor can replace handle for automatic adjustment). Four locking pins hold bolster in place for pressing.



**Optional HD Straightening Fixtures**



**No. SF50** – Straightening fixtures for use with 55-ton shop or 80 ton Roll-Bed® presses (2 ea). Wt., 104 lbs.

**Not part of press, order separately.**



**No. SF150** – Straightening fixtures for use with 100 ton shop press and 100, 150, and 200 ton Roll-Bed® presses (2 ea). Wt., 196 lbs.

**Not part of press, order separately.**



**Pump Electrical Specifications**

Pump Series	Description
PQ120	3 hp, 460VAC, 60 cycle, three-phase. Available in 220/380VAC, 50 cycle, add suffix "-380" to order no.

**NOTE:** To order press with a 230VAC, 60 cycle, single-phase pump, order press less PQ1204S. Order pump No. PQ604S separately.

**NOTE:** Different voltage and valve options can be obtained by substituting certain PA, PE or PQ series pumps. Consult the factory.





Lifting screw and locking pins make bolster raising a one-man job.



Bearings make bed positioning smooth and easy.



Lever lowers bed for pressing, raises it for rolling.



Cylinder is easily moved across width of upper bolster.

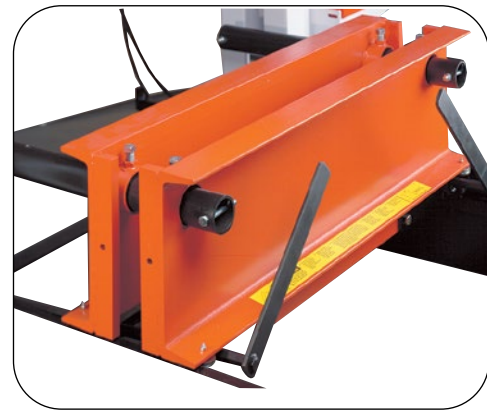
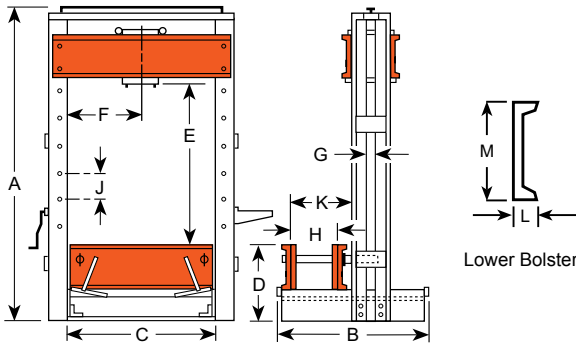

Width adjusts from 4" to over 27" & is secured with locking bolts.

Shop Equip.

► Technical Dimensions

Cap.	A	B	C	D	E	F	G	H	J	K	L	M	Floor Space
(Tons)	(in.)	(in.)	(in.)	(in.)	(in.)	(in.)	(in.)	(in.)	(in.)	(in.)	(in.)	(in.)	(in.)
80	112.63	64.25	50.50	27.00	12 - 60	14.50 - 36.00	3.00	4.00 - 27.25	8.00	36.50	3.38	15.00	64.25 x 60.50
100	112.63	64.25	50.50	27.00	12 - 60	14.50 - 36.00	3.00	4.00 - 27.25	8.00	36.50	3.38	15.00	64.25 x 60.50
150	123.25	68.25	51.25	30.00	9 - 64	13.88 - 37.88	3.00	4.00 - 27.13	11.00	37.25	4.13	18.00	68.25 x 63.25
200	122.25	68.25	51.25	30.00	9 - 64	15.13 - 36.13	3.00	4.00 - 27.13	11.00	37.25	4.13	18.00	68.25 x 63.25

► Ordering Information

Order No.	Cap. (tons)	Type Cyl. Used	Stroke (in.)	Cyl. Model	Speed † † † Advance Pressing		Type of Pump	Valve Type	Pump ‡ Model	Prod. Wt. (lbs.)
					(in. / min)	(in. / min.)				
RB8013S	80	Double-Acting	13.13	RD8013	46	7.5	Elec.	4-Way †	PQ1204S	2,886.00
RB10013S	100	Double-Acting	13.13	RD10013	35	5.8	Elec.	4-Way †	PQ1204S	2,944.00
RB15013S	150	Double-Acting	13.13	RD15013	24	3.9	Elec.	4-Way †	PQ1204S	4,458.00
RB20013S	200	Double-Acting	13.13	RD20013	18	2.9	Elec.	4-Way †	PQ1204S	4,546.00

Note: Frame is shipped assembled.

† Solenoid valve with 24VAC remote control hand switch.

††† Typical performance based on 100 psi and 10,000 psi pump specifications. Actual speeds may vary with operating conditions. 3,000 lbs. maximum load can be supported on bed when raised on the rollers.

‡ Pump standard with press. dBA at idle and 10,000 psi: PQ120-73/78; measured at 3 foot distance, all sides.

**RUBBER TIRE REMOVING/INSTALLING SET**



Pressing rim into new tire on Power Team Press.

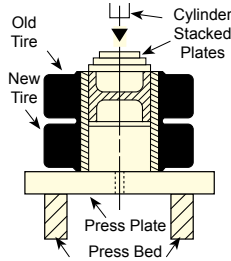

Now an easy way to press solid rubber tires. The TPP200 uses plates instead of combination rings to press a rim from an old tire into a new one. P They can be used on any Power Team press with 55 ton capacity or more.

**NOTE:** Many tires require 100 tons of force or more, depending on tire size and condition. These plates withstand maximum force of 150 tons.

Order No.	Description
TPP200	Tire press plate set. Includes 13 press plates, spacer pushing adapter and press bed plate.
<b>NOTE:</b> For use on solid rubber tires from 4" to 17 - 3/4" I.D.	

**TIRE PRESS PLATE SET, TPP200**

Model Shown:

**TBP1622, TPP1 - TPP13, TPS6**

Shop Equip.

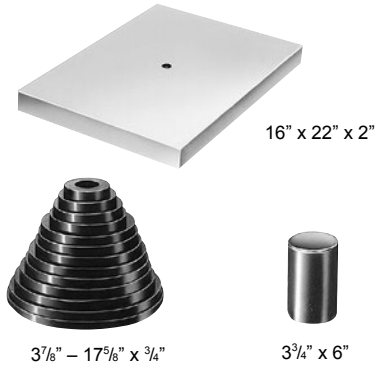

Order No.	Tire Size I.D. (in.)	Tire Size O.D. (in.)
TPP1	4	3.88
TPP2	5	4.88
TPP3	6, 6.25	5.88
TPP4	6.50	6.38
TPP5	8	7.88
TPP6	10	9.88
TPP7	10.50	10.38
TPP8	11.25	11.13

Order No.	Tire Size I.D. (in.)	Tire Size O.D. (in.)
TPP9	12, 12.13	11.88
TPP10	14	13.88
TPP11	15	14.88
TPP12	16	15.88
TPP13	17.75	17.63
TPS6	Spacer/Pushing Adapter	3.75 x 6
TBP1622	Bed Plate	16 x 22 x 2

**"V" BLOCKS**

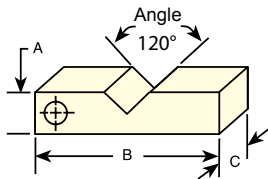

Order No.	Width	Length	Thick
	A (in.)	B (in.)	C (in.)
1890	2.00	9.00	1.25
1891	2.50	11.50	1.75
1892	3.50	14.00	2.00
1893	5.00	14.00	1.50
207395	5.75	23.00	2.50

**THREAD ADAPTER**

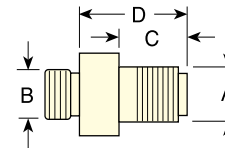

Order No.	A (in.)	B (in.)	C (in.)	D (in.)
38597	1 - 8	1 - 8	0.75	1.31
38953	1.25 - 7	1.5 - 16	2.75	4.38
37368	1.63 - 5.5	—	1.69	2.50
43562	2.25 - 12	—	2.25	3.00
38954	1.63 - 5.5	1.69 - 8	3.25	4.19
43563	2.25 - 12	2.75 - 12	2.25	3.19
46070	2.25 - 12	2 - 4.5	2.25	3.19



PRESS ACCESSORY KIT

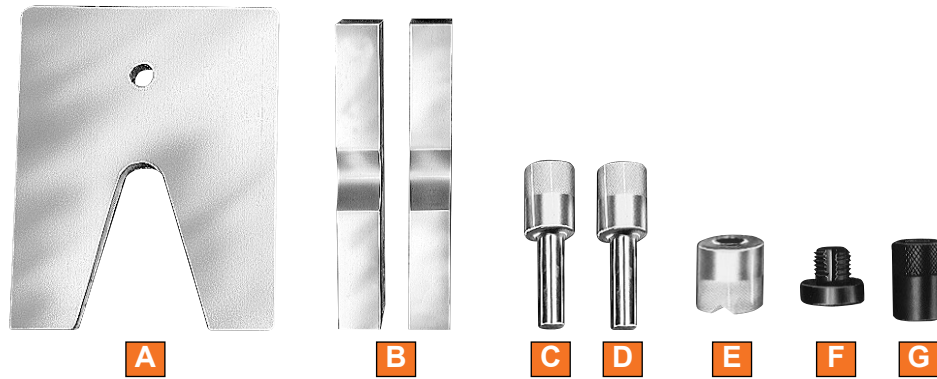

Make your Power Team press even more versatile with one of these accessory sets. These sets will eliminate makeshift set-ups. Many of these items can be used with pullers you already have.

Ordering Information

Use With Press (Ton)	Order No.	V-Throat Press Plate	V-Blocks	Pushing Adapter ⚠	Pushing Adapter ⚠	V-Pushing Adapter	Threaded Adapter		Pushing Adapter
							Single-Acting Cyls.	Double-Acting Cyls.	
							F		
10	SPA10	1888	1890 (2)	201923 1/2" Dia. Shank	201454 3/4" Dia. Shank	34806	38597 †	38597 †	—
25	SPA25	1889	1891 (2)	34510 3/4" Dia. Shank	34511 1" Dia. Shank	34807	38953 ††	38953 ††	—
55	SPA55	—	1892 (2)	34755 1" Dia. Shank	34756 1 1/2" Dia. Shank	34808	37368 ††	38954 ††	—
80/100	SPA100	—	1893** (2)	—	—	36469	43562 †† 46070 ††	43563 †† 46070 ††***	21332
150/200	SPA200	—	207395 (2)	—	44458* 2 1/4" Dia. Shank	44457	—*	—	—

† Included in Set

†† Not Included, Order Separately

\* Pushing adapters thread directly into RD15013 and RD20013 cylinders.

\*\* V-blocks, 1893, are recommended for use with 80 ton Roll-Bed® press. Not recommended for use with 100 ton Roll-Bed® press.

\*\*\* For 80 ton Roll-Bed® press.

**⚠ CAUTION: Pushing adapters are designed for use with specific shaft sizes, and depending on the condition of the shaft ends, the adapter may not withstand the full press tonnage. Always use a protective blanket or other suitable guard when pressing.**

Shop Equip.

Model Shown:

**FC2200**

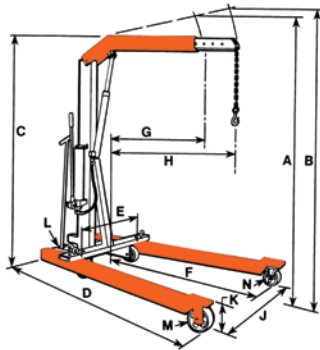
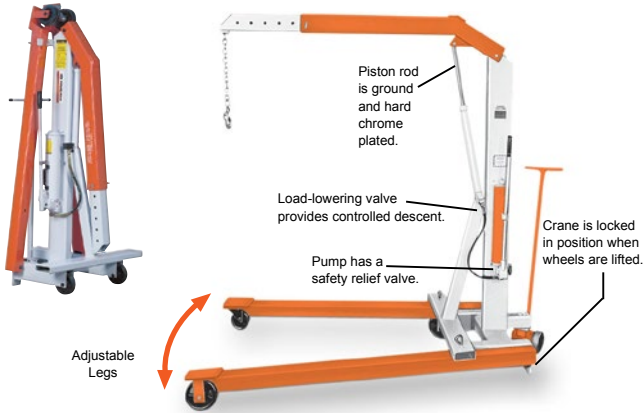

Shop Equip.

**Ordering Information**

Order No.	Description
FC2200	2,200 lbs. cap. crane with fold-away feature, adj. leg spread, lifting chain and 2-speed hand pump. Wt., 454 lbs.
FC4400	4,400 lbs. cap. crane with fold-away feature, adj. leg spread, lifting chain and 2-speed hand pump. Wt., 646 lbs.

**Features**

**Mobile Floor Cranes**

- Adjustable legs spread to clear obstacles (telescoping boom for extra reach)
- Rugged construction, reliable hydraulics.
- Boom collapses completely and legs fold for compact space-saving fold-away storage
- 2-speed hydraulic hand pump provides fast boom travel and precise operator controlled descent.
- Roller bearing wheels and a steering dolly provide ease of mobility. Lifting chain is included.
- U.S. Patent No. 3,367,512

**Technical Dimensions**

	Description	FC2200	FC4400
A	Max. boom height (ret.)	107"	111"
B	Max. boom height (ext.)	117"	122"
C	Overall height, boom horizontal	80"	82"
D	Overall length	83"	89"
E	Min. throat width	24"	25"
F	Inside leg length	54"	57.5"
G	Eff. boom reach (ret.)	33"	35.5"
H	Eff. boom reach (ext.)	48"	50.5"
J	Inside leg width	24" - 36" - 48" (3-Position)	26" - 40" - 52.5" (3-Position)
K	Leg height	8"	9.5"
L	Dolly wheel diameter	5"	5"
M	Wheel diameter	6"	8"
N	Caster diameter	6"	6"
	Floor space, folded	27" x 38"	31" x 42"
	Height, folded	79"	86"
	Cap. boom ret. (lbs.)	2,200	4,400
	Cap. boom ext. (lbs.)	1,650	3,300

**FLOOR CRANE ACCESSORIES, SPREAD-TILTER™**

Model Shown:

**LR2000, LR4000, LR6000**



**Features**

Whenever you have big, heavy components to move or position, nothing helps you get the job done easier and faster than Power Team's Load-Rotors®

- The heavy-duty Load-Rotors®, when used with a crane or hoist, greatly reduce time and effort.
- LR2000 (2,000 lbs. cap.) and LR4000 (4,000 lbs. cap.) heavy-duty lifting slings are just right, for lifting or positioning components.
- LR6000 has a self-locking worm and gear set in the Spread-Tilter™ head permits rapid angle adjustment of the component being handled.

**Ordering Information**

Order No.	Cap.	Chain Size	Chain Lg. with Swivel Hooks	Lifting Eye Opening	Hex Drive End	Gear Ratio	Prod. Wt.
	(lbs.)	(in.)	(in.)	(in.)	(in.)		(lbs.)
LR2000	2,000	0.25	56.00	1.25	0.63	34:1	9.00
LR4000	4,000	0.31	65.00	1.75	0.63	82:1	23.00
LR6000	6,000	0.31	65.00	1.63	0.63	82:1	73.00

Model Shown:  
PTPHV859SPX



\*Air supply is required when using a hydraulic pump

> Features

**HANDS-FREE HYDRAULIC BENCH VISE WITH COMBINATION 10,000 PSI (690 BAR) FOOT PUMP, PROVIDES 5 TONS OF CLAMPING FORCE.**

- Includes an air control valve for variable speed and safety
- Vise operates vertical or horizontal configurations for project flexibility
- Vise jaws open up to 8" (203 mm) for large holding requirements

▶ Includes

Components	Model Number
5-Ton Hydraulic Vise	PTPHV859
Hold-Ets Magnetic Vise Clips	PTHE3
10,000 PSI (690 Bar) Foot Pump	PA6
Gauge	9040
Gauge Adapter	9670
Hose 10'	9758
Female Coupler	9796
Male Coupler	9798

Shop Equip.

MAGNETIC VISE CLIPS

Model Shown:  
PTHE3

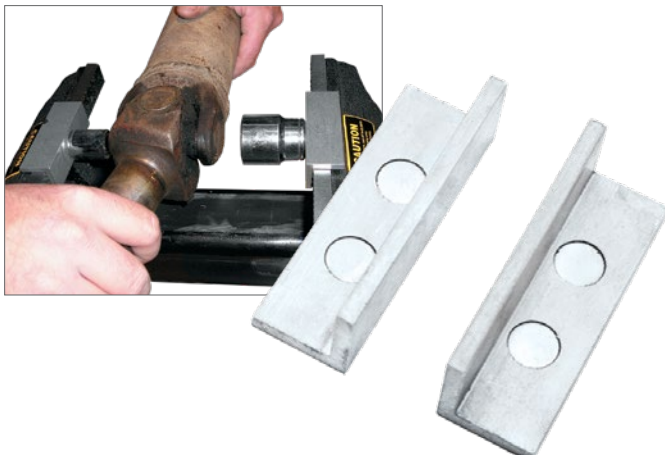

> Features

- Magnetically hold sockets for assembling and disassembling universal joints
- Provides 3" (76 mm) of rigid aluminum construction and superior magnetic locking power to hold screws, rings, c-clips, and springs
- Makes any job a one-man operation with superior strength to hold 5.5 lbs (2.49 kg) vertically and 2.75 lbs (1.24 kg) pounds horizontally
- Can be used as a jaw liner for non-marking material and hold threaded objects rigid without damage to threads