



Tigerloop®

en-CA

Tigerloop® – Automatic oil de-aerator

The Tigerloop® is a product designed to meet increasing demands on energy savings, environmental and operational safety. Environmental regulations and changes in oil qualities continue to place high demands not only on material selection, but also on clean and air-free oil for optimal combustion with minimal discharge of harmful particles. Tigerloop® makes it possible to use a one-pipe system in all types of heating installations, thus ensuring the most environmentally safe method for transporting oil from the oil tank to the burner.

Tigerloop® combines the advantages for the oil pump of a two-pipe system with advantages from the oil tank of a one-pipe system. When using a one-pipe system and Tigerloop®, only the amount of oil used by the oil burner is drawn from the oil tank. As the oil flow decreases, so does the amount of dirt particles transported from the tank. This results in cleaner combustion.

The pressurized return line to the oil tank is removed, thus eliminating the risk for hazardous leakage. A large amount of air bubbles are released when oil is drawn from the oil tank to the oil burner. These air bubbles cause breakdowns, increased soot and excessive wear on the oil pump. By functioning as an automatic de-aerator, Tigerloop® eliminates all such problems.

Technical data

Max. nozzle capacity	20 gph
Max. return oil pumped into the Tigerloop®	30 gph
Max. oil flow	50 gph
Max. operating temperature	105° F (40° C)
Max. ambient temperature	105° F (40° C)
Max. operating pressure in feed line	8 PSI
Pump connection	¼" female thread
Tank connection	¼" female thread

Before installing, check technical requirements and warnings carefully!

When installing Tigerloop® always observe all local codes and ordinances!

Remember to install the pump's bypass plug!

Installation

The Tigerloop® should be installed close to the burner. However, it should be noted that the Tigerloop® should not be exposed to temperatures in excess of 105°F (40°C). It should not, therefore, be installed on an uninsulated furnace or above the cover of a firebox or flue pipe. It must be mounted firmly in a straight upright position. Oil resistant lines must be used for connection between the oil pump and the Tigerloop®. Use the arrows under the feed and return ports of the Tigerloop® as a reference to avoid incorrect piping. The feed line should be pressure tested to ensure that it is completely tight. However, the Tigerloop® must not be connected during pressure testing.

The appropriate dimension of the feed line depends on pipe resistance and suction head. The decisive elements for determining the pipe resistance are the length and size of the pipe and the capacity of the oil burner nozzle. In a one-pipe system, the flow of the feed line is identical to the nozzle capacity.

SPX®

Manufactured by
SPX Flow Technology Stockholm AB, SWEDEN
www.tigerholm.com

When sizing the feed line from the tank to the burner, it is important that the total resistance does not exceed the capacity of the pump.

Note that choosing too large a feed line diameter for the nozzle size should be avoided as too much air (and gas) is formed, with the result that there is no siphon effect and oil runs only in a thin stream along one side in the descending parts of the pipe. In such cases, it is not the height from the oil tank to the oil burner, which should be considered in calculated suction head, but rather all ascending parts of the pipe (including the suction line in the tank, see fig. 1).

In order to avoid possible problems, each burner or appliance should have its own separate suction line. Also, we recommend one Tigerloop® for each burner. Remember to use nozzle capacity (oil consumption) to calculate the dimension of the suction line.

For larger capacities, we recommend the Tigerloop® Twin (see fig. 2). Read more about the Tigerloop® Twin and other HVAC products on our website at www.tigerholm.com

Fig. 1

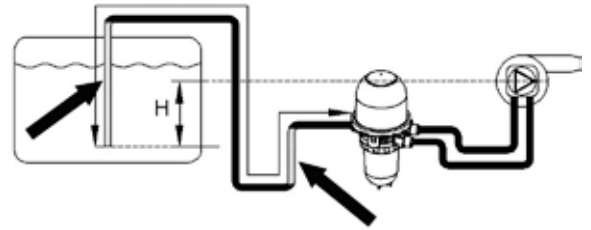
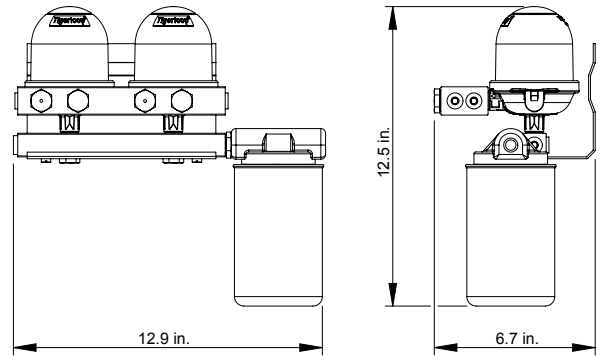

Fig. 2



Caution

1. Install the oil de-aerator in an upright position and securely so it cannot come loose.
2. Installation must be performed by a qualified technician familiar with local codes and ordinances and licensed by proper authority where applicable.
3. The UL-Listed unit must always be installed with a UL-Listed shut-off valve, which is threaded into the center port with the arrow facing towards the center. The shut-off valve should be equipped with a fusible-type handle, which melts at 165°F.
4. Maximum inlet pressure is 8 psi. If the maximum pressure exceeds 8 psi, an Oil Safety Valve (OSV), or equivalent, must be installed.
5. Never install a shut-off valve or other device, which can impede flow in the lines between the oil de-aerator and the oil pump.
6. The completed installation must be tested for correct functioning and safety before leaving.
7. Never use Tigerloop® for other oils than No. 1 and No. 2.
8. Only 1 (one) burner unit per Tigerloop® connection.

Cleaning

When cleaning the Tigerloop® exterior, only mild soap and water are to be used. No alcohol based cleaning agents are to be used.

Trouble shooting

Excessive foaming in the oil de-aerator

Possible causes:

1. Suction leakage. Check all connections and lines.
2. The feed line can be empty. Start the burner by pushing the reset button and let it run. If the burner trips out, wait and reset. Repeat a couple of times. The burner should not run without oil for more than 5 minutes.
3. The tank is almost empty.
4. Incorrectly dimensioned suction line.
5. Too large burner capacity. Install Tigerloop® in parallel.

Noise from the oil pump

Possible causes:

1. Suction leakage. Check all connections and lines.
2. Too high suction head.

Oil is not sucked up from the tank

Possible causes:

1. Large suction leakage. Check all connections and lines.
2. Too high suction head.
3. The bypass plug is not installed in the oil pump. Fit the plug.

Oil level in the Oil De-Aerator

The level of oil in the lower chamber of the oil de-aerator may vary depending on the installation conditions. For example, with an air-tight suction line and air-free oil where the oil tank is placed higher than the burner, the air pocket in the lower chamber of the de-aerator may slowly disappear until the lower chamber is completely filled with oil.

IMPORTANT! This is not a problem. The oil de-aerator is functioning correctly. As conditions change and air enters the system, an air pocket will again form in the lower chamber of the de-aerator. A small amount of oil in the upper chamber caused by foaming is not a problem. However, if the upper chamber of the Tigerloop® becomes full of oil, the unit is damaged and must be replaced.

Since today's oil qualities place a very high demand on materials, the Tigerloop® is to be replaced after 10 years.