

D4 / D4 SL

DOUBLE SEAT MIX PROOF VALVES

FORM NO.: H338791 REVISION: US-2

READ AND UNDERSTAND THIS MANUAL PRIOR TO OPERATING OR SERVICING THIS PRODUCT.



Content	Page
1. General Terms	4
2. Safety	4
2.1 Symbols	
2.2 Safety Instructions	
3. Intended Use	5
4. Mode of Operation	6
4.1. General terms	
4.2. Valve in "closed" position	
4.3. Valve in "open" position	
5. Control Units / Valve Position Indication	8
5.1. Control unit and adapter	
5.2. Valve position indication	
6. Cleaning	9
6.1. Flow area	
6.2. Seat area - D4 SL valve	
6.3. Seat area and Leakage chamber	
6.4. Cleaning recommendation	
6.5. Cleaning of upper area - D4 SL valve	
6.6. Cleaning of lower area - D4 SL valve	
7. Installation and Commissioning	11
7.1. Welding Instructions	
8. Dimensions / Weights	12
8.1. D4 Valve	
8.2. D4 SL Valve	
9. Technical Data	14
9.1. General data	
9.2. Compressed air quality	
9.3. Cvs values	
9.4. Air consumption / Switching times	
9.5. Valve stroke / Opening cross section	
10. Maintenance	17
11. Service Instructions	18
11.1. Removal from the line system	
11.2. Removal of product-wetted parts	
11.3. Installation of product-wetted seals and assembly of the valve	
11.4. Installation of the valve insert	
12. Maintenance of Actuator	22
12.1 Removing the actuator screws	
12.2 Installing the seals and assembling the actuator	
13. Assembly Instructions and Tools for Seals	23
13.1. Lower shaft seal	
13.2. Middle seal	
13.3. Seat seals	
14. Trouble Shooting	26
15. Spare Parts Lists	26
D4 1,5"-4", DN40-100	RN 500.047.01
D4 6", DN125-150	RN 500.047.03
D4 SL 1,5"-4", DN40-100	RN 501.047.01
D4 SL 6", DN125-150	RN 501.047.03

1. General Terms

This instruction manual should be read carefully by the competent operating and maintenance personnel.

We point out that we will not accept any liability for damage or malfunctions resulting from the non-compliance with this instruction manual.

Descriptions and data given herein are subject to technical changes.

2. Safety

2.1 Symbols



Caution!

The technical safety symbol draws your attention to important directions for operating safety. You will find it wherever the activities described are bearing health hazards and risks for persons and / or material assets.



Important Note!

Critical technical information

2.2 Safety Instructions



Opening of the actuators and upper shafts is strictly forbidden. Danger to health and life!

Actuators and upper shafts which are no longer used and/or are defective must be disposed in professional manner.

Defective actuators and upper shafts must be returned to your SPX FLOW company for their professional disposal and free of charge for you.

Please address to your local SPX FLOW company.



- Never touch the valve or pipelines during hot liquid or sterilisation processes!



- Disconnect electric and pneumatic connections, e.g. before maintenance.



- Before any maintenance work, depressurize the line and cleaning system and discharge the lines if possible.

2. Safety



- Observe Service Instructions to ensure safe maintenance of the valve.



- Connections which are not used must be sealed by a plug!



- The safe discharge of the cleaning liquids must be ensured.



- The valves must be assembled, disassembled and reassembled only by persons who have been trained in the valves or by SPX FLOW service team members. If necessary, contact your local SPX FLOW representative.

3. Intended Use

The intended use as field of application of the double seat mix proof valve is the safe shut-off of pipeline sections and the separation of incompatible liquids in the food and beverage industries as well as in pharmaceutical and chemical applications.



Caution! The standard D4 / D4 SL valve must not be used in explosive atmospheres.



Caution! Arbitrary, structural changes at the valves may affect safety as well as the intended functionality of the valves and are not permitted.

SPX FLOW Valves are intended for use in the food and beverage industries, as well as in pharmaceutical and chemical applications.

SPX FLOW Valves (without safety function) are allocated to Category 1 and are evaluated as per Conformity Assessment Module A of the Pressure Equipment Directive 2014/68/EU. According to Article 13, the following allocation applies for the fluids processed in the valves.

Product media – Fluid group 2 – valves in all dimensions.

CIP-cleaning liquids – Fluid group 1 – valves in the dimensions $\leq 4''$ (DN100) can be used at temperatures up to 284°F (140°C), valves in the dimensions $> 4''$ (DN100) at temperatures up to 212°F (100°C).

Authorizations and External Approvals

To view the certifications for this and other innovative SPX FLOW products, visit

<https://www.spxflow.com/en/waukesha-cherry-burrell/about-us/certifications/>

It is within the responsibility of the plant operator to evaluate and verify the suitability of SPX FLOW products for the intended purpose and service conditions, as well as to determine and follow the applicable laws for the intended applications and areas of application.

4. Mode of Operation

fig. 4.1. D4 valve

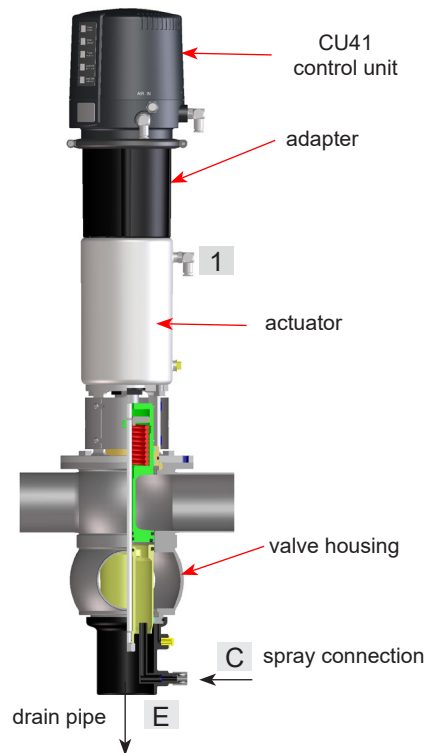

4.1. General terms

Due to its construction and mode of operation as well as to the use of high quality stainless steel and adequate seal materials, the D4 and D4 SL double seat mix proof valves are suited for applications in the food and beverage industries as well as in pharmaceutical and chemical applications.

- The D4 and D4 SL valves separate two line passages by two balanced and independently operating valve shafts with an intervening leakage chamber.
- The valve opens from the top to the bottom in a low-leakage design.
- Leakages are discharged via the drain pipe (E) in depressurized state.
- The pneumatic actuator opens the valve via the air connection (1). The spring force resets the valve into the “closed” safe position.
- The standard D4 valve is equipped with a non-seat lift actuator and a CU41 control unit.
- The standard D4 SL valve is equipped with an actuator including seat lift function and a CU43 control unit.
- D4 SL valve:
Cleaning of the seat is controlled via the air connections.
2 = to lift upper shaft
3 = to lift lower shaft
- The spray connection (C) cleans the leakage chamber.
- As an option, the closed and open positions of the D4 and D4 SL can be detected via proximity switches.

fig. 4.1.1. D4 SL valve

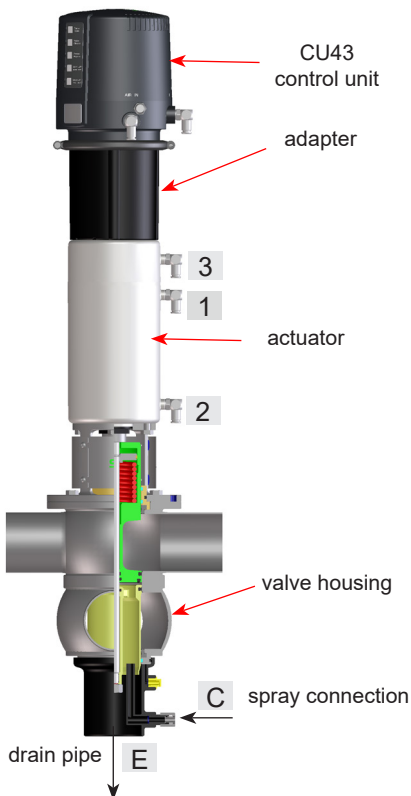
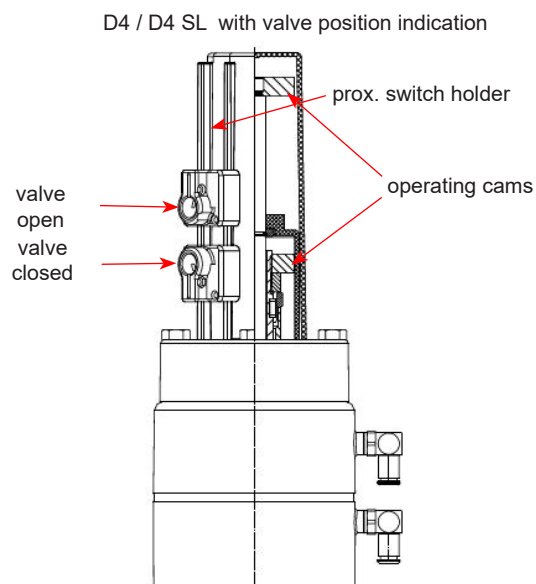
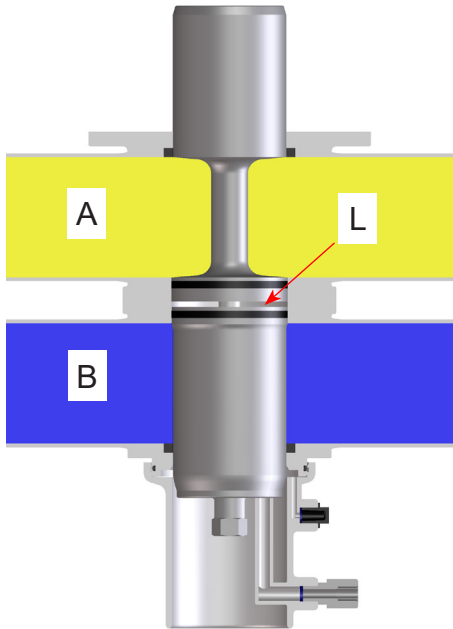

fig. 4.1.2.



4. Mode of Operation

fig. 4.2.



4.2. Valve in "closed" position

The lower and upper valve shaft are in closed position and safely separate the different liquids A and B. The leakage chamber L, which is situated between the two valve shafts, provides for a free and depressurized discharge to the bottom. The valve shafts are balanced and protected against pressure hammer.

fig. 4.3.

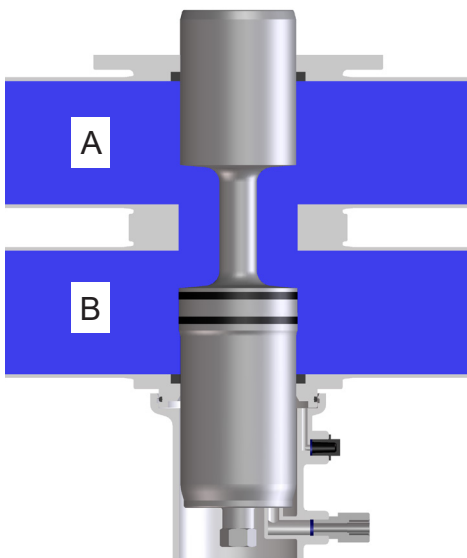

4.3. Valve in "open" position

The upper valve shaft is pressed against the seal of the lower valve shaft by control of the actuator. First, the leakage chamber L is closed against the product chamber. Then the two valve shafts move downwards into the open position. The connection between the two pipelines A and B is established.

5. Control Units / Valve Position Indication

CU4 control unit



5.1. Control unit and adapter

An adapter is required to assemble the control unit on the D4/D4 SL valve.

The following designs are available:

Designation	D4	D4 SL
Ø Air connection	1/4" OD	1/4" OD
CU4 Control Unit		
Direct Connect	CU41-D4 Direct Connect H336959	CU43-D4 Direct Connect H336960
Direct Connect M12	CU41-D4-M12 Direct Connect M12 H341351	CU43-D4-M12 Direct Connect M12 H341352
AS-interface extended	CU41-D4 AS-i extended H336961	CU43-D4 AS-i extended H336962
AS-interface extended M12	CU41-D4-M12 AS-i extended M12 H338900	CU43-D4-M12 AS-i extended M12 H338901
AS-interface standard	CU41-D4 AS-i standard H338151	CU43-D4 AS-i standard H338153
AS-interface standard M12	CU41-D4-M12 AS-i standard M12 H338902	CU43-D4-M12 AS-i standard M12 H338903
Adapter	CU4 adapter D4 H337098	
CU4plus Control Unit		
AS-interface extended V1	CU41plus-D4-V1 AS-i extended V1 H338823	CU43plus-D4-V1 AS-i extended V1 H338824
AS-interface extended V1 M12	CU41plus-D4-V1-M12 AS-i extended V1 M12 H338868	CU43plus-D4-V1-M12 AS-i extended V1 M12 H338869
Adapter	CU4plus adapter D4 V1 H336441	

5.2. Valve position indication

Proximity switches to signal the closed and open position of the valve can be installed at the proximity switch holder.

We recommend using one of these standard types:

three-wire proximity switch

operating distance: 0.196" (5 mm)

diameter: 0.433" (11 mm)

operating voltage: 10–30 V DC

pnp pulse-shifting, closing function

"non-flush" installation

Recommendation:

Proximity switch 24V DC, PNP, 11 mm DIA. (5 m cable): H16223

Proximity switch 24V DC, PNP, 11 mm DIA. (cable box): H16432

If the customer decides to use valve position indicators other than those listed above, SPX FLOW cannot assume any liability for the functionality of the valve.

6. Cleaning

In the cleaning process of the valves, distinction is made between the following areas: Flow areas, Seat area, and Leakage chamber.

6.1. Flow area

The CIP-fluid cleans the upper and lower passages of the valve during CIP.

6.2. Seat area - D4 SL valve (chapters 6.5. and 6.6.)

The seat area and leakage chamber are cleaned through lifting of the individual valve shafts during cleaning of the respective passage.

6.3. Seat area and Leakage chamber

CIP spraying cleans the seat area and the leakage chamber. The cleaning connection is at item C in fig. 6.3.

D4 valve: CIP spraying must generally be undertaken.

CIP spraying does not produce pressure build-up in the leakage chamber. SPX FLOW recommends performing CIP-spraying in the closed valve position; however, it can also be done in the open valve position.

Under standard conditions 15 valves 1.5"-4" (DN40-100), 10 valves 6" (DN125-150) can be cleaned via one spray distribution line 1" (DN25).

6.4. Cleaning recommendation

Cleaning steps	Seat lifting cycle (D4 SL)	CIP spraying
pre-flushing	–	3 x 10 sec.
caustic flushing 80°C	3 x 5 sec.	3 x 10 sec.
intermediate flushing	2 x 5 sec.	2 x 10 sec.
acid flushing	3 x 5 sec.	3 x 10 sec.
subsequent flushing	2 x 5 sec.	2 x 10 sec.

- **D4 SL Valve:** The lifting cycles refer to a cleaning pressure of $p = 29 - 72$ psi (2-5 bar).
- Depending on the pressure ratio, cleaning temperatures, cleaning steps and degree of soiling, time and number of cycles must be adjusted.
- Flushing quantities per CIP spraying cycle:

1.5"-4" (DN40-100)	about 0.32 US gal/10s (1.2 ltr/10s)
6" (DN125-150)	about 1.32 US gal/10s (5.0 ltr/10s)
- Cleaning pressure at CIP cleaning connection:

min. 29 psi (2 bar)
max. 72 psi (5 bar)

Caution!

The cleaning liquid applied must be compatible with the respective seal material.

fig. 6.3.

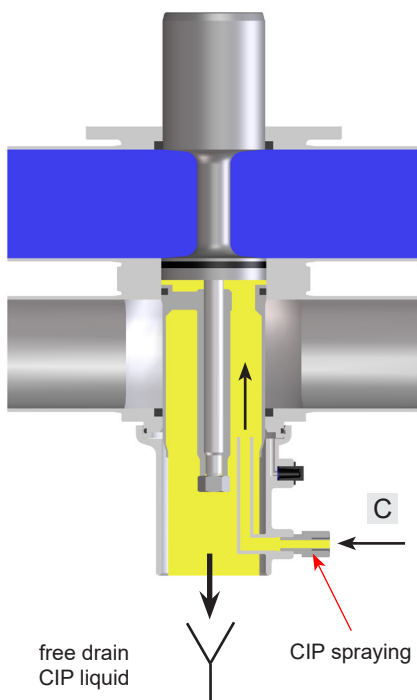

6. Cleaning

fig. 6.5.

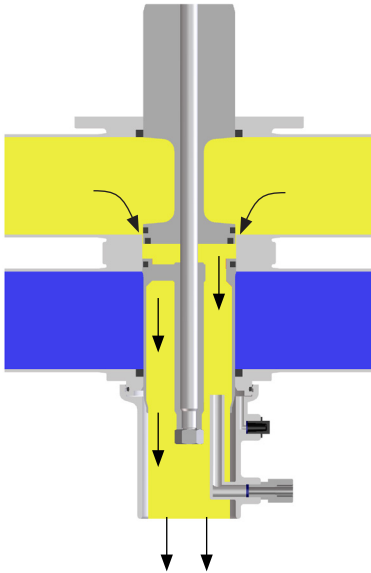

6.5. Cleaning of upper area - D4 SL valve (fig. 6.5.)

The upper valve shaft is lifted via connection (2), as shown in fig. 4.1.1 on page 6.

Through the lifting of the upper valve shaft, the cleaning fluid flushes over the upper seat seal and the upper valve seat into the leakage chamber and cleans this area. The cleaning fluid is drained off to the bottom in a depressurized state.

The lifting stroke is limited by a stop in the actuator.

fig. 6.6.

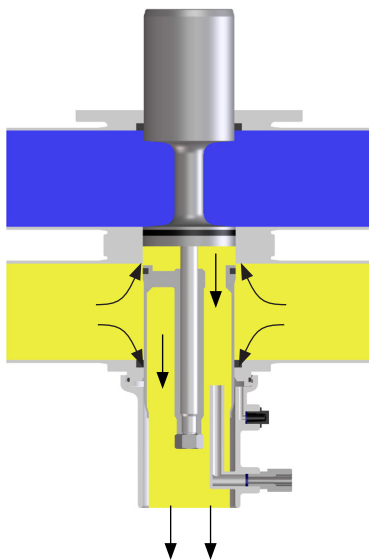



6.6. Cleaning of lower area - D4 SL valve (fig. 6.6.)

The lower valve shaft is lifted via connection (3), as shown in fig. 4.1.1 on page 6.



Through the lifting of the lower valve shaft, the cleaning fluid flushes over the lower seat seal into the leakage chamber and cleans this area. The cleaning fluid is drained off to the bottom in a depressurized state.

The lifting stroke is limited by a stop in the actuator.

7. Installation and Commissioning

- The valve must be installed in vertical position to ensure that fluids can drain off freely from the valve housing and the leakage chamber.
-  **Caution!** Leakages and fluid losses from seat lifting and CIP-spraying must be safely collected and drained!
- The valve housing can be welded directly into the pipeline (completely removable valve insert).
-  **Note!** Observe welding instructions.
- Observe heights of installation and dismantling!
-  **Caution!**
Before first startup:
- Actuate the valve by applying compressed air. The opening, closing and shaft lifting processes must run smoothly.
 - Check the function of the control unit or valve position indication.
 - Check for possible leakages during commissioning. Replace defective seals.

7.1. Welding Instructions

- Before welding the valve, remove the valve insert from the housing.
-  **Caution!** Handle and store the valve insert carefully to avoid damaging the parts.
-  **1.5-4" (DN40-100):** Remove the lower shaft seal and guide ring from the housing.
- 6" (DN125-150):** It is not necessary to remove the lower shaft seal as it can be damaged during dismantling.
- Welding should only be carried out by certified welders (DIN EN ISO 9606-1) (seam quality DIN EN ISO 5817).
 - The welding of the valve housings must be undertaken in such a way that the valve body is not deformed.
 - The preparation of the weld seam up to 0.12" (3 mm) thickness must be carried out as a square butt joint without air. Consider shrinkage!
 - TIG orbital welding is recommended.
-  **Caution!** After welding the valve housing or mating flanges, and after performing any work on the piping, do not operate the valves until the corresponding areas of the installation and piping have been cleaned and welding residue has been removed. If the piping is not cleaned before operation, welding residue and dirt particles can settle in the valves and cause damage to the valves and seals.
- If these welding instructions are not followed, any resulting damage will not be covered by the warranty.
 - Welding directives for aseptic applications shall be drawn from the AWS/ANSI Directives and EHEDG Guidelines.

8. Dimensions / Weights

8.1. D4 Valve

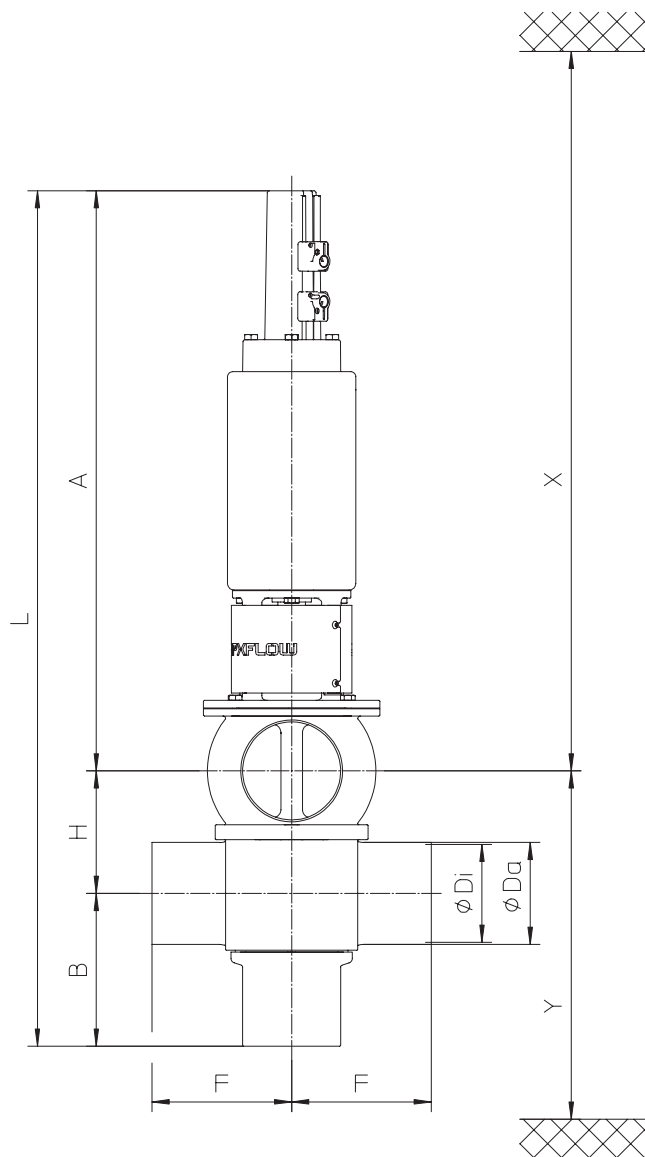

CU4 control unit

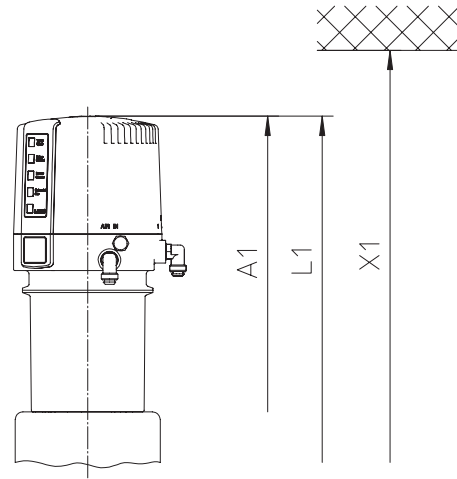

housing configuration

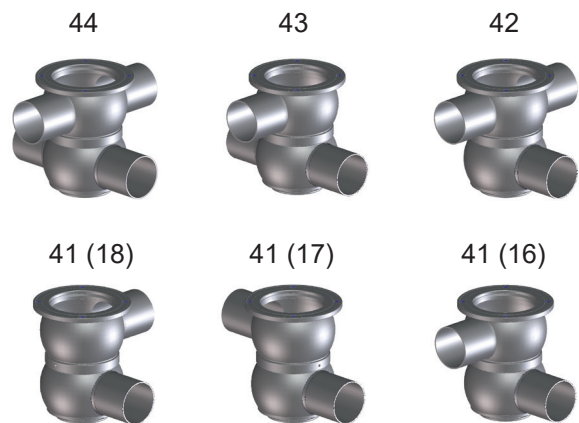

Dimensions in IN										install. dimen. min. in IN			weights in lb. with CU
Size	A	A1	B	$\varnothing Da$	$\varnothing Di$	F	H	L	L1	X*	X1*	Y*	
1.5"	19.1	22.3	4.7	1.5	1.4	4.9	2.5	26.2	29.5	27.9	31.1	7.8	32.8
2"	19.2	22.4	4.9	2.0	1.9	4.9	3.0	27.1	30.4	29.1	32.3	8.5	33.0
2.5"	19.4	22.8	5.2	2.5	2.4	4.9	3.4	27.9	31.2	29.9	33.0	9.2	34.6
3"	22.9	26.2	5.4	3.0	2.9	4.9	3.9	28.9	32.1	31.1	34.6	9.9	35.5
4"	23.4	26.6	6.1	4.0	3.8	5.6	4.9	34.4	37.7	37.0	40.5	11.9	55.7
6"	28.6	31.3	7.6	6.0	5.8	5.9	6.9	43.1	45.7	42.5	45.8	15.4	108

*Minimum installation and valve insert removal dimensions

NOTE: Add the following approximate dimension to "F" for each clamp port connection 0.5" for valve sizes 1.5" - 3.0", 0.62" for valve size 4".

8. Dimensions / Weights

8.2. D4 SL Valve

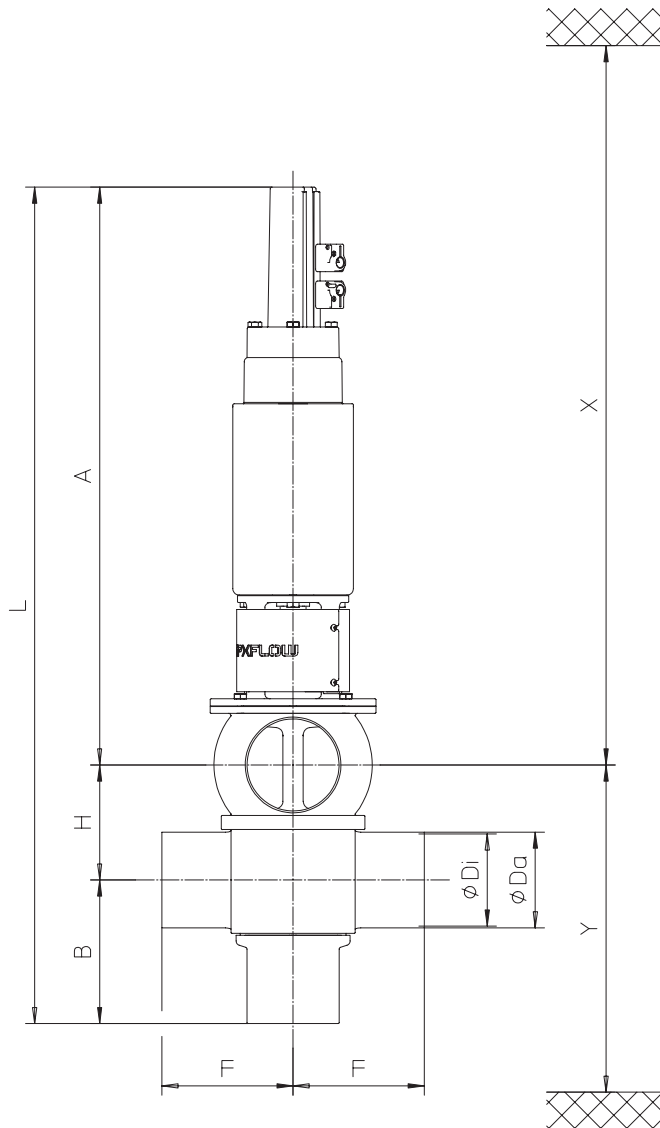

CU4 control unit

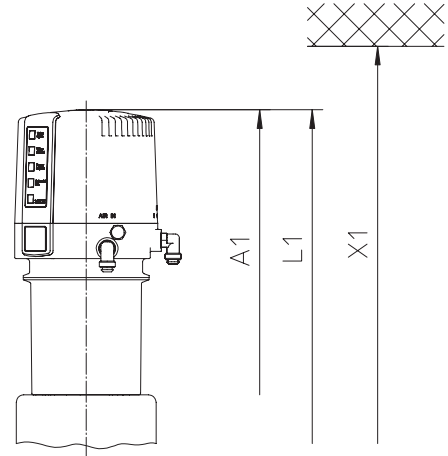

housing configuration

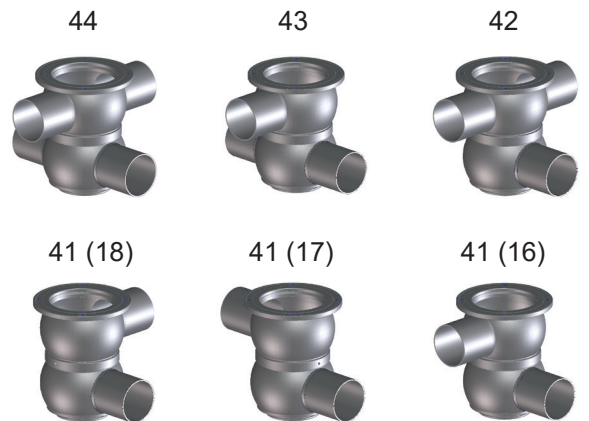

Dimensions in IN										install. dimen. min. in IN			weights in lb. with CU
Size	A	A1	B	Ø Da	Ø Di	F	H	L	L1	X*	X1*	Y*	
1.5"	20.7	24.0	4.7	1.5	1.4	4.9	2.5	27.9	31.1	29.5	33.1	7.8	34.2
2"	20.8	24.1	4.9	2.0	1.9	4.9	3.0	28.7	32.0	30.7	33.8	8.5	34.4
2.5"	21.0	24.3	5.2	2.5	2.4	4.9	3.4	29.5	32.8	31.5	35.0	9.2	35.9
3"	21.3	24.5	5.4	3.0	2.9	4.9	3.9	30.5	33.8	32.7	36.2	9.9	36.8
4"	24.8	28.0	6.1	4.0	3.8	5.6	4.9	35.8	39.1	38.6	41.7	11.9	57.1
6"	28.6	31.3	7.6	6.0	5.8	5.9	6.9	43.1	45.7	42.5	45.8	15.4	118

*Minimum installation and valve insert removal dimensions

NOTE: Add the following approximate dimension to "F" for each clamp port connection 0.5" for valve sizes 1.5" - 3.0", 0.62" for valve size 4".

9. Technical Data

9.1. General data

Product-wetted parts	AISI 316L (1.4404) (DIN EN 10088)
Other parts	AISI 304 (1.4301) (DIN EN 10088)
Seals	
1,5"-4" standard (DN40–100)	EPDM
1,5"-4" options (DN40–100)	HNBR, FPM
6" standard (DN125-150)	EPDM/PTFE compound
6" options (DN125-150)	HNBR/PTFE compound FPM/PTFE compound
Max. line pressure	145 psi (10 bar)
Max. operating temperature	275°F (135°C) EPDM, HNBR FPM*
Short-term load	284°F (140°C) EPDM, HNBR FPM* *no steam
Valves > 4" (DN100)	CIP cleaning liquids up to 212°F (100°C)
Tightening torque for stop sleeve	7 ft-lb (10 Nm)
Tightening torque for safety nuts at lower and upper valve shaft	29 ft-lb (40 Nm)
Spray connection	PP (polypropylene)
Ø Cleaning connection	
1.5-4" (DN 40–100)	0.315 x 0.039" (8x1 mm)
6" (DN125-150)	0.393 x 0.039 (10x1 mm)
Ø Air connection	1/4" OD
Max. pneumatic air pressure	116 psi (8 bar)
Min. pneumatic air pressure	72 psi (5 bar)

9.2. Compressed air quality

Quality class	acc. to DIN ISO 8573-1
Content of solid particles	quality class 3, max. size of solid particles per m ³ 10000 of 0.5 µm < d < 1.0 µm 500 of 1.0 µm < d < 5.0 µm
Content of water	quality class 3, max. dew point temperature -20°C For installations at lower temperatures or at higher altitudes, consider additional measures to reduce the pressure dew point accordingly.
Content of oil	quality class 1, max. 0.01 mg/m ³

The oil applied must be compatible with Polyurethane elastomer materials.

9. Technical Data

9.3. Cvs values in gpm

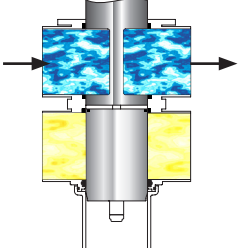
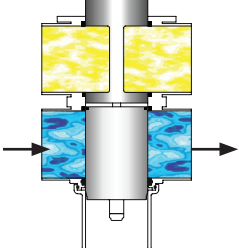
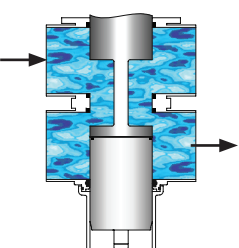
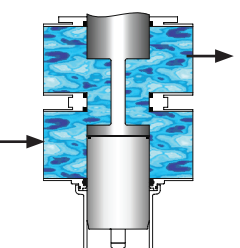
Size								
	D4	D4 SL	D4	D4 SL	D4	D4 SL	D4	D4 SL
1.5"	50	49	44	44	36	28	35	27
2"	101	96	82	82	59	53	59	53
2.5"	180	170	141	141	86	77	83	77
3"	222	212	185	185	102	96	98	95
4"	415	424	274	274	197	193	176	180
6"	941	941	638	638	449	449	431	431

9.4. Air consumption / Switching times

D4 Valve	Air consumption at 72 psi (5 bar)	Switching times in seconds at 72 psi (5 bar) / CU41	
	Actuator	Open	Closed
Size	ft ³ /stroke valve open		
1.5"	0.06	1.0	1.4
2"	0.06	1.1	1.7
2.5"	0.07	1.7	2.0
3"	0.07	1.7	2.0
4"	0.13	2.6	3.3
6"	0.30	3.5	9.3

D4 SL Valve	Air consumption at 72 psi (5 bar)			Switching times in seconds at 72 psi (5 bar) / CU43	
	Actuator	Seat lift actuator		Open	Closed
Size	ft ³ /stroke valve open	ft ³ /stroke upper seat lift	ft ³ /stroke lower seat lift		
1.5"	0.05	0.12	0.008	1.5	1.7
2"	0.06	0.12	0.008	1.5	1.7
2.5"	0.06	0.12	0.008	1.6	1.9
3"	0.07	0.12	0.008	1.7	2.0
4"	0.13	0.27	0.008	2.6	3.3
6"	0.30	0.58	0.026	3.5	9.3

9. Technical Data

9.5. Valve stroke / Opening cross section

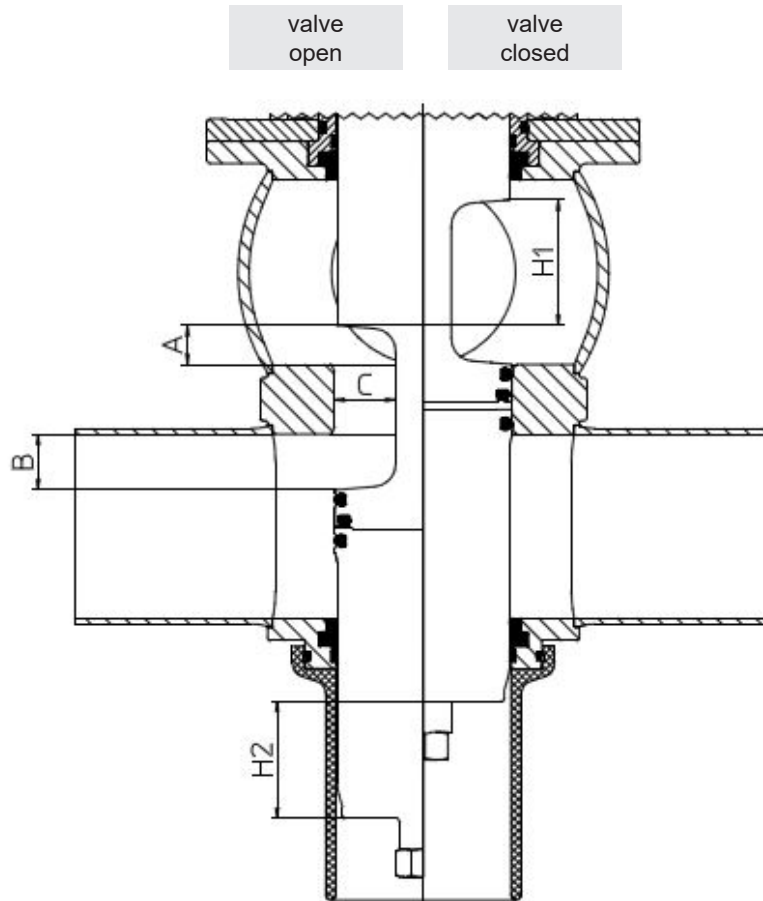

D4 Valve: Dimensions in IN					
Size	A	B	C	stroke H1 upper shaft	stroke H2 lower shaft
1.5"	0.23	0.27	0.87	1.25	1.14
2"	0.51	0.47	0.87	1.45	1.33
2.5"	0.60	0.78	0.87	1.77	1.65
3"	1.09	0.78	0.87	1.77	1.65
4"	1.92	0.98	1.42	1.96	1.85
6"	3.07	1.57	2.08	2.56	2.44

D4 SL Valve: Dimensions in IN					
Size	A	B	C	stroke H1 upper shaft	stroke H2 lower shaft
1.5"	0.15	0.15	0.87	1.14	1.02
2"	0.35	0.35	0.87	1.33	1.22
2.5"	0.56	0.55	0.87	1.53	1.41
3"	0.82	0.78	0.87	1.77	1.65
4"	1.69	0.98	1.42	1.96	1.85
6"	3.07	1.57	2.08	2.56	2.44

10. Maintenance



Note!

The maintenance intervals are different depending on the application and must be determined by the operator performing regular checks.

- Compressed air is not required to remove the valve.



Caution!

Do not clean the valve with products containing abrasive or polishing substances. Abrasive and polishing agents are especially harmful to the upper and lower shaft.



Required tools for standard maintenance:

- 1 x wrench SW13, SW24, SW30, SW32
- 1 x wrench SW36
- 2 x wrench SW17
- 1 x Allen key SW3, SW6
- long hook with 45° tip or long nose pliers
- pick tool for O-ring and rubber seal removal
- double joint forceps
- assembly stick D4 for assembly of lower shaft seal, see page 23
- disassembly and assembly tool for lower shaft seal, see page 23
- assembly tool for middle seal, see page 24
- assembly tool for seat seals, see page 25
- 2 long M8 hex screws for safe removal of valve insert
- For valve maintenance SPX FLOW offers complete seal kits (see spare parts lists).



Caution!

The use of seal materials being compatible with the product, application and CIP liquids must be ensured. In case of doubt, contact your local SPX FLOW representative.

- For seal replacement instructions, see section 11.2 to 11.3.
- Provide all seals with a thin layer of grease before their installation!
Recommendation:
Assembly grease for EPDM, HNBR and FPM (Viton)
0.75 kg/tin - Part no. H147382
60 g/tube - Part no. H147381
- Provide all screws and threaded parts with grease before their installation.
Recommendation: Klüber paste UH1 84-201
60 g/tube - Part no. H147379
Recommendation for actuator:
Pneumatic grease:
25 ml/tube - Part no. H164725
- For valve assembly instructions, see section 11.3.

11. Service Instructions

The item numbers refer to the spare parts drawings

D4 1,5"-4", DN40-100	RN 500.047.01
D4 6", DN125-150	RN 500.047.03
D4 SL 1,5"-4", DN40-100	RN 501.047.01
D4 SL 6", DN125-150	RN 501.047.03

fig. 11.1.

For the Disassembly/Assembly tools, see chapter 13.

11.1. Removal from the line system



Caution!

1. Shut off the line pressure in the product and cleaning lines, and discharge the pipes if possible.
2. Remove the compressed air lines from the valve actuator (17).
3. Release the 2 screws at the clamp rings and lift the control unit off the adapter.
4. Design with proximity switch holder:
Release the screws at the proximity switch holder and lift off the proximity switch holder.
5. Remove the flange screws (27) in the yoke (6). For additional safety, replace two flange screws with longer screws that are partially threaded into the flange. Once these longer screws are in place, the other two flange screws can be safely removed.
6. Screw one flange screw (27) into the threaded bore of the yoke (6) to lift the complete valve insert. Do not remove the screw. It helps to re-install the valve insert.
7. Carefully lift the valve insert vertically out of the valve housing (1).

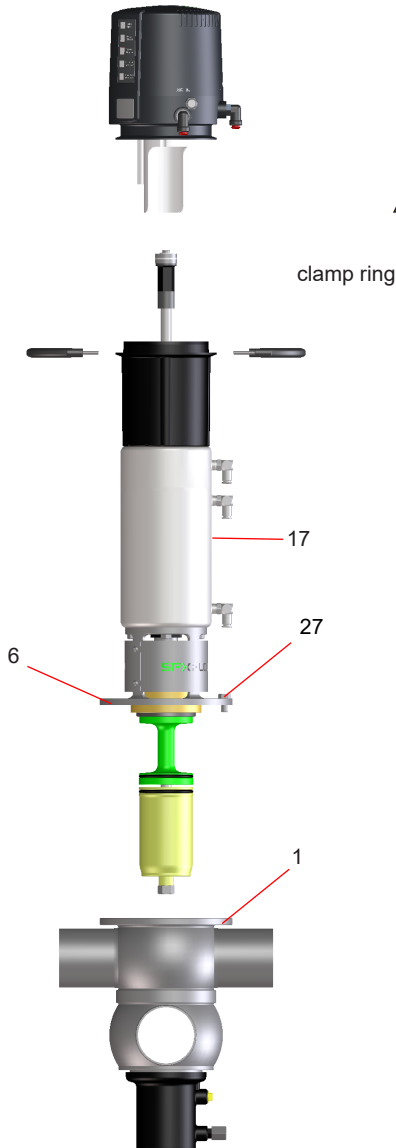

11. Service Instructions

fig. 11.2.

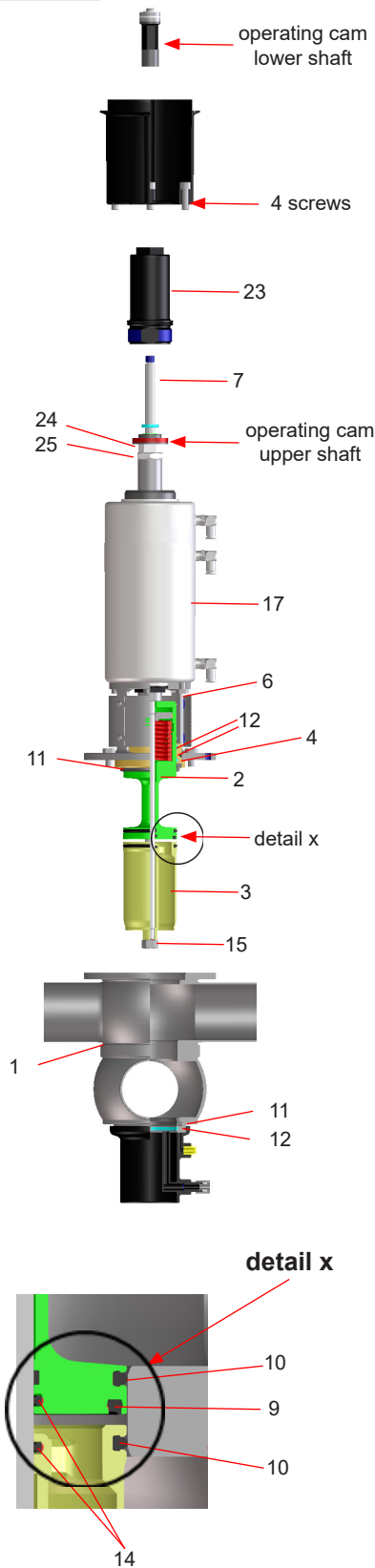

For the Disassembly/Assembly tools, see chapter 13.

11.2. Removal of product-wetted parts

1. Remove the operating cam from the guide rod (7).
2. In order to take off the adapter, remove the 4 screws.
3. Release the lower safety nut (15). Hold the lower shaft (3) with an SW17 wrench to keep it from turning.
4. After removing the nut (15), lift off the lower shaft (3).
5. Place the point of the tool along the side of the seat seal (10) and pull it out of the groove. Take the quad ring (14) out of the groove.
6. Remove the stop screw (23).
7. Take the guide rod (7) out through the top of the actuator.
8. Remove the operating cam at the upper shaft.
9. Unscrew the safety nut (24). Hold up the lock washer (25) with a SW30 key to keep it from turning. Remove the lock washer.
10. Lift off the actuator (17) with yoke (6).
11. Slide the shaft bearing (4) over the balancer of the upper valve shaft (2).
12. Remove the shaft seal (11), 6", DN125/150 also (11.1), and guide rings (12) from the grooves.
13. Removing the seals in the upper shaft
Place the point of the tool along the side of the seat seal (10) and middle seal (9) and pull them out of the groove. Take the quad ring (14) out of the groove.
14. Removing the lower shaft seal from the housing
Place the point of the disassembly tool along the side of the shaft seal (11) and pull it out through the top of the housing (1).
15. Only applies for sizes 1,5"-4", DN40-100: Place the metal point of a hook in the gap of the guide ring (12). Slightly turn the hook to lift the guide ring (12) out of the groove and housing (1).

11. Service Instructions

fig. 11.3.

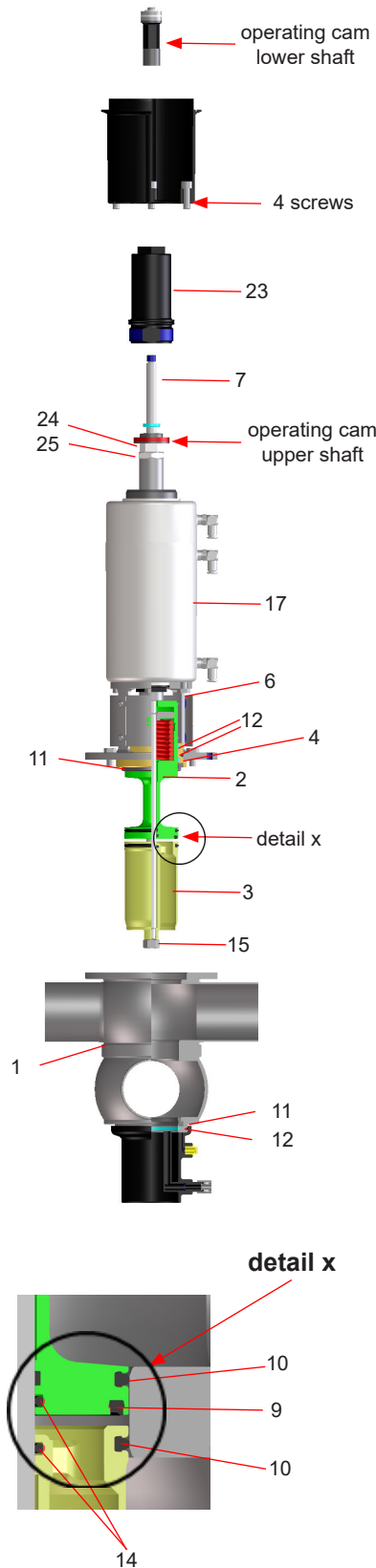

For the Disassembly/Assembly tools, see chapter 13.

11.3. Installation of product-wetted seals and assembly of the valve



Note!

Make sure that all seals and bearing surfaces in the product area are slightly greased before their installation.

1. Only applies for sizes 1,5"-4", DN40-100: Install the guide ring (12) in the lower flange of the housing (1) using a double joint forceps or long nose pliers.
2. Install the lower shaft seal (11), 6", DN125/150 also (11.1), in the lower housing flange. For the small size, we recommend using the 2 insertion tools, see chapter 13.
3. Install the quad ring (14) in the upper shaft (2) and lower shaft (3).
4. Insert the middle seal (9) in the upper shaft (3) using the assembly tool (see chapter 13.2).
5. Insert the 2 seat seals (10) in the grooves of the upper shaft (2) and lower shaft (3).
6. Install the shaft seal (11) and the two guide rings (12) in the shaft bearing (4).
7. Slide the shaft bearing (4) over the balancer of the upper shaft (2).
8. Slide the upper shaft (2) and the shaft bearing (4) through the yoke (6) and actuator (17).
9. Align key and fasten the upper valve shaft (2) with the lock washer (25) and safety nut (24). Hold the lock washer (25) with a SW30 wrench to keep the lock washer from turning. Tightening torque: 7 ft-lb (40 Nm)



Caution!

Overtightening of the safety nut could result in thread damage on the upper shaft.

10. Screw the operating cam on the upper shaft.
11. Ensure the key is secure on the guide rod. Slide in the guide rod (7) from the top through the actuator (17) until it stops.
12. Screw in the stop screw (23) until it stops. Tightening torque: 7 ft-lb (10 Nm)
The stop screw must be flush with the top of the collar (D4) or piston (D4 SL).
13. Slide the lower valve shaft (3) on the guide rod (7). Align the lower shaft to the key on the guide rod and fasten it with the safety nut (15). Tightening torque: 29 ft-lb (40 Nm)
14. Fasten the adapter on the actuator with the 4 screws and ensure that the air fittings on the CU will align properly with the air fittings on the D4 valve.
15. Screw the operating cam on the guide rod (7).

11. Service Instructions

fig. 11.4.

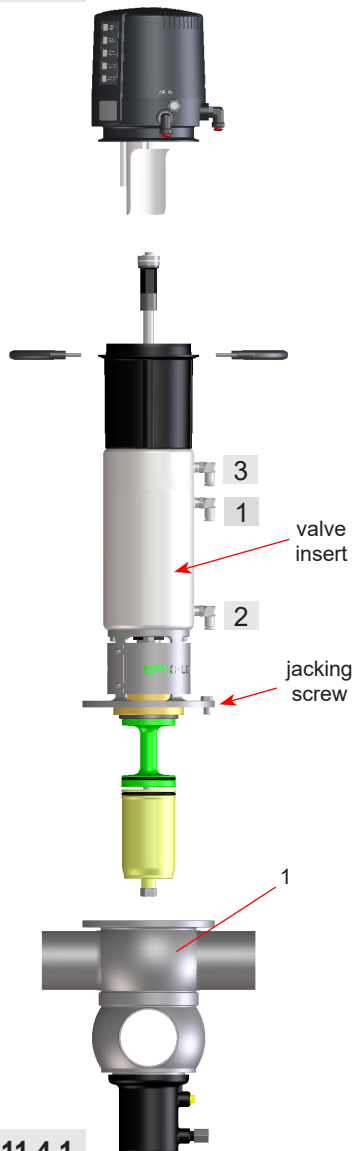

The item numbers refer to the spare parts drawings
 Inch and DIN designs: D4 RN 500.047.01;
 Inch and DIN designs: D4 SL RN 501.047.01

11.4. Installation of the valve insert

1. Carefully place the valve insert in the valve housing (1) until the screw stops.
2. Remove the jacking screw and carefully press the valve insert into the housing (1).
3. Screw in the hex. screws (27) and fasten them crosswise.
4. Place the control unit on the adapter. Make sure that the control unit is centered on the adapter.
5. Place the clamp ring and fasten it with the screws.
6. Assemble the compressed air lines.
D4 Valve: Air connection 1: to open valve
D4 SL Valve: Air connection 1: to open valve
 Air connection 2: to lift upper shaft
 Air connection 3: to lift lower shaft
7. Check the valve position indicators:

Closed valve position feedback – sensor 1 controlled

To adjust Hall sensor 1, ensure that the valve is in the closed position, the solenoid / manual override are not activated. Turn adjustment screw 1 into the required position. The LED "Valve Closed" lights up.

Open valve position feedback – sensor 2 controlled

To adjust Hall sensor 2, first activate the solenoid valve 1, either manually or electrically. Then turn adjustment screw 2, to adjust the open valve position and the corresponding feedback. When it reaches the required position, the LED "Valve Open" lights up.

fig. 11.4.1.

D4 / D4 SL with valve position indication

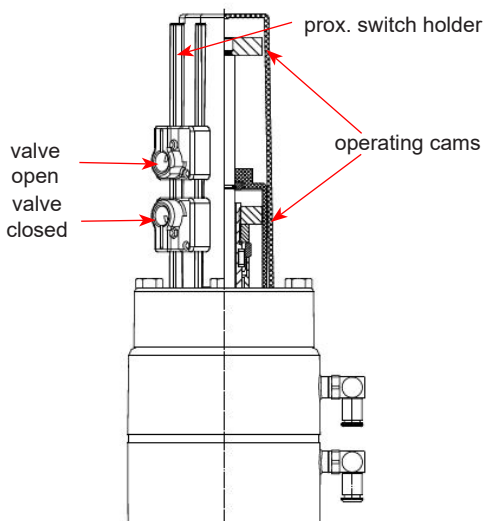

Observe the switching hysteresis of the Hall effect sensors!
 Therefore, adjust the switch point of the sensors with overlap in order to permit small variations. We recommend additional 2 x 360° turns of the adjustment screw.

8. Design with proximity switch holder:
 Set the proximity switch holder in position and fasten it with the screws. Check to see if the "Valve Closed" or "Valve Open" message appears. Re-position the proximity switch if required.

12. Maintenance of Actuator

fig. 12.: D4 Valve actuator

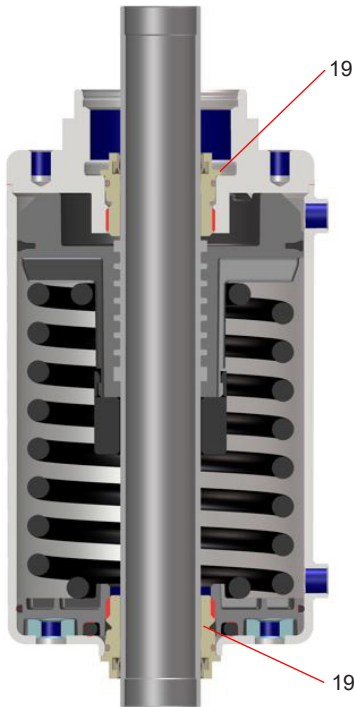

The item numbers refer to the spare parts drawings

D4 1,5"-4", DN40-100	RN 500.047.01
D4 6", DN125-150	RN 500.047.03
D4 SL 1,5"-4", DN40-100	RN 501.047.01
D4 SL 6", DN125-150	RN 501.047.03

12.1 Removing the actuator screws

1. Remove yoke cover and yoke.
2. Unscrew the two actuator screws (19) with a SW36 socket wrench.
3. Remove the V-seals (20) and O-rings (18).

12.2 Installing the seals and assembling the actuator

1. Install the slightly greased O-rings (18) and V-seals (20) in the actuator screws (19). Check the correct installation position of the V-seal (20).

Recommendation for actuator:

Pneumatic grease
25 ml /tube - Part no. H164725

2. Place the assembly tool (H338580) on the end of the piston rod. Screw the actuator screws (19) with a socket wrench SW36 over the piston rod at both sides of the actuator and fasten them.
3. Re-install yoke and yoke cover.

fig. 12.: D4 SL Valve actuator

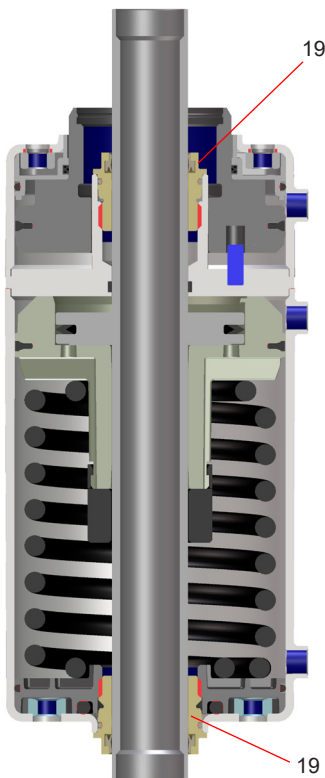

Actuator screw

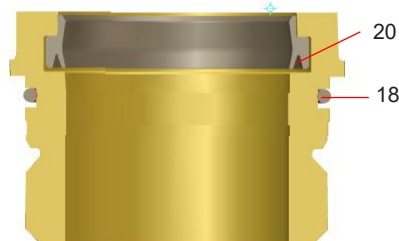

Assembly tool for actuator screw (H338580)



13. Assembly Instructions and Tools for Seals

**Assembly tool
(H171889)**

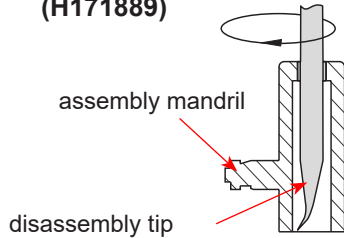

**Assembly stick
(H338450)**

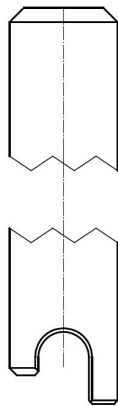

13.1. Lower shaft seal

For the simple assembly of the lower shaft seal (11), the assembly/disassembly tool (H171889) and the assembly stick (H338450) can be used. These tools are especially recommended for valves of small series (1.5"-3"; DN40-65) as access to the lower shaft seal from the top is impossible as a result of the narrow seat.



Caution!

To avoid injuries the disassembly tip must be covered by the assembly mandril if not used.

1. Slightly grease the shaft seal (11).
2. Use the assembly tool to insert the shaft seal from the top, the wide side to the front, through the intermediate ring of the housing into the lower flange housing ball (fig 1.).
3. Position the shaft seal (11) using the groove of the assembly mandril.
4. Press the shaft seal (11) at one spot in the groove of the housing flange and continue to press on the shaft seal.
5. Position the groove of the assembly stick on the seal lip. Slightly turn the stick and position the shaft seal (11) in the groove. Slide further around the seal lip and insert the shaft seal in a similar manner until the shaft seal is completely in the groove.

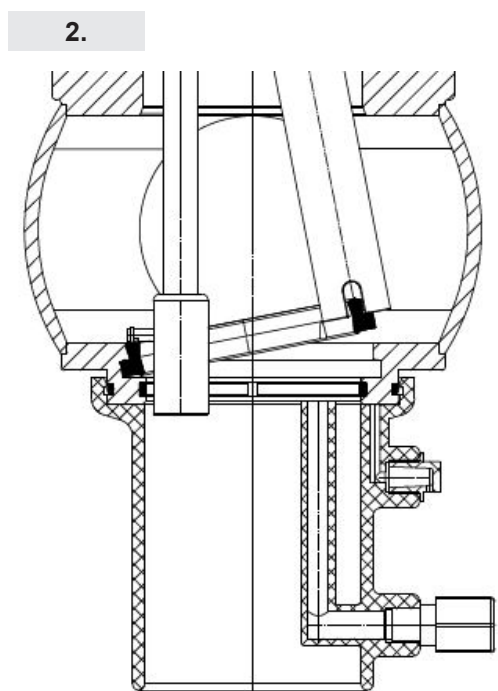
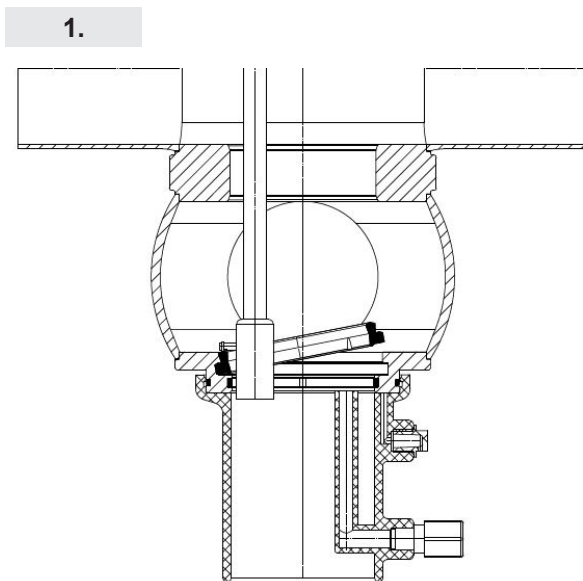

13. Assembly Instructions and Tools for Seals

13.2. Middle seal

The assembly tool consists of:

- nut
- thrust ring
- ring with venting tip
- housing
- threaded bolt

Installation of the middle seal in the valve shaft

1. Insert the valve shaft into the housing making sure that the seal groove is in the housing.
2. Use the threaded bolt to clamp the shaft into the housing. Clamp the housing into a vice.
3. Slightly grease the middle seal with assembly grease. Then install the seal on the ring.
4. Insert the ring with the installed seat seal into the housing. Make sure that the venting tip is positioned in the seal groove.
5. Insert the thrust ring around the ring in the housing. Screw on the nut and tighten it with a hook spanner until it stops.
6. Release the nut. Take the ring and thrust ring off the housing.
7. Take the housing out of the vice. Take off the threaded bolt. Detach the valve shaft from the housing.

Make sure the middle seal fits evenly.

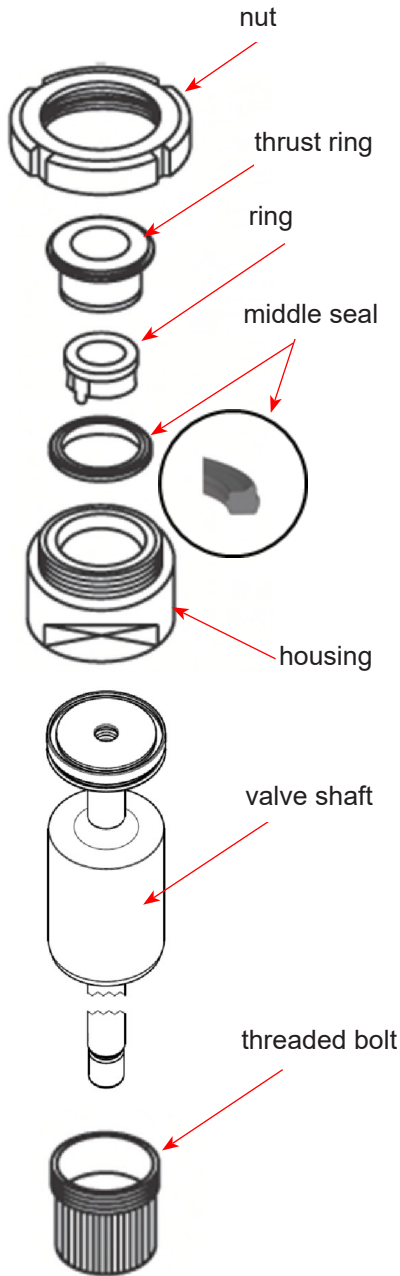

Assembly tool for middle seal

DN	Inch	Designation	Part no.
40	1.5"	DA3 - 62	H207310
50	2"		
65	2.5" 3"		
80	4"	DA3 - 92	H207311
100			
125		D4 - 114	H340758
150	6"	D4 - 138	H340823

13. Assembly Instructions and Tools for Seals

13.3. Seat seals

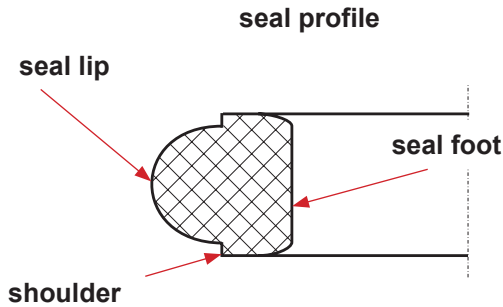

Attention!

Shoulders of the seat seals must be placed evenly in the seal groove.

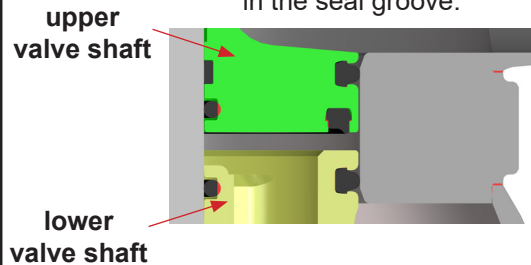

1. Provide the seal shoulder with a thin layer of grease.

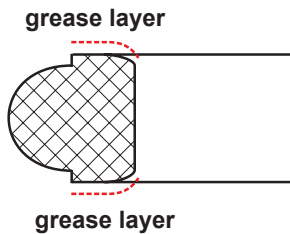

2. Insert the seat seal into the valve shaft; see to an even inclined position of the seal.

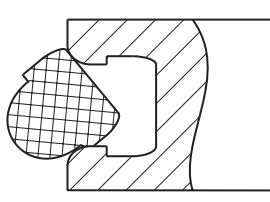

3. Press the seal circumferentially into the groove by means of an assembly tool (use screw driver with round edges). Place the assembly tool at the upper seal shoulder. To get an even fit of the seal, proceed step by step:

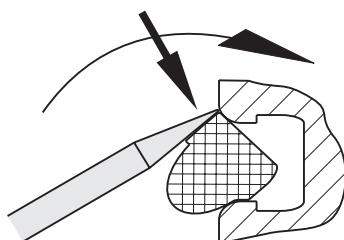

- 3.1. Press a short piece part of the seal into the groove.

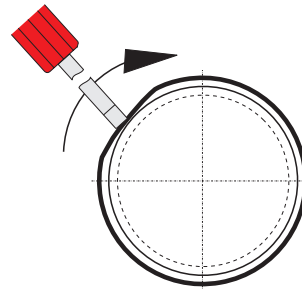

- 3.2. Fix the seal - already pressed in - by your finger (to prevent loops). Use the assembly tool to press a short part of the seal into finger direction. Install the seal in the groove circumferences.

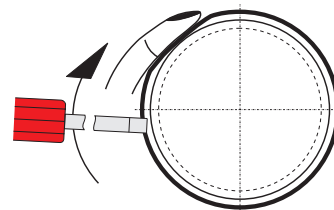

4. Press the assembly tool between the seal shoulder and the groove edge (both sides). Proceed around the circumferences. Then proceed around the circumferences of the lower seal shoulder. This is to vent the seal groove and to lock the seal shoulder.

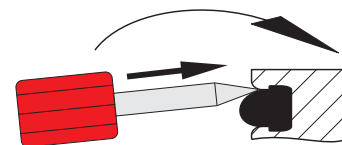

14. Trouble Shooting

Failure	Valve position		Required seal replacement
	closed	open	
Leakage at upper housing flange or yoke	x	x	upper shaft seal (11)
Leakage from the inside of the lower valve shaft	x		seat seals (10)
Leakage from the inside of the lower valve shaft		x	middle seal (9)
Leakage at the outside of the lower valve shaft (remove spray connection for this purpose)	x	x	lower shaft seal (11)

The position numbers refer to the spare parts drawings.

15. Spare Parts Lists

The reference numbers of the spare parts for the different valve designs and sizes are included in the attached spare parts drawings with corresponding lists.

Please consider that the spare parts lists for the **D4 valve** and the **D4 SL valve** - respectively standard and large sizes - are different. You find **four separate lists** in the annex to this instruction manual.

Please indicate the following data to place an order for spare parts:

- number of required parts
- reference number
- designation.

Data are subject to change.

Information contained in this document is subject to change without notice and does not represent a commitment on the part of SPX FLOW, Inc.. No part of this document may be reproduced or transmitted in any form or by any means, electronic or mechanical, including photocopying and recording, for any purpose, without the express written permission of SPX FLOW, Inc..

Spare Parts List

Double seat mix proof valve D4 1.5" - 4" ; DN 40 - 100

Date:	16.3.18	30.10.18	SPX FLOW			
Name:	C. Keil	C. Keil				
Reviewed:						
Date:			Page	1	of	9
Name:			RN 500.047.01			
Reviewed:						

Pos:34/35 please refer to CU4 manual

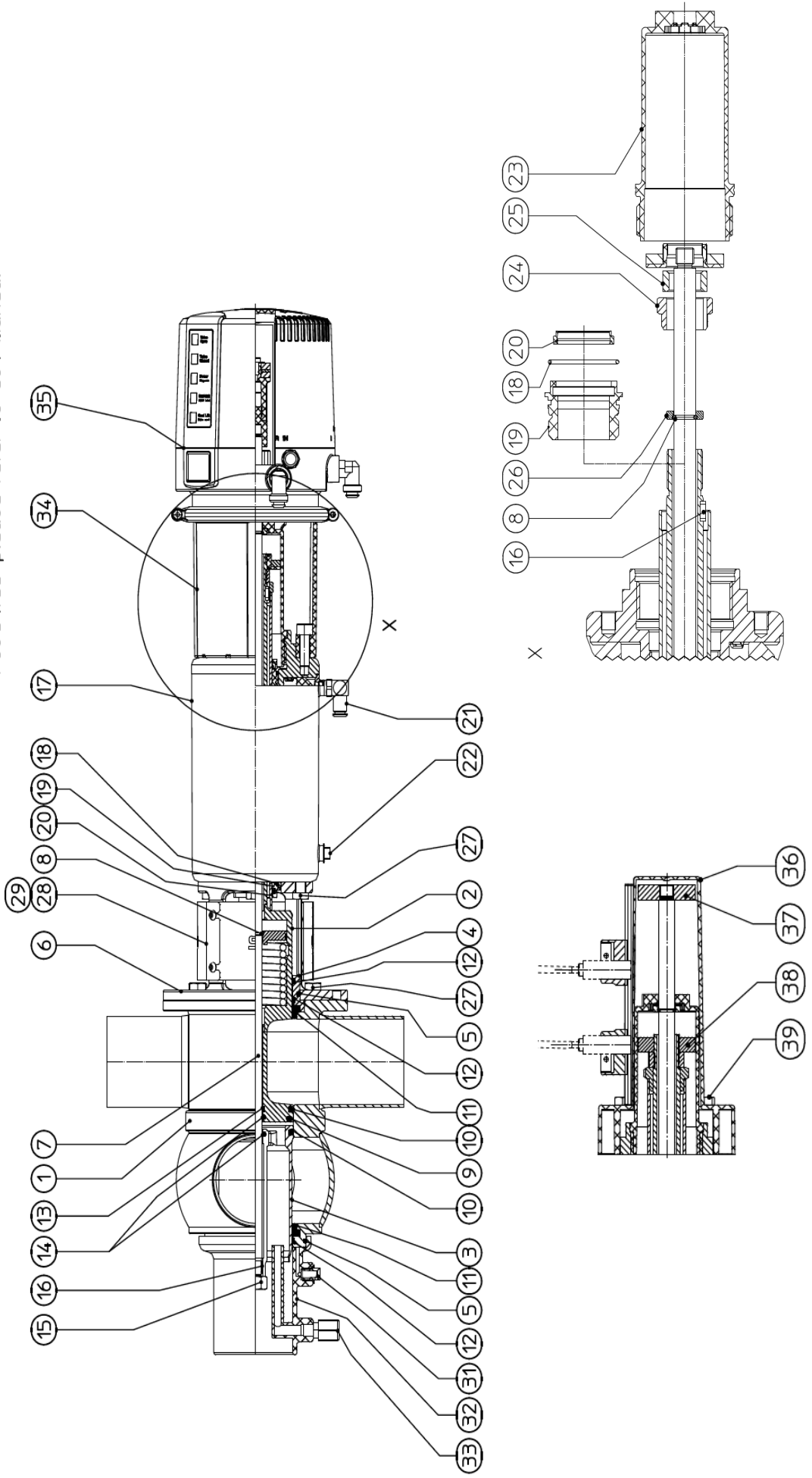

Information contained in this document is subject to change without notice and does not represent a commitment on the part of SPX FLOW, Inc.. No part of this document may be reproduced or transmitted in any form or by any means, electronic or mechanical, including photocopying and recording, for any purpose, without the express written permission of SPX FLOW, Inc..

Spare parts list

Double seat mix proof valve D4 1.5" - 4"; DN 40 - 100

Pos. Item	Quantity	Description	included in spare parts (pos.)	Material	DN40	1.5"	DN50	2"	DN65	SPX FLOW	
					Reference no. Part no.	Reference no. Part no.	Reference no. Part no.	Reference no. Part no.	Reference no. Part no.	Reference no. Part no.	
	2	Seat seal		EPDM			000 58-33-132/93 H168192				
10	2	Seat seal		HNBR			000 58-33-132/33 H171561				
	2	Seat seal		FPM			000 58-33-132/73 H171559				
	2	Shaft seal		EPDM			000 58-33-400/93 H337476				
11	2	Shaft seal		HNBR			000 58-33-400/33 H337478				
	2	Shaft seal		FPM			000 58-33-400/73 H337477				
12	3	Guide ring		Iglidur A500			000 58-01-610/99 H334863				
13	1	Guide band		Acoflon			000 08-39-380/99 H334865				
14	1	Quad ring 12,37x 2,62		EPDM			000 58-01-049/63 H311646				
15	2	Hex. Screw M10x1		A2			000 65-50-087/15 H118903				
16	2	Square key DIN6885 - A - 3x3x10		A2			000 29-02-190/17 H335171				
17	1	Actuator	18, 19, 20	1.4301	000 29-02-178/17 H335446		000 29-02-179/17 H335443		000 29-02-180/17 H334365		
18	2	O-ring 30 x 2,5		NBR			000 58-06-113/83 H337897				
19	2	Actuator screw		Iglidur J350			000 16-28-330/93 H334376				
20	2	V-seal		NBR			000 58-01-600/73 H334379				

Information contained in this document is subject to change without notice and does not represent a commitment on the part of SPX FLOW, Inc.. No part of this document may be reproduced or transmitted in any form or by any means, electronic or mechanical, including photocopying and recording, for any purpose, without the express written permission of SPX FLOW, Inc..

Spare parts list

Double seat mix proof valve D4 1.5" - 4" ; DN 40 - 100

Pos. Item	Quantity	Description	included in spare parts (pos.)	Material	DN40	1.5"	DN50	2"	DN65	SPX FLOW	
					Reference no. Part no.	Reference no. Part no.	Reference no. Part no.	Reference no. Part no.	Reference no. Part no.	Reference no. Part no.	Page 4 of 9
21	3	W-union G1/8" Ø6mm		hard nickel-plated			000 08-60-750/93 H208825				
22	1	Venting plug G-1/8"		PE-Hard			000 08-60-005/93 H16218				
23	1	Stop screw		Grivory			000 16-28-340/39 H334382				
24	1	Lock washer D4		1.4301			000 67-03-030/12 H335172				
25	1	Safety nut D3		1.4301			000 65-50-137/15 H147640				
26	1	Thrust ring		1.4057			000 08-48-106/12 H123151				
27	8	Hex. screw M8 x 16		A2			000 65-01-081/15 H78772				
28	1	Yoke cover D4	29	1.4301			000 16-40-220/00 H341311				
29	4	Savetix head screw M4 x 8 washer M4 as set		1.4301			000 65-06-010/12 H336707				
30											
31	1	Venting plug G-1/8"		PE-Hard			000 08-74-014/93 H16507				
32	1	Spray connection DE3		PP			000 09-40-114/93 H168321				
33	1	G-union 8x1-G1/8"		PVDF-black			000 08-63-003/13 H16388				
34	1	CU4 D4 adapter cmpl.		PA6.6 GF30 black			000 08-46-646/93 H337098				
	1	CU4plus D4 V1 adapter cmpl.		PA6.6 GF30 black			000 08-46-666/93 H336441				

Information contained in this document is subject to change without notice and does not represent a commitment on the part of SPX FLOW, Inc.. No part of this document may be reproduced or transmitted in any form or by any means, electronic or mechanical, including photocopying and recording, for any purpose, without the express written permission of SPX FLOW, Inc..

Spare parts list

Double seat mix proof valve D4 1.5" - 4" ; DN 40 - 100

		Date:	16.3.18	07.10.19	21.08.20	SPX FLOW								
		Name:	C.Keil	Size-Si	C.Keil									
		Reviewed:												
		Date:				Page	5 of 9							
		Name:				RN 500.047.01								
		Reviewed:												
Pos.	Item	Quantity	Description	included in spare parts (pos.)	Material	DN40	1.5"	DN50	2"	DN65	Reference no.	Part no.	Reference no.	Part no.
		1	CU41 D4 DC ø6mm		PA 6.6 GF30 black			000 08-45-380/93 H336954						
		1	CU41 D4 M12 DC ø6mm		PA 6.6 GF30 black			000 08-45-570/93 H341342						
		1	CU41 D4 AS-i Ext. ø6mm		PA 6.6 GF30 black			000 08-45-382/93 H336956						
		1	CU41 D4 M12 AS-i Ext. ø6mm		PA6.6 GF30 black			000 08-45-386/93 H338878						
35		1	CU41 D4 AS-i Std. ø6mm		PA 6.6 GF30 black			000 08-45-384/93 H338150						
		1	CU41 D4 M12 AS-i Std. ø6mm		PA 6.6 GF30 black			000 08-45-388/93 H338898						
		1	CU41plus D4 V1 AS-i Ext. ø6mm		PA6.6 GF30 black			000 08-45-555/93 H338819						
		1	CU41plus D4 V1 M12 AS-i Ext. ø6mm		PA6.6 GF30 black			000 08-45-339/93 H338864						
36		1	Prox. switch holder D4 compl.		PA 6.6 GF30 black			000 16-33-050/93 H336751						
37		1	Operating cam D4 bottom		1.4523 / 444FR			000 08-60-461/99 H334386						
38		1	Operating cam D4 top		1.4523 / 444FR			000 08-60-460/99 H334387						
39		4	Hex. screw M8x40		A2-70			000 65-01-086/15 H336675						
Pos. 9, 10, 11, 12, 14 available as complete seal kits only														
		1	Seal kit		EPDM			000 58-38-005/01 H337884						
		1	Seal kit		FPM			000 58-38-005/00 H337886						
		1	Seal kit		HNBR			000 58-38-005/06 H337885						

Information contained in this document is subject to change without notice and does not represent a commitment on the part of SPX FLOW, Inc.. No part of this document may be reproduced or transmitted in any form or by any means, electronic or mechanical, including photocopying and recording, for any purpose, without the express written permission of SPX FLOW, Inc..

Spare parts list

Double seat mix proof valve D4 1.5" - 4"; DN 40 - 100

		Date: 20.3.18 07.10.19 21.08.20		SPX FLOW	
		Name: C. Keil		Page 9 of 9	
		Reviewed:		RN 500.047.01	
		Date:			
		Name:			
		Reviewed:			
		Date:			
		Name:			
		Reviewed:			
		Date:			
		Name:			
		Reviewed:			
		DN100	Reference no. Part no.	4"	Reference no. Part no.
		DN80	Reference no. Part no.		Reference no. Part no.
		3"	Reference no. Part no.		Reference no. Part no.
Pos.	Item	Description	included in spare parts (pos.)	Material	Quantity
	1	CU41 D4 DC ø6mm		PA 6.6 GF30 black	
	1	CU41 D4 M12 DC ø6mm		PA 6.6 GF30 black	
	1	CU41 D4 AS-i Ext. ø6mm		PA 6.6 GF30 black	
	1	CU41 D4 M12 AS-i Ext. ø6mm		PA6.6 GF30 black	
	1	CU41 D4 AS-i Std. ø6mm		PA 6.6 GF30 black	
	1	CU41 D4 M12 AS-i Std. ø6mm		PA 6.6 GF30 black	
	1	CU41plus D4 V1 AS-i Ext. ø6mm		PA6.6 GF30 black	
	1	CU41plus D4 V1 M12 AS-i Ext. ø6mm		PA6.6 GF30 black	
35	1	Prox. switch holder D4 compl.		PA 6.6 GF30 black	
36	1	Operating cam D4 top		1.4523 / 444FR	
37	1	Operating cam D4 bottom		1.4523 / 444FR	
38	1	Operating cam D4 top		1.4523 / 444FR	
Pos. 9, 10, 11, 12, 14 available as complete seal kits only					
	1	Seal kit		EPDM	
	1	Seal kit		FPM	
	1	Seal kit		HNBR	

Information contained in this document is subject to change without notice and does not represent a commitment on the part of SPX FLOW, Inc.. No part of this document may be reproduced or transmitted in any form or by any means, electronic or mechanical, including photocopying and recording, for any purpose, without the express written permission of SPX FLOW, Inc..

Spare Parts list

**Double seat mix proof valve
D4 - 125-150-6"**

Date:	11.10.19	10.06.20	20.06.23
Name:	Sze-Si	C.Keil	C.Keil
Reviewed:			

Date:			
Name:			
Reviewed:			

SPX FLOW

Page 1 of 5

RN 500.047.03

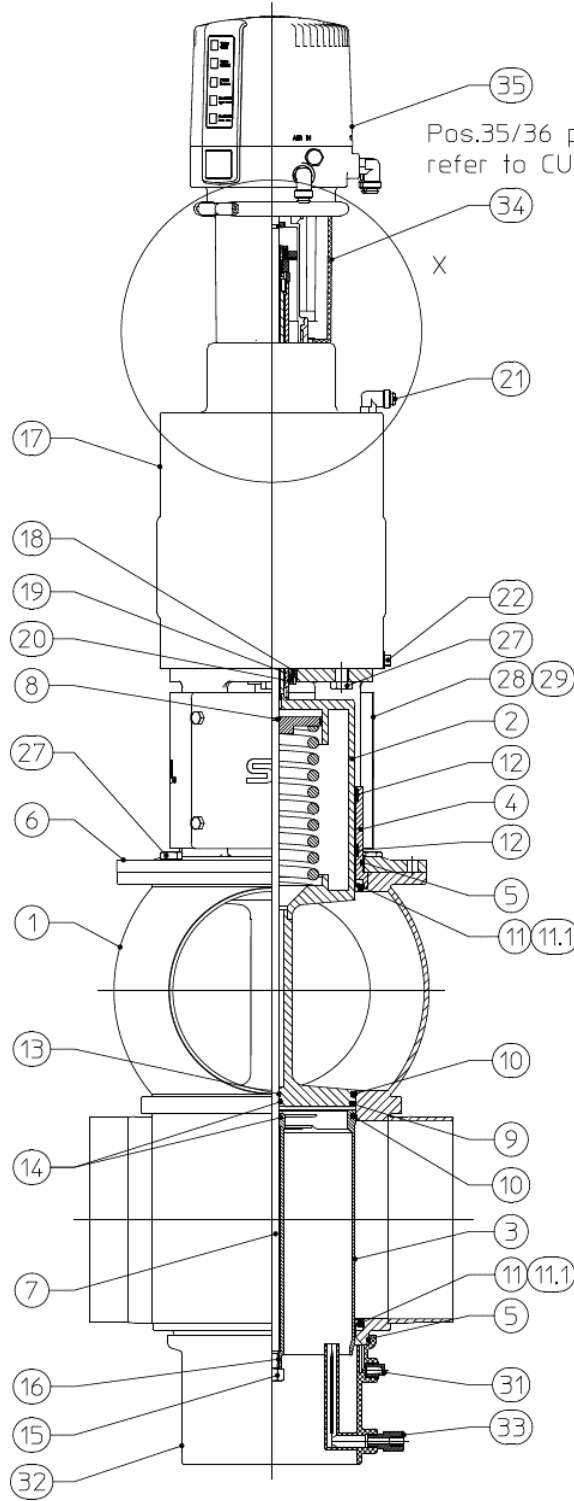

Pos.35/36 please refer to CU4 manual

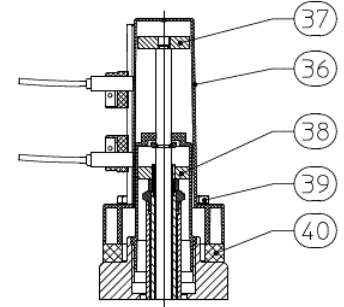

Detail X

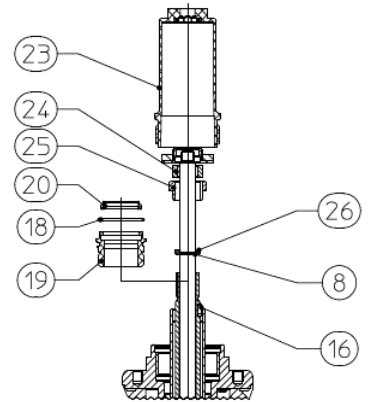

Information contained in this document is subject to change without notice and does not represent a commitment on the part of SPX FLOW, Inc.. No part of this document may be reproduced or transmitted in any form or by any means, electronic or mechanical, including photocopying and recording, for any purpose, without the express written permission of SPX FLOW, Inc..

Spare Parts list

**Double seat mix proof valve
D4 - 125-150-6"**

		Date: 11.10.19								SPX FLOW	
		Name: Sze-Si.								Page 2 of 5	
		Reviewed:								RN 500.047.03	
Pos.	Qty.	Description	Material	DN125 Reference no. Part no.	DN150 Reference no. Part no.	6" Reference no. Part no.					
1	1	Housing D41 / 1-6	1.4404	000 16-61-687/47 H340122	000 16-61-737/47 H340135	000 16-61-762/47 H340141					
	1	Housing D41 / 1-7	1.4404	000 16-61-697/47 H340123	000 16-61-747/47 H340136	000 16-61-772/47 H340142					
	1	Housing D41 / 1-8	1.4404	000 16-61-691/47 H340124	000 16-61-741/47 H340137	000 16-61-766/47 H340143					
	1	Housing D42	1.4404	000 16-62-697/47 H340121	000 16-62-747/47 H340134	000 16-62-772/47 H340140					
2	1	Housing D43	1.4404	000 16-63-697/47 H340120	000 16-63-747/47 H340133	000 16-63-772/47 H340139					
	1	Housing D44	1.4404	000 16-64-697/47 H340119	000 16-64-747/47 H340132	000 16-64-772/47 H340138					
3	1	Upper valve shaft 13, 16, 25	1.4404	000 16-25-694/00 H341269	000 16-25-234/00 H341270	000 16-25-520/42 H340311					
4	1	Lower valve shaft	1.4404	000 16-25-689/42 H340230	000 16-25-520/42 H340311	000 16-28-303/12 H340322					
5	2	Shaft bearing	EPDM	000 58-06-555/63 H77074	000 58-06-655/63 H77081	000 58-06-655/63 H77081					
6	1	O-ring	1.4301	000 16-40-202/12 H340244	000 16-40-202/12 H340323	000 16-40-204/12 H340323					
7	1	Yoke	1.4404	000 16-25-687/00 H341298	000 16-25-687/00 H341298	000 16-25-545/00 H341299					
8	2	Guide rod 8, 15, 16	1.4310	08-39-083/13 H14883	08-39-083/13 H14883	000 16-25-545/00 H341299					
9	1	Retainer ring	EPDM	000 58-33-996/93 H340247	000 58-33-996/93 H340325	000 58-33-995/93 H340325					
	1	Middle seal	HNBR	000 58-33-996/33 H340248	000 58-33-996/33 H340326	000 58-33-995/33 H340326					
	1	Middle seal	FFM	000 58-33-996/73 H340294	000 58-33-996/73 H340327	000 58-33-995/73 H340327					

Information contained in this document is subject to change without notice and does not represent a commitment on the part of SPX FLOW, Inc.. No part of this document may be reproduced or transmitted in any form or by any means, electronic or mechanical, including photocopying and recording, for any purpose, without the express written permission of SPX FLOW, Inc..

Spare Parts list

**Double seat mix proof valve
D4 - 125-150-6"**

pos. item	Quantity	Description	included in spare parts (pos.)	Material	125 Reference no. Part no.	150 Reference no. Part no.	6" Reference no. Part no.	Date: 11.10.19 Name: Sze-Si. Reviewed:	Date: 11.10.19 Name: Sze-Si. Reviewed:	Page 3 of 5	SPX FLOW
10	2	Seat seal		EPDM	000 58-33-135/93 H173940	000 58-33-134/93 H173739					
	2	Seat seal		HNBR	000 58-33-135/33 H173939	000 58-33-134/33 H173738					
	2	Seat seal		FPM	000 58-33-135/73 H340246	000 58-33-134/73 H338070					
	2	Shaft seal		EPDM	000 58-33-693/93 H77611	000 58-33-743/93 H77628					
11	2	Shaft seal		HNBR	000 58-33-693/33 H170178	000 58-33-743/33 H170177					
	2	Shaft seal		FPM	000 58-33-693/73 H77610	000 58-33-743/73 H77627					
11.1	2	PTFE Shaft seal		PTFE	000 58-33-156/23 H340295	000 58-33-157/23 H340328					
12	2	Guide ring		Iglidur A500	000 58-01-614/99 H340198	000 58-01-613/99 H340182					
13	1	Guide band		Acoflon		000 08-39-380/99 H334865					
14	2	Quad ring 12,37x 2,62		EPDM		000 58-01-049/63 H311646					
15	2	Hex. Screw M10x1		A2		000 65-50-087/15 H118903					
16	2	Square key DIN6885 - A - 3x3x10		A2		000 29-02-190/17 H335171					
17	1	Actuator	18, 19, 20	1.4301	000 29-02-202/17 H340639	000 29-02-201/17 H340636					
18	2	O-ring 30 x 2,5		NBR		000 58-06-113/83 H337897					
19	2	Actuator screw		Iglidur J350		000 16-28-330/93 H334376					
20	2	V-seal		NBR		000 58-01-600/73 H334379					

Information contained in this document is subject to change without notice and does not represent a commitment on the part of SPX FLOW, Inc.. No part of this document may be reproduced or transmitted in any form or by any means, electronic or mechanical, including photocopying and recording, for any purpose, without the express written permission of SPX FLOW, Inc..

Spare Parts list		Date: 11.10.19 10.06.20			Name: C.Keil		Reviewed:		SPX FLOW	
Double seat mix proof valve D4 - 125-150-6"		Date: 11.10.19 10.06.20			Name: C.Keil		Reviewed:		Page 4 of 5	
Double seat mix proof valve D4 - 125-150-6"		Date: 11.10.19 10.06.20			Name: C.Keil		Reviewed:		RN 500.047.03	
pos. item	Quantity	Description	included in spare parts (pos.)	Material	Reference no. Part no.	Reference no. Part no.	Reference no. Part no.	Reference no. Part no.	Reference no. Part no.	Reference no. Part no.
21	1	W-union G1/8" Ø6mm		hard nickel-plated	000 08-60-750/93 H208825					
22	1	Venting plug G-1/8"		PE-Hard	000 08-60-005/93 H16218					
23	1	Stop screw		Grivory	000 16-28-340/39 H334382					
24	1	Safety nut D3		1.4301	000 65-50-137/15 H147640					
25	1	Lock washer D4		1.4301	000 67-03-030/12 H335172					
26	1	Thrust ring		1.4057	000 08-48-106/12 H123151					
27	8	Hex. screw M10 x 20		A2	000 65-01-134/13 H340472					
28	1	Yoke cover D4	29	1.4301	000 16-40-226/00 H341313	000 16-40-227/00 H341314				
29	4	Savetix head screw M6 x 8 washer M6 as set		1.4301	000 65-06-011/12 H340632					
30										
31	1	Venting plug G-1/8"		PE-Hard	000 08-74-014/93 H16507					
32	1	Spray connection DE3		PP	000 09-40-117/93 H178450	000 09-40-118/93 H200320				
33	1	G-union 10/8-G1/4" with supp. Sleeve cpl.		1.4571	000 16-38-200/42 H329696					
34	1	CU4 D4 adapter cmpl.		PA6.6 GF30 black	000 08-46-646/93 H337098					
	1	CU4plus D4 V1 adapter cmpl.		PA6.6 GF30 black	000 08-46-666/93 H336441					

Information contained in this document is subject to change without notice and does not represent a commitment on the part of SPX FLOW, Inc.. No part of this document may be reproduced or transmitted in any form or by any means, electronic or mechanical, including photocopying and recording, for any purpose, without the express written permission of SPX FLOW, Inc..

Spare Parts List

Double seat mix proof valve D4 SL 1.5 " - 4"; DN 40 - 100

Date:	16.3.18	30.10.18	11.10.19
Name:	C. Keil	C. Keil	Sze-Si.
Reviewed:			

SPX FLOW

Page 1 of 9

RN 501.047.01

Pos: 34/35 please refer to CU4 manual

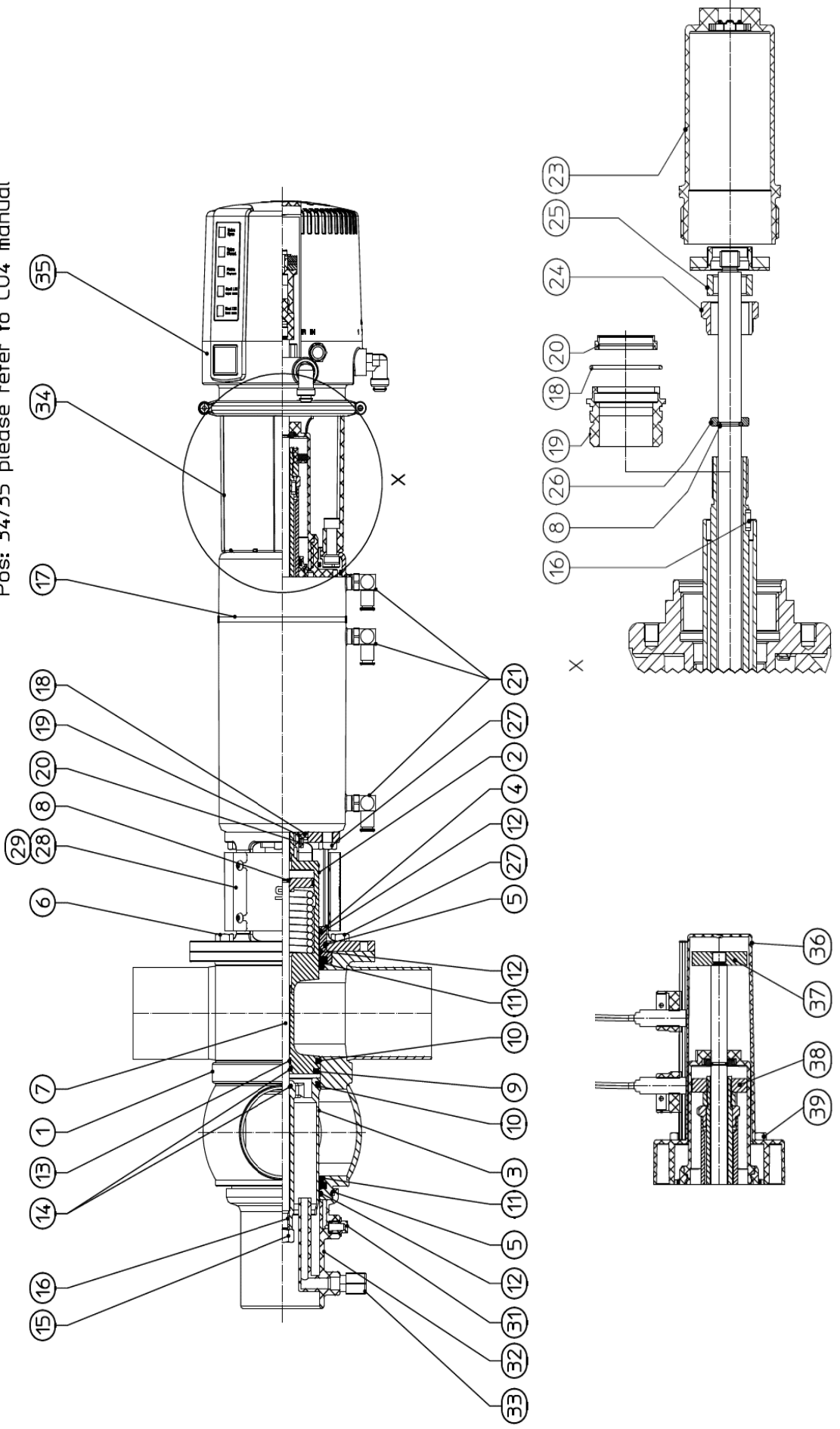

Information contained in this document is subject to change without notice and does not represent a commitment on the part of SPX FLOW, Inc.. No part of this document may be reproduced or transmitted in any form or by any means, electronic or mechanical, including photocopying and recording, for any purpose, without the express written permission of SPX FLOW, Inc..

Spare Parts List

Double seat mix proof valve D4 SL 1.5" - 4"; DN 40 - 100

Pos. Item	Quantity	Description	included in spare parts (pos.)	Material	DN40		1.5"		DN50		2"		DN65		2.5"	
					Reference no. Part no.	Reference no. Part no.	Reference no. Part no.	Reference no. Part no.	Reference no. Part no.	Reference no. Part no.	Reference no. Part no.					
1	1	Housing	D41 1-6	1.4404	000 16-61-387/47 H337180	000 16-61-412/47 H337185	000 16-61-437/47 H337181	000 16-61-462/47 H337186	000 16-61-487/47 H337182	000 16-61-512/47 H337187						
	1	Housing	D41 1-7	1.4404	000 16-61-397/47 H337170	000 16-61-422/47 H337175	000 16-61-447/47 H337171	000 16-61-472/47 H337176	000 16-61-497/47 H337172	000 16-61-522/47 H337177						
	1	Housing	D41 1-8	1.4404	000 16-61-391/47 H337190	000 16-61-416/47 H337195	000 16-61-441/47 H337191	000 16-61-466/47 H337196	000 16-61-491/47 H337192	000 16-61-516/47 H337197						
	1	Housing	D42	1.4404	000 16-62-397/47 H337023	000 16-62-422/47 H337028	000 16-62-447/47 H337024	000 16-62-472/47 H337029	000 16-62-497/47 H337025	000 16-62-522/47 H337030						
	1	Housing	D43	1.4404	000 16-63-397/47 H337033	000 16-63-422/47 H337038	000 16-63-447/47 H337034	000 16-63-472/47 H337039	000 16-63-497/47 H337035	000 16-63-522/47 H337040						
	1	Housing	D44	1.4404	000 16-64-397/47 H335273	000 16-64-422/47 H335272	000 16-64-447/47 H335274	000 16-64-472/47 H335271	000 16-64-497/47 H334443	000 16-64-522/47 H335270						
	2	1	Upper valve shaft	13, 16, 25	1.4404	000 16-25-391/00 H341262	000 16-25-441/00 H341263	000 16-25-491/00 H341264	000 16-25-516/00 H341265							
3	1	Lower valve shaft		1.4404	000 16-25-389/42 H334986	000 16-25-439/42 H334987	000 16-25-489/42 H334446									
4	1	Shaft bearing		1.4404	000 16-28-300/12 H334381											
5	2	O-ring		EPDM	000 58-06-295/64 H77039											
6	1	Yoke		1.4301	000 16-40-200/12 H334383											
7	1	Guide rod	8, 15, 16	1.4404	000 16-25-387/00 H341291	000 16-25-437/00 H341292	000 16-25-487/00 H341293	000 16-25-512/00 H341294								
8	2	Retainer ring		1.4310	000 08-39-083/13 H14883											
9	1	Middle seal		EPDM	000 58-33-998/93 H327602											
	1	Middle seal		HNBR	000 58-33-998/33 H332652											
	1	Middle seal		FPM	000 58-33-998/71 H332653											

Information contained in this document is subject to change without notice and does not represent a commitment on the part of SPX FLOW, Inc.. No part of this document may be reproduced or transmitted in any form or by any means, electronic or mechanical, including photocopying and recording, for any purpose, without the express written permission of SPX FLOW, Inc..

Spare Parts List

Double seat mix proof valve D4 SL 1.5 "- 4"; DN 40 - 100

Date:	16.3.18	11.10.19	SPX FLOW			
Name:	C. Keil	Size-Si.				
Reviewed:						
Date:			Page	3	of	9
Name:			RN 501.047.01			
Reviewed:						

Pos. Item	Quantity	Description	included in spare parts (pos.)	Material	DN40	1.5"	DN50	2"	DN65	Reference no. Part no.
					Reference no. Part no.	Reference no. Part no.	Reference no. Part no.	Reference no. Part no.		
	2	Seat seal		EPDM			000 58-33-132/93 H168192			
10	2	Seat seal		HNBR			000 58-33-132/33 H171561			
	2	Seat seal		FPM			000 58-33-132/73 H171559			
	2	Shaft seal		EPDM			000 58-33-400/93 H337476			
11	2	Shaft seal		HNBR			000 58-33-400/33 H337478			
	2	Shaft seal		FPM			000 58-33-400/73 H337477			
12	3	Guide ring		Iglidur A500			000 58-01-610/99 H334863			
13	1	Guide band		Acoflon			000 08-39-380/99 H334865			
14	1	Quad ring		EPDM			000 58-01-049/63 H311646			
15	2	Hex. screw M10x1		A2			000 65-50-087/15 H118903			
16	2	Square key		A2			000 29-02-190/17 H335171			
17	1	Actuator	18, 19, 20	1.4301			000 29-02-188/17 H335469		000 29-02-190/17 H334394	000 29-02-189/17 H335468
18	2	O-ring		NBR			000 58-06-113/83 H337897			
19	2	Actuator screw		Iglidur J350			000 16-28-330/93 H334376			
20	2	V-seal		NBR			000 58-01-600/73 H334379			

Information contained in this document is subject to change without notice and does not represent a commitment on the part of SPX FLOW, Inc.. No part of this document may be reproduced or transmitted in any form or by any means, electronic or mechanical, including photocopying and recording, for any purpose, without the express written permission of SPX FLOW, Inc..

Spare Parts List

Double seat mix proof valve D4 SL 1.5" - 4"; DN 40 - 100

Pos. Item	Quantity	Description	included in spare parts (pos.)	Material	DN40		1.5"		DN50		2"		DN65		Reference no. Part no.		Reference no. Part no.		
					Reference no. Part no.	Reference no. Part no.	Reference no. Part no.	Reference no. Part no.	Reference no. Part no.	Reference no. Part no.	Reference no. Part no.	Reference no. Part no.	Reference no. Part no.	Reference no. Part no.					
21	3	W-union G1/8" Ø6mm		hard nickel-plated															
23	1	Stop screw		Grivory															
24	1	Lock washer D4		1.4301															
25	1	Safety nut D3		1.4301															
26	1	Thrust ring		1.4057															
27	8	Hex. screw M8 x 16		A2															
28	1	Yoke cover D4	29	1.4301															
29	4	Savetix head screw M4 x 8 washer M4 as set		1.4301															
30																			
31	1	Venting plug G-1/8"		PE-Hard															
32	1	Spray connection DE3		PP															
33	1	G-union 8x1-G1/8"		PVDF-black															
34	1	CU4 D4 adapter cmpl.		PA6.6 GF30 black															
	1	CU4plus D4 V1 adapter cmpl.		PA6.6 GF30 black															

SPX FLOW

Information contained in this document is subject to change without notice and does not represent a commitment on the part of SPX FLOW, Inc.. No part of this document may be reproduced or transmitted in any form or by any means, electronic or mechanical, including photocopying and recording, for any purpose, without the express written permission of SPX FLOW, Inc..

Spare Parts List

Double seat mix proof valve D4 SL 1.5" - 4"; DN 40 - 100

		Date:	16.3.18	11.10.19	21.08.20	SPX FLOW						
		Name:	C. Keil	Size-Si.	C. Keil							
		Reviewed:										
		Date:				Page	5 of 9					
		Name:				RN 501.047.01						
		Reviewed:										
Pos.	Item	Quantity	Description	included in spare parts (pos.)	Material	DN40	1.5"	DN50	2"	DN65	Reference no. Part no.	Reference no. Part no.
		1	CU43 D4 DC ø6mm		PA 6.6 GF30 black			000 08-45-381/93 H336955				
		1	CU43 D4 M12 DC ø6mm		PA6.6 GF30 black			000 08-45-571/93 H341343				
		1	CU43 D4 AS-i Ext. Ø6mm		PA 6.6 GF30 black			000 08-45-383/93 H336957				
		1	CU43 D4 M12 AS-i Ext. ø6mm		PA6.6 GF30 black			000 08-45-387/93 H338897				
35		1	CU43 D4 AS-i Std. ø6mm		PA 6.6 GF30 black			000 08-45-385/93 H338152				
		1	CU43 D4 M12 AS-i Std. ø6mm		PA 6.6 GF30 black			000 08-45-391/93 H338899				
		1	CU43plus D4 V1 AS-i Ext. ø6mm		PA6.6 GF30 black			000 08-45-556/93 H338820				
		1	CU43plus D4 V1 M12 AS-i Ext. ø6mm		PA6.6 GF30 black			000 08-45-341/93 H338865				
36		1	Prox. switch holder D4 cmpl.		black			000 16-33-050/93 H336751				
37		1	Operating cam D4 bottom		1.4523 / 444FR			000 08-60-461/99 H334386				
38		1	Operating cam D4 top		1.4523 / 444FR			000 08-60-460/99 H334387				
39		4	Hex. screw M8x40		A2-70			000 65-01-086/15 H336675				
Pos. 9, 10, 11, 12, 14 available as complete seal kits only												
		1	Seal kit		EPDM			000 58-38-005/01 H337884				
		1	Seal kit		FPM			000 58-38-005/00 H337886				
		1	Seal kit		HNBR			000 58-38-005/06 H337885				

Information contained in this document is subject to change without notice and does not represent a commitment on the part of SPX FLOW, Inc.. No part of this document may be reproduced or transmitted in any form or by any means, electronic or mechanical, including photocopying and recording, for any purpose, without the express written permission of SPX FLOW, Inc..

Spare Parts List

Double seat mix proof valve D4 SL 1.5 " - 4"; DN 40 - 100

Pos. Item	Quantity	Description	included in spare parts (pos.)	Material	3"		DN80		DN100		4"		Reference no. Part no.		Reference no. Part no.	
					Reference no. Part no.	Reference no. Part no.	Reference no. Part no.	Reference no. Part no.	Reference no. Part no.	Reference no. Part no.	Reference no. Part no.	Reference no. Part no.				
1	1	Housing	D41 1-6	1.4404	000 16-61-562/47 H337188	000 16-61-537/47 H337183	000 16-61-637/47 H337184	000 16-61-662/47 H337189	000 16-61-666/47 H337194	000 16-61-662/47 H337199	000 16-61-662/47 H337189	000 16-61-666/47 H337199				
	1	Housing	D41 1-7	1.4404	000 16-61-572/47 H337178	000 16-61-547/47 H337173	000 16-61-647/47 H337174	000 16-61-672/47 H337179	000 16-61-641/47 H337194	000 16-62-672/47 H337032	000 16-61-672/47 H337179	000 16-61-666/47 H337199				
	1	Housing	D41 1-8	1.4404	000 16-61-566/47 H337198	000 16-61-541/47 H337193	000 16-61-641/47 H337194	000 16-61-666/47 H337199	000 16-61-641/47 H337194	000 16-62-672/47 H337032	000 16-61-666/47 H337199	000 16-61-666/47 H337199				
	1	Housing	D42	1.4404	000 16-62-572/47 H337031	000 16-62-547/47 H337026	000 16-62-647/47 H337027	000 16-62-672/47 H337032	000 16-62-647/47 H337027	000 16-62-672/47 H337032	000 16-62-672/47 H337032	000 16-62-672/47 H337032				
	1	Housing	D43	1.4404	000 16-63-572/47 H337041	000 16-63-547/47 H337036	000 16-63-647/47 H337037	000 16-63-672/47 H337042	000 16-63-647/47 H337037	000 16-63-672/47 H337042	000 16-63-672/47 H337042	000 16-63-672/47 H337042				
	1	Housing	D44	1.4404	000 16-64-572/47 H335275	000 16-64-547/47 H335278	000 16-64-647/47 H335279	000 16-64-672/47 H335280	000 16-64-547/47 H335279	000 16-64-672/47 H335280	000 16-64-672/47 H335280	000 16-64-672/47 H335280				
	2	Upper valve shaft		1.4404	000 16-25-566/00 H341267	000 16-25-541/00 H341266	000 16-25-541/00 H341266	000 16-25-641/00 H341268	000 16-25-541/00 H341266	000 16-25-641/00 H341268	000 16-25-641/00 H341268	000 16-25-641/00 H341268				
	3	Lower valve shaft		1.4404	000 16-25-564/42 H335392	000 16-25-539/42 H335393	000 16-25-539/42 H335393	000 16-25-639/42 H335394	000 16-25-539/42 H335393	000 16-25-639/42 H335394	000 16-25-639/42 H335394	000 16-25-639/42 H335394				
4	Shaft bearing		1.4404	000 16-28-300/12 H334381	000 16-28-300/12 H334381	000 16-28-301/12 H335713	000 16-28-301/12 H335713	000 16-28-301/12 H335713	000 16-28-301/12 H335713	000 16-28-301/12 H335713	000 16-28-301/12 H335713					
5	O-ring		EPDM	000 58-06-295/64 H77039	000 58-06-295/64 H77039	000 58-06-490/63 H77061	000 58-06-490/63 H77061	000 58-06-490/63 H77061	000 58-06-490/63 H77061	000 58-06-490/63 H77061	000 58-06-490/63 H77061					
6	Yoke		1.4301	000 16-40-200/12 H334383	000 16-40-200/12 H334383	000 16-40-209/12 H335994	000 16-40-209/12 H335994	000 16-40-209/12 H335994	000 16-40-209/12 H335994	000 16-40-209/12 H335994	000 16-40-209/12 H335994					
7	Guide rod		1.4404	000 16-25-562/00 H341296	000 16-25-537/00 H341295	000 16-25-537/00 H341295	000 16-25-637/00 H341297	000 16-25-537/00 H341295	000 16-25-637/00 H341297	000 16-25-637/00 H341297	000 16-25-637/00 H341297					
8	Retainer ring		1.4310	000 08-39-083/13 H14883	000 08-39-083/13 H14883	000 08-39-083/13 H14883	000 08-39-083/13 H14883	000 08-39-083/13 H14883	000 08-39-083/13 H14883	000 08-39-083/13 H14883	000 08-39-083/13 H14883					
9	1	Middle seal		EPDM	000 58-33-998/93 H327602	000 58-33-997/93 H327985	000 58-33-997/93 H327985	000 58-33-997/93 H327985	000 58-33-997/93 H327985	000 58-33-997/93 H327985	000 58-33-997/93 H327985					
	1	Middle seal		HNBR	000 58-33-998/33 H332652	000 58-33-997/33 H332649	000 58-33-997/33 H332649	000 58-33-997/33 H332649	000 58-33-997/33 H332649	000 58-33-997/33 H332649	000 58-33-997/33 H332649					
	1	Middle seal		FPM	000 58-33-998/71 H332653	000 58-33-997/71 H332648	000 58-33-997/71 H332648	000 58-33-997/71 H332648	000 58-33-997/71 H332648	000 58-33-997/71 H332648	000 58-33-997/71 H332648					

Information contained in this document is subject to change without notice and does not represent a commitment on the part of SPX FLOW, Inc.. No part of this document may be reproduced or transmitted in any form or by any means, electronic or mechanical, including photocopying and recording, for any purpose, without the express written permission of SPX FLOW, Inc..

Spare Parts List

Double seat mix proof valve D4 SL 1.5 "- 4"; DN 40 - 100

Date:	16.3.18	11.10.19	SPX FLOW			
Name:	C. Keil	Size-Si.				
Reviewed:						
Date:			Page	7	of	9
Name:			RN 501.047.01			
Reviewed:						

Pos. Item	Quantity	Description	included in spare parts (pos.)	Material	3"		DN80		4"		Reference no. Part no.
					Reference no. Part no.	Reference no. Part no.	Reference no. Part no.	Reference no. Part no.			
10	2	Seat seal		EPDM	000 58-33-132/93 H168192	000 58-33-133/93 H168153					
	2	Seat seal		HNBR	000 58-33-132/33 H171561	000 58-33-133/33 H171565					
	2	Seat seal		FPM	000 58-33-132/73 H171559	000 58-33-133/73 H171563					
11	2	Shaft seal		EPDM	000 58-33-400/93 H337476	000 58-33-405/93 H337668					
	2	Shaft seal		HNBR	000 58-33-400/33 H337478	000 58-33-405/33 H337670					
	2	Shaft seal		FPM	000 58-33-400/73 H337477	000 58-33-405/73 H337669					
12	3	Guide ring		Iglidur A500	000 58-01-610/99 H334863	000 58-01-612/99 H335702					
13	1	Guide band		Acoflon		000 08-39-380/99 H334865					
14	1	Quad ring	12,37x2,62	EPDM			000 58-01-049/63 H311646				
							000 65-50-087/15 H118903				
15	2	Hex. screw M10x1		A2		000 67-40-010/12 H335171					
16	2	Square key		A2		000 29-02-206/17 H335862					
17	1	Actuator	18, 19, 20	1.4301	000 29-02-190/17 H334394		000 58-06-113/83 H337897				
							000 16-28-330/93 H334376				
18	2	O-ring		NBR		000 58-01-600/73 H334379					
19	2	Actuator screw		Iglidur J350			000 58-06-113/83 H337897				
							000 16-28-330/93 H334376				
20	2	V-seal		NBR		000 58-01-600/73 H334379					

Information contained in this document is subject to change without notice and does not represent a commitment on the part of SPX FLOW, Inc. No part of this document may be reproduced or transmitted in any form or by any means, electronic or mechanical, including photocopying and recording, for any purpose, without the express written permission of SPX FLOW, Inc..

Spare Parts List

Double seat mix proof valve D4 SL 1.5" - 4"; DN 40 - 100

		Date:	16.3.18	11.10.19	21.08.20	SPX FLOW						
		Name:	C. Keil	Size-Si.	C. Keil							
		Reviewed:										
		Date:				Page	9 of 9					
		Name:				RN 501.047.01						
		Reviewed:										
Pos.	Item	Quantity	Description	included in spare parts (pos.)	Material	3"	DN80	DN100	4"	Reference no. Part no.	Reference no. Part no.	Reference no. Part no.
		1	CU43 D4 DC ø6mm		PA 6.6 GF30 black	Reference no. Part no.	Reference no. Part no.	Reference no. Part no.	Reference no. Part no.	Reference no. Part no.	Reference no. Part no.	Reference no. Part no.
		1	CU43 D4 M12 DC ø6mm		PA6.6 GF30 black	000 08-45-381/93 H336955	000 08-45-571/93 H341343					
		1	CU43 D4 AS-i Ext. Ø6mm		PA 6.6 GF30 black	000 08-45-383/93 H336957						
		1	CU43 D4 M12 AS-i Ext. ø6mm		PA6.6 GF30 black	000 08-45-387/93 H338897						
35		1	CU43 D4 AS-i Std. ø6mm		PA 6.6 GF30 black	000 08-45-385/93 H338152						
		1	CU43 D4 M12 AS-i Std. ø6mm		PA 6.6 GF30 black	000 08-45-391/93 H338899						
		1	CU43plus D4 V1 AS-i Ext. ø6mm		PA6.6 GF30 black	000 08-45-556/93 H338820						
		1	CU43plus D4 V1 M12 AS-i Ext. ø6mm		PA6.6 GF30 black	000 08-45-341/93 H338865						
36		1	Prox. switch holder D4 cmpl.		PA 6.6 GF30 black	000 16-33-050/93 H336751						
37		1	Operating cam D4 bottom		1.4523 / 444FR	000 08-60-461/99 H334386						
38		1	Operating cam D4 top		1.4523 / 444FR	000 08-60-460/99 H334387						
39		4	Hex. screw M8x40		A2-70	000 65-01-086/15 H336675						
Pos. 9, 10, 11, 12, 14 available as complete seal kits only												
		1	Seal kit		EPDM	000 58-38-005/01 H337884				000 58-38-006/01 H337887		
		1	Seal kit		FPM	000 58-38-005/00 H337886				000 58-38-006/00 H337889		
		1	Seal kit		HNBR	000 58-38-005/06 H337885				000 58-38-006/06 H337888		

Information contained in this document is subject to change without notice and does not represent a commitment on the part of SPX FLOW, Inc.. No part of this document may be reproduced or transmitted in any form or by any means, electronic or mechanical, including photocopying and recording, for any purpose, without the express written permission of SPX FLOW, Inc..

Spare Parts list

**Double seat mix proof valve
D4 SL - 125-150-6"**

SPX FLOW

Date: 11.10.19
Name: Sze-Si.
Reviewed:

Page 1 of 5

RN 501.047.03

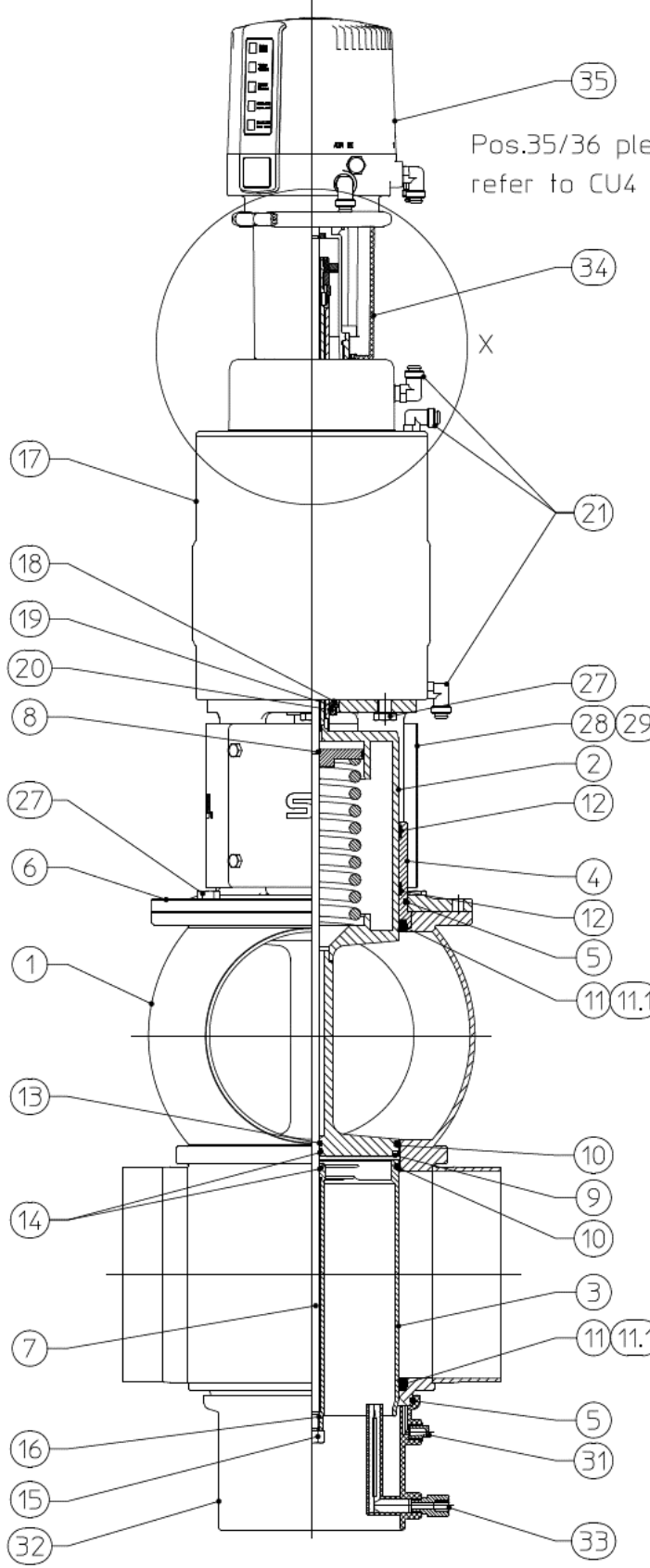

Pos.35/36 please refer to CU4 manual

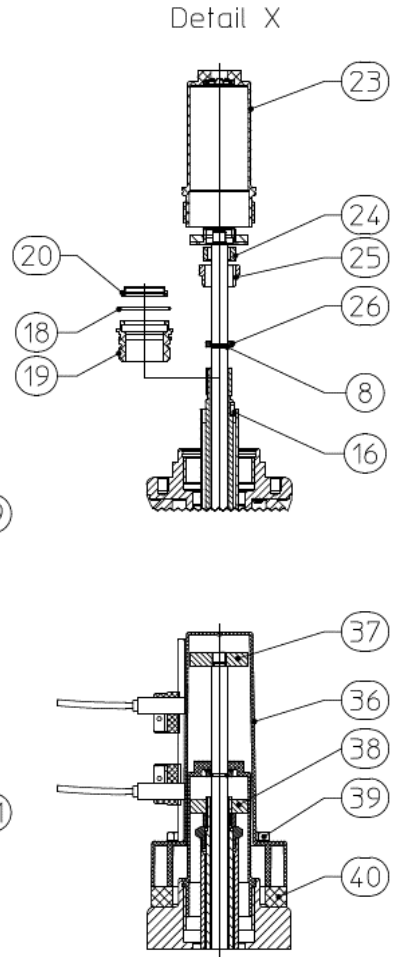

Information contained in this document is subject to change without notice and does not represent a commitment on the part of SPX FLOW, Inc.. No part of this document may be reproduced or transmitted in any form or by any means, electronic or mechanical, including photocopying and recording, for any purpose, without the express written permission of SPX FLOW, Inc..

Spare Parts list

**Double seat mix proof valve
D4 SL - 125-150-6"**

Date: 11.10.19										
Name: Size-Si.										
Reviewed:										
Date:										
Name:										
Reviewed:										
Page 2 of 5										
RN 501.047.03										
Pos.	Qty.	Description	Material	DN125 Reference no. Part no.	DN150 Reference no. Part no.	6" Reference no. Part no.				SPX FLOW
	1	Housing D41 / 1-6	1.4404	000 16-61-687/47 H340122	000 16-61-737/47 H340135	000 16-61-762/47 H340141				
	1	Housing D41 / 1-7	1.4404	000 16-61-697/47 H340123	000 16-61-747/47 H340136	000 16-61-772/47 H340142				
	1	Housing D41 / 1-8	1.4404	000 16-61-691/47 H340124	000 16-61-741/47 H340137	000 16-61-766/47 H340143				
1	1	Housing D42	1.4404	000 16-62-697/47 H340121	000 16-62-747/47 H340134	000 16-62-772/47 H340140				
	1	Housing D43	1.4404	000 16-63-697/47 H340120	000 16-63-747/47 H340133	000 16-63-772/47 H340139				
	1	Housing D44	1.4404	000 16-64-697/47 H340119	000 16-64-747/47 H340132	000 16-64-772/47 H340138				
2	1	Upper valve shaft	1.4404	000 16-25-694/00 H341269	000 16-25-694/00 H341270					
3	1	Lower valve shaft	1.4404	000 16-25-689/42 H340230	000 16-25-520/42 H340311					
4	1	Shaft bearing	1.4404	000 16-28-302/12 H340243	000 16-28-303/12 H340322					
5	2	O-ring	EPDM	000 58-06-555/63 H77074	000 58-06-655/63 H77081					
6	1	Yoke	1.4301	000 16-40-202/12 H340244	000 16-40-204/12 H340323					
7	1	Guide rod	1.4404	000 16-25-687/00 H341298	000 16-25-545/00 H341299					
8	2	Retainer ring	1.4310	08-39-083/13 H14883						
	1	Middle seal	EPDM	000 58-33-996/93 H340247	000 58-33-995/93 H340325					
9	1	Middle seal	HNBR	000 58-33-996/33 H340248	000 58-33-995/33 H340326					
	1	Middle seal	FPM	000 58-33-996/73 H340294	000 58-33-995/73 H340327					

Information contained in this document is subject to change without notice and does not represent a commitment on the part of SPX FLOW, Inc.. No part of this document may be reproduced or transmitted in any form or by any means, electronic or mechanical, including photocopying and recording, for any purpose, without the express written permission of SPX FLOW, Inc..

Spare Parts list

**Double seat mix proof valve
D4 SL - 125-150-6"**

		Date:	11.10.19												
		Name:	Size-Si.												
		Reviewed:													
		Date:													
		Name:													
		Reviewed:													
												Page	3	of	5
												RN 501.047.03			
pos.	item	Quantity	Description	included in spare parts (pos.)	Material	125 Reference no. Part no.	150 Reference no. Part no.	6" Reference no. Part no.							
		2	Seat seal		EPDM	000 58-33-135/93 H173940	000 58-33-134/93 H173739								
10		2	Seat seal		HNBR	000 58-33-135/33 H173939	000 58-33-134/33 H173738								
		2	Seat seal		FPM	000 58-33-135/73 H340246	000 58-33-134/73 H338070								
		2	Shaft seal		EPDM	000 58-33-693/93 H77611	000 58-33-743/93 H77628								
11		2	Shaft seal		HNBR	000 58-33-693/33 H170178	000 58-33-743/33 H170177								
		2	Shaft seal		FPM	000 58-33-693/73 H77610	000 58-33-743/73 H77627								
11.1		2	PTFE Shaft seal		PTFE	000 58-33-156/23 H340295	000 58-33-157/23 H340328								
12		2	Guide ring		Igildur A500	000 58-01-614/99 H340198	000 58-01-613/99 H340182								
13		1	Guide band		Acoflon	000 08-39-380/99 H334865									
14		2	Quad ring 12,37x 2,62		EPDM	000 58-01-049/63 H311646									
15		2	Hex. Screw M10x1		A2	000 65-50-087/15 H118903									
16		2	Square key DIN6885 - A - 3x3x10		A2	000 29-02-190/17 H335171									
17		1	Actuator	18, 19, 20	1.4301	000 29-02-208/17 H340197	000 29-02-207/17 H340181								
18		2	O-ring 30 x 2,5		NBR	000 58-06-113/83 H337897									
19		2	Actuator screw		Igildur J350	000 16-28-330/93 H334376									
20		2	V-seal		NBR	000 58-01-600/73 H334379									

Information contained in this document is subject to change without notice and does not represent a commitment on the part of SPX FLOW, Inc.. No part of this document may be reproduced or transmitted in any form or by any means, electronic or mechanical, including photocopying and recording, for any purpose, without the express written permission of SPX FLOW, Inc..

Spare Parts list

**Double seat mix proof valve
D4 SL - 125-150-6"**

Date:		11.10.19		10.06.20		SPX FLOW	
Name:		Sze-Si.		C.Keil			
Reviewed:							
Date:						Page 4 of 5	
Name:						RN 501.047.03	
Reviewed:							
pos. item	Quantity	Description	included in spare parts (pos.)	Material	Reference no. Part no.	Reference no. Part no.	6"
21	3	W-union G1/8" Ø6mm		hard nickel-plated	000 08-60-750/93 H208825		
22							
23	1	Stop screw		Grivory	000 16-28-340/39 H334382		
24	1	Lock washer D4		1.4301	000 67-03-030/12 H335172		
25	1	Safety nut D3		1.4301	000 65-50-137/15 H147640		
26	1	Thrust ring		1.4057	000 08-48-106/12 H123151		
27	8	Hex. screw M10 x 20		A2	000 65-01-134/13 H340472		
28	1	Yoke cover D4	29	1.4301	000 16-40-226/00 H341313	000 16-40-227/00 H341314	
29	4	Savetix head screw M6 x 8 washer M6 as set		1.4301	000 65-06-011/12 H340632		
30							
31	1	Venting plug G-1/8"		PE-Hard	000 08-74-014/93 H16507		
32	1	Spray connection DE3		PP	000 09-40-117/93 H178450	000 09-40-118/93 H200320	
33	1	G-union 10/8-G1/4" with supp. Sleeve cpl.		1.4571	000 16-38-200/42 H329696		
34	1	CU4 D4 adapter cmpl.		PA6.6 GF30 black	000 08-46-646/93 H337098		
	1	CU4plus D4 V1 adapter cmpl.		PA6.6 GF30 black	000 08-46-666/93 H336441		

Information contained in this document is subject to change without notice and does not represent a commitment on the part of SPX FLOW, Inc.. No part of this document may be reproduced or transmitted in any form or by any means, electronic or mechanical, including photocopying and recording, for any purpose, without the express written permission of SPX FLOW, Inc..

Spare Parts list

Double seat mix proof valve D4 SL - 125-150-6"

SPX FLOW

pos. item		Description		included in spare parts (pos.)		Material		125		150		6"		Reference no. Part no.		
								Reference no. Part no.	Reference no. Part no.	Reference no. Part no.	Reference no. Part no.					
1	CU43 D4 DC ø6mm					PA6.6 GF30 black		000 08-45-381/93 H336955								
1	CU43 D4 M12 DC ø6mm					PA6.6 GF30 black		000 08-45-571/93 H341343								
1	CU43 D4 AS-i Ext. ø6mm					PA6.6 GF30 black		000 08-45-383/93 H336957								
1	CU43 D4 M12 AS-i Ext. ø6mm					PA6.6 GF30 black		000 08-45-387/93 H338897								
1	CU43plus D4 V1 AS-i Ext. ø6mm					PA6.6 GF30 black		000 08-45-556/93 H338820								
1	CU43plus D4 V1 M12 AS-i Ext. ø6mm					PA6.6 GF30 black		000 08-45-341/93 H338865								
1	Prox. switch holder D4 compl.					PA6.6 GF30 black		000 16-33-050/93 H336751								
1	Operating cam D4 bottom					1.4523 / 444FR		000 08-60-461/99 H334386								
1	Operating cam D4 top					1.4523 / 444FR		000 08-60-460/99 H334387								
4	Hex. Screw					A2-70		000 65-01-086/15 H336675		000 65-01-087/15 H340751						
1	Spacer					PA6.6 GF30 black		-		000 08-20-107/93 H340179						
Pos. 9, 10, 11, 12, 13, 15 available as complete seal kits only																
1	Seal kit					EPDM		000 58-38-007/01 H340575		000 58-38-008/01 H340578						
1	Seal kit					FPM		000 58-38-007/00 H340577		000 58-38-008/00 H340580						
1	Seal kit					HNBR		000 58-38-007/06 H340576		000 58-38-008/06 H340579						

D4 / D4 SL

DOUBLE SEAT MIX PROOF VALVES

SPXFLOW

SPX FLOW

Design Center

Gottlieb-Daimler-Straße 13
D-59439 Holzwickede, Germany
P: (+49) (0) 2301-9186-0
F: (+49) (0) 2301-9186-300

SPX FLOW, Inc.

Production

611 Sugar Creek Road
Delavan, WI 53115, USA
P: (+1) 262 728 1900 or (800) 252 5200
F: (+1) 262 728 4904 or (800) 252 5012
E: wcb@spxflow.com

SPX FLOW reserves the right to incorporate the latest design and material changes without notice or obligation.

Design features, materials of construction and dimensional data, as described in this manual, are provided for your information only and should not be relied upon unless confirmed in writing. Please contact your local sales representative for product availability in your region. For more information visit www.spxflow.com.

ISSUED 09/2020 - Original manual
COPYRIGHT ©2020 SPX FLOW, Inc.